

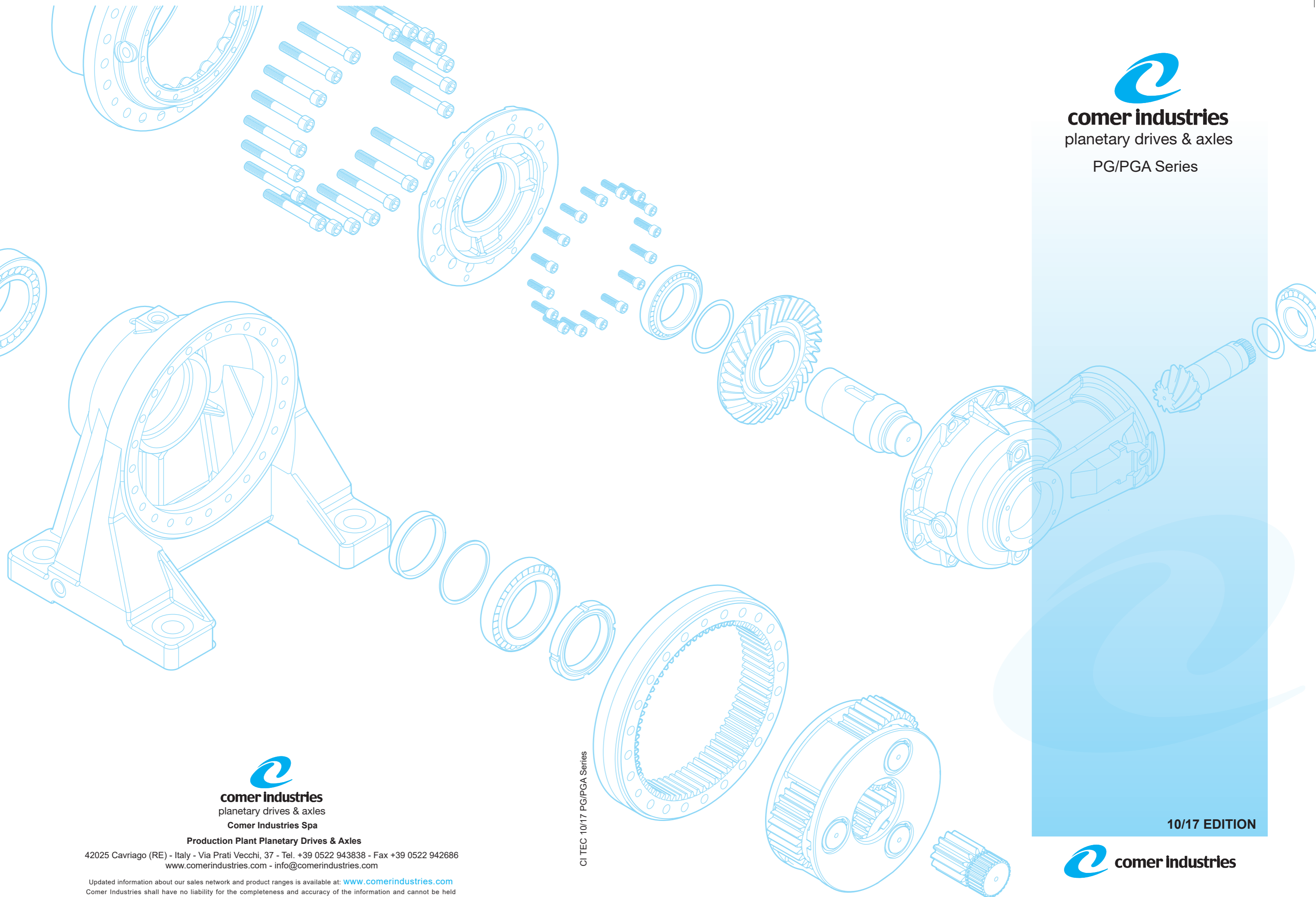

comer industries
planetary drives & axles

PG/PGA Series



comer industries
planetary drives & axles
Comer Industries Spa

Production Plant Planetary Drives & Axles

42025 Cavriago (RE) - Italy - Via Prati Vecchi, 37 - Tel. +39 0522 943838 - Fax +39 0522 942686
www.comerindustries.com - info@comerindustries.com

Updated information about our sales network and product ranges is available at: www.comerindustries.com
Comer Industries shall have no liability for the completeness and accuracy of the information and cannot be held liable for any third-party claims or losses of any damages. The information represented in this catalogue can be revised at any time without notice.

CI TEC 10/17 PG/PGA Series

10/17 EDITION



comer industries

IT

EN

DE

FR

ES

PT

Certificazione ATEX	ATEX Certification					A-3
L'azienda	The company	Das unternehmen	La société	La empresa	A empresa	A-4
Il prodotto	The product	Das produkt	Le produit	El producto	O produto	A-6
Le applicazioni	The applications	Die einsatzbereiche	Les applications	Las aplicaciones	As aplicações	A-8
Caratteristiche tecniche	Technical characteristics	Technische eigenschaften	Caractéristiques techniques	Características técnicas	Características técnicas	A-10
Installazione manutenzione	Installation maintenance	Einbau-wartung	Installation entretien	Instalación mantenimiento	Instalação manutenção	A-38
Lubrificazione	Lubrication	Schmierung	Lubrification	Lubricación	Lubrificação	A-44
Layout	Layout	Layout	Layout	Layout	Layout	A-62
Designazione prodotto	Product identification	Produktbeschreibung	Designation produit	Designación producto	Designação do produto	A-64
Simbologia	Legend	Legende	Symboles	Símbolos	Símbolos	A-66
Schede tecniche	Technical sheets	Tecnische Tenblätter	Fiches techniques	Fichas tecnica	Fichas tecnica	

INTR.

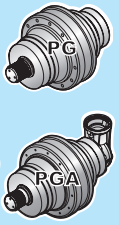
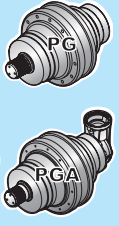
		i	Mc (n ₂ ,h 20.000) [kNm]			
	B	(3.56 ÷ 8360.53)	(0.45 ÷ 99.00)	B-1		
	100	3.56 ÷ 3422.25	0.45 ÷ 1.10	B-4		
	160	3.56 ÷ 3422.25	1.00 ÷ 1.70	B-12		
	250	3.78 ÷ 2369.25	1.73 ÷ 3.52	B-20		
	500	3.78 ÷ 1735.07	2.61 ÷ 5.11	B-28		
	700	3.67 ÷ 2722.78	3.85 ÷ 7.02	B-36		
	1000	3.56 ÷ 2229.71	4.41 ÷ 12.21	B-44		
	1600	3.56 ÷ 2229.71	9.13 ÷ 18.02	B-52		
	1800	13.04 ÷ 1561.86	12.01 ÷ 18.02	B-60		
	2500	4.00 ÷ 2277.71	16.91 ÷ 30.76	B-68		
	3000	14.22 ÷ 1425.06	23.51 ÷ 30.76	B-76		
	3500	4.00 ÷ 1289.65	16.65 ÷ 37.50	B-84		
	5000	3.95 ÷ 1981.97	20.64 ÷ 60.80	B-92		
	6500	3.83 ÷ 1005.54	49.57 ÷ 69.31	B-100		
9000	4.04 ÷ 8360.53	59.80 ÷ 99.00	B-108			
	C	(3.43 ÷ 8938.38)	(55.60 ÷ 858.10)	C-1		
	12000	4.09 ÷ 5665.81	55.60 ÷ 163.40	C-2		
	16000	3.83 ÷ 8729.66	65.60 ÷ 212.50	C-10		
	21000	3.68 ÷ 8127.84	71.80 ÷ 238.20	C-18		
	26000	3.68 ÷ 8018.87	155.30 ÷ 288.70	C-26		
	31000	3.43 ÷ 8522.08	128.40 ÷ 364.40	C-34		
	40000	3.43 ÷ 8938.38	257.00 ÷ 452.70	C-42		
	45000	3.83 ÷ 4952.48	305.80 ÷ 567.40	C-50		
	53000	3.84 ÷ 7890.76	386.50 ÷ 727.20	C-58		
	61000	3.84 ÷ 3175.35	401.00 ÷ 858.10	C-62		
Accessori d'entrata	Input fittings	Antriebsba uteile	Accessoires d'entree	Accesorios de entrada	Acessórios de entrada	D1
Freni modulari	Modular brakes	Bremsemodule	Freins modulaires	Frenos modulares	Freios modulares	D2
Alberi entrata	Input shafts	Antriebswellen	Arbres d'entrée	Ejes de entrada	Eixos de entrada	D4
Entrate dirette	Direct inputs	Standardantrieb	Entrée directes	Entradas directas	Entradas diretas	D8
Predisposizioni motori idraulici	Hydraulic motor couplings	Anbauvorrichtung fuer hydraulikmotore	Adaptations pour moteurs hydraulique	Acoplamientos para motores hidráulicos	Predisposiões para motores hidráulicos	D16
Predisposizioni motori elettrici	Electric motor couplings	Anbauvorrichtung für elektromotore	Adaptations pour moteurs electriques	Acoplamientos para motores eléctricos	Predisposiões para motores elétricos	D19
Predisposizioni per riduttori a vite senza fine	Worm gearbox adaptors	Anschluss für schneckengetriebe	Adaptation pour reducteurs a vis sans fin	Acoplamientos para reductores de tornillo sin fin	Predisposiões para reductores de rosca sem fim	D20

Certificazioni ATEX II 2 GD c k T4 e ATEX II 3 GD k T4 per i riduttori serie PG/PGA di Planetary Drives

Comer Industries amplia la serie di riduttori PG/PGA di Planetary Drives con la gamma ATEX (da Atmosphères Explosibles), in conformità con la Direttiva 94/9/CE che regola le apparecchiature destinate all'impiego in zone a rischio di esplosione.

I riduttori serie PG/PGA ATEX sono idonei per applicazioni in aree con presenza di atmosfera potenzialmente esplosiva e con presenza di miscele gassose e/o polveri combustibili. La Direttiva europea 94/9/CE impone la certificazione ATEX a tutti i prodotti commercializzati nell'Unione stessa, indipendentemente dal luogo di produzione e dalle normative in esso in vigore, se installati in luoghi a rischio di esplosione, con l'eccezione di alcuni apparecchi.

I riduttori progettati da Comer Industries per applicazione in ambienti ATEX si distinguono per l'utilizzo di materiali idonei secondo le norme di riferimento ed impiegano parti speciali quali anelli tenuta olio esclusivamente in Viton®; anelli paraolio in Viton® con labbro parapolvere e tappi sfiato con valvola a molla; utilizzo di olio e grasso sintetici, presenza di rilevatori adesivi termosensibili, spessori limitati della verniciatura e predisposizione per collegamento di messa a terra.

I riduttori PG/PGA ATEX vengono sottoposti a prove specifiche secondo quanto previsto dalle norme e sono forniti completi di specifico Manuale Istruzioni e Dichiarazione di conformità secondo l'allegato VIII della Direttiva 94/9/CE.

I dati tecnici dei riduttori ATEX sono indicati sul catalogo generale dei Riduttori serie PG/PGA.

ATEX II 2 GD c k T4 and ATEX II 3 GD k T4 certification for Planetary Drives series PG/PGA

Comer Industries extends the PG/PGA Planetary Drives series with the ATEX range (from Atmosphères Explosibles) in accordance with Directive 94/9/EC regulating equipment intended for use in areas at risk of explosion.

Planetary Drives series PG/PGA are suitable for application in areas with potentially explosive atmospheres and in areas with presence of gas mixtures and / or combustible dusts. The European Directive ATEX (from French words: Atmosphères Explosibles, potentially explosive atmosphere) 94/9/EC requires certification for all products marketed in the EU, regardless of place of production and local regulations in force, when installed in areas at risk of explosion, with the exception of some equipment.

Comer Industries specifically designed drives for use in ATEX environments differ from normal series mainly for the use of suitable materials as requested by the EU standards such as oil seal ring in Viton®; Viton® shaft seals with dust protection; breather plugs with valve; use of synthetic oil and grease; presence of heat-sensitive adhesive detectors; reduced paint thickness; arrangement for grounding.

PG/PGA ATEX drives are subjected to specific tests in accordance with the a.m. norms and are provided with an instruction manual in Italian and English language, including a Declaration of Conformity, as requested by attachment VIII, Directive 94/9/EC.

Technical data are indicated on the general catalogue PG/PGA series.

Comer Industries è leader internazionale nella progettazione e produzione di sistemi avanzati di ingegneria e soluzioni di mecatronica per la trasmissione di potenza, destinati ai principali costruttori mondiali di macchine per l'agricoltura e l'industria.

Comer Industries is a global leader in the design and production of advanced engineering systems and mechatronic solutions for power transmission, supplied to major manufacturers of agricultural machinery, construction equipment and industrial machinery worldwide.

Comer Industries ist einer der führenden Entwickler und Hersteller von fortschrittlichen Maschinenbausystemen und Mechatronik Lösungen für Kraftübertragung und beliefert die größten Hersteller von Landwirtschafts- und Baumaschinen sowie Industrieanwendungen weltweit.

Comer Industries progetta, produce e commercializza riduttori epicicloidali modulari, riduttori ruota e riduttori per rotazione destinati all'impiego su macchine operatrici mobili e impianti fissi industriali, assali rigidi e sterzanti.

Comer Industries designs, manufactures and markets modular planetary drives, wheel drive gear units, planetary slewing drives for installation on mobile operating machinery and stationary industrial equipment, rigid and steering axles.

Comer Industries entwickelt und fertigt modulare Planetengetrieben, Raduntersetzungen und Rotationsuntersetzungen für den Einsatz in verfahrenen und feststehenden Industriemaschinen gewidmet, Starre Achsen und Schwenkachsen.

Le trasmissioni Planetary Drives sono altamente personalizzate e l'ampia conoscenza delle applicazioni industriali unite all'elevata capacità progettuale consentono di rispondere alle esigenze del cliente con l'innovazione continua, la qualità e l'offerta di un servizio completo.

The planetary drive transmissions are highly customised and, thanks to extensive knowledge of industrial applications combined with cutting-edge design expertise, Comer Industries meets all customer requirements through constant innovation, quality and comprehensive service.

Die Planetengetriebe werden kundenindividuell gefertigt und dank der großen Erfahrung bei den Industrieanwendungen sowie der optimalen Entwicklungskapazität kann den Kundenansprüchen mit kontinuierlicher Innovation und einem kompletten Service-Angebot entsprechen werden.



Comer Industries est le leader mondial dans la conception et la production de systèmes d'ingénierie de pointe et des solutions mécatroniques pour la transmission de puissance, fournis aux principaux fabricants pour les applications sur les machines agricoles, les engins de chantier, dans l'industrie à travers le monde.

Comer Industries s'occupe de la conception, de production et de la commercialisation de réducteurs épicycloïdaux modulaires, de réducteurs de roue et de réducteurs de rotations destinés à une utilisation sur des machines mobiles ou sur des installations fixes industrielles, ponts rigides, directionnels et moteurs.

Les transmissions Planetary Drives sont hautement personnalisables et la connaissance étendue des applications industrielles alliée à de hautes capacités de conception permettent de répondre aux exigences des clients à travers de constantes innovations, la qualité et l'offre d'un service complet.

Comer Industries es líder internacional en el proyecto y la producción de soluciones de mecatrónica para la transmisión de potencia, destinados a los constructores mundiales de máquinas para la agricultura, la industria, la construcción.

Comer Industries diseña, produce y comercializa reductores epicicloidales modulares, reductores de rueda y reductores para rotación destinados al empleo en máquinas móviles y en instalaciones industriales fijas, ejes rígidos y direccional.

Las transmisiones Planetary Drives son muy personalizadas y, gracias al gran conocimiento de las aplicaciones industriales junto con la elevada capacidad de diseño, Comer Industries puede satisfacer las exigencias del Cliente a través de la innovación continua, la calidad y brindando un servicio completo.

Comer Industries é líder internacional na concepção e produção de soluções de mecatrónica para a transmissão de potência, destinados aos principais construtores mundiais de máquinas para a agricultura, a indústria, a construção civil.

Comer Industries é a dedicada ao projeto, produção e comercialização de reductores planetários modulares, reductores de roda e reductores para rotação destinados ao emprego em máquinas operatrizes móveis e em equipamentos industriais fixos, eixos rígidos e direção.

As transmissões Planetary Drives são altamente personalizadas e o amplo conhecimento das aplicações industriais, aliado à elevada capacidade de projeto, permitem responder às exigências do cliente com a inovação contínua, a qualidade e a oferta de um serviço completo.



L'utilizzo del riduttore epicicloidale per la trasmissione di potenza è una risposta moderna alle esigenze di ingombri limitati, di semplicità costruttiva e di affidabilità per l'utilizzatore.

I riduttori epicicloidali PG/PGA sono costituiti da acciaio per il 60% e ghisa per il 35% circa e in percentuale minore da alluminio, rame, gomma e ottone. Tali percentuali variano a seconda delle configurazioni del prodotto.

La famiglia di riduttori epicicloidali PG è offerta al mercato in 23 grandezze di base, selezionate in funzione dei momenti torcenti che possono essere trasmessi all'albero di uscita, che vanno da 0.5 kNm fino a 95 kNm.

La modularità del prodotto Planetary Drives permette l'accoppiamento ai riduttori epicicloidali di coppie coniche, riduttori vite senza fine, freni idraulici, diversi tipi di alberi di ingresso, nonché di flange per l'accoppiamento diretto a motori idraulici o elettrici.

Un altro grande vantaggio derivante dalla modularità dei riduttori epicicloidali è la possibilità del montaggio in serie di stadi di differenti grandezze, in modo da ottenere una vastissima gamma di rapporti di riduzione.

La gamma di prodotti Planetary Drives offre rapporti di riduzione da 3.43:1 a 8.67:1 per i riduttori a singolo stadio fino a 8900:1 e oltre per i riduttori a 5 stadi di riduzione.

Le diverse opzioni di albero e flangiatura in uscita semplificano l'installazione del riduttore su applicazioni mobili e impianti fissi industriali.

La fornitura standard del prodotto non prevede la verniciatura a finire. Comer Industries raccomanda l'utilizzo di vernici a basso impatto ambientale.

The use of planetary gear units in the field of power transmission is the modern answer to the demand for compactness, constructive simplicity and product reliability.

PG/PGA planetary drives are made of 60% steel, about 35% cast iron and a lower percentage of aluminium, copper, rubber and brass. These percentages vary depending on the product configurations.

PG planetary gear units are divided into 23 basic groups depending on the different torques that are to be transmitted to the output shaft, which can vary from 0.5 to 95 kNm.

In fact, the Planetary Drives product modular construction permits the coupling of bevel gears, worm gears, hydraulic brakes and a variety of input shafts to the planetary units, as well as providing for a wide choice of coupling flanges for hydraulic or electric motors.

Another advantage of the planetary drives' modular construction is that various stages, in different sizes, can be mounted in series to offer a wide range of reduction ratios. Planetary Drive reduction ratios range from 3.43:1 to 8.67:1 on single-stage drives up to 8900:1 and more on 5-stage drives.

The wide selection of output shafts and flanges simplifies the reduction unit mounting operation on industrial machinery or plants.

Standard supply of the product does not include painting upon completion. Comer Industries recommends using eco-friendly paints.

Im Vergleich zum Stirnradgetriebe, bei dem nur ein Zahn die Kräfte überträgt, wird das Moment am Zentralrad des Planetengetriebes auf drei Zahneingriffe aufgeteilt. Diese Konstruktion führt zu kleinen Getriebeabmessungen, kompakter Bauweise und einem geringen Eigengewicht.

Die Planetengetriebe PG/PGA bestehen zu 60% aus Stahl, zu ca. 35% aus Gusseisen und aus geringeren Mengen Aluminium, Kupfer, Gummi und Messing. Diese prozentuellen Anteile variieren je nach Konfiguration des Produkts.

Die Planetengetriebe der Serie PG werden in 23 Grundgrößen mit Abtriebsdrehmomenten von 0.5 kNm bis zu 95 kNm hergestellt.

Die modulare Konstruktion der Planetary Drives-Produkte erlaubt die Kombination mit Kegelaradgetrieben, Schneckengetrieben, hydraulischen Bremsen, unterschiedlichen Ausführungen von Antriebswellen und Motorflanschen für hydraulische und elektrische Motore.

Ein weiterer Vorteil der modularen Bauweise der Getriebe besteht darin, dass viele Stufen in verschiedenen Größen so miteinander kombiniert werden können, dass eine große Bandbreite an Gesamtuntersetzungen angeboten werden kann. Die Untersetzungen reichen von 3.43:1 bis 8.67:1 bei einstufigen Getrieben bis hin zu 8900:1 oder mehr bei fünfstufigen Getrieben.

Die verfügbaren Formen hinsichtlich der Wellen und Flansche des Abtriebs erlauben den Einbau der Getriebe in diversen mobilen und stationären Applikationen.

Die Standardausführung des Produkts wird ohne Schlussanstrich geliefert. Comer Industries empfiehlt den Gebrauch von umweltfreundlichen Lacken.



L'utilisation du réducteur planétaire pour la transmission de puissance est une solution moderne répondant aux exigences de dimensions réduites, de simplicité dans la construction et de fiabilité pour l'utilisateur.

Les réducteurs épicycloïdaux PG/PGA sont réalisés à 60% en acier et à 35% environ en fonte, avec un pourcentage minime d'aluminium, de cuivre, de laiton et de caoutchouc. Ces pourcentages varient selon les différentes configurations du produit.

La famille de réducteurs planétaires PG se présente sur le marché avec 23 types de base, sélectionnés en fonction des couples transmissibles sur l'arbre de sortie qui vont de 0.5 à 95 kNm.

La construction modulaire du produit Planetary Drives permet d'accoupler les réducteurs planétaires avec des couples coniques, des vis sans fin, des freins hydrauliques ou bien avec divers types d'arbres d'entrée, ainsi qu'avec des brides pour la fixation directe sur moteurs hydrauliques ou électriques.

La possibilité de monter en série des étages de différents rapports permettant d'obtenir une très vaste gamme de rapports de réduction (de 3.43:1 à 8.67:1 pour les réducteurs mono-étagés et jusqu'à 8900:1 et plus pour les réducteurs à 5 étages de réduction) est un autre grand avantage résultant de la conception modulaire des réducteurs Planetary Drives.

La possibilité de disposer de plusieurs options en ce qui concerne l'arbre et le bridage côté sortie du réducteur simplifie le montage de ce dernier sur les machines ou sur les équipements industriels.

La fourniture standard du produit ne prévoit pas la peinture de finition. Comer Industries recommande l'utilisation de peintures à faible impact environnemental.

La utilización del reductor epicicloidal para la transmisión de potencia es una solución moderna ante las exigencias de espacios limitados, de sencillez constructiva y de confiabilidad para el utilizador.

Los reductores epicicloïdales PG/PGA están constituidos por un 60% de acero, aproximadamente, un 35% de fundición y, en menor porcentaje, por aluminio, cobre, caucho y latón. Estos porcentajes varían según las configuraciones del producto.

La familia de reductores epicicloïdales PG está compuesta por 23 grupos básicos, seleccionados en función de los momentos de torsión que se pueden transmitir al eje de salida, que van desde 0.5 kNm hasta 95 kNm.

La construcción modular del producto Planetary Drives permite acoplar a los reductores epicicloïdales de pares cónicos, reductores de tornillo sin fin, frenos hidráulicos, distintos tipos de ejes de entrada, así como bridas para el acoplamiento directo a motores hidráulicos o eléctricos.

Otra gran ventaja ofrecida por la construcción modular de los reductores epicicloïdales es la posibilidad del montaje en serie de etapas con diferente magnitud, para poder obtener una vasta gama de relaciones de reducción.

La gama de productos Planetary Drives ofrece relaciones de reducción de 3.43:1 a 8.67:1 para los reductores con una sola etapa hasta 8900:1 y más para los reductores con 5 etapas de reducción. Osullemus

Las distintas opciones de eje y de embridado en la salida simplifican la instalación del reductor en aplicaciones móviles y en instalaciones industriales fijas.

El suministro estándar del producto no prevé la pintura de terminación. Comer Industries recomienda usar pinturas de bajo impacto ambiental.

A utilização de redutores planetários para a transmissão de potência é uma resposta moderna às exigências de compactidade, simplicidade de construção e confiabilidade para o usuário final.

Os reductores planetários PG/PGA estão constituídos de 60% de aço, aproximadamente, 35% de ferro fundido e em menor percentagem, por alumínio, cobre, borracha e latão. Estes percentuais variam de acordo às configurações do produto.

A família de reductores planetários PG é oferecida ao mercado em 23 tamanhos básicos, selecionados em função dos momentos de torção que podem ser transmitidos ao eixo de saída, que vão de 0,5 kNm a 95 kNm.

A modularidade do produto Planetary Drives permite o acoplamento a reductores planetários de pares cónicos, reductores de rosca sem fim, freios hidráulicos, vários tipos de eixos de entrada, assim como a seleção de flanges para o acoplamento direto a motores hidráulicos ou elétricos.

Uma outra grande vantagem proporcionada pela modularidade dos reductores planetários é a possibilidade da montagem em série de estágios de diferentes tamanhos, permitindo a obtenção de uma gama extremamente ampla de relações de redução.

A gama de produtos Planetary Drives oferece relações de redução que vão de 3.43:1 a 8.67:1 para reductores de um estágio, até 8900:1 e acima para unidades com 5 estágios de redução.

As diferentes opções de eixos e flanges de saída simplificam a instalação do reductor em aplicações móveis e equipamentos industriais fixos.

O fornecimento padronizado do produto não prevê a pintura de acabamento. Comer Industries recomenda a utilização de pinturas de baixo impacto ambiental.



IT**LE APPLICAZIONI**

Dai primi impieghi limitati soprattutto alle macchine movimento terra, Comer Industries ha esteso ed evoluto le possibilità applicative nel settore industriale. Sempre più frequenti sono le applicazioni in impianti chimici, macchine utensili, macchine lavorazione marmo, sistemi di trasporto e sollevamento, impianti alimentari ed ecologici e macchine mobili in generale.

EN**THE APPLICATIONS**

From when the first applications were implemented, limited mainly to earth-moving machinery, Comer Industries has extended and fully developed other applications in the industrial sector. The range of applications has now been extended to a wide variety of mobile machinery, chemical plants, machine tools, marble processing machinery, transportation and hoisting systems, in addition to the food and ecology industries.

DE**DIE EINSATZBEREICHE**

Seit den ersten Anwendungen, die sich hauptsächlich auf Erdbewegungsmaschinen beschränkten, hat Comer Industries die Anwendungsmöglichkeiten in ständig erweitert. Immer öfter werden die Planetengetriebe auch in industriellen Anwendungen, wie Förder- und Hubsystemen, Krananlagen, im Schiffsbau, in der Offshore-Technik, Stahlverarbeitung, Anlagen der Chemie, im Bereich alternativer Energien, Umwelttechnik und der Nahrungsmitteltechnologie eingesetzt, um nur einige Schwerpunkte aufzuzeigen.

FR**LES APPLICATIONS**

Depuis les premières applications qui se limitaient principalement aux engins des travaux publics, Comer Industries a étendu et développé les possibilités d'emploi dans le domaine industriel.

Les applications sont maintenant de plus en plus fréquentes dans les complexes chimiques, alimentaires et écologiques ainsi que sur les machines outils, les machines pour le travail du marbre, les dispositifs de transport et de relevage et toutes les machines mobiles en général.

ES**LAS APLICACIONES**

A partir de las primeras utilizaciones, limitadas sobretudo a las máquinas para el movimiento de tierra, Comer Industries amplió y desarrolló las posibilidades de aplicación en el sector industrial. Son cada vez más frecuentes las aplicaciones en las instalaciones químicas, máquinas herramientas, máquinas para la elaboración del mármol, sistemas de transporte y elevación, instalaciones alimenticias y ecológicas y máquinas móviles en general.

PT**AS APLICAÇÕES**

A partir das primeiras aplicações limitadas principalmente às máquinas de terraplanagem, a Comer Industries estendeu e evoluiu as possibilidades de aplicação no setor industrial. São cada vez mais frequentes as aplicações em plantas químicas, máquinas operatrizes, máquinas de processamento de mármore, sistemas de transporte e elevação, equipamentos nos setores alimentar e ecológico e máquinas móveis em geral.



Applicazioni marine - comando eliche direzionali
 Marine applications - directional propellers control
 Schiffsbau - Drehwerk fuer Ruder- und Propellersteuerung
 Application marines - commande d'hélices
 Aplicaciones marinas - mando de hélices direccionales
 Aplicações marinhas - controle de hélices direcionais



Pompe per calcestruzzo
 Concrete pumps
 Betonpumpe
 Pompes à béton
 Bombas para hormigón
 Bombas para concreto



Autogru
 Off-road mobile cranes
 Autokraene
 Grues mobiles
 Camión grúa
 Caminhões-guindaste

Carri miscelatori orizzontali
 Horizontal feed mixers
 Horizontal-Futtermischwagen
 Chariots mélangeurs horizontaux
 Carros mezcladores horizontales
 Carros misturadores horizontais



Gru e sistemi di sollevamento
 Cranes and hoisting systems
 Kraene und Hubsysteme
 Grues et systèmes de leverage
 Grúas y sistemas de elevación
 Guindastes e sistemas de elevação



Generatori eolici
 Wind power generators
 Windkraftanlagen
 Eoliennes
 Generadores eólicos
 Geradores eólicos





Carri miscelatori verticali
Vertical feed mixers
Vertikal-Futtermischwagen
Chariots mélangeurs verticaux
Carros mezcladores verticales
Carros misturadores verticais



Gru gommate e cingolate
Wheeled and tracked cranes
Mobilkraene
Grues sur pneumatiques et sur chenilles
Grúas sobre neumáticos y de orugas
Guindastes sobre rodas e sobre esteiras



Trattamento acque
Water treatment
Wasseraufbereitung
Traitement des eaux
Tratamiento de aguas
Tratamento de água

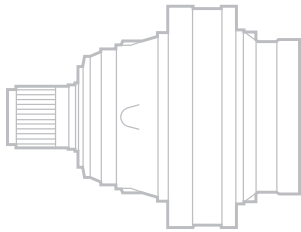

Gru per edilizia
Tower cranes
Turmkraene
Grues de le secteur du bâtiment
Grúas para la construcción
Guindastes torres

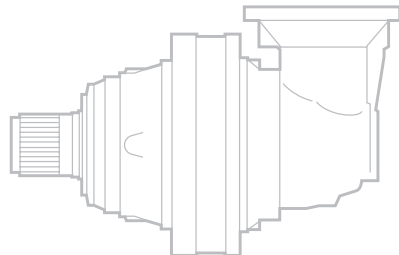

Impianti fissi industriali
Stationaere Industrieanlagen
Installations industrielles fixes
Instalaciones industriales fijas
Equipamentos industriais fixos



Impianti trasformazione ferro/acciaio
Steel/iron processing equipments
Anlagen der Stahlzeugung
Installations de transformation fer/acier
Instalaciones para transformar hierro/acero
Equipamentos de transformação do ferro/aço



Giostre
Amusement park rides
Vergnuegungseinrichtungen
Manèges
Carruseles
Brinquedos de parques de diversão



Macchine enologiche, presse per uva
Wine-making machines, grape presses
Weinherstellung - Pressen
Machines viticoles, pressoirs à raisin
Máquinas enológicas, prensas para uva
Máquinas enológicas, prensas para uva





CARATTERISTICHE TECNICHE

La conoscenza e l'esatta interpretazione dei dati riportati sul presente catalogo sono condizione indispensabile per la scelta e l'impiego corretto dei prodotti presentati.

È importante quindi definire alcuni parametri caratteristici:

RAPPORTO DI TRASMISSIONE i

È il valore effettivo del rapporto tra la velocità di entrata n_1 e la velocità di uscita n_2 .
Viene indicato per ogni tipo di riduttore nella relativa scheda tecnica.

VELOCITÀ MASSIMA IN ENTRATA

n_{1max} [min^{-1}]

Rappresenta il valore massimo accettabile per ogni grandezza di riduttore, in condizioni di funzionamento intermittente. Per applicazioni in servizio continuo o per velocità superiori a quelle indicate, il Servizio Tecnico Commerciale Comer Industries è a disposizione per ulteriori chiarimenti.

I valori della velocità massima in entrata per ogni tipo di riduttore sono illustrati nelle singole schede tecniche.

RENDIMENTO

Nella trasmissione epicicloidale, il rendimento è generalmente elevato, mediamente 0.97- 0.98 per ogni stadio di riduzione. Questo dato indicativo si riduce nel caso di funzionamenti a velocità elevate o nel caso di riduttori in versione angolare.

COPPIA CONTINUA

M_c [kNm]

È quella coppia per cui il valore delle sollecitazioni sugli ingranaggi è pari al valore limite secondo le norme internazionali ISO 6336.

Questo valore convenzionale corrisponde ad una durata di vita teorica illimitata degli ingranaggi, tenendo conto sia della sollecitazione a flessione che della resistenza superficiale del dente (pressione di Hertz).

TECHNICAL INFORMATION

To properly select and implement our products, users must have complete knowledge of and correctly interpret the information provided in this catalogue.

Thus, it's important to define some distinctive parameters, such as:

REDUCTION RATIO i

This is the ratio between input speed n_1 and output speed n_2 .
It is provided for each drive shown on the relative technical sheet.

MAXIMUM INPUT SPEED

n_{1max} [min^{-1}]

This is the maximum allowable speed for each size of drive under intermittent work conditions. For more information about continuous duty or higher speeds, please contact the Comer Industries Technical-Commercial Service Department.
Maximum speed values for each type of planetary drive are illustrated on the single technical sheets.

EFFICIENCY

Efficiency is usually high in planetary transmissions: average values range between 0.97 and 0.98 for each reduction stage. This approximate value decreases under high-speed conditions or in applications with bevel gears.

CONTINUOUS TORQUE

M_c [kNm]

Continuous torque is the maximum value of the stress on the gears according to international standard ISO 6336.

This conventional value corresponds to the unlimited theoretical duration of the gears, taking into account both the bending stress and the surface strength of the tooth (Hertz pressure).

TECHNISCHE EIGENSCHAFTEN

Die Kenntnis der Anforderung, sowie die korrekte Umsetzung der im Katalog gelieferten Daten sind Voraussetzung für die gezielte Auswahl und somit den erfolgreichen Einsatz des entsprechenden Produktes.

Es ist deshalb wichtig, die folgenden Bestimmungsfaktoren festzulegen:

ÜBERSETZUNG i

Es handelt sich um den Quotienten aus Antriebsdrehzahl n_1 und Abtriebsdrehzahl n_2 .
Sie wird für jedes Getriebemodell im jeweiligen technischen Datenblatt angegeben.

MAXIMAL ZULÄSSIGE ANTRIEBSDREHZAHL

n_{1max} [min^{-1}]

Ist die zulässige Höchstgeschwindigkeit für jedes Planetengetriebe im intermittierenden Betrieb. Im Dauerbetrieb mit Antriebsdrehzahlen, die die angegebenen Werte überschreiten, halten Sie bitte Rücksprache mit dem Kundenservice (Sales) von Comer Industries.

Die Werte der zulässigen Eingangsdrehzahl sind für jedes Getriebemodell im technischen Datenblatt angegeben.

WIRKUNGSRAD

Der Wirkungsgrad des Planetengetriebes liegt pro Planetenstufe bei 98%; d.h. bei einem dreistufigem Getriebe $\eta_{gesamt} = 0,98 \times 0,98 \times 0,98 = 94\%$. Dieser Anhaltswert nimmt beim Betrieb mit hohen Geschwindigkeiten sowie bei Getrieben in der Winkelausführung ab

DAUERDREHMOMENT

M_c [kNm]

Dieser allgemein festgelegte Wert entspricht einer theoretisch unbegrenzten Lebensdauer der Zahnräder, wobei sowohl die Biegespannung als auch die zulässige Hertz'sche Pressung auf die Zahnflankenoberfläche berücksichtigt werden.

Es handelt sich um das Limit der Beanspruchung an die Verzahnung gemäss der Norm ISO 6336

CARACTERISTIQUES TECHNIQUES

La connaissance et la bonne interprétation des données contenues dans le présent catalogue sont deux conditions indispensables qui permettent de choisir et d'utiliser correctement les produits présentés.

Il est par conséquent important de définir un certain nombre de paramètres spécifiques:

RAPPORT DE TRANSMISSION i

Il s'agit de la valeur effective du rapport entre la vitesse d'entrée n_1 et la vitesse de sortie n_2 .

Elle est indiquée sur la fiche technique de chaque type de réducteurs.

VITESSE MAXIMALE D'ENTREE

n_{1max} [min^{-1}]

Ce paramètre représente la vitesse maximale admise pour chaque taille de réducteur, en condition de fonctionnement intermittent. Pour des applications en service continu ou bien pour des vitesses supérieures à celles indiquées, le Service Technico-Commercial Comer Industries est à votre disposition pour toute information supplémentaire.

Les valeurs de vitesse maximale en entrée sont indiquées sur la fiche technique de chaque type de réducteur.

RENDEMENT

Sur les transmissions épicycloïdales, le rendement est généralement élevé, 0.97-0.98 en moyenne pour chaque étage de réduction. Cette donnée indicative peut être inférieure dans le cas d'un fonctionnement à haute vitesse ou dans le cas de réducteurs en version angulaire.

COUPLE CONTINU

M_c [kNm]

Il s'agit du couple auquel la valeur des sollicitations sur les engrenages est égale à la valeur limite selon les normes internationales ISO 6336.

Cette valeur conventionnelle correspond à une durée de vie théorique illimitée des engrenages, en tenant compte aussi bien de la contrainte de flexion que de la résistance de la surface de la dent (pression de Hertz).

CARACTERÍSTICAS TÉCNICAS

El conocimiento y la correcta interpretación de los datos indicados en este catálogo son una condición indispensable para efectuar la mejor elección y utilización de los productos presentados.

Por tanto es importante definir algunos parámetros característicos:

RELACIÓN DE TRANSMISIÓN i

Es el valor efectivo de la relación entre la velocidad de entrada n_1 y la velocidad de salida n_2 .

El valor para cada tipo de reductor se indica en la respectiva ficha técnica.

VELOCIDAD MÁXIMA DE ENTRADA

n_{1max} [min^{-1}]

Representa el valor máximo aceptable para cada dimensión de reductor, con funcionamiento intermitente. Para aplicaciones con servicio continuo o para velocidades superiores a aquellas indicadas, se aconseja ponerse en contacto con el Servicio Técnico-Comercial de Comer Industries.

Los valores de la velocidad máxima de entrada para cada tipo de reductor se indican en las respectivas fichas técnicas.

RENDIMIENTO

En la transmisión epicicloidial, el rendimiento es generalmente elevado, entre 0.97-0.98 para cada etapa de reducción. Este dato indicativo se reduce para el funcionamiento con elevadas velocidades o para aplicaciones con reductores cónicos.

MOMENTO DE TORSIÓN CONTINUO

M_c [kNm]

Es el valor del momento para el cual el valor de las sollicitaciones en los engranajes es igual al valor límite según las normas internacionales ISO 6336.

Este valor convencional corresponde a un tiempo de vida teórico ilimitado de los engranajes, teniendo en cuenta la sollicitación bajo flexión y la resistencia superficial del diente (presión de Hertz).

CARACTERÍSTICAS TÉCNICAS

O conhecimento e a interpretação exata dos dados fornecidos neste catálogo são uma condição indispensável para a seleção e o emprego correto dos produtos apresentados

É assim extremamente importante definir alguns parâmetros característicos:

RELAÇÃO DE TRANSMISSÃO i

É o valor efetivo da relação entre a velocidade de entrada n_1 e a velocidade de saída n_2 .

É indicado para cada tipo de reductor na respectiva ficha técnica.

VELOCIDADE MÁXIMA DE ENTRADA

n_{1max} [min^{-1}]

Representa o valor máximo aceitável para cada tamanho de reductor, em condições de funcionamento intermitente. Para aplicações em serviço contínuo ou para velocidades maiores do que as indicadas, o Serviço Técnico Comercial da Comer Industries está à disposição dos clientes para fornecer mais esclarecimentos.

Os valores da velocidade máxima de entrada para cada tipo de reductor são indicados nas respectivas fichas técnicas.

RENDIMENTO

Na transmissão epicicloidial, o rendimento é geralmente elevado, em média 0.97-0.98 para cada estágio de redução. Este dado indicativo diminui no caso de funcionamentos com velocidade elevada ou no caso de reductores na versão angular.

TORQUE CONTÍNUO

M_c [kNm]

Representa o torque para o qual o valor das sollicitações nas engrenagens corresponde ao valor limite segundo as normas internacionais ISO 6336.

Este valor convencional corresponde a uma vida útil teórica ilimitada das engrenagens, considerando tanto a sollicitação à flexão, como a resistência superficial do dente (pressão de Hertz).



CARATTERISTICHE TECNICHE



TECHNICAL INFORMATION



TECHNISCHE EIGENSCHAFTEN

Ai fini della scelta del riduttore questo valore va posto in riferimento alla COSTANTE DI DURATA n_xh espressa nel Diagramma 1 dove:

n = velocità in uscita (min^{-1})
 h = durata di funzionamento (ore).

Per semplicità di consultazione, nella scheda tecnica di prodotto sono riportati i valori di M_c corrispondenti ad un valore n_xh prefissato.

For the purpose of selecting a drive, this value must be considered in relation to the DURATION CONSTANT n_xh , as shown in Curve 1 where:

n = output speed (min^{-1})
 h = working time (hours)

To make consultation easier, the M_c values corresponding to a fixed n_xh value are shown on the product technical sheets.

Um eine korrekte Auswahl des Getriebes zu treffen, muß dieser Wert in Bezug zur LEBENSDAUER- KONSTANTE n_xh gesetzt werden (Diagramm 1).

n = Drehzahl an der Ausgangswelle (min^{-1})
 h = Betriebsdauer (Stunden)

Zum einfacheren Nachschlagen sind in dem Datenblatt die einem vorgegebenen Wert von n_xh entsprechenden M_c -Werte angegeben.

COPPIA MASSIMA

M_{\max} [kNm]

È il valore massimo di coppia che il riduttore può trasmettere per breve tempo senza che si verifichino danneggiamenti ai suoi componenti interni ed alla sua struttura. Tale valore deve essere considerato come una coppia massima dovuta a picchi o spunti di avviamento e mai come coppia di lavoro; il valore M_{\max} deve inoltre essere opportunamente valutato in quegli azionamenti che comportano un elevato numero di avviamenti o inversioni.

Il valore M_{\max} è indicato nelle schede tecniche di prodotto.

MAXIMUM TORQUE

M_{\max} [kNm]

This is the maximum output torque that the drive can transmit over a brief time interval without damaging its internal components and structure. This value must be considered as the maximum output torque owing to working or start-up peaks and never as the continuous working torque. M_{\max} must also be carefully evaluated in those applications with a high number of start-ups or reversals.

The M_{\max} value is shown on the single product technical cards.

MAXIMALES DREHMOMENT

M_{\max} [kNm]

Es handelt sich um den maximal zulässigen Wert des Drehmoments, den das Getriebe kurzzeitig übertragen kann, ohne daß Schäden auftreten. Dieser Wert ist als maximales Drehmoment bei kurzzeitigen Spitzenbelastungen zu betrachten und niemals als Drehmoment bei Dauerbetrieb; er muß außerdem jeweils entsprechend dem Lastkollektiv gewertet werden.

Der Wert M_{\max} wird in den technischen Datenblättern des entsprechenden Getriebetyps ausgewiesen.

TEMPERATURA DI FUNZIONAMENTO

Le temperature dell'olio a cui i riduttori possono funzionare sono quelle comprese tra -20°C e $+90^\circ\text{C}$. Temperature al di fuori di questa fascia possono essere accettate se si prevedono particolari accorgimenti relativi ai tipi di lubrificante e di guarnizioni utilizzati. Tali accorgimenti possono essere decisi caso per caso, d'accordo con il Servizio Tecnico-Commerciale Comer Industries.

WORKING TEMPERATURE

The working oil temperature of the drives should range between -20°C and $+90^\circ\text{C}$. Temperatures falling outside this range might be tolerated only if special lubricants and gaskets are used. For further information, please contact the Comer Industries Technical-Commercial Service Department.

BETRIEBSTEMPERATUR

Die Getriebe können bei einer Umgebungstemperatur zwischen -20°C und $+90^\circ\text{C}$ betrieben werden. Ein Betrieb bei Temperaturen außerhalb dieses Bereiches ist möglich, vorausgesetzt daß besondere Maßnahmen in Bezug auf verwendete Schmierstoffe und Dichtungen beachtet werden. Diese Maßnahmen können im Einzelfall in Abstimmung mit dem Kundenservice (Sales) von Comer Industries entschieden werden.

POTENZA TERMICA

P_t [kW]

È la potenza massima trasmissibile dal riduttore in funzionamento continuo con lubrificazione normale a sbattimento, senza che l'olio superi la temperatura di 90°C .

I valori di P_t riportati nelle singole schede tecniche di prodotto sono valori massimi espressi alle seguenti condizioni di impiego:

- servizio continuo
- velocità $n_1 = 1500 \text{ min}^{-1}$

THERMAL POWER

P_t [kW]

The thermal power is the maximum power the drive can transmit under continuous duty with normal turbulence lubrication and without exceeding an oil temperature of 90°C .

The P_t values shown on the single product technical sheet indicate the maximum values under the following duty conditions:

- continuous duty
- speed $n_1 = 1500 \text{ min}^{-1}$

THERMISCHE LEISTUNG

P_t [kW]

Es handelt sich um die maximale Leistung, die das Getriebe bei Dauerbetrieb und normaler Schmierweise übertragen kann, ohne daß die Öltemperatur von 90°C überschritten wird.

Die in den jeweiligen technischen Datenblättern aufgeführten P_t -Werten sind Maximalwerte unter den folgenden Betriebsbedingungen:

- Dauerbetrieb ohne Unterbrechungen
- Drehzahl $n_1 = 1500 \text{ min}^{-1}$

Pour le choix du réducteur, cette valeur doit être mise en rapport avec CONSTATE DE DURÉE n_xh indiquée dans le Diagramme 1 où:

n = vitesse de sortie (min^{-1})

h = durée de fonctionnement (heures)

Pour simplifier la consultation, les fiches techniques des produits indiquent les valeurs de M_c correspondant à une valeur n_2xh prédéterminée.

Para la elección del reductor, este valor representa la CONSTATE DEL TIEMPO DE VIDA n_xh como se muestra en el Diagrama 1 donde:

n = velocidad en la salida (min^{-1})

h = duración de funcionamiento (horas).

Para simplificar la consulta, en la ficha técnica del producto se indican los valores de M_c correspondientes a un valor n_2xh prefijado.

Para escolher o redutor, este valor deve ser relacionado com a CONSTATE DE DURAÇÃO n_xh expressa no Diagrama 1, onde:

n = velocidade de saída (min^{-1})

h = duração de funcionamento (horas).

Para simplificar a consulta, na ficha técnica do produto são indicados os valores de M_c correspondentes a um valor n_2xh prefixado.

COUPLE MAXIMAL

M_{\max} [kNm]

Il s'agit de la valeur maximum de couple que le réducteur peut transmettre pendant une courte durée, sans que ni ses composants internes ni sa structure ne subissent de dommages. Cette valeur doit être considérée comme un couple maximum lors de pics ou lors de mises en marche et ne doit jamais être envisagée comme couple de fonctionnement. La valeur M_{\max} doit en outre être bien évaluée sur les actionnements qui prévoient un grand nombre de mises en marche ou d'inversions. La valeur M_{\max} est indiquée sur chaque fiche technique de produit.

MÁXIMO MOMENTO DE TORSIÓN

M_{\max} [kNm]

Es el máximo valor del momento de torsión que el reductor puede transmitir durante un tiempo breve sin que se produzcan daños en sus componentes internos y estructura. Dicho valor se tiene que considerar como el máximo momento de torsión debido al trabajo o a picos de arranque y jamás como un momento continuo de trabajo. Además, el valor M_{\max} se tendrá que evaluar en aquellos accionamientos que requieran un gran número de arranques o inversiones. El valor M_{\max} se indica en las fichas técnicas del producto.

TORQUE MÁXIMO

M_{\max} [kNm]

É o valor máximo de torque que o redutor pode transmitir durante um breve intervalo de tempo sem que ocorram danos nos seus componentes internos e na sua estrutura. Este valor deve ser considerado como um torque máximo decorrente de picos de funcionamento ou de arranque e nunca como torque de trabalho; além disso, o valor M_{\max} deve ser cuidadosamente avaliado nos acionamentos que exigem um número elevado de arranques ou de inversões. O valor M_{\max} é indicado nas fichas técnicas do produto.

TEMPERATURE DE FONCTIONNEMENT

Les températures de l'huile auxquelles les réducteurs peuvent fonctionner sont celles comprises entre -20°C et $+90^{\circ}\text{C}$. Des températures hors de cette plage sont acceptables à condition de prendre des précautions spécifiques concernant le type de lubrifiant et les joints utilisés.

Ces précautions sont à établir au cas par cas, en accord avec le Service Technico-Commercial Comer Industries.

TEMPERATURA DE FUNCIONAMIENTO

Las temperaturas del aceite para las cuales los reductores pueden funcionar tienen que estar comprendidas entre -20°C y $+90^{\circ}\text{C}$. Se pueden aceptar temperaturas fuera de esta faja si se prevén particulares precauciones respecto a los tipos de lubricante y de garniciones utilizadas. Dichas precauciones se pueden establecer según el caso, poniéndose de acuerdo con el Servicio Técnico-Comercial de Comer Industries.

TEMPERATURA DE FUNCIONAMENTO

As temperaturas do óleo com as quais os reductores podem funcionar vão de -20°C a $+90^{\circ}\text{C}$. Valores de temperatura fora desta faixa só podem ser admitidas se forem empregadas precauções especiais para o que se refere aos óleos e às garnições. Estas precauções podem ser decididas caso a caso, consultando o Serviço Técnico Comercial da Comer Industries.

PUISSANCE THERMIQUE

P_t [kW]

Il s'agit de la puissance maximale transmissible par le réducteur en fonctionnement continu en conditions de lubrification standard par barbotage, sans que l'huile ne dépasse la température de 90°C .

Les valeurs de P_t indiquées sur chaque fiche technique sont des valeurs maximales établies dans les conditions d'utilisation suivantes:

- service continu
- vitesse $n_1 = 1500 \text{ min}^{-1}$

POTENCIA TÉRMICA

P_t [kW]

Es la potencia máxima que puede transmitir el reductor durante el funcionamiento continuo con lubricación normal por circulación y salpicadura y sin que el aceite supere los 90°C .

Los valores de P_t indicados en cada una de las fichas técnicas del producto son los máximos valores para las siguientes condiciones de utilización:

- servicio continuo
- velocidad $n_1 = 1500 \text{ min}^{-1}$

POTÊNCIA TÉRMICA

É a potência máxima que pode ser transmitida pelo redutor em funcionamento contínuo com lubrificação normal por chapinhagem, sem que a temperatura do óleo ultrapasse 90°C .

Os valores de P_t indicados nas fichas técnicas de produto representam valores máximos expressos nas seguintes condições de emprego:

- serviço contínuo
- velocidade $n_1 = 1500 \text{ min}^{-1}$



CARATTERISTICHE TECNICHE

- olio ISO VG 150
- posizione di montaggio orizzontale
- temperatura ambiente 20°C.

Qualora la potenza richiesta ecceda i valori indicati nella scheda tecnica del riduttore sarà necessario prevedere un sistema di raffreddamento del lubrificante.

Per i riduttori con piedi (dalla grandezza PG 100 alla grandezza PG 1600) il valore di Pt può essere incrementato del 15%.

Nel caso le caratteristiche di impiego siano diverse, si può applicare ai valori di Pt un fattore correttivo f_k , come indica la Tabella 1, di seguito riportata:



TECHNICAL INFORMATION

- oil ISO VG 150
- horizontal mounting position
- Room temperature 20°C.

If the required power exceeds the values indicated on the drive technical sheet, a lubricant cooling system must be installed.

For foot-mounted drives (from the PG 100 to the PG 1600 series), the Pt value can be increased by 15%.

If the duty characteristics differ, you can apply a corrective factor f_k to the Pt values as indicated in Table 1 below:



TECHNISCHE EIGENSCHAFTEN

- Öl ISO VG 150
- waagerechte Einbaulage
- Umgebungstemperatur +20°C

Sollte die geforderte Leistung die im technischen Datenblatt des Getriebes aufgeführten Werte übersteigen, wird ein Schmiermittel-Kühlsystem erforderlich.

Der Pt- Wert der Getriebe in Fussausführung (von Größe PG 100 bis PG 1600) kann um 15% erhöht werden.

Weichen die Einsatzbedingungen von den Normbedingungen ab, können die Pt-Werte durch den Korrekturfaktor f_k korrigiert werden (vgl. nachstehend aufgeführte Tabelle 1):

$$Pt_1 = Pt \times f_k$$

Fattore di adeguamento della capacità termica f_k Thermal power adjustment factor f_k Anpassungsfaktor Wärmekapazität f_k					
Tempo % di funzionamento Work time % Betriebszeit in %	Temperatura ambiente °C / Room temperature °C / Raumtemperatur in C°				
	10°	20°	30°	40°	50°
100	1.1	1.0	0.8	0.7	0.6
80	1.2	1.1	1.0	0.8	0.7
60	1.4	1.2	1.1	1.0	0.8
40	1.6	1.4	1.2	1.1	1.0
20	1.8	1.6	1.4	1.2	1.1

Tabella 1 / Table 1 / Tabelle 1

N.B. Si noti che la Pt è riferita alla potenza effettivamente trasmessa dal riduttore, da non confondere quindi con la potenza del motore su di esso installato, che per vari motivi potrebbe essere superiore.

Per ulteriori dettagli si prega di contattare il Servizio Tecnico-Commerciale Comer Industries.

FATTORE DI SERVIZIO

f_s

È un coefficiente di moltiplicazione che viene inserito nella formula per la scelta del riduttore.

Serve per tener conto delle condizioni di carico dell'applicazione, ed è definito dalla Tabella 2

NOTE. Pt refers to the power actually transmitted by the drive. It should not be confused with the power of the motor mounted on the drive which, for various reasons, might be higher.

For further details please contact the Comer Industries Technical-Commercial Service Department.

SERVICE FACTOR

f_s

Service factor f_s is a multiplication coefficient introduced into the formula for selecting the drive.

This factor takes into account the application load conditions. It is defined in Table 2.

ANMERKUNG: Es wird darauf hingewiesen, daß sich der Pt- Wert auf die tatsächlich vom Getriebe übertragene Leistung bezieht; sie darf nicht mit der Leistung des eingebauten Motors verwechselt werden, die höher sein könnte.

Für weitere Rückfragen wenden Sie sich bitte an den Kundenservice (Sales) von Comer Industries.

BETRIEBSFAKTOR

f_s

Es handelt sich um einen Multiplikationskoeffizienten, der in die Formel eingesetzt wird.

Damit soll den nach Einsatzform unterschiedlichen Belastungen Rechnung getragen werden; er wird in Tabelle 2 aufgeführt.

CARACTERISTIQUES
TECHNIQUES



- huile ISO VG 150
- position de montage horizontale
- température ambiante 20°C.

Si la puissance requise dépasse les valeurs indiquées sur la fiche technique du réducteur, il est nécessaire de prévoir l'installation d'un système de refroidissement du lubrifiant

Pour les réducteurs à pattes, (de la grandeur PG 100 à la grandeur PG 1600) la valeur Pt peut être majorée de 15%.

Dans le cas où les caractéristiques d'utilisation seraient différentes, il est possible d'appliquer un facteur correctif fk, comme indiqué dans le Tableau 1 ci-dessous:

CARACTERÍSTICAS
TÉCNICAS



- aceite ISO VG 150
- posición de montaje horizontal
- temperatura ambiente 20°C.

Si la potencia requerida excede los valores indicados en la ficha técnica del reductor será necesario prever un sistema de enfriamiento del lubricante.

Para los reductores con pie (desde la serie PG 100 hasta PG 1600) el valor de Pt se puede incrementar el 15%.

Si las características de empleo son distintas, a los valores de Pt se les puede aplicar un factor de corrección fk, como se indica en la siguiente Tabla 1:

CARACTERÍSTICAS
TÉCNICAS



- óleo ISO VG 150
- posição de montagem horizontal
- temperatura ambiente de 20°C.

Se a potência requerida ultrapassar os valores indicados na ficha técnica do reductor, será necessário instalar um sistema de esfriamento do lubrificante.

Para os redutores com pés (do tamanho PG 100 ao tamanho PG 1600), o valor de Pt pode ser aumentado em 15%.

Se as características de emprego forem diferentes, pode-se aplicar aos valores de Pt um fator de correção fk, conforme indicado na Tabela 1 reproduzida a seguir:

INTR.

$$Pt_1 = Pt \times fk$$

Facteur d'adaptation de la capacité thermique fk Factor de adaptación de la capacidad térmica fk Fator de adaptação da capacidade térmica fk					
Temps % de fonctionnement Tiempo % de funcionamiento Tempo % de funcionamento	Température Ambiante °C / Temperatura ambiente °C / Temperatura ambiente °C				
	10°	20°	30°	40°	50°
100	1.1	1.0	0.8	0.7	0.6
80	1.2	1.1	1.0	0.8	0.7
60	1.4	1.2	1.1	1.0	0.8
40	1.6	1.4	1.2	1.1	1.0
20	1.8	1.6	1.4	1.2	1.1

Tableau 1 / Tabla 1 / Tabela 1

N.B. Pt se réfère à la puissance effectivement transmise par le réducteur; il est important de ne pas confondre cette valeur avec la puissance du moteur sur lequel le réducteur est installé, puissance qui, pour différentes raisons, peut être supérieure.

Pour plus de détails, s'adresser au Service Technico-Commercial Comer Industries.

Nota: tener en cuenta que la Pt se refiere a la potencia efectivamente transmitida por el reductor, por tanto no hay que confundirse con la potencia del motor instalado sobre el mismo, que por distintos motivos podría ser superior.

Para más detalles se aconseja ponerse en contacto con el Servicio Técnico-Comercial de Comer Industries.

OBS.: é importante ressaltar que a Pt refere-se à potência efetivamente transmitida pelo reductor, não devendo ser confundida com a potência do motor instalado nele que, por vários motivos, pode ser superior.

Para maiores informações, entre em contato com o Serviço Técnico Comercial da Comer Industries.

FACTEUR DE SERVICE
fs

Il s'agit d'un coefficient de multiplication qui est introduit dans la formule servant à choisir le réducteur.

Il permet de tenir compte des conditions de charge de l'application et est défini dans le Tableau 2.

FACTOR DE SERVICIO
fs

Es un coeficiente de multiplicación que se introduce en la fórmula para la elección del reductor.

Sirve para tener en cuenta las condiciones de carga de la aplicación y está definido en la Tabla 2.

FATOR DE SERVIÇO
fs

É um coeficiente de multiplicação que é introduzido na fórmula para a escolha do reductor.

Serve para considerar as condições de carga da aplicação, sendo definido pela Tabela 2.



CARATTERISTICHE TECNICHE



TECHNICAL INFORMATION



TECHNISCHE EIGENSCHAFTEN

CARICHI SULL'ALBERO DI USCITA E ENTRATA Fr ; Fa [N]

Fr =carico radiale
Fa =carico assiale

I valori dei carichi applicabili sugli alberi di uscita si ricavano dai diagrammi riportati in corrispondenza di ogni grandezza di riduttore, mentre quelli relativi agli alberi di entrata si trovano a pag. D-4.

I carichi radiali ed assiali massimi non possono agire contemporaneamente.

L'entità dei carichi ammessi Fr , Fa è riferita ad una durata dei cuscinetti secondo ISO 281, corrispondente a:

$n \times h = 10^5$ per alberi di uscita

$n \times h = 5 \times 10^6$ per alberi in entrata

I riduttori in versione F vengono normalmente utilizzati per trasmettere coppia senza carichi radiali, pertanto non vengono indicate le capacità di Fr ed Fa massime.

Per informazioni ulteriori contattare il Servizio Tecnico-Commerciale Comer Industries.

OUTPUT AND INPUT SHAFT LOADS Fr ; Fa [N]

Fr = radial load
Fa = axial load

The load values that output shafts can bear are indicated on the load curves shown for each drive size; the load values relevant to input shafts are shown on page D-4.

Maximum radial and axial loads must not occur simultaneously.

The values of the tolerated loads Fr, Fa refer to a bearing duration, according to standard ISO 281, corresponding to:

$n \times h = 10^5$ for output shafts

$n \times h = 5 \times 10^6$ for input shafts

F gear units are usually applied in the transmission of a torque without radial loads. In this case, maximum values Fr and Fa are not shown.

For further information, please contact the Comer Industries Technical-Commercial Service Department.

BELASTUNG DER ABTRIEBSWELLE UND ANTRIEBSWELLE Fr ; Fa [N]

Fr = Radiallast
Fa = Axiallast

Die Belastbarkeit der Abtriebswelle ergibt sich aus den jeder Getriebegröße zugeordneten Diagrammen. Dagegen sind die Werte der Antriebswelle auf der S. D-4 ersichtlich.

Die zulässigen Maximalwerte der Radial- und Axialbelastungen dürfen nicht gleichzeitig auftreten.

Der Wert der zulässigen Belastung durch Fr und Fa bezieht sich auf eine Betriebsdauer nach ISO 281, das entspricht:

$n \times h = 10^5$ fuer Abtriebswelle

$n \times h = 5 \times 10^6$ fuer Antriebswelle

Die Getriebe in Ausführung F werden in der Regel für die Übertragung von Drehmomenten ohne Radialbelastung eingesetzt. Deshalb werden Fr und Fa nicht angegeben. Für weitere Rückfragen wenden Sie sich bitte an den Kundenservice (Sales) von Comer Industries.

Nell'ambito del continuo sviluppo e miglioramento del prodotto, la Comer Industries si riserva la facoltà di apportare le modifiche sia tecniche sia dimensionali che saranno ritenute opportune, senza darne espresso preavviso.

Because Comer Industries is continuously improving its product, it will make the technical and dimensional changes deemed necessary, without notifying the market in advance.

Im Rahmen der ständigen Weiterentwicklung und Verbesserung der Produkte behält sich Comer Industries das Recht vor, erforderliche technische Änderungen ohne ausdrückliche Vorankündigung durchzuführen.

SCELTA DEL RIDUTTORE

In una trasmissione meccanica, il riduttore è un organo inserito tra motore ed utenza. Le sollecitazioni a cui è sottoposto durante il funzionamento sono funzione delle curve caratteristiche del motore come di quelle dell'utenza (assorbimento e ciclo di lavoro).

La conoscenza della trasmissione nella sua interezza è condizione necessaria per la corretta scelta del riduttore.

È necessario conoscere:

UTENZA

- a) tipo di servizio
- b) velocità di rotazione
- c) potenza e/o coppia assortita
- d) ciclo di lavoro

MOTORE

- e) tipo e caratteristiche del motore
- f) potenza e/o coppia erogata
- g) velocità di funzionamento

DRIVE SELECTION

In a mechanical transmission system, a drive is a device positioned between the prime mover and the driven equipment. The stress it is subjected to during operation is strictly related to the characteristics of the prime mover and the driven equipment (power absorption and work cycle).

Knowledge of the entire transmission system is mandatory to choose the best drive.

It is necessary to know the following:

DRIVEN EQUIPEMENT

- a) type of operation
- b) rotation speed
- c) power and/or torque absorption
- d) working cycle

PRIME MOVER

- e) type and characteristics of the prime mover
- f) delivered power and/or torque
- g) operating speed

GETRIEBEAUSWAHL

In einem mechanischen System ist das Getriebe eine Einheit zwischen Motor und anzutreibender Maschine. Die Belastungen die auf dem Getriebe während des Betriebes wirken, sind eine Funktion sowohl der Motor-als auch der Maschinenkennlinie (Leistungsaufnahme und Lastkollektiv).

Die Kenntnis des gesamten Antriebsystems ist Voraussetzung für die korrekte Auswahl des Getriebes. Man sollte folgende Daten berücksichtigen:

ANZUTREIBENDE MASCHINE

- a) Einsatz
- b) Drehgeschwindigkeit
- c) Leistung und/oder
- d) Lastkollektiv

MOTOR

- e) Typ und Eigenschaften des Motors
- f) Leistung und/oder Drehmoment
- g) Drehgeschwindigkeit

**CHARGES SUR L'ARBRE DE SORTIE
ET D'ENTREE** Fr ; Fa [N]

Fr = charge radiale
Fa = charge axiale

Les valeurs des charges applicables sur l'arbre de sortie peuvent être obtenues à partir des diagrammes correspondants à chaque famille de réducteur; celles relatives aux arbres d'entrée sont indiquées page D-4.

Les charges radiales et axiales maximales ne sont pas cumulables.

La valeur des charges admissibles Fr et Fa se réfère à une durée des roulements établie selon la norme ISO 281, à savoir:

$$n \times h = 10^5 \text{ pour arbres de sortie}$$

$$n \times h = 5 \times 10^6 \text{ pour arbres d'entrée}$$

Les réducteurs version F sont généralement utilisés pour transmettre un couple sans charges radiales, aussi les charges maximales Fr et Fa ne sont-elles pas indiquées.

Pour de plus amples informations, s'adresser au Service Technico-Commercial Comer Industries.

**CARGAS EN EL EJE DE SALIDA
Y ENTRADA** Fr ; Fa [N]

Fr = carga radial
Fa = carga axial

Los valores de las cargas aplicables sobre los ejes de salida se obtienen de los diagramas indicados en correspondencia con cada dimensión del reductor, mientras los valores en los ejes de entrada se encuentran en la Pág. D-4.

Las cargas radiales y axiales máximas no pueden intervenir simultáneamente.

El valor de las cargas admitidas Fr, Fa está referido a una duración de los rodamientos según la norma ISO 281 y corresponde a:

$$n \times h = 105 \text{ para ejes de salida}$$

$$n \times h = 5 \times 106 \text{ para ejes de entrada}$$

Los reductores de la versión F generalmente se utilizan para transmitir un momento de torsión sin cargas radiales, por tanto no se indican los valores máximos de Fr y Fa.

Para más informaciones, se recomienda ponerse en contacto con el Servicio Técnico-Comercial de Comer Industries.

**CARGAS NO EIXO DE SAÍDA
E ENTRADA** Fr ; Fa [N]

Fr = carga radial
Fa = carga axial

Os valores das cargas aplicáveis nos eixos de saída são obtidos a partir dos diagramas correspondentes a cada tamanho de redutor. Já os valores relativos aos eixos de entrada, estão indicados na página D-4.

As cargas radiais e axiais máximas não podem atuar simultaneamente.

O valor das cargas admitidas Fr, Fa refere-se a uma duração dos rolamentos segundo ISO 281, correspondente a:

$$n \times h = 105 \text{ para os eixos de saída}$$

$$n \times h = 5 \times 106 \text{ para os eixos de entrada}$$

Os redutores na versão F são utilizados normalmente para transmitir torque sem cargas radiais, não sendo por isso mostradas as capacidades de Fr e Fa máximas.

Para mais informações, entre em contato com o Serviço Técnico Comercial da Comer Industries.

Comer Industries se réserve le droit d'apporter, sans préavis, les modifications de type technique et dimensionnel jugées nécessaires au développement et à l'amélioration constant de ses produits.

Comer Industries continua desarrollando y mejorando sus productos, reservándose la facultad de efectuar las oportunas modificaciones técnicas y dimensionales sin previo aviso.

Por estar comprometida com o desenvolvimento e melhoramento contínuos dos seus produtos, a Comer Industries reserva-se o direito de efetuar as modificações técnicas e/ou dimensionais que considerar adequadas sem aviso prévio expresso.

SELECTION DU REDUCTEUR

Dans un système de transmission mécanique, le réducteur est un organe situé entre le moteur et la machine à actionner. Les sollicitations auxquelles il est soumis pendant le fonctionnement sont fonction des courbes caractéristiques du moteur ainsi que de celles la machine à actionner (absorption de puissance et cycle de travail). La connaissance du système de transmission dans son intégralité est une condition indispensable au choix du réducteur répondant aux besoins effectifs.

Ainsi est-il nécessaire de connaître:

MACHINE A ACTIONNER

- a) type de service
- b) vitesse de rotation
- c) puissance et/ou couple absorbé et/ou couple
- d) cycle de travail

MOTEUR

- e) type et caractéristiques du moteur
- f) puissance et/ou couple produits
- g) vitesse de fonctionnement

ELECCIÓN DEL REDUCTOR

En una transmisión mecánica el reductor es un órgano situado entre el motor y el equipo conducido. Las sollicitaciones a las que se somete durante el funcionamiento son función de las curvas características del motor y del equipo conducido (potencia absorbida y ciclo de trabajo).

El conocimiento del sistema de transmisión es una condición necesaria para la correcta elección del reductor. Será necesario conocer:

EQUIPO CONDUCIDO

- a) tipo de servicio
- b) velocidad de rotación
- c) potencia y/o momento de torsión absorbido
- d) ciclo de trabajo

MOTOR

- e) tipo y características del motor
- f) potencia y/o momento de torsión erogado
- g) velocidad de funcionamiento

ESCOLHA DO REDUTOR

Em um sistema de transmissão mecânica, o redutor é um órgão instalado entre o motor e o equipamento a ser acionado. As sollicitações às quais é submetido durante o funcionamento dependem das curvas características tanto do motor, como do equipamento (absorção e ciclo de trabalho).

O conhecimento de todas as características do sistema de transmissão é uma condição fundamental para escolher o redutor mais adequado. É preciso conhecer:

EQUIPAMENTO A SER ACIONADO

- a) tipo de serviço
- b) velocidade de rotação
- c) potência e/ou torque absorvido
- d) ciclo de trabalho

MOTOR

- e) tipo e características do motor
- f) potência e/ou torque fornecido
- g) velocidade de funcionamento



CARATTERISTICHE TECNICHE

Queste informazioni permettono una prima scelta dei riduttori dopo aver determinato:

- rapporto di trasmissione i
- coppia di lavoro M [kNm]
- carichi sull'albero in uscita e in entrata al riduttore F_r ; F_a [N]

Successivamente si dovrà procedere alle verifiche dei parametri caratteristici dei riduttori come segue:

- velocità in ingresso al riduttore $\leq n_1 \text{ max}$
- coppia di lavoro $\leq M_c$
- carichi applicati all'albero in uscita e in entrata $\leq F_r$; F_a
- potenza da trasmettere $\leq P_t$ (se in servizio continuo)
- temperatura ambiente

Le relazioni I e V sono di immediata verifica mentre per la II, la III e la IV si procede come segue:



TECHNICAL INFORMATION

With this information an initial drive selection can be made, determining the following:

- reduction ratio i
- working torque M [kNm]
- loads F_r and F_a [N] on drive output and input shafts

Subsequently, we must verify some specific drive parameters as follows::

- drive input rotation speed $\leq n_1 \text{ max}$
- working torque $\leq M_c$
- loads on output and input shafts $\leq F_r$; F_a
- horsepower to be transmitted $\leq P_t$ (if under continuous duty)
- room temperature

Relations I and V can be readily verified; as for relations II, III and IV we must proceed as follows:



TECHNISCHE EIGENSCHAFTEN

Diese Daten ermöglichen eine erste Auswahl des Getriebes und zwar nach der Festlegung von:

- Übersetzung i
- Arbeitsdrehmoment M [kNm]
- Belastung an der Abtriebs- und Antriebswelle F_r , F_a [N]

Danach sind folgende Parameter zu überprüfen:

- Getriebedrehzahl $\leq n_1 \text{ max}$
- Betriebsdrehmoment $\leq M_c$
- Belastungen auf der Abtriebswelle und Antriebswelle $\leq F_r$; F_a
- Wärmeleistung $\leq P_t$ (Dauerbetrieb)
- Umgebungstemperatur

Die Parameter I und V kann man ohne weiteres prüfen. Was II, III und IV betrifft, ist wie folgt vorzugehen:

VERIFICA DEL RIDUTTORE IN FUNZIONE DELLA COPPIA

Calcolo della coppia equivalente M_e [kNm]

Quando il carico è variabile nel tempo (Istogramma 1), si deve determinare il valore della coppia equivalente.

Con il criterio del cumulativo di carico si calcola, con la formula sotto indicata, la coppia in grado di provocare lo stesso livello di usura dopo il numero di cicli ($n \times h$) richiesto dal progetto.

VERIFICATION OF THE PLANETARY UNIT ACCORDING TO THE TORQUE

Calculation of the equivalent working torque M_e [kNm]

When loads are intermittent (see Histogram 1), we must determine the equivalent working torque value.

The cumulative load principle, based on the following formula, is used to determine the torque value which produces the same fatigue after the number of cycles ($n \times h$) required by the project:

ÜBERPRÜFUNG DES GETRIEBES AUFGRUND DES DREHMOMENTS

Berechnung des äquivalenten Drehmoments M_e [kNm]

Wenn die Belastung während der Einsatzdauer variiert (siehe z.B. Diagramm 1), soll man einen Durchschnittswert ermitteln.

Nach dem Lastkollektiv wird das Drehmoment mit der unten angegebenen Formel berechnet.

$$M_e = \sqrt[6]{M_1^6 \frac{(n_1 \times h_1)}{(n \times h)} + M_2^6 \frac{(n_2 \times h_2)}{(n \times h)} + M_3^6 \frac{(n_3 \times h_3)}{(n \times h)}}$$

Istogramma 1
Histogram 1
Histogramm 1

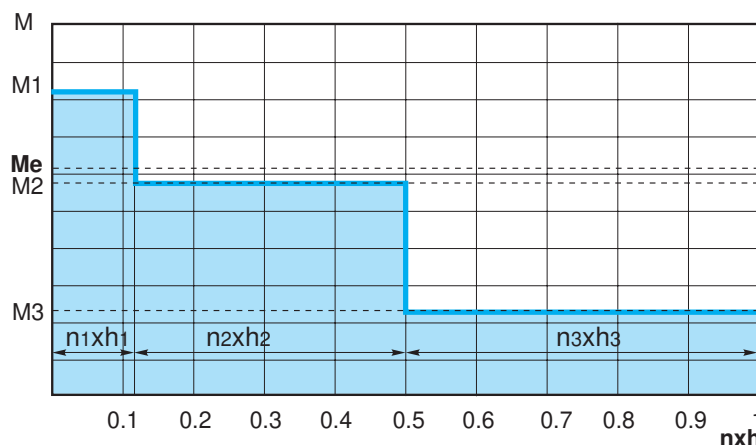

Ces informations permettent une première sélection après avoir établi:

- rapport de transmission i
- couple de travail M [kNm]
- charges sur l'arbre de sortie et d'entrée sur le réducteur F_r ; F_a [N]

Ensuite, il est nécessaire de procéder aux contrôles des paramètres spécifiques des réducteurs, comme suit:

- vitesse en entrée sur le réducteur $\leq n_1$ max
- Couple de travail $\leq M_c$
- charges appliquées sur l'arbre en sortie et en entrée $\leq F_r$; F_a
- Puissance à transmettre $\leq P_t$ (si le service est de type continu)
- température ambiante

Les paramètres I et V peuvent être calculés directement alors que pour les paramètres II, III et IV, il est nécessaire de procéder comme suit:

CONTRÔLE DU RÉDUCTEUR EN FONCTION DU COUPLE

Calcul du couple équivalent M_e [kNm]

Lorsque la charge varie dans le temps (voir histogramme 1), il est nécessaire d'établir la valeur du couple équivalent.

Par l'intermédiaire du critère du cumul des charges est calculée, au moyen de la formule ci-dessous, la valeur de couple qui détermine le même niveau d'usure à l'issue du nombre de cycles ($n_x h$) requis par le projet.

Estas informaciones permiten una primer elección de los reductores después de haber determinado:

- relación de transmisión i
- momento de trabajo M [kNm]
- cargas en el eje de salida y entrada del reductor F_r ; F_a [N]

Después se tendrán que efectuar las verificaciones de los parámetros característicos de los reductores como sigue:

- velocidad de entrada en el reductor $\leq n_1$ máx.
- momento de trabajo III) cargas aplicadas en el eje de salida y entrada $\leq M_c$
- cargas aplicadas en el eje de salida y entrada $\leq F_r$; F_a
- potencia a transmitir $\leq P_t$ (si el servicio es conuuo)
- temperatura ambiente

Las relaciones I y V se verifican directamente mientras para las II, III y IV se procede como sigue:

VERIFICACIÓN DEL REDUCTOR SEGÚN EL MOMENTO DE TORSIÓN

Cálculo del momento equivalente M_e [kNm]

Cuando la carga varía durante el tiempo (Histograma 1), se tendrá que determinar el valor del momento equivalente.

Se emplea el criterio de la carga acumulada para calcular, con la fórmula abajo indicada, el momento capaz de producir el mismo nivel de desgaste para el número de ciclos ($n_x h$) requerido por el proyecto.

Estas informações possibilitam uma primeira seleção dos reductores após a determinação de:

- relação de transmissão i
- torque de trabalho M [kNm]
- cargas no eixo de saída e de entrada no reductor F_r ; F_a [N]

Em seguida, deve-se passar às verificações dos parâmetros característicos dos reductores conforme indicado a seguir:

- velocidade na entrada do reductor $\leq n_1$ máx
- torque de trabalho $\leq M_c$
- cargas aplicadas no eixo de saída e de entrada $\leq F_r$; F_a
- potência que deve ser transmitida $\leq P_t$ (se em serviço contínuo)
- temperatura ambiente

As relações I e V são verificáveis imediatamente, enquanto que para verificar as relações II, III e IV, procede-se da seguinte maneira:

VERIFICAÇÃO DO REDUTOR EM FUNÇÃO DO TORQUE

Cálculo do torque equivalente M_e [kNm]

Quando a carga varia com o tempo (Histograma 1), deve-se determinar o valor do torque equivalente.

Adotando o princípio da carga cumulativa, calcula-se, com a fórmula indicada abaixo, o torque que produz o mesmo nível de desgaste após o número de ciclos ($n_x h$) requerido pelo projeto.

$$M_e = \sqrt[6]{M_1^6 \frac{(n_1 \times h_1)}{(n \times h)} + M_2^6 \frac{(n_2 \times h_2)}{(n \times h)} + M_3^6 \frac{(n_3 \times h_3)}{(n \times h)}}$$

Histogramme 1
Histogram 1
Histogramm 1

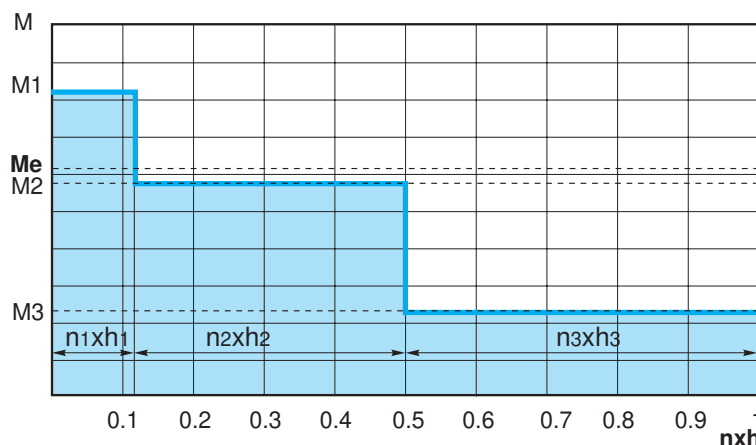

Fattore di durata fh

Nelle applicazioni industriali o di norma quando il numero di cicli di lavoro previsto n_xh supera 2×10^4 , si rende necessario introdurre un fattore di durata f_h (con l'ausilio del Diagramma 1) per adeguare il valore della coppia di catalogo M_c ad un valore che permetta di raggiungere il numero di cicli (n_xh) designato a progetto.

Duration factor fh

In industrial installations and whenever the number of working cycles n_xh exceeds 2×10^4 , we must consider a duration factor f_h (see Curve 1) in order to adapt the M_c torque shown in the catalogue to a new value which allows the machine to operate at the number of cycles (n_xh) required by the project.

Lebensdauerfaktor fh

Sollte die sich nach dem Einsatz ergebende Anzahl von Arbeitszyklen den Wert 2×10^4 übersteigen, dann ist mit Hilfe des Diagramms 1 f_h auszuwählen. Auf diese Weise wird der Katalogwert M_c an die tatsächliche Vorgabe n_xh angepasst.

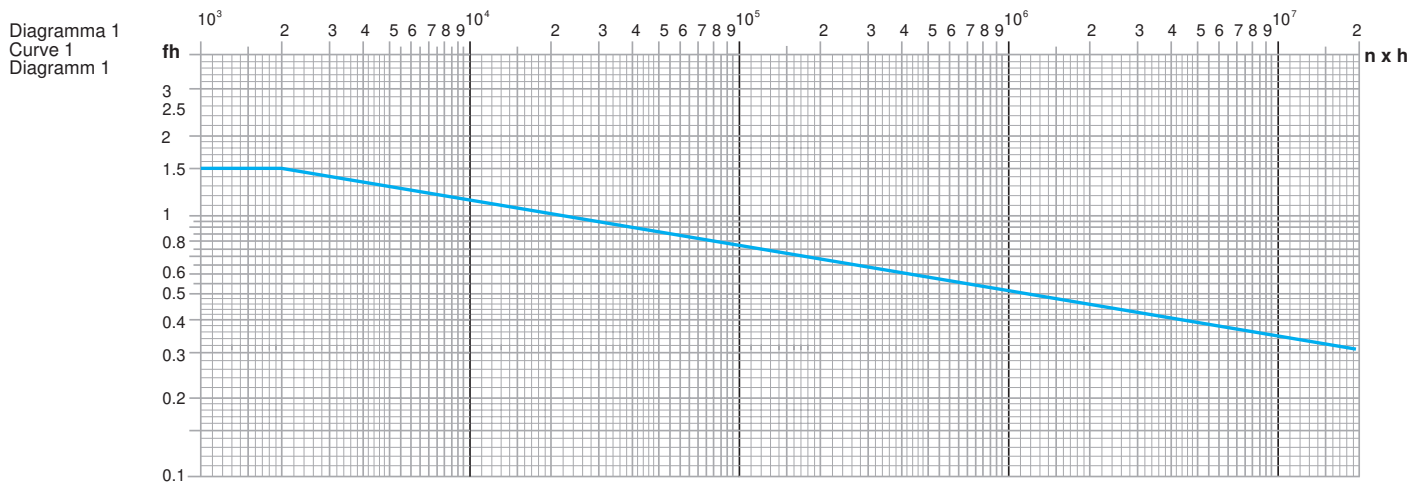
**Determinazione del fattore di servizio fs**

L'effetto degli urti derivanti da irregolarità del moto, dai sovraccarichi nei transitori di velocità (avviamenti ed arresti), viene conteggiato introducendo un fattore di servizio f_s .
La Tabella 2 indica i fattori f_s in funzione del tipo di applicazione.

Service factor fs calculation

The effect of shocks generated by intermittent motion and overloads during starts and stops must be calculated, introducing a service factor f_s .
Table 2 indicates the service factors f_s in relation to the type of operation.

Betriebsfaktor fs

Die Stöße die auf Unregelmässigkeit des Betriebes zurückzuführen sind, sowie die Spitzenbelastungen während des Einschalt- oder Bremsvorgangs werden mittels des Betriebsfaktors berücksichtigt.
Die Tabelle 2 zeigt die Betriebsfaktoren f_s eingestuft nach Einsatzbedingungen

	Condizioni di carico / Load classifications / Belastungskennwert											
	U Uniforme / Uniform Gleichmässig				M Moderato / Moderate Mittelschwer				H Pesante / Heavy Schwer			
Ore-giorno / Hours-day Stunden pro Tag	< 1.0	1 - 4	4 - 8	8 - 24	< 1.0	1 - 4	4 - 8	8 - 24	< 1.0	1 - 4	4 - 8	8 - 24
Avviamenti-ora Start-time Starts pro Stunde												
< 5	0.8	0.9	1.0	1.5	0.9	1.0	1.3	1.9	1.0	1.5	1.9	2.4
5 - 50	1.0	1.0	1.4	1.7	1.0	1.3	1.6	1.9	1.4	1.8	2.1	2.5
> 50	1.3	1.5	1.7	1.9	1.4	1.7	1.9	2.2	1.7	2.1	2.5	2.9
	fs											

Tabella 2 / Table 2 / Tabelle 2

I valori riportati sono per azionamento con motori idraulici e elettrici.
Nel caso vengano utilizzati altri tipi di motori (combustione interna), contattare il nostro Servizio Tecnico-Commerciale.

Operating values refer to drives with hydraulic and electric motors.
If other types of motors are operated (internal combustion engine), please contact our Technical-Commercial Service Department.

Die Werte gelten bei Betrieb mit Hydraulik- und Elektromotor.
Wenn die Einheiten unter abweichenden Bedingungen verwendet bzw. werden abweichende Motortypen (Verbrennungsmotore) verwendet, setzen Sie sich bitte mit unserem Kundenservice (sales) in Verbindung.

Facteur de duree fh

Sur toutes les applications du secteur industriel ou lorsque le nombre de cycles de travail prévu $n \times h$ dépasse 2×10^4 , il est nécessaire d'introduire un facteur de durée fh (à l'aide du diagramme 1) dans le but d'adapter la valeur du couple de catalogue Mc à une valeur qui permette d'atteindre le nombre de cycles ($n \times h$) requis par le projet.

Factor de desgaste fh

En las aplicaciones industriales o en general cuando el número de ciclos de trabajo previsto $n \times h$ supera 2×10^4 , será necesario introducir un factor de duración fh (con la ayuda del Diagrama 1) para adecuar el valor del momento indicado en el catálogo Mc a un valor que permita alcanzar el número de ciclos ($n \times h$) requerido en el proyecto.

Fator de duração fh

Nas aplicações industriais ou, normalmente, quando o número de ciclos de trabalho $n \times h$ ultrapassa 2×10^4 , torna-se necessário introduzir um fator de duração fh (com o auxílio do Diagrama 1) para adequar o valor de torque indicado no catálogo Mc a um valor que permita atingir o número de ciclos ($n \times h$) designado no projeto.

INTR.

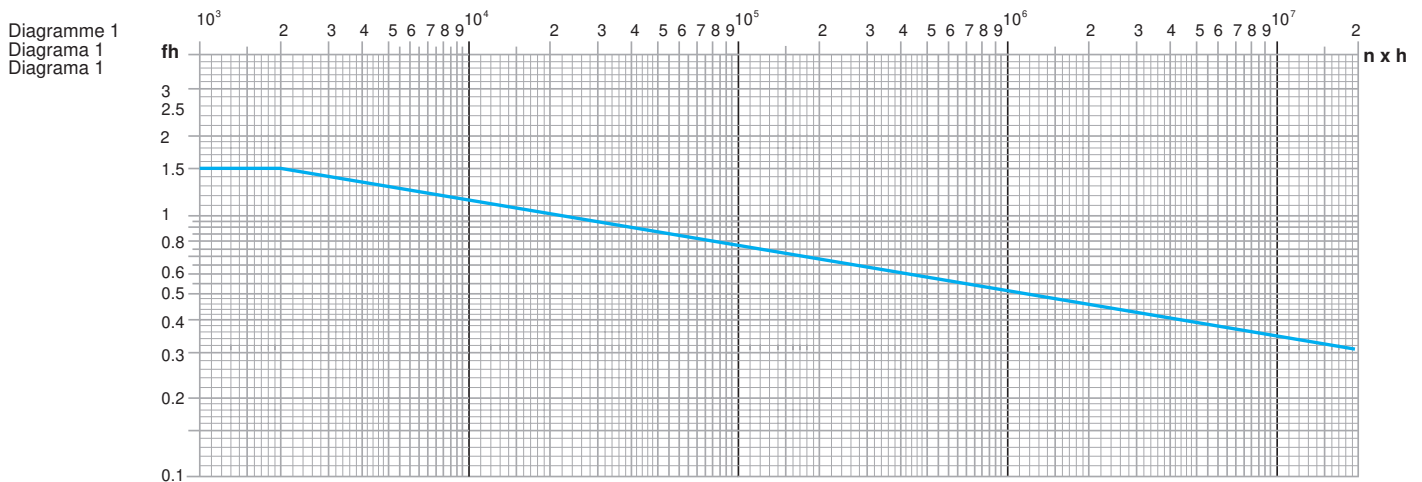

Calcul du facteur de service fs

L'effet des chocs résultant des irrégularités de mouvement, des surcharges lors des pics de vitesse (mises en marche et arrêts) est pris en compte en introduisant un facteur de service fs. Le Tableau 2 indique les facteurs fs selon le type d'application.

Determinación del factor de servicio fs

El efecto de los choques ocasionados por la irregularidad del movimiento y las sobrecargas (durante las puestas en marcha y las detenciones) se deberá calcular introduciendo un factor de servicio fs. La Tabla 2 indica los factores fs en función del tipo de aplicación.

Determinação do fator de serviço fs

O efeito dos choques resultantes da irregularidade do movimento e das sobrecargas nos picos de velocidade (arranques e paradas), é calculado através da introdução de um fator de serviço fs. A Tabela 2 indica os fatores fs em função do tipo de aplicação.

Heures-jour / Horas-día / Horas por dia	Conditions de charge / Condiciones de carga / Condições de carga												
	U Uniforme / Uniforme / Uniforme				M Moyenne / Moderado / Moderada				H Lourde / Pesado / Pesada				
	< 1.0	1 - 4	4 - 8	8 - 24	< 1.0	1 - 4	4 - 8	8 - 24	< 1.0	1 - 4	4 - 8	8 - 24	
Demarrages par heure Puestas en marcha-horas Arranques por hora	< 5	0.8	0.9	1.0	1.5	0.9	1.0	1.3	1.9	1.0	1.5	1.9	2.4
	5 - 50	1.0	1.0	1.4	1.7	1.0	1.3	1.6	1.9	1.4	1.8	2.1	2.5
	> 50	1.3	1.5	1.7	1.9	1.4	1.7	1.9	2.2	1.7	2.1	2.5	2.9
fs													

Tableau 2 / Tabla 2 / Tabela 2

Les valeurs sont indiquées pour des actionnements à moteurs hydrauliques et électriques. Pour l'utilisation d'autres types de moteur (à combustion interne), prendre contact avec le Service Technico-Commercial.

Los valores indicados son para accionamiento con motores hidráulicos y eléctricos. Si se utilizaran otros tipos de motores (combustión interna), se aconseja ponerse en contacto con nuestro Servicio Técnico-Comercial.

Os valores indicados são válidos para acionamento com motores hidráulicos e elétricos. Se utilizar outros tipos de motores (de combustão interna), entre em contato com o nosso Serviço Técnico Comercial.



CARATTERISTICHE TECNICHE



TECHNICAL INFORMATION



TECHNISCHE EIGENSCHAFTEN

La Tabella 3 a fine paragrafo indica alcuni esempi di classificazione delle condizioni di carico.

La relazione II è verificata dalla formula:

Table 3 at the end of this section includes some examples of load classifications.

Relationship II can be verified by using the following formula:

Die Tabelle 3 am Abschnittsende zeigt einige Beispiele der Einstufung nach Einsatzbedingungen.

Die Relation II wird mit folgender Formel überprüft:

$$M_e \times f_s \leq M_c \times f_h$$

Si richiede inoltre che
 $M_p \leq M_{\max}$

M_p = coppia di picco in funzionamento

It is also required that
 $M_p \leq M_{\max}$

M_p = working peak torque

Bedingung ist daß
 $M_p \leq M_{\max}$

M_p = Spitzenmoment während des Betriebes

VERIFICA DEL RIDUTTORE IN FUNZIONE DEI CARICHI SULL'ALBERO DI USCITA E DI ENTRATA

Calcolo dei carichi equivalenti
Fre; Fae [N]

Analogamente a quanto fatto per il calcolo della coppia equivalente, quando il carico è variabile nel tempo, si deve determinare il valore del carico medio equivalente. Con il criterio del cumulativo di carico si determina, con la formula sotto indicata, il carico in grado di provocare lo stesso livello di usura sui cuscinetti dopo il numero di cicli (nxh) richiesto dal progetto:

VERIFICATION OF THE DRIVE ACCORDING TO OUTPUT SHAFT LOADS

Equivalent working loads
Fre; Fae [N]

In the same manner that we calculated the equivalent working torque, when loads vary over time, we must determine the value of the average equivalent load. As before, we use the cumulative load principle, based on the following formula, to determine the load value which produces the same fatigue on the bearings after the number of cycles (nxh) required by the project:

ÜBERPRÜFUNG DER GETRIEBEAUSWAHL NACH DER AUF DER ABTRIEBSWELLE WIRKENDEN BELASTUNGEN

Berechnung der equivalentbelastung
Fre; Fae [N]

Wie bereits bei der Berechnung des Drehmoments, soll man die equivalente Wellenbelastung ermitteln. Unter Berücksichtigung des Lastkollektivs wird mittels der unten angegebenen Damit wird die Haltbarkeit der Lagerung gewährleistet. Formel die resultierende Kraft Fe ermittelt:

$$F_e = \sqrt[10/3]{F_1^{10/3} \frac{(n_1 \times h_1)}{(n \times h)} + F_2^{10/3} \frac{(n_2 \times h_2)}{(n \times h)} + F_3^{10/3} \frac{(n_3 \times h_3)}{(n \times h)}}$$

Fattore di servizio f_s

Il fattore di servizio f_s si calcola con l'ausilio delle Tabelle 2 e 3 analogamente a quanto fatto per la coppia.

La relazione III è verificata dalle formule:

Service factor f_s

Service factor f_s can be calculated using Tables 2 and 3 in the same manner as calculating the torque.

Relationship III can be verified by using the following formulas:

Betriebsfaktor f_s

Den Betriebsfaktor f_s ermittelt man mit Hilfe der Tabelle 2 und 3 mit der gleichen Vorgehensweise wie bei der entsprechenden Momentenberechnung

Die Relation III wird mit folgender Formel überprüft:

$$F_r \times f_s \leq F_r \times f_h \\ F_{ae} \times f_s \leq F_a \times f_h$$

Le Tableau 3 en fin de chapitre fournit quelques exemples de classification des conditions de charge.

Le rapport II peut être vérifié par le biais de cette formule

La Tabla 3 que está en el final del párrafo indica algunos ejemplos de clasificación de las condiciones de carga.

La relación II se verifica con la fórmula:

A Tabela 3 no fim do parágrafo indica alguns exemplos de classificação das condições de carga.

A relação II é verificada pela fórmula:

$$M_e \times f_s \leq M_c \times f_h$$

Il est nécessaire que
 $M_p \leq M_{\max}$

M_p = couple de pic en fonctionnement

además se requiere que
 $M_p \leq M_{\max}$

M_p = momento de pico durante el funcionamiento

Também é necessário que
 $M_p \leq M_{\max}$

M_p = torque de pico de funcionamento

CONTRÔLE DU RÉDUCTEUR EN FONCTION DES CHARGES SUR L'ARBRE DE SORTIE ET D'ENTRÉE

Calcul des charges equivalentes
Fre; Fae [N]

De même que pour le calcul du couple équivalent, lorsque la charge varie dans le temps, il est nécessaire d'établir la valeur de la charge moyenne équivalente. Par l'intermédiaire du critère du cumul des charges est calculée, au moyen de la formule ci-dessous, la charge qui détermine le même niveau d'usure des roulements à l'issue du nombre de cycles (nxh) requis par le projet:

VERIFICACIÓN DEL REDUCTOR SEGÚN LAS CARGAS EN EL EJE DE SALIDA Y DE ENTRADA

Cálculo de las cargas equivalentes
Fre; Fae [N]

En modo análogo a como se calculó el momento equivalente, cuando la carga varía durante el tiempo, se tendrá que determinar el valor de la carga media equivalente. Como antes, se empleó el criterio de la carga acumulada y su valor se determina con la fórmula abajo indicada, la carga es capaz de ocasionar el mismo nivel de desgaste en los rodamientos después del número de ciclos (nxh) requerido por el proyecto:

VERIFICAÇÃO DO REDUTOR EM FUNÇÃO DAS CARGAS NO EIXO DE SAÍDA E DE ENTRADA

Cálculo das cargas equivalentes
Fre; Fae [N]

Analogamente às operações feitas para calcular o torque equivalente, quando a carga varia no tempo deve-se determinar o valor da carga média equivalente. Adotando o princípio da carga cumulativa determina-se, com a fórmula indicada abaixo, a carga que produz o mesmo nível de desgaste nos rolamentos após o número de ciclos (nxh) requerido pelo projeto:

$$F_e = \sqrt[10]{F_1^{10/3} \frac{(n_1 \times h_1)}{(n \times h)} + F_2^{10/3} \frac{(n_2 \times h_2)}{(n \times h)} + F_3^{10/3} \frac{(n_3 \times h_3)}{(n \times h)}}$$

Le facteur de service fs

Le facteur de service fs est calculé à l'aide des Tableaux 2 et 3 selon les mêmes principes que pour le couple.

Le rapport relation III peut être vérifié par les formules suivantes:

Factor de servicio fs

El factor de servicio fs se calcula con la ayuda de las Tablas 2 y 3 en modo análogo al cálculo del momento.

La relación III se verifica con las fórmulas:

Fator de serviço fs

Calcula-se o fator de serviço fs com o auxílio das Tabelas 2 e 3 de maneira análoga às operações feitas para o torque.

A relação III é verificada pelas fórmulas:

$$F_r \times f_s \leq F_r \times f_h$$

$$F_{ae} \times f_s \leq F_a \times f_h$$

CARICHI RADIALI Fr [N]

Questo capitolo vuole essere di supporto all'utilizzatore del catalogo per determinare il carico radiale massimo accettabile e/o la durata di vita dei cuscinetti degli alberi di entrata e uscita del riduttore selezionato.

Come determinare il carico radiale massimo ammissibile di un albero di entrata o di uscita conoscendo la durata di vita richiesta dei cuscinetti e la posizione del carico.

Parametri conosciuti:

- Versione del supporto
Entrata:
EL, EML, EM, EP, ET
Uscita:
MS, MC, PS, PC
- Distanza E [mm]
(Distanza del carico dallo spallamento dell'albero)
- Durata di vita richiesta dei cuscinetti [h]
- Velocità di rotazione dell'albero [min^{-1}]

Per determinare la capacità di carico radiale massimo ammissibile di un albero di entrata o di uscita, in base ai parametri conosciuti, seguire il seguente procedimento:

1. Selezionare il grafico della curva dei cuscinetti per l'albero di uscita o entrata selezionato. (I grafici relativi ai carichi applicabili in uscita sono riportati nelle sezioni dei dati tecnici di ogni riduttore, mentre quelli relativi agli alberi di entrata si trovano a pag. D-4).
2. Trovare nel grafico il valore del carico radiale (Fr) riferito alla distanza E.

RADIAL LOADS Fr [N]

This section provides the catalogue user with the information needed to determine the maximum allowable radial load and/or the service life of the bearings on input and output shafts of the selected drive.

How to determine the admissible radial load of an input or output shaft knowing the required service life of the bearings and the load position..

Known parameters:

- Input or output version
Input:
EL, EML, EM, EP, ET
Output:
MS, MC, PS, PC
- Distance E [mm]
(Distance of the load position from output shaft shoulder)
- Required bearing service life [h]
- Shaft rotation speed [min^{-1}]

To determine the admissible radial load capacity of a selected input or output shaft, based on known parameters, follow the steps described below:

1. Select the bearing service life chart for the selected input or output shaft (radial load curves for output shaft versions are shown on the drive technical sheets, while the curves for input versions can be found on pages D-4).
2. Use the curve to find the radial load (Fr) value with reference to the distance E.

RADIALLAST Fr [N]

Dieser Abschnitt soll dem Benutzer des Katalogs in den nachfolgenden Punkten Unterstützung bieten: die Feststellung der max. übertragbaren Radiallast und/oder der Lebensdauer der Lagerungen an Anund Abtriebswelle der gewünschten Getriebeausführung.

Wie wird die Radiallast einer Vollwelle in An- oder Abtrieb festgestellt, wenn die geforderte Lebensdauer der Lager und der Eingriffspunkt der Last bekannt sind.

Bekannte Parameter:

- Ausführung
Antriebswelle:
EL, EML, EM, EP, ET
Abtriebswelle:
MS, MC, PS, PC
- Abstand E [mm]
(Abstand des Lasteingriffspunktes vom Wellenansatz)
- Geforderte Lebensdauer der Lager [h]
- Drehgeschwindigkeit [min^{-1}]

Um die Radiallast der An- oder Abtriebswelle auf der Basis der vorgenannten, bekannten Parameter zu bestimmen, ist jetzt gemäß dem folgenden Ablauf vorzugehen:

1. Auswählen der entsprechenden Grafik (Lebensdauer der Lager an An-oder Abtriebswelle) gemäß gewünschter Ausführung. Die entsprechenden Diagramme der übertragbaren Radiallast im Abtrieb sind in den modellspezifischen Datenblättern ersichtlich, dagegen sind die Diagramme bezüglich des Antriebs auf den Seiten D-4 zu finden.
2. Den Radiallast-Wert (Fr) feststellen, der mit dem vorgegebenen Abstand X korrespondiert.

Esempio di diagramma della curva dei cuscinetti dei supporti di entrata e uscita.

Example of bearing service life curve for input and/or output shaft versions. Grafisches Beispiel einer Kurve der Lagerung im Antrieb/Abtrieb.

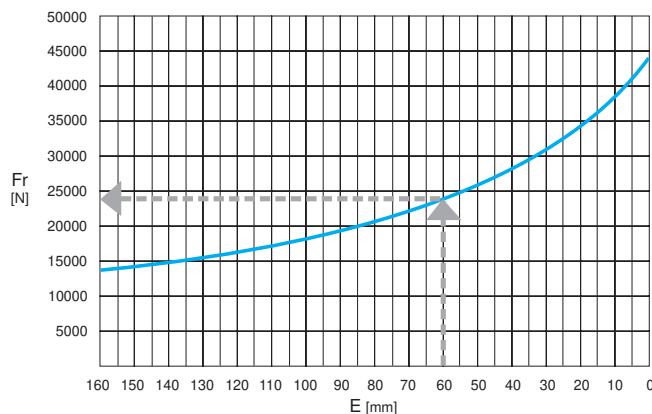

CHARGES RADIALES Fr [N]

Le présent chapitre a pour but de fournir une aide à l'utilisateur du catalogue pour déterminer la charge radiale maximum admissible et/ou la durée de vie des roulements des arbres d'entrée et sortie du réducteur sélectionné.

Comment déterminer la charge radiale maximum acceptable d'un arbre d'entrée ou de sortie en connaissant la durée de vie requise des roulements et la position de la charge.

Paramètres connus:

- Version du support
 - Entrée: EL, EML, EM, EP, ET
 - Sortie MS, MC, PS, PC
- Distance E [mm] (distance entre la charge et la base de l'arbre)
- Durée de vie requise des roulements [h]
- Vitesse de rotation de l'arbre [min^{-1}]

Pour déterminer la capacité de charge radiale maximum admissible d'un arbre d'entrée ou de sortie, en fonction des paramètres connus, procéder comme suit:

1. Sélectionner le graphique de la courbe des roulements pour l'arbre de sortie ou d'entrée sélectionné (les graphiques relatifs aux charges applicables en sortie figurent dans les sections des données techniques de chaque réducteur, alors que ceux relatifs aux arbres d'entrée se trouvent pages D-4).
2. Trouver sur le graphique, la valeur de la charge radiale (Fr) en fonction de la distance E.

CARGAS RADIALES Fr [N]

Este capítulo sirve para ayudar al usuario del catálogo a determinar la carga radial máxima aceptable y/o el tiempo de vida de los rodamientos de los ejes de entrada y salida del reductor seleccionado.

Cómo determinar la carga radial máxima admisible de un eje de entrada o de salida conociendo el tiempo de vida requerido por los rodamientos y la posición de la carga.

Parámetros conocidos:

- Tipo de soporte
 - Entrada: EL, EML, EM, EP, ET
 - Salida: MS, MC, PS, PC
- Distancia E [mm] (Distancia entre la carga y la base del eje)
- Tiempo de vida requerido de los rodamientos [h]
- Velocidad de rotación del eje [min^{-1}]

Para determinar la capacidad admisible de carga radial de un eje de entrada o de salida, en base a los parámetros conocidos, seguir el siguiente procedimiento:

1. Seleccionar el gráfico de la curva de los rodamientos para el eje de salida o entrada seleccionado. (Los gráficos de las cargas aplicables en los ejes de salida se indican en las secciones de los datos técnicos de cada reductor, mientras que los gráficos de los ejes de entrada se encuentran en la Pág. D-4).
2. Encontrar en el gráfico el valor de la carga radial (Fr) referida a la distancia E.

CARGAS RADIAIS Fr [N]

A finalidade deste capítulo é a de fornecer um auxílio ao usuário do catálogo para determinar a carga radial máxima aceitável e/ou a vida útil dos rolamentos dos eixos de entrada e de saída do reductor selecionado.

Como determinar a carga radial máxima admissível de um eixo de entrada ou de saída conhecendo a vida útil requerida dos rolamentos e a posição da carga.

Parâmetros conhecidos

- Versão do suporte
 - Entrada: EL, EML, EM, EP, ET
 - Saída: MS, MC, PS, PC
- Distância E [mm] (Distância entre a carga e a base do eixo)
- Vida útil requerida dos rolamentos [h]
- Velocidade de rotação do eixo [min^{-1}]

Para determinar a capacidade de carga radial máxima admissível de um eixo de entrada ou de saída, com base nos parâmetros conhecidos, siga este procedimento:

1. Selecione o gráfico da curva dos rolamentos para o eixo de saída ou de entrada selecionado. (Os gráficos das cargas aplicáveis na saída estão reproduzidos nas seções de dados técnicos de cada reductor, enquanto que os gráficos dos eixos de entrada estão reproduzidos nas págs. D-4).
2. Localize no gráfico o valor da carga radial (Fr) referida à distância E.

Exemple de diagramme de la courbe des roulements des supports d'entrée et de sortie

Ejemplo de diagrama de la curva de los rodamientos de los soportes de entrada y salida.

Exemplo de diagrama da curva dos rolamentos dos suportes de entrada e saída

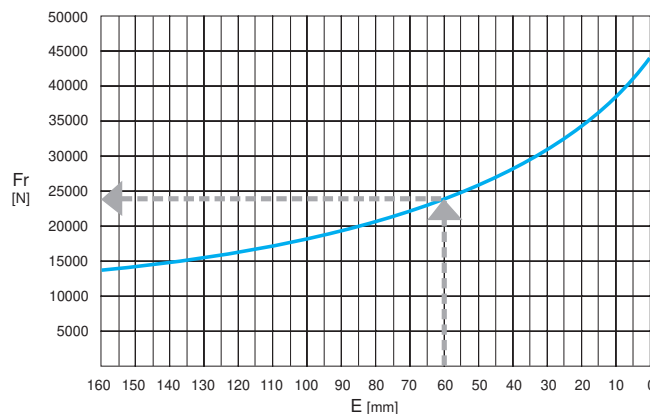



CARATTERISTICHE TECNICHE



TECHNICAL INFORMATION



TECHNISCHE EIGENSCHAFTEN

3. Il valore di Fr trovato è il valore di carico radiale massimo accettabile nella posizione E per una durata di vita dei cuscinetti h di:

3. Fr will be the max. load the shaft can bear at position E for a bearing service life h of:

3. Der festgestellte Wert (Fr) ist die max. tragbare Radiallast in Verbindung zum Abstand E bei einer Lebensdauer der Lager h von:

Albero di uscita

Output version

Abtriebswelle

$$h = \frac{10^5}{n_2}$$

Albero di entrata

Input version

Antriebswelle

$$h = \frac{5 \times 10^6}{n_1}$$

h = Durata di vita dei cuscinetti [h]
 n₁ = Velocità di rotazione dell'albero entrata [min⁻¹]
 n₂ = Velocità di rotazione dell'albero uscita [min⁻¹]

h = Bearings life time [h]
 n₁ = Input shaft speed [min⁻¹]
 n₂ = Output shaft speed [min⁻¹]

h = Lebensdauer der Lager [h]
 n₁ = Drehgeschwindigkeit der Antriebswelle [min⁻¹]
 n₂ = Drehgeschwindigkeit der Abtriebswelle [min⁻¹]

Nel caso la durata di vita dei cuscinetti, calcolata con le suddette formule, non corrisponda a quella richiesta occorrerà determinare il coefficiente di correzione del carico radiale per ottenere la durata richiesta seguendo il seguente procedimento:

If the bearing service life, as calculated with the previous formulas, does not meet customer requirements, the radial load correction factor that would allow the bearings to meet the service life requirements must be determined according to the following procedure:

Für den Fall, dass die so kalkulierte Lebensdauer nicht mit der geforderten Lebensdauer übereinstimmt, wird der Korrekturkoeffizient K der Radiallast eingesetzt. Dieses wird mit dem nachfolgenden Ablauf erreicht:

4. Determinare il numero di cicli che l'albero compierà durante la durata di vita richiesta:
 nxh = n₁₋₂ [min⁻¹] x h [h].

4. Determine the no. of cycles that the shaft will complete during the required service life:
 nxh = n₁₋₂ [min⁻¹] x h [h]

4. Bestimmung von Anzahl der Zyklen über die geforderte Lebensdauer der Lager:

$$nxh = n_{1-2} [\text{min}^{-1}] \times h [\text{h}]$$

5. Determinare, nel grafico del coefficiente di correzione del carico radiale, il valore K corrispondente al numero di cicli calcolati al punto 1.
 (I grafici relativi ai coefficienti di correzione riferiti ai carichi applicabili in uscita sono riportati nelle sezioni dei dati tecnici di ogni riduttore, mentre quelli relativi agli alberi di entrata si trovano a pag. D-4).

5. Use the radial load correction factor curve to determine the K value corresponding to the no. of cycles calculated in point 1.
 (radial load correction factor curves for output shaft versions are shown on the drive technical sheets, while the curves for input versions can be found on pages D-4).

5. Feststellen des Korrekturkoeffizienten (K) der Radiallast in der entsprechenden Grafik - korrespondierend mit dem Punkt 1.
 Die entsprechenden Diagramme des Korrekturkoeffizienten im Bezug auf die tragbare Radiallast im Abtrieb sind in den modellspezifischen Datenblaettern ersichtlich, dagegen sind die Diagramme bezueglich des Antriebs auf den Seiten D-4 zu finden.

Esempio di diagramma del coefficiente di correzione del carico radiale.
 Example of radial load correction factor curve for input and/or output shaft versions
 Grafisches Beispiel des Korrekturkoeffizienten der Radiallast

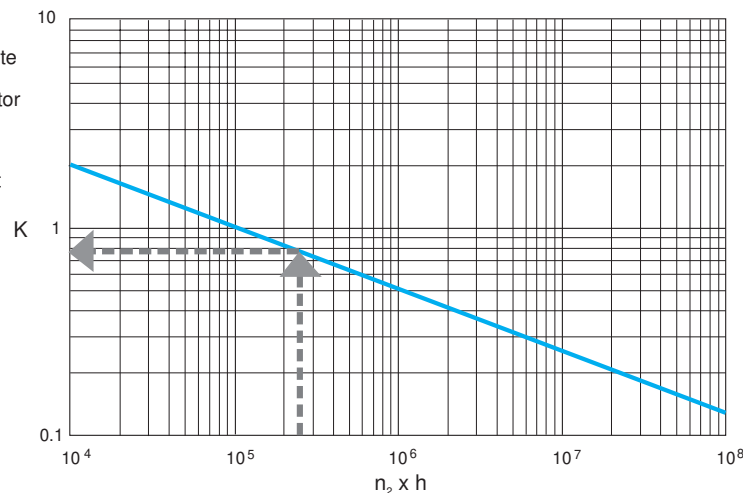

3. La valeur F_r trouvée est la valeur de charge radiale maximum acceptable dans la position E pour une durée de vie des roulements h de:

3. El valor obtenido de F_r es el valor máximo de carga radial aceptable en la posición E para un tiempo de vida de los rodamientos h de:

3. O valor de F_r encontrado é o valor de carga radial máxima aceitável na posição E para uma vida útil dos rolamentos h de:

Arbre de sortie

Eje de salida

Eixo de saída

$$h = \frac{10^5}{n_2}$$

Arbre d'entrée

Eje de entrada

Eixo de entrada

$$h = \frac{5 \times 10^6}{n_1}$$

h = durée de vie des roulements (h)
 n_1 = vitesse de rotation l'arbre d'entrée [min^{-1}]
 n_2 = vitesse de rotation de l'arbre de sortie [min^{-1}]

h = Tiempo de vida útil de los rodamientos (h)
 n_1 = Velocidad de rotación del eje de entrada [min^{-1}]
 n_2 = Velocidad de rotación del eje de salida [min^{-1}]

h = Vida útil dos rolamentos (h)
 n_1 = Velocidade de rotação do eixo de entrada [min^{-1}]
 n_2 = Velocidade de rotação do eixo de saída [min^{-1}]

Si la durée de vie des roulements, calculée par le biais des formules indiquées plus haut, ne correspond pas à celle requise, il est nécessaire de déterminer le coefficient de correction de la charge radiale pour obtenir la durée requise en procédant comme suit:

Si el tiempo de vida de los rodamientos, calculado con las respectivas fórmulas, no correspondiera al solicitado será necesario determinar el coeficiente de corrección de la carga radial para obtener la duración requerida de los rodamientos siguiendo el siguiente procedimiento:

Se a vida útil dos rolamentos, calculada com as fórmulas acima indicadas, não coincidir com a requerida, será preciso determinar o coeficiente de correção da carga radial para obter a vida útil requerida adotando este procedimento:

- Établir le nombre de cycles accomplis par l'arbre pendant la durée de vie requise:
 $n_x h = n_{1-2} [\text{min}^{-1}] \times h [\text{h}]$
- Établir, à l'aide du graphique du coefficient de correction de la charge radiale, la valeur K correspondant au nombre de cycles calculé au point 1 (les graphiques relatifs aux coefficients de correction des charges applicables en sortie figurent dans les sections des données techniques de chaque réducteur, tandis que ceux relatifs aux arbres d'entrée se trouvent pages D-4).

- Determinar el número de ciclos que efectuará el eje durante el tiempo de vida requerido:
 $n_x h = n_{1-2} [\text{min}^{-1}] \times h [\text{h}]$
- Determinar, en el gráfico del coeficiente de corrección de la carga radial, el valor K correspondiente al número de ciclos calculado en el punto 1. (Los gráficos de los coeficientes de corrección para las cargas aplicadas en los ejes de salida se indican en las secciones de los datos técnicos de cada reductor, mientras que los datos de los ejes de entrada se encuentran en la Pág. D-4).

- Determine o número de ciclos que o eixo irá realizar durante a vida útil requerida:
 $n_x h = n_{1-2} [\text{min}^{-1}] \times h [\text{h}]$
- No gráfico do coeficiente de correção da carga radial, determine o valor K correspondente ao número de ciclos calculado no ponto 1. (Os gráficos dos coeficientes de correção referidos às cargas aplicáveis na saída estão reproduzidos nas seções de dados técnicos de cada reductor, enquanto que os gráficos dos eixos de entrada estão reproduzidos nas págs. D-4).

Exemple de diagramme du coefficient de correction de la charge radiale.
Ejemplo de diagrama del coeficiente de corrección de la carga radial.
Exemplo de diagrama do coeficiente de correção da carga radial.

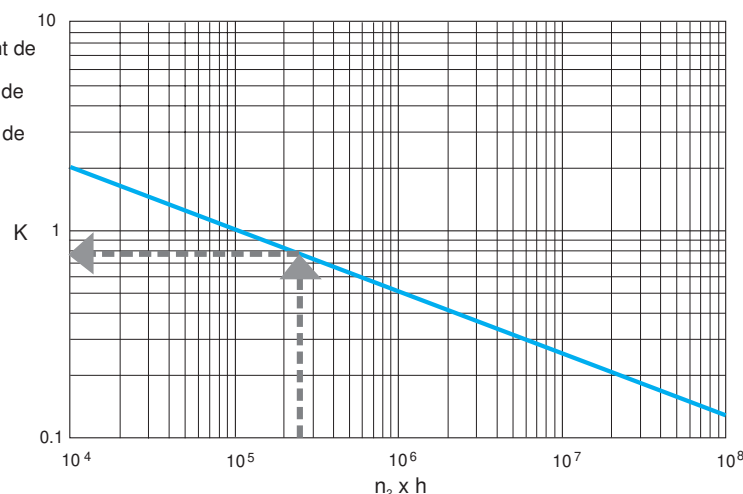

6. Ora potrete definire quale sarà il carico massimo accettabile $F_{r_{nxh}}$ nella posizione E che garantirà la durata di vita dei cuscinetti richiesta applicando la seguente formula:

6. Now you can determine the acceptable radial load $F_{r_{nxh}}$ at the known position E to meet the bearing service life requirements, applying the following formula:

6. Jetzt kann einwandfrei bestimmt werden, welche Radiallast $F_{r_{nxh}}$ (auf der Basis des vorgegebenen Abstands E) annehmbar ist, um die geforderte Lebensdauer der Lager garantieren zu können:

$$F_{r_{nxh}} = F_r \times K$$

Come determinare la durata di vita richiesta dei cuscinetti di un albero di entrata o di uscita conoscendo il carico radiale applicato e la posizione del carico.

Parametri conosciuti:

- Versione del supporto
Entrata:
EL, EML, EM, EP, ET
Uscita:
MS, MC, PS, PC
- Distanza E [mm]
(Distanza del carico dallo spallamento dell'albero)
- Carico radiale applicato [kN]
- Velocità di rotazione dell'albero [min-1]

Per determinare la durata di vita dell'albero di entrata o di uscita scelto, in base ai parametri conosciuti, seguire il seguente procedimento:

1. Selezionare il grafico della durata di vita dei cuscinetti dell'albero di entrata o uscita selezionato.
2. Individuare nel grafico il carico radiale (F_r) riferito alla posizione del carico E.
3. Determinare il fattore di correzione del carico radiale K applicando la seguente formula:

How to determine the bearing service life of an input or output shaft version knowing the applied radial load and its load position.

Known parameters:

- Input or output version
Input:
EL, EML, EM, EP, ET
Output:
MS, MC, PS, PC
- Load position E [mm]
(Distance of the load from the output shaft shoulder)
- Applied radial load [kN]
- Shaft speed [min-1]

To determine the bearing service life of the selected input or output shaft, based on known parameters, follow the steps described below:

1. Select the service life curve of the bearings for the selected input or output shaft.
2. Use the chart to find the radial load (F_r) with reference to the load position E.
3. Determine the radial load correction factor K applying the following formula:

$$K = \frac{F_{r_{ap}}}{F_r}$$

$F_{r_{ap}}$ = Carico radiale applicato [kN]

4. Una volta determinato il fattore K individuare sul grafico del fattore di correzione del carico radiale il valore di nxh corrispondente.

5. Infine per determinare la durata di vita dei cuscinetti riferito al carico radiale applicato ed alla sua posizione E applicare la seguente formula:

$F_{r_{ap}}$ = Applied radial load [kN]

4. Once you have determined the K factor, use the radial load correction factor curve to find the corresponding (nxh) value.

5. Finally, to determine the bearing service life based on the applied radial load and its position E, apply the following formula:

Bekannte Parameter:

- Ausführung
Antriebswelle:
EL, EML, EM, EP, ET
Abtriebswelle:
MS, MC, PS, PC
- Abstand E [mm]
(Abstand des Lasteingriffspunktes vom Wellenansatz)
- Applizierte Radiallast [kN]
- Drehgeschwindigkeit [min-1]

Um die Lebensdauer der Lager der Anoder Abtriebswelle auf der Basis der vorgenannten, bekannten Parameter zu bestimmen, ist jetzt gemäss dem folgenden Ablauf vorzugehen:

1. Auswählen der entsprechenden Grafik (Lebensdauer dem Lager an Anoder Abtriebswelle) gemäss gewünschter Ausführung.
2. Den Radiallast-Wert (F_r) feststellen, der mit dem vorgegebenen Abstand E korrespondiert.
3. Den Korrekturkoeffizienten K der Radiallast nach der folgenden Formel bestimmen:

$F_{r_{ap}}$ = applizierte Radiallast [kN]

4. Den ermittelten Koeffizienten K der Radiallast in der entsprechenden Darstellung mit dem korrespondierenden Wert nxh in Verbindung setzen.

5. Jetzt kann einwandfrei bestimmt werden, welche Lebensdauer der Lager in Verbindung zur vorgegebenen Radiallast (auf der Basis des vorgegebenen Abstands E) annehmbar ist. Dazu ist die nachfolgende Formel einzusetzen:

$$h = \frac{n \times h}{n_{1-2}}$$

6. Il est à présent possible de définir la charge maximum acceptable $F_{r_{nxh}}$ dans la position E connue qui garantira la durée de vie requise des roulements, en appliquant la formule suivante:

6. Ahora se podrá definir cuál será la carga máxima aceptable $F_{r_{nxh}}$ en la posición E que podrá garantizar el tiempo de vida requerido de los rodamientos, aplicando la siguiente fórmula:

6. Agora poderá definir qual será a carga máxima aceitável $F_{r_{nxh}}$ na posição E que irá garantir a vida útil requerida para os rolamentos aplicando a seguinte fórmula:

$$F_{r_{nxh}} = F_r \times K$$

Comment déterminer la durée de vie requise des roulements d'une d'arbre d'entrée ou de sortie en connaissant la charge radiale appliquée et sa position.

Cómo determinar el tiempo de vida útil requerido de los rodamientos de un eje de entrada o de salida conociendo la carga radial aplicada y la posición de la carga.

Como determinar a vida útil requerida dos rolamentos de um eixo de entrada ou de saída conhecendo a carga radial aplicada e a posição da carga.

Paramètres connus:

- Version du support:
Entrée:
EL, EML, EM, EP, ET
Sortie:
MS, MC, PS, PC
- Distance E [mm]
(distance entre la charge et la base de l'arbre)
- Charge radiale appliquée [kN]
- Vitesse de rotation l'arbre [min-1]

Parámetros conocidos:

- Versión del soporte
Entrada:
EL, EML, EM, EP, ET
Salida:
MS, MC, PS, PC
- Distancia E [mm]
(Distancia entre la carga y la base del eje)
- Carga radial aplicada [kN]
- Velocidad de rotación del eje [min-1]

Parâmetros conhecidos:

- Versão do suporte
Entrada:
EL, EML, EM, EP, ET
Saída:
MS, MC, PS, PC
- Distância E [mm]
(Distância entre a carga e a base do eixo)
- Carga radial aplicada [kN]
- Velocidade de rotação do eixo [min-1]

Pour déterminer la durée de vie de l'arbre d'entrée ou de sortie choisi, en fonction des paramètres connus, procéder comme suit:

Para determinar el tiempo de vida útil del eje de entrada o de salida elegido, en base a los parámetros conocidos, seguir el siguiente procedimiento:

Para determinar a vida útil do eixo de entrada ou de saída escolhido, com base nos parâmetros conhecidos, siga este procedimento:

1. Sélectionner le graphique de la durée de vie des roulements de l'arbre d'entrée ou de sortie sélectionné.
2. Trouver dans le graphique la charge radiale (F_r) correspondant à la position de la charge E.
3. Déterminer le facteur de correction de la charge radiale K en appliquant la formule suivante:

1. Seleccionar el gráfico del tiempo de vida útil de los rodamientos del eje de entrada o de salida seleccionado.
2. Localizar en el gráfico la carga radial (F_r) correspondiente a la posición de la carga E.
3. Determinar el factor de corrección de la carga radial K aplicando la siguiente fórmula:

1. Selecione o gráfico de vida útil dos rolamentos do eixo de entrada ou de saída selecionado.
2. Localize no gráfico a carga radial (F_r) referida à posição da carga E.
3. Tendo determinado o fator K, localize no gráfico do fator de correção da carga radial o valor de n_{xh} correspondente.

$$K = \frac{F_{r_{ap}}}{F_r}$$

$F_{r_{ap}}$ = Charge radiale appliquée [kN]

$F_{r_{ap}}$ = Carga radial aplicada [kN]

$F_{r_{ap}}$ = Carga radial aplicada [kN]

4. Une fois établi le facteur K; trouver dans le graphique du facteur de correction de la charge radiale, la valeur de n_{xh} correspondante.
5. Établir enfin la durée de vie des roulements en fonction de la charge radiale appliquée et de sa position E, et appliquer la formule suivante:

4. Después de determinar el factor K localizar en el gráfico del factor de corrección de la carga radial el correspondiente valor de n_{xh} .
5. Por último, determinar el tiempo de vida útil de los rodamientos basándose en la carga radial aplicada y a su posición E utilizando la siguiente fórmula:

4. Tendo determinado o fator K, localize no gráfico do fator de correção da carga radial o valor de n_{xh} correspondente.
5. Por fim, para determinar a vida útil dos rolamentos referida à carga radial aplicada e à sua posição E, aplique a seguinte fórmula:

$$h = \frac{n \times h}{n_{1-2}}$$

Il carico radiale Fr_a agente sull'albero del riduttore può essere calcolato con le seguenti formule secondo il tipo di trasmissione adottato.

The Fr_a radial load on the drive's shaft can be calculated with the following formulas according to the type of transmission used.

Die auf die Getriebewelle einwirkende Radiallast Fr_a kann je nach angewandtem Getriebetyp mit folgenden Formeln berechnet werden.

Giunto elastico
Elastic coupling
Elastische Kupplung

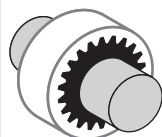

No carico radiale
No radial load
Keine Radiallast

Ingranaggi a denti dritti (angolo pressione 20°)
Spur gear (pressure angle 20°)
Zahnräder mit gerader Verzahnung (Druckwinkel 20°)

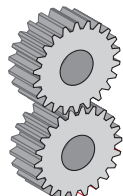

$$Fr_a = \frac{2100 \cdot M_2}{D}$$

Catene a bassa velocità ($z < 17$)
Chain drives at low speed ($z < 17$)
Kettengeräte mit niedriger Geschwindigkeit ($z < 17$)

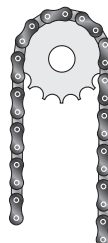

$$Fr_a = \frac{2100 \cdot M_2}{D}$$

Pullegge dentate
Trigger belt
Zahnriemen

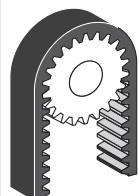

$$Fr_a = \frac{2100 \cdot M_2}{D}$$

Pullegge a gole V
Pulley for V belt
Keilriemen

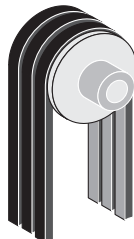

$$Fr_a = \frac{4000 \cdot M_2}{D}$$

Cinghia piana con tenditore
Flat belt with spanning pulley
Flachriemen mit spanner

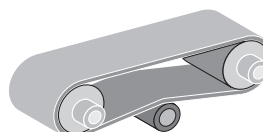

$$Fr_a = \frac{8000 \cdot M_2}{D}$$

Fr_a = Carico radiale risultante sull'albero [N]
 M_2 = Momento torcente sull'albero [Nm]
 D = Diametro primitivo ingranaggio o puleggia [mm]

Fr_a = Radial load on shaft [N]
 M_2 = Torque on shaft [Nm]
 D = Gear or pulley pitch diameter [mm]

Fr_a = Radiallast an der Welle [N]
 M_2 = Drehmoment an der Welle [Nm]
 D = Teilkreisdurchmesser des Zahnrads oder der Riemenscheibe [mm]

VERIFICA DEL RIDUTTORE IN FUNZIONE DELLA POTENZA TERMICA
Pt [kW]

Nel caso in cui il riduttore sia utilizzato a velocità di uscita superiore a 20 min^{-1} ed in servizio continuo, o comunque abbia soste tra una inserzione e l'altra tali da non consentire il normale smaltimento del calore, è necessario verificare che la potenza effettivamente trasmessa non superi quella indicata nella scheda tecnica relativa al singolo tipo di riduttore.

Per i riduttori di grosse dimensioni vi possono essere limitazioni alla velocità max in entrata, di cui si deve tenere conto e che sono indicate sempre nella scheda tecnica del prodotto.

VERIFICATION OF THE DRIVE ACCORDING TO THE THERMAL POWER
Pt [kW]

When the drive is used with an output speed greater than 20 min^{-1} under continuous duty or with stops between applications that inhibit normal heat dissipation, make sure that the actual transmitted power does not exceed the power indicated on the data sheet of the individual drive.

For large drives, the maximum input speeds, as always shown on the product's data sheet, must be taken into account.

ÜBERPRÜFUNG DES GETRIEBES AUFGRUND DER THERMISCHEN LEISTUNG
Pt [kW]

Wird das Getriebe im Dauerbetrieb bei Raumtemperatur und mit einer Abtriebsdrehzahl von über 20 min^{-1} ein gesetzt bzw. mit Unterbrechungen zwischen den Einschaltungen, die zu kurz sind, um die normale Wärmeableitung zu gewährleisten, muss kontrolliert werden, dass die tatsächlich übertragene Leistung nicht den Wert überschreitet, der in den jeweiligen Getriebetypen zugeordneten technischen Datenblättern verzeichnet ist.

Bei großen Getrieben können zulässige Höchstwerte für die Eingangsgeschwindigkeit vorgeschrieben sein, die generell im technischen Datenblatt des Produkts aufgeführt sind und eingehalten werden müssen.

Le informazioni tecniche contenute nel presente catalogo intendono essere una rapida guida alla scelta dei riduttori e non vogliono in nessun caso sostituirsi alle conoscenze ed all'esperienza dei tecnici impiantisti cui spetta il compito di determinare i riduttori da installare.

Nello spirito della migliore collaborazione con i clienti, la Comer Industries S.p.A. è lieta di mettere a disposizione il proprio servizio tecnico per le verifiche che si rendono necessarie.

The technical information in this catalog is provided as a brief guide for selecting drives and does not substitute the knowledge and experience of the installers who are responsible for selecting the proper drive.

To collaborate as much as possible with its customers, Comer Industries S.p.A. is pleased to offer the services of its technical assistance department to carry out any necessary verifications.

Die im Katalog enthaltenen technischen Informationen sollen eine Hilfe zur möglichst einfachen Auswahl der Getriebe sein. Diese Informationen sollen auf keinen Fall die Kenntnisse und die Erfahrung der Anlagentechniker ersetzen, die zu bestimmen haben, welcher Getriebetyp installiert werden muss.

Für eine optimale Zusammenarbeit steht der Kundenservice von Comer Industries S.p.A. Ihnen für jegliche Überprüfung und Beantwortung sonstiger technischer Fragen zur Verfügung.

La charge radiale Fr_a qui agit sur l'arbre du réducteur peut être calculée par le biais des formules ci-dessous selon le type de transmission adopté.

Joint élastique
Unión elástica
Acoplamento flexível

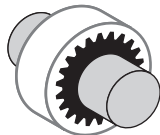

Aucune charge radiale
No carga radial
Sem carga radial

La carga radial Fr_a que actúa sobre el eje del reductor se puede calcular con las siguientes fórmulas según el tipo de transmisión utilizado.

Engrenages à dents droites (angle pression 20°)
Engranajes de dientes rectos (ángulo presión 20°)
Engrenagens de dentes retos (ângulo de pressão 20°)

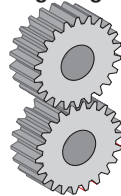

$$Fr_a = \frac{2100 \cdot M_2}{D}$$

A carga radial Fr_a que atua no eixo do reductor pode ser calculada com as seguintes fórmulas, em função do tipo de transmissão adotado.

Pour réducteur à chaîne à basse vitesse ($z < 17$)
Para reductor cadena a baja velocidad ($z < 17$)
Para reductor de corrente com baixa ($z < 17$)

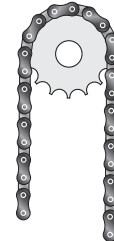

$$Fr_a = \frac{2100 \cdot M_2}{D}$$

Pour courroie dentée
Para correa dentada
Para correia dentada

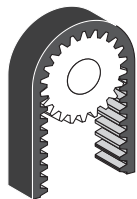

$$Fr_a = \frac{2100 \cdot M_2}{D}$$

Pour courroie trapézoïdale
Para correa trapezoidal
Para correia trapezoidal

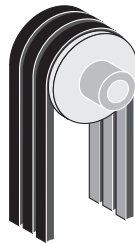

$$Fr_a = \frac{4000 \cdot M_2}{D}$$

Courroie plate avec tendeur
Correa plana con tensor
Correia plana com esticador

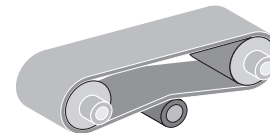

$$Fr_a = \frac{8000 \cdot M_2}{D}$$

Fr_a = Charge radiale exercée sur l'arbre [N]
 M_2 = Moment de torsion sur l'arbre [Nm]
D = Diamètre primitif engrenage ou poulie [mm]

Fr_a = Carga radial resultante sobre el eje [N]
 M_2 = Momento de torsión sobre el eje [Nm]
D = Diámetro primitivo engranaje o polea [mm]

Fr_a = Carga radial resultante no eixo [N]
 M_2 = Momento de torção no eixo [Nm]
D = Diâmetro primitivo da engrenagem ou polia [mm]

CONTRÔLE DU RÉDUCTEUR EN FONCTION DE LA PUISSANCE THERMIQUE Pt [kW]

Dans le cas où le réducteur serait utilisé à une vitesse de sortie supérieure à 20 min^{-1} et en service continu, ou bien que les arrêts de fonctionnement entre un enclenchement et l'autre ne seraient pas suffisamment longs pour permettre la dissipation normale de la chaleur, il est nécessaire de s'assurer que la puissance effectivement transmise ne dépasse pas celle indiquée sur la fiche technique du réducteur. En ce qui concerne les réducteurs de grandes dimensions, peuvent exister des limitations à la vitesse maximum en entrée, limitations dont il est nécessaire de tenir compte et qui sont indiquées sur la fiche technique du produit.

VERIFICACIÓN DEL REDUCTOR SEGÚN LA POTENCIA TÉRMICA Pt [kW]

Cuando se utilice el reductor con una velocidad de salida superior a 20 min^{-1} y con servicio continuo o de todas maneras con paradas entre una activación y otra tales que no permitan una disipación normal del calor, será necesario comprobar que la potencia efectivamente transmitida no supere aquella indicada en la respectiva ficha técnica del reductor. Para los reductores de grandes dimensiones puede haber unas limitaciones de la velocidad máx. de entrada, habrá que tener en cuenta dichas limitaciones que siempre vienen indicadas en la ficha técnica del producto.

VERIFICAÇÃO DO REDUTOR EM FUNÇÃO DA POTÊNCIA TÉRMICA Pt [kW]

Se o reductor for utilizado com uma velocidade de saída maior do que 20 min^{-1} e em serviço contínuo ou se funcionar com paradas entre duas ativações consecutivas que não permitam a dissipação normal do calor, será necessário verificar se a potência efetivamente transmitida não ultrapassa a indicada na ficha técnica do tipo de reductor em questão. Para os reductores de grandes dimensões, podem existir limitações para a velocidade máxima de entrada. Estas limitações devem ser levadas em conta e são sempre indicadas na ficha técnica do produto.

Les informations techniques figurant dans le présent catalogue constituent une aide dans le choix des réducteurs et ne sauraient se substituer aux connaissances ni à l'expérience des techniciens d'installation auxquels ils incombe d'établir le type de réducteur à installer.

Dans une optique de collaboration efficace avec les clients, Comer Industries S.p.A. met à la disposition de ceux-ci ses propres services techniques pour tout contrôle éventuellement nécessaire.

Las informaciones técnicas contenidas en este catálogo sirven como guía rápida para la elección de los reductores y en ningún caso se proponen sustituir los conocimientos y la experiencia de los técnicos en instalaciones que tienen la tarea de seleccionar los reductores a instalar.

Queriendo siempre colaborar con los clientes, Comer Industries S.p.A. pone con mucho gusto a disposición su propio Servicio Técnico para efectuar las comprobaciones que fueran necesarias.

As informações técnicas contidas neste catálogo são fornecidas com o intuito de auxiliar o usuário na escolha dos reductores e com elas não se pretende, de nenhuma maneira, substituir os conhecimentos e a experiência dos técnicos de instalação responsáveis por determinar os reductores que devem ser instalados.

Na óptica da melhor colaboração com os clientes, a Comer Industries S.p.A. põe à sua disposição o próprio serviço técnico para realizar as averiguações que se tornem necessária.



CONDIZIONI DI CARICO

Le condizioni di carico qui elencate possono subire variazioni in funzione delle reali condizioni di funzionamento dei riduttori.

Legenda:

U = Carico uniforme
M = Carico moderato
H = Carico pesante

LOAD CLASSIFICATION

Listed load conditions may change depending on drive actual operating conditions.

Legend:

U = Uniform load
M = Moderate load
H = Heavy load

BELASTUNGSKENNWERT

Die Änderung des erforderlichen Belastungskennwertes kann ggf. nach Angabe der genauen Betriebsbedingungen erfolgen.

Legende:

U = gleichmäßige Belastung
M = mittlere Belastung
H = schwere Belastung

Tabella 3 / Table 3 / Tabelle 3

Compressori, ventilatori	Blowers, ventilators	Gebälse, Förderer			
Compressori (assiali e radiali)	Blowers (axial and radial)	Gebälse	U		
Ventilatori a torre di raffreddamento	Cooling tower fans	Kühlturnlüfter		M	
Ventilatori a tiraggio indotto	Induced draught fans	Saugzuggebläse		M	
Compressori a pistoni rotanti	Rotary piston blowers	Drehkolbengebläse		M	
Compressoriturbo	Turbo blowers	Turbogebälse	U		
Industria chimica					
Agitatori (materiali liquidi)	Agitators (liquid material)	Rührwerke (leichte Flüssigkeit)	U		
Agitatori (materiali semi-liquidi)	Agitators (semi-liquid material)	Rührwerke		M	
Centrifughe (pesanti)	Centrifuges (heavy)	Zentrifugen (schwer)		M	
Centrifughe (leggere)	Centrifuges (light)	Zentrifugen (leicht)	U		
Tamburi di raffreddamento	Cooling drums	Kühltrommel		M	
Tamburi di essiccazione	Drying drums	Trockentrommel		M	
Miscelatori	Mixers	Mischer		M	
Compressori					
Compressori a pistone	Piston compressors	Kolbenkompressoren			H
Compressori turbo	Turbo compressors	Turbokompressoren		M	
Convogliatori					
Nastro trasportatore a piastre	Apron conveyors	Plattenbänder		M	
Sollevatori zavorra	Ballast elevators	Hebewerk		M	
Convogliatori nastro a sacca	Band pocket conveyors	Gurtaschenbecherwerke		M	
Convogliatori a nastro (materie voluminose)	Belt conveyors (bulk material)	Fördermaschinen (Schüttgut)		M	
Convogliatori (merce a pezzi)	Belt conveyors (piece goods)	Fördermaschinen (Stückgut)			H
Convogliatori a tazza per farinacei	Bucket conveyors for flour	Mehlbecherwerke	U		
Convogliatori a catena	Chain conveyors	Kettenfoerderanlagen		M	
Convogliatori circolari	Circular conveyors	Kreisförderer		M	
Montacarichi	Hoists	Lastaufzüge			H
Montacarichi inclinati	Inclined hoists	Schrägaufzüge			H
Convogliatore a nastro d'acciaio	Steel belt conveyors	Stahlbandförderer		M	
Sollevatori per persone	Passenger lifts	Personenaufzüge		M	
Trasportatori a coclea	Screw conveyors	Schneckenförderer		M	
Trasportatore a nastro concavo	Trough chain conveyors	Trogkettenförderer		M	
Trasportatore a verricello	Winches hauling	Förderwinden		M	
Gru					
Meccanismo del braccio di trivellazione	Derricking jib gear	Bohrvorrichtung		M	
Meccanismo di montacarico	Hoist gear	Hebewerke	U		
Meccanismo girevole	Slewing gear	Schwenkwerke		M	
Meccanismo di traslazione	Travelling gear	Fahrwerke			H
Draghe					
Convogliatori a tazza	Bucket conveyors	Eimerkettenbagger			H
Ruote a tazza	Bucket wheels	Schaufelräder			H
Teste portautensili	Cutter heads	Schneidköpfe			H
Verricelli per manovre	Manoeuvring winches	Manövrierwinden		M	
Pompe	Pumps	Saugpumpen		M	
Meccanismo girevole	Slewing gear	Schwenkwerke		M	
Meccanismo di traslazione (mezzo cingolato)	Travelling gear (caterpillar)	Fahrwerke (Raupe)			H
Meccanismo di traslazione (rotaie)	Travelling gear (rails)	Fahrwerke (Schiene)		M	

CONDITIONS DE CHARGE

Les conditions de charge indiquées peuvent varier en fonction des conditions de fonctionnement réelles des réducteurs.

Légendes.

U = Charge uniforme
M = Charge modérée
H = Charge lourde

CONDICIONES DE LA CARGA

Las condiciones de la carga ilustradas pueden variar según las reales condiciones de funcionamiento de los reductores.

Leyenda :

U = Carga uniforme
M = Carga moderada
H = Carga pesada

CONDIÇÕES DE CARGA

As condições de carga aqui indicadas podem variar em função das condições reais de funcionamento dos redutores.

Legenda:

U = Carga uniforme
M = Carga moderada
H = Carga pesada

INTR.

Tableau 3 / Tabla 3 / Tabela 3

Compresseurs, ventilateurs	Compresores, ventiladores	Compressores, ventiladores			
Compresseurs (axiaux et radiaux)	Compresores (axiales y radiales)	Compressores (axiais e radiais)	U		
Ventilateurs à tour de réfrigération	Ventiladores de torre de enfriamiento	Ventiladores em torre de resfriamento		M	
Ventilateurs à tirage induit	Ventiladores de tiro inducido	Ventiladores com tiragem induzida		M	
Compresseurs à pistons rotatifs	Compresores con pistones giratorios	Compressores com pistões rotativos		M	
Turbocompresseurs	Turbocompresores	Turbocompressores	U		
Industrie chimique					
Agitateurs (pour produits liquides)	Agitadores (materiales líquidos)	Agitadores (materiais líquidos)	U		
Agitateurs (pour produits semi-liquides)	Agitadores (materiales semi-líquidos)	Agitadores (materiais semilíquidos)		M	
Centrifugeuses (lourdes)	Centrifugadoras (pesadas)	Centrífugas (pesadas)		M	
Centrifugeuses (légères)	Centrifugadoras (livianas)	Centrífugas (leves)	U		
Tambours refroidisseurs	Tambores de enfriamiento	Tambores de resfriamento		M	
Tambours de séchage	Tambores de secado	Tambores de secagem		M	
Mélangeurs	Mezcladores	Misturadores		M	
Compresseurs					
Compresseurs à piston	Compresores de pistón	Compressores de pistão			H
Turbocompresseurs	Turbocompresores	Turbocompressore		M	
Convoyeurs					
Tapis transporteurs à plaques	Cintas transportadoras de placas	Tapete transportador de placas		M	
Élévateurs de lesté	Elevadores de lastre	Elevadores de lastros		M	
Convoyeurs tapis à poches	Transportadores de cinta con funda	Tapetes transportadores com bolsos		M	
Transporteurs à bandes (matériel volumineux)	Transportadores de cinta (material suelto)	Tapetes transportadores (materiais volumosos)		M	
Transporteurs à bandes (pièces détachées)	Transportadores (mercadería en piezas)	Transportadores (para artigos separados)			H
Convoyeurs à godets pour farine	Transportadores de cangilones para harinas	Transportadores de caçambas para farináceos	U		
Convoyeurs à chaînes	Transportadores de cadena	Transportadores de correntes		M	
Convoyeurs circulaires	Transportadores circulares	Transportadores circulares		M	
Monte-charge	Montacargas	Monta-cargas			H
Monte-charge inclinés	Montacargas inclinados	Monta-cargas inclinados			H
Convoyeurs à tapis en acier	Transportadores de cinta de acero	Transportador de esteira de aço		M	
Ascenseurs	Ascensores para personas	Elevadores para pessoas		M	
Transporteurs à vis sans fin	Transportadores de tornillo	Transportadores de rosca sem fim		M	
Transporteur à tapis concave	Transportadores de cinta cóncava	Transportador de esteira côncava		M	
Transporteurs à treuil	Transportador con guinche	Transportador com guincho		M	
Grues					
Mécanisme du bras de forage	Mecanismo del brazo de perforación	Mecanismo do braço de perfuração		M	
Mécanisme du montecharges	Mecanismo del montacargas	Mecanismo do monta-carga	U		
Mécanisme de rotation	Mecanismo giratorio	Mecanismo giratório		M	
Mécanisme de translation	Mecanismo de traslado	Mecanismo de translação			H
Dragues					
Convoyeurs à godets	Transportadores de cangilones	Transportadores de caçambas			H
Roues à godets	Ruedas de cangilones	Rodas de caçambas			H
Têtes porte-outils	Cabezas portaherramientas	Cabeças porta-ferramentas			H
Treuil de manoeuvre	Guinches para maniobras	Guinchos para manobras		M	
Pompes	Bombas	Bombas		M	
Mécanismes de rotation	Mecanismo giratorio	Mecanismo giratório		M	
Mécanismes de translation (véhicule chenillé)	Mecanismo de translación (vehículo de orugas)	Mecanismo de translação (veículo sobre esteiras)			H
Mécanismes de translation (rails)	Mecanismo de translación (vehículo sobre rieles)	Mecanismo de translação (trilhos)		M	



**CARATTERISTICHE
TECNICHE**



**TECHNICAL
INFORMATION**



**TECHNISCHE
EIGENSCHAFTEN**

CONDIZIONI DI CARICO

Le condizioni di carico qui elencate possono subire variazioni in funzione delle reali condizioni di funzionamento dei riduttori.

LOAD CLASSIFICATION

Listed load conditions may change depending on drive actual operating conditions.

BELASTUNGSKENNWERT

Die Änderung des erforderlichen Belastungskennwertes kann ggf. nach Angabe der genauen Betriebsbedingungen erfolgen.

Legenda:

U = Carico uniforme
M = Carico moderato
H = Carico pesante

Legend:

U = Uniform load
M = Moderate load
H = Heavy load

Legende:

U = gleichmäßige Belastung
M = mittlere Belastung
H = schwere Belastung

Tabella 3 / Table 3 / Tabelle 3

Macchinari per industria alimentare	Food industry machinery	Nahrungsmittelmaschinen			
Macchine per il riempimento di bottiglie e contenitori	Bottling and container filling machines	Abfüllmaschinen	U		
Frantumatori di canna	Cane crushers	Zuckerrohrbecher		M	
Coltelli per canna	Cane knives	Zuckerrohrschneider			H
Macina per canna	Cane mills	Zuckerrohmühlen		M	
Impastatrice	Kneading machines	Knetmaschinen		M	
Vasche per macerazione (cristallizzanti)	Mash tubs (crystallizers)	Maischen			H
Macchinari per imballaggio	Packaging machines	Verpackungsmaschinen		U	
Taglierine per barbabietole da zucchero	Sugar beet cutters	Zuckerrübenschneider	M		
Macchine per il lavaggio di barbabietole da zucchero	Sugar beet washing machines	Zuckerrübenwäscher	M		
Macchinari per costruzione	Building machinery	Baumaschinen			
Betoniere	Concrete mixers	Betonmischmaschinen		M	
Montacarichi	Hoists	Baufzüge		M	
Macchinari per costruzione strade	Road construction machinery	Strassenbaumaschinen		M	
Generatori e trasformatori	Generators, transformers	Generatoren, Umformer			
Trasformatori di frequenza	Frequency transformers	Frequenzumformer			H
Generatori	Generators	Generatoren			H
Generatori per saldatrici	Welding generators	Schweissgeneratoren			H
Lavanderie	Laundries	Wäschereimaschinen			
Invertitori	Tumblers	Trommeltrockner		M	
Lavatrici	Washing machines	Waschmaschinen		M	
Stiratrici	Pressing machines	Bügelmaschinen		M	
Laminatori per metalli	Metal rolling mills	Walzwerke			
Cesoie per laminatoi	Billet shears	Blechscheren			H
Trasmissioni a catena	Chain transfers	Kettenschlepper		M	
Laminatoi a freddo	Cold rolling mills	Kaltwalzwerke			H
Impianti per fusione continua	Continuous casting plant	Stranggussanlagen			H
Basamenti refrigeranti	Cooling beds	Kühlbetten		M	
Cesoie per spuntatura	Cropping shears	Schopfscheren			H
Laminatoi per piatti medi e pesanti	Heavy and medium plate mills	Plattenwalzwerk			H
Treni sbozzatori e lingotti	Descaling machines	Blocktransportanlagen			H
Manipolatori	Manipulators	Verschiebvorrichtungen			H
Trancia lamiera	Ingot pushers	Blechpressen			H
Raddrizzatore rulli	Plate tilters	Rollenrichtmaschinen		M	
Tavole a rulli (pesante)	Roller tables (heavy)	Rollgänge (schwer)			H
Tavole a rulli (leggera)	Roller tables (light)	Rollgänge (leicht)			H
Macchine saldatrici a tubo	Tube welding machines	Rohrschweissmaschinen		M	
Macchine avvolgitrici (guarnizioni e fili)	Winding machines (strip and wire)	Wickler		M	
Banchi da disegno a filo	Wire drawing banches	Drahtzüge		M	
Macchine per la lavorazione del metallo	Metal working machines	Metallbearbeitungsmaschinen			
Contralberi, alberi in linea	Contershafts, line shafts	Vorgelege	U		
Pressa per stampaggio a caldo	Forging presses	Schmiedepressen			H
Martelli	Hammers	Hämmer			H
Guide ausiliarie, macchine utensili	Auxiliary drives, machine tools	Werkzeugmaschinen Hilfsantriebe	U		
Guide principali, macchine utensili	Main drives, machine tools	Werkzeugmaschinen Hauptantriebe		M	
Macchine per la piallatura di metalli	Metal planing machines	Hobelmaschinen			H
Raddrizzatrice per la lamiera	Plate straightening machines	Blechrichtmaschinen			H
Pressa	Presses	Pressen			H
Pressa per stampi	Punch presses	Stanzen			H
Cesoie	Shears	Scheren			M
Macchine per piegatrici di metallo	Sheet metal bending machines	Blechbiegemaschinen			M

CONDITIONS DE CHARGE

Les conditions de charge indiquées peuvent varier en fonction des conditions de fonctionnement réelles des réducteurs.

Légendes.

U = Charge uniforme
M = Charge modérée
H = Charge lourde

CONDICIONES DE LA CARGA

Las condiciones de la carga ilustradas pueden variar según las reales condiciones de funcionamiento de los reductores.

Legenda :

U = Carga uniforme
M = Carga moderada
H = Carga pesada

CONDIÇÕES DE CARGA

As condições de carga aqui indicadas podem variar em função das condições reais de funcionamento dos redutores.

Legenda:

U = Carga uniforme
M = Carga moderada
H = Carga pesada

INTR.

Tableau 3 / Tabla 3 / Tabela 3

Machines pour l'industrie alimentaire	Máquinas para la industria alimenticia	Máquinas para a indústria alimentar			
Machines pour le remplissage de bouteilles et conteneurs	Máquinas para llenar botellas y recipientes	Envasadoras de garrafas e recipientes	U		
Broyeurs de joncs	Trituradores de caña	Trituradores de cana		M	
Lames pour joncs	Cuchillos para caña	Lâminas para cana			H
Moulins de joncs	Muelas para caña	Moinhos de cana		M	
Pétrisseuse	Empastadoras	Amassadeira		M	
Cuves de macération (cristallisantes)	Depósitos para maceración (cristalizadores)	Tanques de maceração (cristalizadores)			H
Machines d'emballage	Máquinas para embalaje	Equipamentos para embalagem		U	
Coupeuses pour betteraves à sucre	Cuchillas para remolacha azucarera	Cortadores para beterraba de açúcar	M		
Machines pour le lavage de betteraves à sucre	Máquinas para lavar la remolacha azucarera	Máquinas para a lavagem de beterraba de açúcar	M		
Machines de construction	Máquinas para la construcción	Máquinas para construção			
Bétonnières	Hormigoneras	Betoneiras		M	
Monte-charge	Montacargas	Monta-cargas		M	
Machines pour la construction de routes	Máquinas para la construcción vial	Máquinas para a construção de rodovias		M	
Générateurs et transformateurs	Generadores y transformadores	Geradores e transformadores			
Transformateurs de fréquence	Transformadores de frecuencia	Transformadores de frequência			H
Générateurs	Generadores	Geradores			H
Générateurs pour machines à souder	Generadores para soldadoras	Geradores para máquinas de solda			H
Laveries	Lavanderias	Lavanderias			
Inverseurs	Invertidores	Inversores		M	
Machines à laver	Lavadoras	Máquinas de lavar		M	
Machines à repasser	Planchadoras	Máquinas de passar		M	
Laminaires a métaux	Laminadores para metales	Laminadores de metais			
Cisailles pour laminaires	Cizallas para laminadores	Cisalhas para laminadores			H
Transmissions à chaîne	Transmisiones de cadena	Transmissões por corrente		M	
Laminaires à froid	Laminadores en frío	Laminadores a frio			H
Installations de fusion continue	Instalaciones para fundición continua	Equipamentos para fusão contínua			H
Bases de réfrigération	Bases de refrigeración	Leitos de resfriamento		M	
Cisailles à ébouter	Cizallas para despunte	Tesouras de recorte de pontas de refugo			H
Laminaires pour plats moyens et lourds	Laminadores para platos medios y pesados	Laminadores para chapas médias e pesadas			H
Trains ébaucheurs et lingots	Trenes desbastadores y lingotes	Máquinas de decapagem			H
Manipulateurs	Manipuladores	Manipuladores			H
Coupe-tôles	Cizallas de planchas	Cortadores de chapa			H
Machines à dresser les rouleaux	Máquinas enderezadoras de rodillos	Aplainadora de rolos		M	
Tables à rouleaux (lourdes)	Mesas de rodillos (pesadas)	Mesas de rolos (pesadas)			H
Tables à rouleaux (légères)	Mesas de rodillos (livianas)	Mesas de rolos (leves)			H
Machines à souder les tubes	Maquinas para soldar	Máquinas de solda de tubos		M	
Enrouleuses (garnitures et fils)	Máquinas bobinadoras (flejes e hilos)	Bobinadeiras (guarnições e fios)		M	
Bancs traceurs à fil	Bancos de diseño a hilo	Bancadas de desenho com fio		M	
Machines d'usinage des métaux	Máquinas para la elaboración del metal	Máquinas para a transformação de metal			
Contre-arbres, arbres en ligne	Contraejes, ejes en línea	Contra-eixos, eixos em linha	U		
Presses à mouler à chaud	Prensa para estampado en caliente	Prensa para moldagem a quente			H
Marteaux	Martillos	Martelos			H
Glissières auxiliaires, machines outils	Guías auxiliares, máquinas herramientas	Guias auxiliares, máquinas operatrizes	U		
Glissières principales, machines outils	Guías principales, máquinas herramientas	Guias principais, máquinas operatrizes		M	
Raboteuses à métaux	Máquinas para el cepillado de metales	Máquinas para o aplainamento de metais			H
Machines à dresser les tôles	Máquinas enderezadoras de chapa	Aplainadoras para chapas			H
Presses	Prensas	Prensas			H
Presses à estamper	Prensas para punzonado	Prensas para moldes			H
Cisailles	Cizallas	Tesouras mecánicas			M
Pliques à métaux	Máquinas para plegado de metal	Máquinas de dobrar metais			M



**CARATTERISTICHE
TECNICHE**



**TECHNICAL
INFORMATION**



**TECHNISCHE
EIGENSCHAFTEN**

CONDIZIONI DI CARICO

Le condizioni di carico qui elencate possono subire variazioni in funzione delle reali condizioni di funzionamento dei riduttori.

Legenda:

U = Carico uniforme
M = Carico moderato
H = Carico pesante

LOAD CLASSIFICATION

Listed load conditions may change depending on drive actual operating conditions.

Legend:

U = Uniform load
M = Moderate load
H = Heavy load

BELASTUNGSKENNWERT

Die Änderung des erforderlichen Belastungskennwertes kann ggf. nach Angabe der genauen Betriebsbedingungen erfolgen.

Legende:

U = gleichmäßige Belastung
M = mittlere Belastung
H = schwere Belastung

Tabella 3 / Table 3 / Tabelle 3

Industria petrolifera	Oil industry	Ölindustrie			
Pompe conduttrici	Pipeline pumps	Pompes pour pipeline			M
Attrezzatura trapanatrice rotante	Rotary drilling equipment	Bohrvorrichtungen			H
Macchine per la carta	Paper machines	Papiermaschinen			
Calandre	Calenders	Kalander			H
Manicotto	Couches	Gautschen			H
Tamburo essiccatore	Drying cylinders	Trockenzylinder			H
Cilindro essiccatore	Glazing cylinders	Glättzylinder			H
Raffinatrice	Pulpers	Holländer			H
Sfibratore per pasta	Pulp grinders	Holzschleifer			H
Rulli aspiranti	Suction rolls	Saugwalzen			H
Presse aspiranti	Suction presses	Saugpressen			H
Presse a umido	Wet presses	Nasspressen			H
Battitoi	Willows	Reisswolf			H
Macchinari per la plastica	Plastic industry machinery	Kunststoffmaschinen			
Calandre	Calenders	Kalander			M
Frantoi	Crushers	Zerkleinerungsmaschinen			M
Estrusori	Extruders	Extruder			M
Miscelatori	Mixers	Mischer			M
Pompe	Pumps	Pumpen			
Pompa centrifuga (liquidi leggeri)	Centrifugal pumps (light liquids)	Kreiselpumpen (zähe Flüssigkeit)	U		
Pompa centrifuga (liquidi viscosi)	Centrifugal pumps (viscous liquids)	Kreiselpumpen (leichte Flüssigkeit)			H
Pompe a pistoni	Piston pumps	Kolbenpumpen			H
Pompe a pulsante	Plunger pumps	Plungerpumpen			H
Pompe a pressione	Pressure pumps	Presspumpen			H
Macchinari per la gomma	Rubber machinery	Gummimaschinen			
Calandre	Calenders	Kalander			M
Estrusori	Extruders	Extruder			H
Miscelatori	Mixers	Mischer			M
Impastatrice	Pug mills	Knetwerke			H
Laminatoi	Rolling mills	Walzwerke			H
Macchine per la lavorazione della pietra e dell'argilla	Stone and clay working machines	Steine, Erden			
Mulino a martelli	Hammer mills	Hammermühlen			H
Laminatoi per raffinare	Beater mills	Walzwerk			H
Interruttore	Breakers	Brecher			H
Presse per mattoni	Brick presses	Ziegelpressen			H
Forno rotante	Rotary ovens	Drehöfen			H
Laminatoi a tubo	Tube mills	Rohrmühlen			H
Macchine tessili	Textile machines	Textilmaschinen			
Dosatori	Batchers	Dosierer			M
Telai per tessitura	Looms	Webstühle			M
Macchine per la stampa e la tintura	Printing and dyeing machines	Druckerei-Färbereimaschinen			M
Vasca per la concia	Tanning vats	Gerbwanne			M
Battitoi	Willows	Reisswolf			M
Trattamenti ad acqua	Water treatment	Wasseraufbereitung			
Aeratori	Aerators	Kreiselpelüfter			M
Pompa a vite	Screw pumps	Wasserschnecken			M
Macchine per la lavorazione del legno	Wood working machines	Holzbearbeitungsmaschinen			
Scortecciatrici	Barkers	Sägegatter			H
Macchine per la piallatura	Planing machines	Hobelmaschinen			M
Telaio per seghe	Saw frames	Entrindungstrommel			H
Macchine per la lavorazione del legno	Wood working machines	Holzbearbeitungsmaschinen	U		

CONDITIONS DE CHARGE

Les conditions de charge indiquées peuvent varier en fonction des conditions de fonctionnement réelles des réducteurs.

Légendes.

U = Charge uniforme
M = Charge modérée
H = Charge lourde

CONDICIONES DE LA CARGA

Las condiciones de la carga ilustradas pueden variar según las reales condiciones de funcionamiento de los reductores.

Leyenda :

U = Carga uniforme
M = Carga moderada
H = Carga pesada

CONDIÇÕES DE CARGA

As condições de carga aqui indicadas podem variar em função das condições reais de funcionamento dos redutores.

Legenda:

U = Carga uniforme
M = Carga moderada
H = Carga pesada

INTR.

Tableau 3 / Tabla 3 / Tabela 3

Industrie pétrolière	Industria del petróleo	Indústria petrolífera			
Pompes pour pipeline	Bombas conductoras	Bombas condutoras			M
Équipement de forage rotatif	Equipos perforado rotativo	Equipamentos para perfuradora rotativa			H
Industrie papetière	Máquinas para el papel	Máquinas para a indústria do papel			
Calandres	Calandras	Calandras			H
Fourreaux	Manguitos	Mangas			H
Tambours de séchoir	Tambores de secado	Tambor secador			H
Cylindres de séchoir	Cilindros de secado	Cilindro secador			H
Raffineurs	Refinadoras	Refinadora			H
Défilbreurs de pâte	Desfibrador de pasta	Desfibrador para pasta			H
Rouleaux aspirants	Rodillos aspiradores	Rolos aspiradores			H
Presses aspirantes	Prensas aspiradoras	Prensas aspiradoras			H
Presses humides	Prensas en húmedo	Prensas a úmido			H
Battoirs	Batidores	Batedores			H
Machines pour matières plastiques	Máquinas para el plástico	Máquinas para a indústria do plástico			
Calandres	Calandras	Calandras			M
Broyeurs	Trituradores	Trituradores			M
Extrudeuses	Extrusores	Extrusoras			M
Mélangeurs	Mezcladores	Misturadores			M
Pompes	Bombas	Bombas			
Pompes centrifuges (liquides légers)	Bombas centrifugadoras (líquidos livianos)	Bomba centrífuga (líquidos leves)		U	
Pompe centrifuges (liquides visqueux)	Bombas centrifugadoras (líquidos viscosos)	Bomba centrífuga (líquidos viscosos)			H
Pompes à pistons	Bombas de pistón	Bombas de pistões			H
Pompes à pousoir	Bombas de émbolo	Bombas de êmbolo			H
Pompes à pression	Bombas de presión	Bombas de pressão			H
Machines pour le caoutchouc	Máquinas para la goma	Máquinas para a indústria da borracha			
Calandres	Calandras	Calandras			M
Extrudeuses	Extrusores	Extrusoras			H
Mélangeurs	Mezcladores	Misturadores			M
Malaxeur	Empastadoras	Amassadeira			H
Laminaires	Laminadores	Laminadores			H
Machines pour le travail de la pierre et de l'argile	Máquinas para la elaboración de la piedra y de la arcilla	Máquinas para a transformação de pedras e argila			
Moulins à marteau	Molinos de martillo	Moinho de martelos			H
Laminaires à raffiner	Laminadores para refinar	Laminadores para refinar			H
Interrupteurs	Interruptores	Interruptor			H
Presses à briques	Prensas para ladrillos	Prensas para tijolos			H
Fours rotatifs	Hornos rotativos	Forno rotativo			H
Laminaires à tubes	Laminadores de tubo	Laminadores de tubo			H
Machines pour l'industrie textile	Máquinas textiles	Máquinas têxteis			
Doseurs	Dosificadores	Dosadores			M
Métiers à tisser	Máquinas para tejido	Máquinas de tecelagem			M
Machines pour l'impression et la teinture	Máquinas para imprimir y teñir	Máquinas de estamperia e tinturaria			M
Cuves de tannage	Depósitos para curtiembre	Tanques de curtição			M
Battoirs	Batidores	Batedores			M
Traitement des eaux	Tratamientos con agua	Tratamentos com água			
Aérateurs	Aireadores	Aeradores			M
Pompes à vis	Bombas de tornillo	Bombas de rosca			M
Machines à travailler le bois	Máquinas para la elaboración de la madera	Máquinas para trabalhar madeira			
Machines à décortiquer	Descortezadoras	Máquinas de descortçar			H
Raboteuses	Máquinas para el cepillado	Máquinas de aplainamento			M
Métiers à scies	Marcos para sierras	Armação para serras			H
Machines à bois	Máquinas para la elaboración de la madera	Máquinas para trabalhar madeira		U	



NORME GENERALI PER L'INSTALLAZIONE E LA MANUTENZIONE

Per garantire un buon funzionamento dei riduttori ed una miglior durata nel tempo è necessario un corretto accoppiamento alla struttura cui viene fissato il gruppo. Pertanto le superfici di tale struttura dovranno essere lavorate con centraggi in H8 ed in modo da garantire un'ottima planarità e perpendicolarità con l'asse del riduttore.

Per il fissaggio del riduttore usare la bulloneria indicata sotto ogni disegno nelle schede tecniche di prodotto. Usare inoltre tutti i fori di fissaggio previsti sulle flange dei riduttori.

Per gruppi installati all'aperto si consiglia, dove possibile, di proteggere i riduttori dalle intemperie, di trattarli con sistemi anticorrosivi e di proteggere i paraoli con grasso idrorepellente.

Nelle applicazioni in cui possono verificarsi sovraccarichi accidentali tali da compromettere l'integrità della trasmissione, occorre prevedere un sistema di sicurezza (idraulico, meccanico) per salvaguardare il riduttore.

L'abbinamento fra riduttori e motori, principalmente elettrici o idraulici, viene normalmente fatto mediante flangiatura diretta quando non si presentano particolari condizioni di criticità, che possono provocare danni dopo l'installazione.

A tale proposito, ove è richiesto di installare motori molto pesanti, oltre i 100 Kg, consigliamo di contattare il nostro Servizio Tecnico-Commerciale, per meglio valutare l'applicazione in funzione della posizione di montaggio.

In alternativa, si consiglia un montaggio separato dei due particolari collegati mediante giunto o pulegge.

SMALTIMENTO DELLA MACCHINA

Lo smaltimento dei rifiuti derivati dalla demolizione della macchina dovrà essere eseguito nel rispetto ambientale, evitando di inquinare suolo, aria e acqua. I rifiuti derivanti dalla demolizione della macchina sono classificabili come rifiuti speciali. In ogni caso dovranno essere rispettate le locali legislazioni e le normative di tutela ambientali nel rispetto delle leggi vigenti in materia nel paese di utilizzo della macchina.

Materiali ferrosi: trattasi di materiale riciclabile (materie prime secondarie) da conferire ad apposito centro di raccolta autorizzato.

Materiali plastici: riciclo consentito ove effettuato, smaltimento in discarica per rifiuti assimilabili agli urbani, incenerimento consentito in impianto dotato di post-combustione e sistema di abbattimento polveri prima dell'immissione in atmosfera.

GENERAL MOUNTING AND MAINTENANCE INSTRUCTIONS

For the longest and most efficient service life, drives must be correctly mounted on the application structure. Therefore, all structure faces must be machined with H8 spigots so that they are flat and perpendicular to the drive axis.

To secure the drive, use the nuts and bolts shown under each technical drawing on the product technical sheets. Make sure to use all the fixing holes on the flanges.

For outdoor installations, drives must be protected against bad weather, treated with anticorrosive agents and oil seals protected with water-repellent grease.

In operations in which transmission malfunctions might occur due to accidental overloads, a mechanical or hydraulic safety device must be used to protect the drive.

Drives are usually connected directly to what are mainly electric or hydraulic motors by means of flanges when there are particularly critical conditions that might cause damage after installation.

With this in mind, and when heavy motors must be installed (weighing more than 100 Kg), please contact our Technical-Commercial Service Department, to evaluate the proper mounting position.

As an alternative, we suggest to separately mount the two units and to connect them with either a coupling or pulleys.

MACHINE DISPOSAL

Disposing of waste deriving from demolition of the machine must be done with the environment in mind, avoiding pollution of the soil, air and water. Waste from demolition of the machine is classified as special waste. Local laws and environmental protection regulations must in any case be observed, in compliance with the environmental laws in force in the country where the machine is used.

Ferrous materials: these are recyclable (secondary raw materials) to be delivered to a special authorised collection centre.

Plastic materials: recycling permitted where done, disposal in landfill for waste similar to urban waste, incineration allowed in plant equipped with post-combustion and dust damping system before being released into the air.

ALLGEMEINE VORSCHRIFTEN FÜR EINBAU UND WARTUNG

Der korrekte Einbau des Getriebes in die entsprechende Vorrichtung der Applikation ist Voraussetzung, um einen einwandfreien und dauerhaften Betrieb zu gewährleisten. Vorallem die Oberflaechen der Zentrierungen/ Aufnahme sind in einer Toleranz H8 zu fertigen, damit die einwandfreie Uebereinstimmung mit der Getriebeachse garantiert wird.

Für die Befestigung sind die Schrauben zu verwenden, die in der Zeichnung/ Teilleiste des Modells vorgesehen sind. Dazu sind alle vorgesehenen Befestigungsbohrungen zu verwenden.

Für im Freien betriebene Maschinen wird empfohlen, das Getriebe soweit wie möglich vor Witterungseinflüssen zu schützen sowie mit Rostschutzmittel zu behandeln. Die Dichtringe sind mit wasserabweisendem Fett zu versehen.

Bei Betriebsbedingungen, unter denen Dauerstörungen aufgrund unvorhergesehener Überlastungen auftreten könnten oder gar die Getriebewelle blockiert werden könnte, empfiehlt sich der Einbau eines hydraulischen oder mechanischen Sicherheitssystems zum Schutz des Getriebes.

Der Anbau des Getriebes an Elektro- oder Hydraulikmotoren erfolgt normalerweise direkt über Flansche, wenn keine außergewöhnliche Situation vorliegt, die nach erfolgtem Einbau Schäden verursachen könnte.

Ist es jedoch erforderlich, sehr schwere Motoren anzubauen, deren Gewicht 100 kg überschreitet, wird empfohlen, sich an unseren Kundenservice (sales) zu wenden, um die beste Einbauposition zu ermitteln.

Alternativ dazu kann ein separater Einbau der beiden Teile erfolgen, die dann über Kupplungen oder Riemenscheiben verbunden werden.

ENTSORGUNG DER MASCHINE

Die Entsorgung des bei der Verschrottung der Maschine anfallenden Abfalls muss unter Beachtung der Umweltschutzgesetze erfolgen. Boden, Luft und Wasser dürfen nicht verschmutzt werden. Der anfallende Abfall ist als Sondermüll zu betrachten. Auf jeden Fall müssen die örtlichen Gesetze und Vorschriften zum Schutz der Umwelt des Landes, in dem die Maschine verwendet wird, befolgt werden.

Eisenhaltige Materialien: Da es sich um recyclingfähiges Material handelt (sekundäre Rohstoffe), sind diese einer zugelassenen Rohstoffsammlung zu übergeben.

Kunststoffmaterialien: Recycling zulässig wo möglich, Entsorgung auf der Müllhalde von unter Hausmüll fallendem Abfall, Verbrennung zugelassen in Anlagen mit Nachverbrennung und Entstaubungsanlage vor dem Ablassen in die Atmosphäre.

**REGLES GENERALES D'INSTALLATION
ET D'ENTRETIEN**

Pour garantir le bon fonctionnement des réducteurs et leur durée de vie maximum, il est indispensable d'assurer un bon accouplement à la structure sur laquelle le groupe doit être fixé. Aussi, les surfaces de cette structure doivent être usinées par des centrages en H8 et de façon à garantir une planéité optimale et une perpendicularité par rapport à l'axe du réducteur.

Pour effectuer la fixation du réducteur, utiliser les boulons indiqués sous chaque dessin des fiches techniques du produit. En outre, utiliser tous les trous de fixation prévus sur les brides des réducteurs.

Pour les groupes installés à ciel ouvert, il est conseillé, dans la mesure du possible, de mettre les réducteurs à l'abri des intempéries, de les traiter avec des produits anti-corrosion et de protéger les joints d'étanchéité à l'aide de la graisse hydrofuge.

Dans le cas des applications exposées à des risques de surcharges accidentelles susceptibles de compromettre la transmission, il est nécessaire de prévoir un dispositif de sécurité (hydraulique ou mécanique) de protection du réducteur.

L'assemblage des réducteurs aux moteurs, principalement électriques ou hydrauliques, est généralement assuré par bridage direct en l'absence de conditions critiques particulières susceptibles d'endommager l'installation.

A cet égard, lorsque s'avère nécessaire l'installation de moteurs très lourds, de plus de 100 kg, il est recommandé de prendre contact avec notre Service Technico-Commercial qui vous aidera à mieux étudier l'application en fonction de la position de montage.

Différemment, il est recommandé d'effectuer un montage séparé des deux éléments et de les relier l'un à l'autre par l'intermédiaire d'un joint ou de poulies.

DÉMOLITION DE LA MACHINE

L'élimination des déchets provenant de la démolition de la machine doit s'effectuer dans le respect de l'environnement pour prévenir la pollution des sols, de l'air et des eaux. Les déchets provenant de la démolition de la machine rentrent dans la catégorie des déchets spéciaux. Dans tous les cas, il est nécessaire de veiller au respect des dispositions locales et des autres normes de protection de l'environnement, en conformité aux lois en vigueur dans le pays où la machine est utilisée.

Matériaux ferreux: matériaux recyclables (matières premières secondaires) à remettre à un centre de collecte agréé.

Matières plastiques: recyclage autorisé, élimination en décharge pour déchets assimilables aux déchets urbains, incinération autorisée dans des installations à post-combustion et à système de filtrage des poussières avant rejet dans l'atmosphère.

**NORMAS GENERALES PARA LA
INSTALACIÓN Y EL MANTENIMIENTO**

Para garantizar un buen funcionamiento de los reductores y una mayor duración se deberá realizar un correcto acoplamiento a la estructura en la que se fija el grupo. Por tanto las superficies de dicha estructura tendrán que estar bien planas y los ejes de los agujeros respetar una tolerancia H8, de este modo se podrá garantizar una óptima planaridad y perpendicularidad con el eje del reductor.

Para efectuar la fijación del reductor, utilizar los boulons indicados en los planos de las fichas técnicas del producto. En outre, utilizar todos los agujeros de fijación previstos en las bridas de los reductores.

Para los grupos instalados al aire libre se aconseja, donde sea posible, proteger los reductores contra la intemperie, tratarlos con sistemas contra la corrosión y proteger los sellos de lubricación con grasa hidrófuga.

En las aplicaciones donde se pueden producir sobrecargas accidentales, capaces de comprometer la integridad de la transmisión, se deberá utilizar un sistema de seguridad (hidráulico o mecánico) para salvaguardar el reductor.

El montaje entre los reductores y los motores, principalmente eléctricos o hidráulicos, generalmente se realiza con embridado directo siempre que no se presenten particulares condiciones críticas que podrían ocasionar daños después de la instalación.

Para tal fin, donde se requiera la instalación de motores muy pesados (más de 100 Kg), se aconseja ponerse en contacto con nuestro Servicio Técnico-Comercial, para poder evaluar mejor la aplicación en función de la posición de montaje.

Como alternativa, se aconseja un montaje separado de las dos unidades y acoplarlas por medio de juntas o poleas.

DEMOLICIÓN DE LA MÁQUINA

Los residuos derivados de la demolición de la máquina deberán eliminarse respetando el medio ambiente, evitando contaminar suelo, aire y agua. Los residuos derivados de la demolición de la máquina se clasifican como residuos especiales. De todos modos, se deberán respetar las legislaciones y normativas locales de protección del medio ambiente observando las leyes vigentes en la materia del país donde se utiliza la máquina.

Materiales ferrosos: se trata de materiales reciclables (materias primas secundarias) que deben enviarse a los correspondientes centros de recolección autorizados.

Materiales plásticos: reciclado permitido si fuere necesario efectuarlo, eliminación en vertederos para residuos asimilables a los urbanos, incineración permitida en instalaciones con post-combustión y sistema de abatimiento de polvo antes de ingresar a la atmósfera.

**NORMAS GERAIS PARA A INSTALAÇÃO
E MANUTENÇÃO**

Para garantir o bom funcionamento dos reductores e uma maior durabilidade deles, é indispensável assegurar um acoplamento correto na estrutura onde a unidade é fixada. Portanto, as superfícies desta estrutura devem ser usinadas com assentos em tolerância H8 e de maneira a garantir uma perfeita planaridade e perpendicularidade com o eixo do reductor.

Para fijar el reductor hay que utilizar los bulones indicados en los planos de las fichas técnicas del producto. Controlar que se hayan utilizado todos los agujeros de fijación de las bridas.

Para as unidades instaladas ao ar livre aconselha-se, quando possível, proteger os reductores contra os agentes atmosféricos, tratá-los com sistemas anticorrosivos e proteger os retentores de óleo com graxa hidrorrepelente.

Para as aplicações nas quais podem ocorrer sobrecargas acidentais capazes de prejudicar a integridade da transmissão, é preciso instalar um sistema de segurança (hidráulico ou mecânico) para proteger o reductor.

A união entre reductores e motores, sobretudo elétricos ou hidráulicos, é feita normalmente mediante fixação direta por flange quando não existirem condições críticas particulares que possam causar danos após a instalação.

Neste sentido, quando for preciso instalar motores muito pesados, com peso superior a 100 kg, aconselhamos o usuário a entrar em contato com o nosso Serviço Técnico Comercial para avaliar melhor a aplicação em função da posição de montagem.

Como alternativa, aconselha-se a montagem separada das duas unidades ligando-as através de acoplamento ou polias.

DÉMOLITION DE LA MACHINE

O descarte dos resíduos derivados da desmontagem da máquina deverá ser realizado no respeito ao meio ambiente, evitando a poluição do solo do ar e da água. Os resíduos derivados da desmontagem da máquina são classificados como resíduos especiais. Em todo caso, deverão ser respeitadas as legislações e normativas locais de proteção do meio ambiente no respeito às leis vigentes no país de utilização da máquina.

Materiais ferrosos: trata-se de materiais recicláveis (matérias primas secundárias) que devem ser enviados aos apropriados centros de recolha autorizados.

Materiais plásticos: reciclagem permitida se necessária efectua-la, descarte em desaguardo para resíduos semelhantes aos urbanos, incineração permitida em instalações com post-combustão e sistema de abatimento de pó antes da emissão na atmosfera.





**GRUPPI CON FISSAGGIO A FLANGIA
AVANZATA O SENZA FLANGIA**

Riduttori con albero lento maschio (M-P)

Per tali gruppi, quando i carichi sono superiori del 50% rispetto a quelli indicati nei grafici riportati nelle singole schede di prodotto, si consiglia di utilizzare entrambi i centraggi previsti sulla scatola lato uscita. In tutti i casi, invece, devono essere utilizzati i centraggi previsti sugli alberi scanalati, soprattutto quando vengono montati dei pignoni dentati.

Nelle applicazioni dove si verificano condizioni di forti carichi esterni agenti contemporaneamente sia sull'uscita che sull'entrata, si consiglia di contattare il nostro Servizio Tecnico-Commerciale.

Riduttori con albero lento femmina (F)

Per la tipologia di costruzione questi riduttori sono idonei alla trasmissione della pura coppia. Occorre quindi curare particolarmente la coassialità e l'ortogonalità nel collegamento con l'albero condotto.

Riduttori a basamento con piedi (CPC)

Anche per questi gruppi occorre che siano verificate le condizioni di fissaggio relative a coassialità ed ortogonalità già elencate all'inizio di questo capitolo.

Occorre inoltre controllare adeguatamente l'allineamento del gruppo con la macchina da movimentare. Se si hanno dei dubbi sulla perfetta riuscita di tale operazione, utilizzare un collegamento non rigido fra riduttore e macchina, ad esempio un giunto elastico.

Durante l'installazione considerare che il riduttore così montato non deve essere soggetto a fenomeni di vibrazione.

**UNITS WITH FLANGE CLAMPING OR
WITHOUT FLANGE MOUNTING**

Drive with male output shaft t (M-P)

For these units, when the loads are 50% greater than those indicated on the single product technical sheets, use both spigots on the output housing. In all other cases, especially when toothed pinions are mounted, the spigots on the splined output shafts must be used.

In applications where heavy external load conditions act simultaneously on both the output and the input sides, please contact our Technical-Commercial Service Department.

Drives with female output shaft (F)

Thanks to their construction design, these drives are particularly suitable for transmitting pure torque. Therefore always check that the shaft is concentric and in-line with the axis of the driven shaft.

Foot mounted drives (CPC)

The fastening conditions with respect to the concentricity and alignment as discussed in the beginning of this section, also apply to these units.

Ensure that the unit is properly aligned with the machine to be operated. Should you have any doubts about the outcome of this operation, connect a flexible coupling between the drive and the machine.

Ensure that the mounted drive is not subjected to vibrations.

**EINHEITEN MIT BEFESTIGUNG DURCH
VORGESCHOBENEN FLANSCH BZW.
OHNE FLANSCH**

Getriebe mit Abtriebswelle (M-P)

Werden bei Einheiten dieser Art Leistungen angelegt, die die Werte der den jeweiligen Produkten zugeordneten technischen Datenblätter um 50% überschreiten, wird empfohlen, beide Zentrierungen, die am Gehäuse abtriebsseitig vorhanden sind, zu verwenden. Dagegen gilt grundsätzlich in allen Fällen: vorhandene Zentrierungen an den Nutwellen verwenden, vor allem, wenn Ritzel montiert werden.

Bei Betriebsbedingungen, unter denen starke äußere Belastungen gleichzeitig am Abtrieb und Antrieb wirken, wird empfohlen, sich an unseren Kundenservice zu wenden.

Getriebe mit innenverzahnter Hohlwelle (F)

Diese Getriebeausführung kann weder Radial- noch Axialkräfte übertragen.

Es muß deshalb besonders sorgfältig darauf geachtet werden, daß der Anbau an die Hohlwelle koaxial und rechtwinklig erfolgt.

Getriebe mit Befestigungsfüssen (CPC)

Auch bei diesen Einheiten gelten die zu Beginn des Kapitels erwähnten Vorschriften in Bezug auf einen koaxialen und rechtwinkligen Anbau.

Außerdem muß die Ausrichtung der Einheit mit der zu bewegenden Maschine entsprechend kontrolliert werden. Sollte dieses nicht einwandfrei garantiert werden können, ist zwischen Getriebe und Maschine eine flexible Verbindung einzubauen, z.B. eine elastische Kupplung.

Beim Einbau ist zu beachten, daß das auf diese Weise angebaute Getriebe keinen Vibrationen ausgesetzt werden darf.

**GROUPES AVEC FIXATION A BRIDE
AVANCEE OU SANS BRIDE****Réducteurs à arbre lent mâle (M-P)**

Pour de tels groupes, lorsque les charges sont supérieures de 50% à celles indiquées dans les graphiques des fiches des produits, il est recommandé d'utiliser les deux centrages prévus sur la carcasse, côté sortie.

Dans tous les cas, il est nécessaire d'utiliser les centrages prévus sur les arbres cannelés, en particulier quand sont montés des pignons dentés.

Dans le cas des applications présentant de fortes charges extérieures agissant simultanément sur la sortie et sur l'entrée, il est recommandé de prendre contact avec notre Service Technico-Commercial.

**GRUPOS DE FIJACIÓN CON BRIDA
AVANZADA O SIN BRIDA****Reductores con eje lento macho (M-P)**

Para dichos grupos, cuando las cargas superen en un 50% a los valores indicados en los gráficos de cada una de las fichas del producto, se aconseja la utilización de ambos centrages previstos en la carcasa, lado salida.

En todos los otros casos, sobretodo cuando se montan los piñones dentados, se tendrán que utilizar los centrages previstos en los ejes ranurados.

En las aplicaciones con cargas externas pesadas que intervienen simultáneamente en la salida y entrada, se aconseja ponerse en contacto con nuestro Servicio Técnico-Comercial.

**UNIDADES COM FIXAÇÃO POR FLANGE
OU SEM FLANGE****Redutores com eixo lento macho (M-P)**

Para estas unidades, quando as cargas são 50% maiores do que os valores indicados nos gráficos reproduzidos nas fichas de cada produto, aconselha-se a utilização de ambos os assentos existentes na carcaça, no lado da saída.

Em todos os outros casos devem ser utilizadas os assentos existentes nos eixos estriados, principalmente quando forem montados pinhões dentados.

Nas aplicações em que ocorrem condições de fortes cargas externas atuando simultaneamente tanto na saída, como na entrada, aconselha-se a entrar em contato com o nosso Serviço Técnico Comercial.

Réducteurs à arbre lent femelle (F)

Le type de construction de ces réducteurs permet de transmettre le couple pur.

Il est par conséquent nécessaire de bien veiller à la co-axialité et à l'orthogonalité de l'accouplement avec l'arbre mené.

Reductores con eje lento hembra (F)

Debido al tipo de construcción estos reductores son idóneos para transmitir pares puros. Por tanto siempre hay que controlar la coaxialidad y la ortogonalidad del acoplamiento con el eje conducido.

Redutores com eixo lento fêmea (F)

Pelo seu tipo construção, estes reductores são adequados para a transmissão de torque puro. É por isso necessário garantir a coaxialidade e a ortogonalidade na ligação com o eixo conduzido.

Reducteurs a carcasse avec pieds (CPC)

Pour ces groupes également, il est nécessaire de vérifier les conditions de fixation quant à la co-axialité et l'orthogonalité (voir début du chapitre).

De plus, il est nécessaire contrôler soigneusement l'alignement du groupe avec la machine à actionner.

Au moindre doute quant à la réussite de cette opération, utiliser un accouplement non rigide entre réducteur et machine, par exemple un joint élastique.

Lors de l'installation, ne pas oublier que le réducteur ainsi monté ne doit subir aucun phénomène de vibration.

Reductores con carcasa con pie (CPC)

También para estos grupos se tendrán que verificar las condiciones de fijación respecto a la coaxialidad y ortogonalidad que ya fueron enunciadas al comienzo de este capítulo.

Además hay que controlar la alineación del grupo con la máquina a accionar.

Si se tienen dudas sobre el buen resultado de dicha operación, entre el reductor y la máquina hay que utilizar un acoplamiento que no sea rígido, por ejemplo: una junta elástica.

Durante la instalación hay que tener en cuenta que el reductor no esté solicitado con vibraciones.

Redutores com carcaça munida de pés (CPC).

Também para estas unidades é preciso verificar as condições de fixação em termos de coaxialidade e ortogonalidade, já citadas no início deste capítulo.

Além disso, é preciso controlar cuidadosamente o alinhamento da unidade com a máquina que deverá ser acionada.

Se tiver dúvidas acerca do resultado desta operação, utilize uma ligação não rígida entre o reductor e a máquina, por exemplo um acoplamento flexível.

Durante a instalação, lembre-se de que o reductor montado desta maneira não deve ficar sujeito a vibrações.



Riduttori per montaggio pendolare (FS)

Per l'installazione di questi riduttori si prescrive l'applicazione di un braccio di reazione che rispetti le lunghezze minime riportate a disegno per ogni singolo gruppo.

Inoltre, si consiglia di ammortizzare il vincolo di reazione con elementi in gomma e/o ammortizzatori.

In caso di applicazione di motori molto pesanti o di montaggio con cinghia sul lato entrata, contattare il nostro Servizio Tecnico-Commerciale per verificare l'installazione. In questi casi si producono, infatti, carichi esterni che, aggiungendosi a quelli della trasmissione, possono ridurre sensibilmente la vita dei cuscinetti, compromettere l'efficacia del serraggio dell'anello calettatore o influire sulla resistenza dell'albero.

Per garantire un efficiente accoppiamento riduttore-utente, occorre sgrassare opportunamente la superficie interna dell'albero del riduttore e il relativo albero maschio di accoppiamento.

Per un corretto serraggio dell'anello calettatore si raccomanda di serrare le viti in modo graduale ed uniforme, con sequenza continua.

Per la rimozione, occorre svitare gradualmente le viti nello stesso modo in cui sono state avvitate, cioè con sequenza continua e graduale.

Si consiglia di far compiere 1/3 di giro ad ogni vite nella prima sequenza di allentamento, in modo da evitare eventuali intrasamenti.

Procedere poi allo sbloccaggio totale, ma sempre gradualmente e senza arrivare all'estrazione totale delle viti dai filetti.

È consigliabile realizzare l'albero maschio da accoppiare ai gruppi Planetary Drives in tolleranza h6.

Seguire, inoltre, le indicazioni riportate a lato di ogni disegno.

Shaft-mounted drives (FS)

Before installing these drives, apply a torque arm that respects the minimum lengths shown on the drawing for each single unit.

It is also recommended to cushion the reaction constraint using rubber pieces and/or shock absorbers.

When installing very heavy motors or for a belt mounting on the input side, please contact our Technical-Commercial Service Department.

These external and transmission load conditions might significantly shorten bearing service life, loosening shrink disc tightness or affecting shaft resistance.

To ensure that the drive-driven equipment coupling is as efficient as possible, thoroughly degrease the internal surface of the drive shaft and its male coupling shaft.

Tighten the screws on the shrink disc in a gradual and uniform manner in a continuous sequence.

To remove the unit, gradually loosen the screws in the same order that they were tightened; i.e. in a gradual and continuous sequence.

Each screw should be backed off one third turn during the first loosening sequence to avoid any misalignment.

Then proceed to completely unfasten the unit, always in a gradual manner without completely removing the screw from the threads.

It is recommended to use tolerance h6 for the male shafts to be connected to the Planetary Drives.

In addition, follow the instructions provide next to each drawing.

Getriebe mit Hohlwelle für Anbau einer Schrumpfscheibe (FS)

Für den Einbau dieser Getriebe sollte die Achsstrebe die Mindestlänge aufweisen, die in der Zeichnung der jeweiligen Einheit angegeben ist.

Außerdem wird empfohlen, die Achsverbindung mit Gummi- und/oder stoßdämpfenden Elementen abzufedern. Bei besonderen Montagebedingungen, bei denen der Anbau von sehr schweren Motoren vorgesehen ist oder Zugkräfte von außen am Eingang wirken, sollten Sie sich an unseren Kundenservice (sales) wenden, um den Anbau zu überprüfen. Summieren sich Sonderbelastungen dieser Art und Radialkräfte, kann die Lebensdauer der Lager erheblich eingeschränkt werden sowie die Wirksamkeit der Kupplungsspannung reduziert und die Lebensdauer der Welle beeinflusst werden.

Vor dem Anziehen der Reibschlußverbindung wird empfohlen, die Innenfläche der Getriebewelle und die entsprechende Zapfwelle von Fett zu befreien.

Festziehen die Schrauben langsam und gleichmäßig, ohne Unterbrechung, anziehen.

Zum Lösen der Verbindung sind die Schrauben auf dieselbe Weise, gleichmäßig und ohne Unterbrechung zu lösen.

Es wird empfohlen, jede Schraube um eine Drittel-Drehung im ersten Lockerungsvorgang zu lösen, damit eine eventuelle Verschiebung verhindert wird.

Danach die Schrauben vollständig lösen, jedoch immer gleichmäßig und ohne sie aus den Gewinden zu nehmen.

Die an die Planetary Drives anzuschließende Welle sollte eine Toleranz von h6 aufweisen.

Ansonsten sind die Daten in den technischen Zeichnungen zu beachten.

Réducteur pour montage pendulaire (FS)

Pour l'installation de ces réducteurs, il est nécessaire d'appliquer un bras de réaction respectant les longueurs minimales indiquées sur le plan de chaque groupe.

En outre, il est conseillé d'amortir le lien de réaction au moyen d'éléments en caoutchouc et/ou d'amortisseurs.

En cas d'application de moteurs très lourds ou de montage avec courroie sur le côté entrée, prendre contact avec notre Service Technico-Commercial pour contrôler l'application.

Dans de tels cas en effet, sont induites des charges externes qui, ajoutées aux charges de transmission, peuvent réduire sensiblement la durée de vie des roulements, compromettre l'efficacité du serrage de la frette ou avoir une influence sur la résistance de l'arbre..

Pour garantir l'efficacité de l'accouplement réducteur-machine, il est nécessaire de dégraisser la surface interne de l'arbre du réducteur ainsi que l'arbre mâle de couplage correspondant.

Pour le bon serrage de la frette, il est recommandé de serrer les vis de manière graduelle et uniforme en séquence continue.

Pour le retrait du réducteur, il est nécessaire de dévisser graduellement les vis comme lors du serrage, c'est-à-dire en séquence continue et graduelle.

Il est conseillé de dévisser de 1/3 de tour chaque vis lors de la première séquence de desserrage, de façon à éviter les éventuelles mises de travers.

Débloquer ensuite les vis totalement, mais toujours graduellement et sans retirer les vis des filetages.

Il est conseillé de réaliser l'arbre mâle à accoupler aux groupes Planetary Drives avec une tolérance h6.

Par ailleurs, il est conseillé de suivre les indications figurant en marge de chaque dessin.

Reductores para montaje pendular (FS)

Para la instalación de estos reductores es necesario aplicar un brazo de reacción que respete las longitudes mínimas indicadas en el plano para cada grupo.

Además, se aconseja amortiguar el vínculo de reacción con elementos de goma y/o amortiguadores.

En el caso de aplicaciones de motores muy pesados o de montaje con correa en la entrada, se aconseja ponerse en contacto con nuestro Servicio Técnico-Comercial para verificar la instalación.

En efecto, en estos casos se producen cargas externas que, agregándose a aquellas de la transmisión, pueden reducir sensiblemente la vida útil de los rodamientos y perjudicar la eficacia del ajuste del disco de contracción o influir sobre la resistencia del eje.

Para garantizar un acoplamiento eficiente entre reductor-máquina, hay que desengrasar bien la superficie interna del eje reductor y el respectivo eje macho de acoplamiento.

Para un correcto cierre del disco de contracción se recomienda apretar los tornillos en modo gradual, uniforme y en secuencia continua.

Para la remoción, se deberán aflojar los tornillos del mismo modo que para el ajuste o sea, en secuencia continua y gradual.

Mientras se aflojen los tornillos, se aconseja hacerles dar 1/3 de vuelta a cada uno, de este modo se evitarán eventuales desalineamientos.

Después efectuar el desbloqueo total, pero siempre gradual y sin extraer totalmente los tornillos de los filetes.

Se aconseja realizar el eje macho, a acoplar con los grupos Planetary Drives, con una tolerancia h6.

Además, se recomienda seguir las instrucciones indicadas al lado de cada plano.

Redutores para montagem pendular (FS)

Para a instalação destes redutores pre-screve-se a aplicação de um braço de reação que respeite os comprimentos mínimos indicados no desenho para cada unidade.

Além disso, aconselha-se a amortecer o vínculo de reação com elementos de borracha e/ou amortecedores.

No caso de aplicação de motores muito pesados ou de montagem com correia no lado da entrada, entre em contato com o nosso Serviço Técnico Comercial para verificar a instalação.

De fato, nestes casos são produzidas cargas externas que, juntando-se às cargas da transmissão, podem reduzir significativamente a vida dos rolamentos, prejudicar a eficácia de aperto do disco de contração ou ter efeitos negativos na resistência do eixo.

Para garantir um acoplamento eficiente entre o reductor e o equipamento a ser acionado, é preciso remover cuidadosamente toda a graxa da superfície interna do eixo do reductor e do relativo eixo macho de acoplamento.

Para obter um aperto perfeito do disco de contração, recomendamos apertar os parafusos de maneira gradual e uniforme, com seqüência contínua.

Para a remoção é preciso desatarraxar os parafusos gradualmente da mesma maneira como foram atarraxados, ou seja, com seqüência contínua e gradual.

Aconselhamos a desapertar cada parafuso 1/3 de volta na primeira seqüência de afrouxamento para evitar possíveis problemas de alinhamento.

Em seguida, continue desapertando os parafusos sempre gradualmente e sem deixar que eles saiam totalmente das roscas.

É aconselhável realizar o eixo macho a ser acoplado às unidades Planetary Drives com um valor de tolerância h6.

Respeite também as indicações fornecidas ao lado de cada desenho.

LUBRIFICAZIONE

Per il buon funzionamento dei riduttori è indispensabile una corretta lubrificazione.

Si consiglia pertanto di verificare le seguenti condizioni in fase di installazione:

- Controllare che, in relazione alla posizione di montaggio specificata in fase d'ordine, il gruppo abbia i tappi di servizio montati correttamente, secondo le indicazioni del capitolo POSIZIONI DI MONTAGGIO (pag. A-58).
- Quando il gruppo è montato in posizione orizzontale bisogna riempirlo fino alla mezzeria, indipendentemente dalla configurazione lineare o angolare. Controllare visivamente il livello dell'olio svitando il tappo posto sulla stessa zona o in zona limitrofa, vale a dire appena sopra.
- Nel caso di gruppi angolari, la coppia conica è collegata in modo che l'olio possa circolare liberamente; conviene comunque effettuare il riempimento a terra, secondo la corretta posizione di montaggio, introducendo olio da entrambe le parti non contemporaneamente, in modo da snellire l'operazione di riempimento e, nello stesso tempo, avere la certezza di introdurre la quantità di olio necessaria, qualora l'olio impieghi tempo per passare da una camera all'altra.
- Rivolgere particolare attenzione ai gruppi montati in posizione verticale che devono essere completamente riempiti mediante gomiti e prolunghe, di cui è dotato il gruppo. Per queste posizioni è consigliabile l'uso di un vaso di espansione fornito su richiesta, separatamente dal gruppo. Il vaso deve essere posizionato oltre il punto più alto del riduttore ed ha il compito di alloggiare eventuali espansioni di olio o di garantire un rabbocco sicuro per gruppi montati in posizioni inaccessibili.
- I freni e gli attacchi motore assemblati formano una camera separata dal resto del riduttore; bisogna pertanto provvedere al loro riempimento separatamente dal riduttore, vedere capitolo FRENI (pag. D-2).
- I gruppi con servizio continuativo sono soggetti a surriscaldamento per la notevole quantità di olio in essi contenuta: in questi casi consigliamo l'uso di oli con una viscosità più bassa.

LUBRICATION

Correct lubrication is required to run drives efficiently.

Therefore, check the following conditions during installation:

- Make sure that all plugs are correctly mounted with respect to the installation position specified in the order and according to the instructions in the MOUNTING POSITIONS section (page A-58).
- Fill horizontally-mounted units up to the central line regardless of a linear or angular configuration. To visually check the oil level, unscrew the plug located just above the center line.
- For right angle units, the bevel gear is connected so that the oil is free to circulate. In any case, carry out the filling operation on both ends, but not simultaneously, and while the unit is on the ground, based on the correct mounting position. This will speed up the operation and ensure that the correct quantity of oil is introduced, regardless of how long it would take for the oil to go from one chamber to the other.
- Particular attention should be paid to vertically-mounted units which must be completely filled by means of elbows and extensions supplied with the unit. For these positions it is recommended to use an expansion tank, which can be supplied separately on request. This tank must be positioned above the highest point of the drive and is designed to collect any oil expansions or to ensure that the units mounted in hard-to-reach places can be topped up.
- Brakes and assembled motor connections form a separate chamber from the drive and thus must be filled separately - see the BRAKES section (page D-2).
- Units running under continuous duty conditions may overheat due to the large quantity of oil they contain. In these cases, use oil with a lower viscosity.

SCHMIERUNG

Nur eine korrekte Schmierung gewährleistet den problemlosen Betrieb des Getriebes.

Es wird deshalb empfohlen, bei der Installation folgende Bedingungen zu überprüfen:

- Kontrollieren, ob je nach bestellter Montageposition die Einfüllstutzen korrekt montiert sind, vgl. dazu die Angaben im Abschnitt EINBAULAGE (seite A-58).
- Ist das Getriebe waagrecht montiert, muß es bis zur Mitte aufgefüllt werden; Sichtkontrolle des Ölstandes vornehmen, indem der Öleinfüllstopfen abgeschraubt wird.
- Bei Winkelgetrieben ist der rechtwinklige Teil so angebaut, daß das Öl ungehindert zirkulieren kann; es empfiehlt sich jedoch, das Öl am Boden einzufüllen, wobei es auf beiden Seiten geöffnet, aber nicht gleichzeitig eingefüllt wird; der Vorgang wird dadurch beschleunigt und man kann gleichzeitig sicher sein, die erforderliche Ölmenge einzufüllen, da das Öl Zeit braucht, um von einer Kammer in die andere zu fließen.
- Besondere Sorgfalt ist bei Getrieben erforderlich, die senkrecht montiert werden; sie müssen mit Hilfe der beigelegten Kniestücke und Verlängerungen vollständig aufgefüllt werden. Für diese Einbauposition wird die Verwendung eines Ausgleichsbehälter empfohlen, der auf Anfrage separat geliefert wird. Das Gefäß muß oberhalb des höchsten Getriebepunktes positioniert werden und soll überschüssige Ölmengen aufnehmen bzw. bei Getrieben in unzugänglichen Positionen ein sicheres Einfüllen gewährleisten.
- Die montierten Bremsen und Motorschlüsse bilden eine vom restlichen Getriebe - ausführung getrennte Kammer; diese muß deshalb getrennt vom Getriebe aufgefüllt werden, siehe Abschnitt BREMSEN (Seite D-2).
- Außerdem kommt es bei Getrieben, die im Dauerbetrieb arbeiten, aufgrund der darin enthaltenen großen Ölmengen leicht zu Überhitzung; in diesem Fall wird die Verwendung von Öltypen mit niedrigerem Viskositätsgrad empfohlen.

LUBRIFICATION

Une bonne lubrification est indispensable au bon fonctionnement des réducteurs.

Il est par conséquent recommandé de s'assurer des conditions suivantes en cours d'installation:

- En fonction de la position de montage spécifiée lors de la commande, s'assurer que les bouchons de service du groupe sont montés correctement, conformément aux indications du chapitre POSITIONS DE MONTAGE (page A-58).
- Lorsque le groupe est monté en position horizontale, il est nécessaire de le remplir de lubrifiant à mi-hauteur, que la configuration soit linéaire ou angulaire. Contrôler le niveau de lubrifiant visuellement en dévissant le bouchon se trouvant à mi-hauteur ou à proximité, c'est-à-dire juste au-dessus.
- Dans le cas de groupes angulaires, la couple conique est relié de façon à ce que le lubrifiant puisse circuler librement; il convient cependant d'effectuer le remplissage au sol, selon la position exacte de montage, en introduisant le lubrifiant des deux côtés, non simultanément, de façon à faciliter le remplissage et, dans le même temps, d'être certain que la quantité d'huile nécessaire a bien été introduite dans le cas où le lubrifiant mettrait un certain temps pour passer d'une chambre à l'autre.
- Faire particulièrement attention aux groupes montés en position verticale, lesquels doivent être entièrement remplis au moyen de coudes et rallonges dont le groupe est équipé. En ce qui concerne ces positions, il est conseillé d'utiliser un réservoir d'expansion fourni sur demande. Le réservoir doit être placé au-dessus du point le plus haut du réducteur, sa fonction est de permettre aux éventuelles expansions du lubrifiant d'y pénétrer ou bien de garantir une remise à niveau dans le cas de groupes montés dans des positions inaccessibles.
- Les freins et les accouplements au moteur forment une chambre séparée du reste du réducteur; il est par conséquent nécessaire de les remplir séparément du réducteur (voir chapitre FREINS, page D-2).
- Les groupes à fonctionnement en service continu sont sujets des surchauffes en raison de la très grande quantité d'huile qu'ils contiennent: dans ce cas, il est conseillé d'employer des lubrifiants à degré de viscosité inférieur.

LUBRICACIÓN

Para un buen funcionamiento de los reductores es indispensable una correcta lubricación.

Por tanto, se aconseja verificar las siguientes condiciones durante la instalación:

- Controlar que, según la posición de montaje especificada en la orden, el grupo tenga todos los tapones de servicio correctamente montados, según las indicaciones del capítulo POSICIONES DE MONTAJE (Pág. A-58).
- Cuando el grupo esté montado en posición horizontal habrá que llenarlo hasta la línea central, independientemente de la configuración lineal o angular. Controlar visualmente el nivel de aceite aflojando el tapón que está situado en la misma zona o en una zona limítrofe o sea, apenas por encima.
- En el caso de grupos angulares, los engranajes cónicos están conectados de modo tal que el aceite pueda circular libremente; se aconseja introducir el aceite en ambos lados pero no simultáneamente y mientras la unidad esté en el piso, según la correcta posición de montaje. De este modo se hará más rápido el llenado y, al mismo tiempo, se podrá estar seguro que se introdujo la cantidad necesaria de aceite, ya que el aceite emplea un cierto tiempo para pasar de una cámara a otra.
- Prestar una particular atención a los grupos montados en posición vertical pues se tienen que llenar totalmente con tubos acodados y extensiones suministradas junto con el grupo. Para estas posiciones se aconseja utilizar un recipiente de expansión suministrado a pedido, separado del grupo. Dicho recipiente tiene que ubicarse por encima del punto más alto del reductor y cumple la función de absorber las eventuales dilataciones del aceite o de garantizar un llenado seguro en los grupos que se montaron en posiciones inaccesibles.
- Los frenos y las conexiones al motor forman una cámara separada del resto del reductor; por tanto hay que prever su llenado separadamente del reductor, ver el capítulo FRENOS (Pág. D-2).
- Los grupos con servicio continuo pueden recalentarse debido a la gran cantidad de aceite que contienen: en estos casos se aconseja utilizar aceites con una viscosidad más baja.

LUBRIFICAÇÃO

Para obter o bom funcionamento dos reductores, é indispensável proceder a uma lubrificação correta.

Aconselhamos, portanto, a verificar as seguintes condições no momento da instalação:

- Em função da posição de montagem especificada na encomenda, verifique se todos os bujões de serviço estão montados corretamente na unidade, segundo as indicações do capítulo POSIÇÕES DE MONTAGEM (pág. A-58).
- Se a unidade estiver montada na posição horizontal, é preciso enchê-la até a linha central, independentemente da configuração linear ou angular. Controle o nível de óleo visualmente desatarraxando o bujão posto na mesma zona ou numa zona limítrofe, ou seja, imediatamente acima da linha central.
- No caso de unidades angulares, o par cônico é ligado de maneira que o óleo possa circular livremente; de qualquer forma, é conveniente fazer o enchimento no chão, de acordo com a posição de montagem correta, introduzindo o óleo por ambos os lados não simultaneamente para agilizar a operação de enchimento e, ao mesmo tempo, ter a certeza de introduzir a quantidade de óleo necessária, se o mesmo demorar um certo tempo para passar de uma câmara à outra.
- Preste muita atenção nas unidades montadas em posição vertical porque elas devem ser enchidas completamente utilizando os cotovelos e extensões fornecidos com a unidade. Para estas posições é aconselhável utilizar um vaso de expansão fornecido separadamente da unidade, a pedido. O vaso de expansão deve ser colocado acima do ponto mais alto do reductor e serve para receber possíveis expansões de óleo ou para garantir um abastecimento seguro para unidades montadas em posições inacessíveis.
- Os freios e as conexões montadas no motor formam uma câmara separada do resto do reductor; portanto, é preciso enchê-los separadamente do reductor. Consulte o capítulo FREIOS (pág. D-2).
- As unidades com serviço contínuo ficam sujeitas a superaquecimento devido à grande quantidade de óleo nelas contidas: nestes casos, aconselhamos o emprego de óleos com uma viscosidade mais baixa.

I quantitativi di olio indicati nelle tabelle di catalogo, riportate per ogni grandezza, sono puramente indicativi e sono soggetti a variazioni in funzione della configurazione del riduttore: tipo di rapporto, freno, attacco motore e supporto in uscita.

Durante il funzionamento la temperatura delle superfici esterne non deve superare gli 80°C.

Se si verificano temperature superiori contattare il Servizio Tecnico-Commerciale Comer Industries.

CAMBIO OLIO

- Effettuare il primo cambio olio dopo 100 ore di funzionamento.
- I cambi successivi devono avvenire dopo 2000 ore o almeno una volta all'anno.
- Lo svuotamento del riduttore va effettuato con l'olio ancora caldo, per evitare il deposito di morchie.
- Pulire i tappi.
- Prima del riempimento con nuovo olio effettuare un lavaggio interno del gruppo con liquido detergente consigliato dal fornitore di lubrificante.
- Controllare periodicamente che non vi siano perdite d'olio e che, a gruppo fermo, l'olio raggiunga il livello previsto. Se necessario, effettuare un rabbocco con lo stesso tipo di olio presente nel riduttore.
- **Attenzione:** un rabbocco superiore al 10% del quantitativo totale può essere indice di perdita nel riduttore.

SMALTIMENTO OLIO ESAUSTO

Durante le fasi di smaltimento degli oli esausti è obbligatorio utilizzare tutte le cautele e le professionalità necessarie per eseguire il lavoro a regola d'arte, evitando di inquinare suolo, aria, acqua e rispettando l'ambiente e la salute umana.

L'olio esausto, non inquinato da altre sostanze, deve essere raccolto e conferito in apposito centro autorizzato, nel pieno rispetto delle locali legislazioni e normative di tutela ambientale e delle leggi vigenti.

Please note that the oil quantities shown in the catalogue are approximate and may vary depending on the drive configuration: ratio, brake, motor connections and output adapters.

During normal operation, the temperature of the outer casing should not exceed 80°C.

If the temperature exceeds 80°C, contact the Comer Industries Technical-Commercial Service Department.

OIL CHANGES

- The first oil change should be done after 100 hours of duty
- Subsequent oil changes should take place after 2000 hours or at least once a year.
- To avoid sludge deposits, change the oil while the drive is still hot.
- Clean all plugs.
- Before adding the new oil, the unit should be flushed with a liquid detergent recommended by the lubricant supplier.
- Periodically check for oil leaks and the oil level while the unit is idling. If needed, top up using the same type of oil.
- **Attention:** if the quantity of oil used to top up is greater than 10% of the oil capacity, then check again for leaks.

DISPOSING OF EXHAUSTED OIL

When disposing of exhausted oils, it is mandatory to adopt all precautions and professional expertise necessary for carrying out the job in a workmanlike manner so as not to pollute the soil, air and water and treating the environment and human health with care.

Exhausted oil not contaminated by other substances must be collected and delivered to a special authorised centre, in full compliance with local environmental protection laws and regulations and laws in force.

Die in den Tabellen den einzelnen Größen zugeordneten Ölmengen sind Richtwerte, die je nach Getriebeausführung und damit je nach Übersetzung, Bremse, Motorschluß und Ausgangswelle variieren.

Beim Betrieb sollte die Gehäusetemperatur von außen 80°C nicht überschreiten.

Sollten höhere Temperaturen auftreten, wenden Sie sich bitte an den Kundenservice (sales) von SOM.

ÖLWECHSEL

- Der erste Ölwechsel sollte nach 100 Betriebsstunden vorgenommen werden.
- Weitere Ölwechsel sollten nach 2000 Betriebsstunden bzw. mindestens einmal jährlich erfolgen.
- Das Öl bitte bei noch warmen Getriebe ablassen. Auf diese Weise werden Ablagerungen vermieden.
- Ölstopfen reinigen.
- Vor dem Auffüllen mit neuem Öl, das Getriebe innen mit einem vom Schmierstoffhersteller empfohlenen Reinigungsmittel auswaschen.
- Getriebe regelmäßig auf Dichtigkeit prüfen sowie sicherstellen, daß bei Stillstand das Öl bis zum vorgesehenen Ölstand reicht. Sofern erforderlich, ist Öl nachzufüllen; der Öltyp muß mit dem im Getriebe bereits enthaltenen Öl unbedingt übereinstimmen.
- **Achtung:** Eine Nachfüllmenge, die 10% der Gesamtmenge übersteigt, könnte auf eine Undichtigkeit des Getriebes hinweisen.

ALTÖLENTSORGUNG

Bei den Vorgängen zur Altöleentsorgung ist es vorgeschrieben, alle notwendigen Sicherheitsmaßnahmen zu treffen und die Arbeit kunstgerecht durchzuführen, damit Boden, Luft und Wasser nicht verschmutzt und die Umwelt und die Gesundheit des Menschen geschützt werden.

Nicht mit anderen Stoffen verunreinigtes Altöl muss unter Berücksichtigung der örtlichen Umweltschutzgesetze und -vorschriften gesammelt und der speziellen zugelassenen Entsorgungsstelle übergeben werden.

Les quantités d'huile indiquées dans les tableaux du catalogue pour chaque dimensionnement sont purement indicatives et peuvent varier en fonction de la configuration du réducteur: type de rapport, frein, accouplement au moteur et support en sortie.

Pendant le fonctionnement du réducteur, la température de ses surfaces extérieures ne doit pas dépasser 80°C.

En présence de températures supérieures, prendre contact avec le Service Technico-Commercial Comer Industries.

Las cantidades de aceite indicadas en las tablas del catálogo para cada dimensión, son sólo indicativas y pueden variar en función de la configuración del reductor: tipo de relación, freno, conexión al motor y soporte de salida.

Durante el funcionamiento la temperatura de las superficies externas no tiene que superar los 80°C.

Si las temperaturas fueran superiores será necesario ponerse en contacto con el Servicio Técnico-Comercial de Comer Industries.

As quantidades de óleo apresentadas nas tabelas do catálogo, fornecidas para cada tamanho, são puramente indicativas e podem variar em função da configuração do reductor: tipo de relação, freio, acoplamento com o motor e suporte na saída.

Durante o funcionamento, a temperatura das superfícies externas não deve ultrapassar 80°C.

No caso de temperaturas superiores, entre em contato com o Serviço Técnico Comercial da Comer Industries.

VIDANGE D'HUILE

- Faire la première vidange après 100 heures de fonctionnement.
- Exécuter les vidanges suivantes toutes les 2000 heures ou bien au moins une fois par an.
- La vidange du réducteur doit se faire lorsque l'huile est encore chaude de façon à éviter les dépôts de cambouis.
- Nettoyer les bouchons.
- Laver l'intérieur du réducteur avec un détergent conseillé par le fournisseur du lubrifiant avant d'effectuer le remplissage.
- Contrôler périodiquement qu'il n'y ait pas de pertes d'huile et que, lorsque le groupe est arrêté, l'huile atteint bien le niveau prévu.
Si nécessaire, rétablir ce niveau avec de l'huile du même type que celle se trouvant dans le réducteur.
- **Attention:**
une remise à niveau avec plus de 10% de la quantité totale de l'huile contenue dans le réducteur peut être un signe de fuite dans ce dernier.

ÉLIMINATION DES HUILES USÉES

Durant les phases d'élimination des huiles usées, il est impératif de prendre toutes les précautions et les mesures techniques pour opérer dans les règles de l'art et prévenir ainsi la pollution des sols, de l'air et des eaux, pour respecter l'environnement et la santé des personnes.

Les huiles usées, non polluées par d'autres substances, doivent être récupérées et remises à un centre de collecte agréé, dans le respect des dispositions locales et des autres normes de protection de l'environnement, en conformité aux lois en vigueur.

CAMBIO DE ACEITE

- Efectuar el primer cambio de aceite después de las 100 horas de funcionamiento.
- Los cambios sucesivos se deberán realizar después de las 2000 horas o por lo menos una vez al año.
- El vaciado del reductor se tiene que realizar estando todavía el aceite caliente, para evitar el depósito de sedimentos.
- Limpiar los tapones.
- Antes de efectuar el llenado con el aceite nuevo hay que lavar el interior del grupo con el detergente que aconseja el proveedor del lubricante.
- Controlar periódicamente que no haya pérdidas de aceite y que, estando el grupo parado, el aceite alcance el nivel previsto.
Si fuese necesario, efectuar un llenado con el mismo tipo de aceite del reductor.
- **Atención:**
si el llenado supera el 10% de la cantidad total puede ser que haya una pérdida en el reductor.

ELIMINACIÓN DE ACEITE USADO

Durante las fases de eliminación de los aceites usados se requiere ser extremadamente cauteloso y profesional para efectuar correctamente el trabajo, evitando contaminar suelo, aire, agua y respetando el medio ambiente y la salud humana.

El aceite usado, no contaminado con otras sustancias, debe recolectarse y enviarse al centro autorizado correspondiente, respetando las legislaciones y normativas locales de protección del ambiente y leyes vigentes.

TROCA DO ÓLEO

- Faça a primeira troca de óleo após 100 horas de funcionamento.
- As trocas seguintes devem ser feitas após 2000 horas ou pelo menos uma vez por ano.
- Esvazie o reductor com o óleo ainda quente para evitar o depósito de borra.
- Limpe todos os bujões.
- Antes de encher com óleo novo, faça uma lavagem interna da unidade com um líquido detergente aconselhado pelo fornecedor do lubrificante.
- Verifique periodicamente se não há vazamentos de óleo e se, com a unidade parada, o óleo atinge o nível previsto.
Se necessário, complete o nível com o mesmo tipo de óleo presente no reductor.
- **Atenção:**
a necessidade de completar o nível com uma quantidade maior do que 10% da quantidade total pode ser um sintoma de vazamento de óleo no reductor.

DESCARTE DO ÓLEO EXAURIDO

Durante as fases de descarte dos óleos exauridos é obrigatório ter toda a cautela e profissionalismo necessário para realizar o trabalho de acordo à norma, evitando poluir o solo, ar, água e respeitando o meio ambiente e a saúde humana.

O óleo exaurido, não contaminado por outras substâncias, deve ser recolhido e enviado ao centro autorizado, no pleno respeito das legislações e normativas locais de proteção do meio ambiente e das leis vigentes.

Lubrificante

Comer Industries consiglia l'uso di olii per ingranaggi con additivi EP e caratteristiche antischiama. Quando il riduttore è sottoposto ad elevate temperature, si consiglia l'uso di olii a base sintetica.

A tale riguardo le Tabelle N°4 e N°5 riporta alcuni tipi di olii commerciali che rispondono alle caratteristiche richieste in funzione della temperatura ambiente.

Contattare il nostro servizio tecnico commerciale per richiedere informazioni relative a:

- lubrificanti presenti in tabella
- lubrificanti non presenti in tabella
- lubrificanti per uso alimentare
- lubrificanti biologici
- installazioni con temperature ambientali estreme
- viscosità/temperature non in tabella

Lubrifiant

Comer Industries conseille l'utilisation des huiles pour engrenages avec additifs EP et anti-mousse. Lorsque le réducteur est soumis à de hautes températures, il est conseillé d'utiliser des huiles de synthèse.

Le tableau N°4, N°5 indique certains types d'huiles vendues dans le commerce qui correspondent aux caractéristiques requises, en fonction de la température ambiante.

Contactez notre service technique commercial pour demander des informations au sujet de :

- lubrifiants présents dans le tableau
- lubrifiants non présents dans le tableau
- lubrifiants à usage dans le secteur alimentaire
- lubrifiants biologiques
- installations avec des températures ambiantes extrêmes
- viscosités/températures non indiquées dans le tableau

Lubricant

Comer Industries recommends using EP additive oil with anti-foaming properties. If the drive is subjected to high temperatures, use synthetic oil.

With this in mind, Table 4 and Table 5 shows some types of commercially available oils that meet the lubrication requirements in relation to different ambient temperatures.

Contact our technical-commercial service for more information about:

- the lubricants in the table
- the lubricants not in the table
- food-grade lubricants
- biological lubricants
- installations with extreme ambient temperatures
- viscosity/temperatures not in the table

Lubricante

Comer Industries aconseja el uso de aceites para engranajes con aditivos EP con características antiespuma. Cuando el reductor está sometido a elevadas temperaturas, se aconseja el uso de aceites de base sintética.

Para tal fin en la Tabla N° 4, N° 5 se indican algunos tipos de aceites comerciales que cumplen con las características solicitadas en función de la temperatura ambiente.

Contactar con nuestro servicio técnico comercial para solicitar información relativa a:

- lubricantes presentes en la tabla
- lubricantes no presentes en la tabla
- lubricantes para uso alimentario
- lubricantes biológicos
- instalaciones con temperaturas ambientales extremas
- viscosidad/temperaturas no presentes en la tabla

Schmierstoff

Comer Industries empfiehlt Getriebe-Öltypen mit EP- Zusatz und Anti-schaum-Eigenschaft. Ist das Getriebe starken Temperaturschwankungen ausgesetzt, wird die Verwendung von synthetischen Öltypen.

Dazu sind in Tabelle N° 4, N° 5 einige im Handel erhältliche Öltypen aufgeführt, deren Eigenschaften unterschiedlichen Raumtemperaturen angepaßt sind.

Für folgende Informationen bitte unseren technischen/kommerziellen Service kontaktieren:

- In der Tabelle aufgeführte Schmiermittel
- In der Tabelle nicht aufgeführte Schmiermittel
- Schmiermittel im Lebensmittelbereich
- Biologisch abbaubare Schmiermittel
- Anlagen mit extremen Umgebungstemperaturen
- In der Tabelle nicht aufgeführte Viskositäten/Temperaturen

Lubrificante

A Comer Industries aconselha o uso de óleos para engrenagens com aditivos EP e características antiespuma. Quando o reductor for submetido a temperaturas elevadas, aconselha-se o emprego de óleo sintético.

Para o efeito, na Tabela N° 4, N° 5 indicamos alguns tipos de óleos comerciais que apresentam as características exigidas em função da temperatura ambiente.

Contactar o nosso serviço técnico comercial para pedir informações relativas a:

- lubrificantes presentes na tabela
- lubrificantes não presentes na tabela
- lubrificantes para uso alimentar
- lubrificantes biológicos
- instalações com temperaturas ambientais muito elevadas
- viscosidade/temperaturas não na tabela

In generale, i riduttori Planetary Drives vengono forniti privi di lubrificante

Les réducteurs Planetary Drives sont généralement vendus sans lubrifiant.

Generally, Planetary Drives are supplied without lubricant.

En general, los reductores Planetary Drives se suministran sin el lubricante.

HINWEIS: saemtliche Getriebe Planetary Drives werden ohne Oelfüllung ausgeliefert.

Em geral, os redutores Planetary Drives são fornecidos sem lubrificante.

Elenco lubrificanti / List of lubricants / Schmiermittelliste / Liste des lubrifiants / Listado lubricantes / Lista dos lubrificantes

Tabella 4 / Table 4 / Tabelle 4 / Tableau 4 / Tabla 4 / Tabela 4

PRODUTTORE / MANUFACTURER/ HERSTELLER PRODUCTEUR / FABRICANTE / PRODUTOR	Lubrificantí / Lubricant / Schmiermitte / Lubrifiant / Lubricante / Lubrificante		
	Minerale / Mineral / Mineral Minerale / Mineral / Mineral	Sintetico / Synthetic / Synthetik Synthétique / Sintético / Sintético	
		PAO	PG
SHELL	Omala S2G	Omala S4GX	Omala S4 WE
EXXON MOBIL	Mobilgear XMP	Mobil SHC Gear	Glygoyle
KLÜBER	Kluberoil GEM1	Klubersynth GEM 4-N	Klubersynth GH6
AGIP	Blasia	Blasia SX	Blasia S
BP	Energol GR-XP	Energol EPX	Energol SG XP
CASTROL	Alpha SP	Alpha EP	Alpha PG
CHEVRON	Ultra Gear	TegraSynthetic Gear	HiPerSYN
TOTAL	Carter EP	Carter SH	Carter SY

ATTENZIONE:

NON mischiare lubrificanti minerali con lubrificanti sintetici.
NON mischiare lubrificanti con caratteristiche differenti.

ATTENTION:

NE PAS mélanger de lubrifiants minéraux avec des lubrifiants synthétiques.
NE PAS mélanger de lubrifiants ayant des caractéristiques différentes.

ATTENTION:

DO NOT mix mineral lubricants with synthetic lubricants.
DO NOT mix lubricants with different characteristics.

ATENCIÓN:

NO mezclar lubricantes minerales con lubricantes sintéticos.
NO mezclar lubricantes de diferentes características.

ACHTUNG:

KEINE Mineralschmiermittel mit synthetischen Schmiermitteln mischen!
KEINE Schmiermittel mit unterschiedlichen Eigenschaften mischen!

ATENÇÃO:

NÃO misturar lubrificantes minerais com lubrificantes sintéticos.
NÃO misturar lubrificantes com características diferentes.

Caratteristiche lubrificanti in funzione della temperatura ambiente t°C.

Caractéristiques des lubrifiants en fonction de la température ambiante t°C.

Lubricant characteristics according to ambient temperature t°C.

Características lubricantes en función de la temperatura ambiente t°C.

Schmiermitteleigenschaften in Bezug auf die Umgebungstemperatur t°C.

Características lubricantes em função da temperatura ambiente t°C.

Tabella 5 / Table 5 / Tabelle 5 / Tableau 5 / Tabla 5 / Tabela 5

Viscosità Viscosity Viskosität Viscosité Viscosidad Viscosidade	Temp. ambiente / Ambient temp. / Umgebungstemperatur / Temp. ambiente / Temp. ambiente / Temp. ambiente [°C (min ÷ max)]		
	Minerale / Mineral / Mineral Minerale / Mineral / Mineral	Sintetico / Synthetic / Synthetik Synthétique / Sintético / Sintético	
		PAO	PG
ISO VG 150	-10 ÷ +30	-20 ÷ +60	
ISO VG 220	+10 ÷ +45		
ISO VG 320	+30 ÷ +60		

ATTENZIONE:

La viscosità di un lubrificante
• aumenta al diminuire della temperatura (diventa più denso).
• diminuisce all'aumentare della temperatura (diventa più fluido).

ATTENTION:

La viscosité d'un lubrifiant
• Elle augmente lorsque la température diminue (devient plus dense).
• Elle diminue lorsque la température augmente (devient plus fluide).

ATTENTION:

The viscosity of a lubricant
• increases as the temperature drops (it becomes denser).
• decreases as the temperature rises (it becomes more fluid).

ATENCIÓN:

La viscosidad de un lubricante
• Aumenta al disminuir la temperatura (se vuelve más denso).
• Disminuye al aumentar la temperatura (se vuelve más fluido).











ACHTUNG:

Die Viskosität eines Schmiermittels
• Erhöht sich bei Temperaturabnahme (wird dickflüssiger).
• Verringert sich bei Temperaturanstieg (wird dünnflüssiger).

ATENÇÃO:

A viscosidade de um lubrificante
• Aumenta assim que a temperatura diminui (torna-se mais denso).
• Diminui assim que a temperatura aumenta (torna-se mais fluido).

Quantità di lubrificante contenuto nei riduttori [l] Lubricant quantity inside the drives [l] Fuellmenge Getriebschmierung [l]

	M		P		CPC		F		FS	
										
PG 101	0.5	1.0	0.5	1.0	0.8	1.6	0.5	1.0	0.5	1.0
PG 102	0.7	1.4	0.7	1.4	1.0	2.0	0.7	1.4	0.7	1.4
PG 103	0.9	1.8	0.9	1.8	1.2	2.4	0.9	1.8	0.9	1.8
PG 104	1.1	2.2	1.1	2.2	1.4	2.8	1.1	2.2	1.1	2.2
PGA 102	2	4	2	4	2.3	4.6	2.0	4.0	2.0	4.0
PGA 103	2.2	4.4	2.2	4.4	2.5	5.0	2.2	4.4	2.2	4.4
PGA 104	2.4	4.8	2.4	4.8	2.7	5.4	2.4	4.8	2.4	4.8
PG 161	0.6	1.2	0.6	1.2	0.9	1.8	0.6	1.2	0.6	1.2
PG 162	0.8	1.6	0.8	1.6	1.1	2.2	0.8	1.6	0.8	1.6
PG 163	1.0	2.0	1.0	2.0	1.3	2.6	1.0	2.0	1.0	2.0
PG 164	1.2	2.4	1.2	2.4	1.5	3.0	1.2	2.4	1.2	2.4
PGA 162	2.1	4.2	2.1	4.2	2.4	4.8	2.1	4.2	2.1	4.2
PGA 163	2.3	4.6	2.3	4.6	2.6	5.2	2.3	4.6	2.3	4.6
PGA 164	2.5	5.0	2.5	5.0	2.8	5.6	2.5	5.0	2.5	5.0
PG 251	1.0	2.0	1.2	2.4	1.5	3.0	0.8	1.6	1.0	2.0
PG 252	1.3	2.6	1.5	3.0	1.8	3.6	1.1	2.2	1.3	2.6
PG 253	1.5	3.0	1.7	3.4	2.0	4.0	1.3	2.6	1.5	3.0
PG 254	1.7	3.4	1.9	3.8	2.2	4.4	1.5	3.0	1.5	3.0
PGA 252	2.6	5.2	3.8	7.6	3.1	6.2	2.4	4.8	2.6	5.2
PGA 253	2.8	5.6	3.0	6.0	3.3	6.6	2.6	5.2	2.8	5.6
PGA 254	3.0	6.0	3.2	6.4	3.5	7.0	2.8	5.6	3.0	6.0
PG 501	1.1	2.2	1.3	2.6	1.6	3.2	0.9	1.8	1.1	2.2
PG 502	1.5	3.0	1.7	3.4	2.0	4.0	1.3	2.6	1.5	3.0
PG 503	1.8	3.6	2.0	4.0	2.3	4.6	1.6	3.2	1.8	3.6
PG 504	2.0	4.0	2.2	4.4	2.5	5.0	1.8	3.6	2.0	4.0
PGA 502	3.1	6.2	3.3	6.6	3.6	7.2	2.9	5.8	3.1	6.2
PGA 503	3.2	6.4	3.4	6.8	3.7	7.4	3.3	6.6	3.2	6.4
PGA 504	3.3	6.6	3.5	7.0	3.8	7.6	3.1	6.2	3.3	6.6
PG 701	—	—	1.6	3.2	2.4	4.8	1.6	3.2	1.6	3.2
PG 702	—	—	2.0	4.0	2.8	5.6	2.0	4.0	2.0	4.0
PG 703	—	—	2.3	4.6	3.1	6.2	2.3	4.6	2.3	4.6
PG 704	—	—	2.5	5.0	3.3	6.6	2.5	5.0	2.5	5.0
PGA 702	—	—	3.6	7.2	4.4	8.8	3.6	7.2	3.6	7.2
PGA 703	—	—	3.8	7.6	4.6	9.2	3.8	7.6	3.8	7.6
PGA 704	—	—	4.0	8.0	4.8	9.6	4.0	8.0	4.0	8.0
PG 1001	2.4	4.8	—	—	3.6	7.2	2.2	4.4	2.4	4.8
PG 1002	3.1	6.2	—	—	4.3	8.6	2.9	5.8	3.1	6.2
PG 1003	3.5	7.0	—	—	4.7	9.4	3.3	6.6	3.5	7.0
PG 1004	3.8	7.6	—	—	5.0	10.0	3.6	7.2	3.8	7.6
PGA 1002	4.4	8.8	—	—	5.6	11.2	4.2	8.4	4.4	8.8
PGA 1003	5.1	10.2	—	—	6.3	12.6	4.9	9.8	5.1	10.2
PGA 1004	6.5	13.0	—	—	7.7	15.4	5.5	11.0	6.5	13.0

NB. Le quantità di lubrificante riportate sono indicative e vanno controllate in fase di riempimento verificando il livello tramite l'apposito tappo di servizio.











NOTE: The lubricant quantities shown in the table are indicative, but should be verified during the filling operation, checking the level through the service plug.

P.S. Die angegebenen Schmiermittelmengen sind indikativ und sind während der Befüllung anhand der Ölstandstopfen zu ueberpruefen.

Quantité de lubrifiant présente dans les réducteurs [1]

Cantidad de lubricante contenido en los reductores [1]

Quantidade de lubrificante contida nos redutores [1]











	M		P		CPC		F		FS	
										
PG 101	0.5	1.0	0.5	1.0	0.8	1.6	0.5	1.0	0.5	1.0
PG 102	0.7	1.4	0.7	1.4	1.0	2.0	0.7	1.4	0.7	1.4
PG 103	0.9	1.8	0.9	1.8	1.2	2.4	0.9	1.8	0.9	1.8
PG 104	1.1	2.2	1.1	2.2	1.4	2.8	1.1	2.2	1.1	2.2
PGA 102	2	4	2	4	2.3	4.6	2.0	4.0	2.0	4.0
PGA 103	2.2	4.4	2.2	4.4	2.5	5.0	2.2	4.4	2.2	4.4
PGA 104	2.4	4.8	2.4	4.8	2.7	5.4	2.4	4.8	2.4	4.8
PG 161	0.6	1.2	0.6	1.2	0.9	1.8	0.6	1.2	0.6	1.2
PG 162	0.8	1.6	0.8	1.6	1.1	2.2	0.8	1.6	0.8	1.6
PG 163	1.0	2.0	1.0	2.0	1.3	2.6	1.0	2.0	1.0	2.0
PG 164	1.2	2.4	1.2	2.4	1.5	3.0	1.2	2.4	1.2	2.4
PGA 162	2.1	4.2	2.1	4.2	2.4	4.8	2.1	4.2	2.1	4.2
PGA 163	2.3	4.6	2.3	4.6	2.6	5.2	2.3	4.6	2.3	4.6
PGA 164	2.5	5.0	2.5	5.0	2.8	5.6	2.5	5.0	2.5	5.0
PG 251	1.0	2.0	1.2	2.4	1.5	3.0	0.8	1.6	1.0	2.0
PG 252	1.3	2.6	1.5	3.0	1.8	3.6	1.1	2.2	1.3	2.6
PG 253	1.5	3.0	1.7	3.4	2.0	4.0	1.3	2.6	1.5	3.0
PG 254	1.7	3.4	1.9	3.8	2.2	4.4	1.5	3.0	1.5	3.0
PGA 252	2.6	5.2	3.8	7.6	3.1	6.2	2.4	4.8	2.6	5.2
PGA 253	2.8	5.6	3.0	6.0	3.3	6.6	2.6	5.2	2.8	5.6
PGA 254	3.0	6.0	3.2	6.4	3.5	7.0	2.8	5.6	3.0	6.0
PG 501	1.1	2.2	1.3	2.6	1.6	3.2	0.9	1.8	1.1	2.2
PG 502	1.5	3.0	1.7	3.4	2.0	4.0	1.3	2.6	1.5	3.0
PG 503	1.8	3.6	2.0	4.0	2.3	4.6	1.6	3.2	1.8	3.6
PG 504	2.0	4.0	2.2	4.4	2.5	5.0	1.8	3.6	2.0	4.0
PGA 502	3.1	6.2	3.3	6.6	3.6	7.2	2.9	5.8	3.1	6.2
PGA 503	3.2	6.4	3.4	6.8	3.7	7.4	3.3	6.6	3.2	6.4
PGA 504	3.3	6.6	3.5	7.0	3.8	7.6	3.1	6.2	3.3	6.6
PG 701	—	—	1.6	3.2	2.4	4.8	1.6	3.2	1.6	3.2
PG 702	—	—	2.0	4.0	2.8	5.6	2.0	4.0	2.0	4.0
PG 703	—	—	2.3	4.6	3.1	6.2	2.3	4.6	2.3	4.6
PG 704	—	—	2.5	5.0	3.3	6.6	2.5	5.0	2.5	5.0
PGA 702	—	—	3.6	7.2	4.4	8.8	3.6	7.2	3.6	7.2
PGA 703	—	—	3.8	7.6	4.6	9.2	3.8	7.6	3.8	7.6
PGA 704	—	—	4.0	8.0	4.8	9.6	4.0	8.0	4.0	8.0
PG 1001	2.4	4.8	—	—	3.6	7.2	2.2	4.4	2.4	4.8
PG 1002	3.1	6.2	—	—	4.3	8.6	2.9	5.8	3.1	6.2
PG 1003	3.5	7.0	—	—	4.7	9.4	3.3	6.6	3.5	7.0
PG 1004	3.8	7.6	—	—	5.0	10.0	3.6	7.2	3.8	7.6
PGA 1002	4.4	8.8	—	—	5.6	11.2	4.2	8.4	4.4	8.8
PGA 1003	5.1	10.2	—	—	6.3	12.6	4.9	9.8	5.1	10.2
PGA 1004	6.5	13.0	—	—	7.7	15.4	5.5	11.0	6.5	13.0

N.B. Les quantités sont indicatives et doivent être contrôlées en phase de remplissage en vérifiant le niveau par le biais du bouchon de service.

Nota. Las cantidades de lubricante indicadas son aconsejables y se recomienda controlarlas durante el llenado verificando el nivel mediante los respectivos tapones de servicio.

OBS.: as quantidades de lubrificante apresentadas são indicativas e devem ser averiguadas no momento do abastecimento controlando o nível por meio do bujão de serviço correspondente.











Quantita' di lubrificante contenuto nei riduttori [l] Lubricant quantity inside the drives [l] Fuellmenge Getriebschmierung [l]

	M		P		CPC		F		FS	
										
PG 1601	2.6	5.2	4.3	8.6	3.9	7.8	1.9	3.8	2.6	5.2
PG 1602	3.3	6.6	5.0	10.0	4.6	9.2	2.6	5.2	3.3	6.6
PG 1603	3.7	7.4	5.4	10.8	5.0	10.0	3.0	6.0	3.7	7.4
PG 1604	4.0	8.0	5.7	11.4	5.3	10.6	3.3	6.6	4.0	8.0
PGA 1602	4.6	9.2	6.3	12.6	5.9	11.8	3.9	7.8	4.6	9.2
PGA 1603	5.3	10.6	7.0	14.0	6.6	13.2	4.6	9.2	5.3	10.6
PGA 1604	6.5	13.0	7.3	14.6	7.8	15.6	5.8	11.6	6.5	13.0
PG 1802	3.9	7.8	5.6	11.2	5.2	10.4	3.2	6.4	3.9	7.8
PG 1803	4.6	9.2	6.3	12.6	5.9	11.8	3.9	7.8	4.6	9.2
PG 1804	4.9	9.8	6.6	13.2	6.2	12.4	4.2	8.4	4.9	9.8
PGA 1802	5.6	11.2	7.3	14.6	6.9	13.8	4.9	9.8	5.6	11.2
PGA 1803	5.9	11.8	7.6	15.2	7.2	14.4	5.2	10.4	5.9	11.8
PGA 1804	6.6	13.2	8.3	16.6	7.9	15.8	5.9	11.8	6.6	13.2
PG 2501	3.7	7.4	—	—	3.7	7.4	2.9	5.8	2.9	5.8
PG 2502	4.6	9.2	—	—	4.6	9.2	3.8	7.6	3.8	7.6
PG 2503	5.0	10.0	—	—	5.0	10.0	4.2	8.4	4.2	8.4
PG 2504	5.3	10.6	—	—	5.3	10.6	4.5	9.0	4.5	9.0
PGA 2502	9.1	18.2	—	—	9.1	18.2	8.3	16.6	8.3	16.6
PGA 2503	6.6	13.2	—	—	6.6	13.2	5.8	11.6	5.8	11.6
PGA 2504	7.0	14.0	—	—	7.0	14.0	6.2	12.4	6.2	12.4
PG 3002	5.3	10.6	—	—	5.3	10.6	4.5	9.0	4.5	9.0
PG 3003	5.8	11.6	—	—	5.8	11.6	5.0	10.0	5.0	10.0
PG 3004	6.1	12.2	—	—	6.1	12.2	5.3	10.6	5.3	10.6
PGA 3003	10.2	20.4	—	—	10.2	20.4	9.4	18.8	9.4	18.8
PGA3004	8.2	16.4	—	—	8.2	16.4	7.0	14.0	7.0	14.0
PG 3501	4.0	8.0	—	—	4.0	8.0	3.3	6.6	3.3	6.6
PG 3502	5.5	11.0	—	—	5.5	11.0	4.7	9.4	4.7	9.4
PG 3503	6.0	12.0	—	—	6.0	12.0	5.2	10.4	5.2	10.4
PG 3504	6.3	12.6	—	—	6.3	12.6	5.5	11.0	5.5	11.0
PGA 3502	6.7	13.4	—	—	6.7	13.4	5.8	11.6	5.8	11.6
PGA 3503	10.2	20.4	—	—	10.2	20.4	9.4	18.8	9.4	18.8
PGA 3504	8.2	16.4	—	—	8.2	16.4	7.0	14.0	7.0	14.0
PG 5001	5.2	10.4	—	—	5.2	10.4	4.5	9.0	4.5	9.0
PG 5002	6.5	13.0	—	—	6.5	13.0	5.8	11.6	5.8	11.6
PG 5003	7.1	14.2	—	—	7.1	14.2	6.4	12.8	6.4	12.8
PG 5004	7.5	15.0	—	—	7.5	15.0	6.9	13.8	6.9	13.8
PGA5002	11.0	22.0	—	—	11.0	22.0	10.3	20.6	10.3	20.6
PGA 5003	8.5	17.0	—	—	8.5	17.0	7.8	15.6	7.8	15.6
PGA 5004	9.1	18.2	—	—	9.1	18.2	8.4	16.8	8.4	16.8
PG 6501	7.2	14.4	—	—	7.2	14.4	6.2	12.4	6.2	12.4
PG 6502	8.5	17.0	—	—	8.5	17.0	7.5	15.0	7.5	15.0
PG 6503	9.7	19.4	—	—	9.7	19.4	8.7	17.4	8.7	17.4
PG 6504	10.1	20.2	—	—	10.1	20.2	9.1	18.2	9.1	18.2
PGA 6503	14.2	28.4	—	—	14.2	28.4	13.2	26.4	13.2	26.4
PGA 6504	11.7	23.4	—	—	11.7	23.4	10.7	21.4	10.7	21.4
PG 9001	8.7	17.4	—	—	8.7	17.4	8.7	17.4	8.7	17.4
PG 9002	10.0	20.0	—	—	10.0	20.0	10.0	20.0	10.0	20.0
PG 9003	11.2	22.4	—	—	11.2	22.4	11.2	22.4	11.2	22.4
PG 9004	11.6	23.2	—	—	11.6	23.2	11.6	23.2	11.6	23.2
PGA 9003	15.7	31.4	—	—	15.7	31.4	15.7	31.4	15.7	31.4
PGA 9004	13.2	26.4	—	—	13.2	26.4	13.2	26.4	13.2	26.4













Quantité de lubrifiant présente dans les réducteurs [1]

Cantidad de lubricante contenido en los reductores [1]

Quantidade de lubrificante contida nos redutores [1]

	M		P		CPC		F		FS	
										
PG 1601	2.6	5.2	4.3	8.6	3.9	7.8	1.9	3.8	2.6	5.2
PG 1602	3.3	6.6	5.0	10.0	4.6	9.2	2.6	5.2	3.3	6.6
PG 1603	3.7	7.4	5.4	10.8	5.0	10.0	3.0	6.0	3.7	7.4
PG 1604	4.0	8.0	5.7	11.4	5.3	10.6	3.3	6.6	4.0	8.0
PGA 1602	4.6	9.2	6.3	12.6	5.9	11.8	3.9	7.8	4.6	9.2
PGA 1603	5.3	10.6	7.0	14.0	6.6	13.2	4.6	9.2	5.3	10.6
PGA 1604	6.5	13.0	7.3	14.6	7.8	15.6	5.8	11.6	6.5	13.0
PG 1802	3.9	7.8	5.6	11.2	5.2	10.4	3.2	6.4	3.9	7.8
PG 1803	4.6	9.2	6.3	12.6	5.9	11.8	3.9	7.8	4.6	9.2
PG 1804	4.9	9.8	6.6	13.2	6.2	12.4	4.2	8.4	4.9	9.8
PGA 1802	5.6	11.2	7.3	14.6	6.9	13.8	4.9	9.8	5.6	11.2
PGA 1803	5.9	11.8	7.6	15.2	7.2	14.4	5.2	10.4	5.9	11.8
PGA 1804	6.6	13.2	8.3	16.6	7.9	15.8	5.9	11.8	6.6	13.2
PG 2501	3.7	7.4	—	—	3.7	7.4	2.9	5.8	2.9	5.8
PG 2502	4.6	9.2	—	—	4.6	9.2	3.8	7.6	3.8	7.6
PG 2503	5.0	10.0	—	—	5.0	10.0	4.2	8.4	4.2	8.4
PG 2504	5.3	10.6	—	—	5.3	10.6	4.5	9.0	4.5	9.0
PGA 2502	9.1	18.2	—	—	9.1	18.2	8.3	16.6	8.3	16.6
PGA 2503	6.6	13.2	—	—	6.6	13.2	5.8	11.6	5.8	11.6
PGA 2504	7.0	14.0	—	—	7.0	14.0	6.2	12.4	6.2	12.4
PG 3002	5.3	10.6	—	—	5.3	10.6	4.5	9.0	4.5	9.0
PG 3003	5.8	11.6	—	—	5.8	11.6	5.0	10.0	5.0	10.0
PG 3004	6.1	12.2	—	—	6.1	12.2	5.3	10.6	5.3	10.6
PGA 3003	10.2	20.4	—	—	10.2	20.4	9.4	18.8	9.4	18.8
PGA3004	8.2	16.4	—	—	8.2	16.4	7.0	14.0	7.0	14.0
PG 3501	4.0	8.0	—	—	4.0	8.0	3.3	6.6	3.3	6.6
PG 3502	5.5	11.0	—	—	5.5	11.0	4.7	9.4	4.7	9.4
PG 3503	6.0	12.0	—	—	6.0	12.0	5.2	10.4	5.2	10.4
PG 3504	6.3	12.6	—	—	6.3	12.6	5.5	11.0	5.5	11.0
PGA 3502	6.7	13.4	—	—	6.7	13.4	5.8	11.6	5.8	11.6
PGA 3503	10.2	20.4	—	—	10.2	20.4	9.4	18.8	9.4	18.8
PGA 3504	8.2	16.4	—	—	8.2	16.4	7.0	14.0	7.0	14.0
PG 5001	5.2	10.4	—	—	5.2	10.4	4.5	9.0	4.5	9.0
PG 5002	6.5	13.0	—	—	6.5	13.0	5.8	11.6	5.8	11.6
PG 5003	7.1	14.2	—	—	7.1	14.2	6.4	12.8	6.4	12.8
PG 5004	7.5	15.0	—	—	7.5	15.0	6.9	13.8	6.9	13.8
PGA5002	11.0	22.0	—	—	11.0	22.0	10.3	20.6	10.3	20.6
PGA 5003	8.5	17.0	—	—	8.5	17.0	7.8	15.6	7.8	15.6
PGA 5004	9.1	18.2	—	—	9.1	18.2	8.4	16.8	8.4	16.8
PG 6501	7.2	14.4	—	—	7.2	14.4	6.2	12.4	6.2	12.4
PG 6502	8.5	17.0	—	—	8.5	17.0	7.5	15.0	7.5	15.0
PG 6503	9.7	19.4	—	—	9.7	19.4	8.7	17.4	8.7	17.4
PG 6504	10.1	20.2	—	—	10.1	20.2	9.1	18.2	9.1	18.2
PGA 6503	14.2	28.4	—	—	14.2	28.4	13.2	26.4	13.2	26.4
PGA 6504	11.7	23.4	—	—	11.7	23.4	10.7	21.4	10.7	21.4
PG 9001	8.7	17.4	—	—	8.7	17.4	8.7	17.4	8.7	17.4
PG 9002	10.0	20.0	—	—	10.0	20.0	10.0	20.0	10.0	20.0
PG 9003	11.2	22.4	—	—	11.2	22.4	11.2	22.4	11.2	22.4
PG 9004	11.6	23.2	—	—	11.6	23.2	11.6	23.2	11.6	23.2
PGA 9003	15.7	31.4	—	—	15.7	31.4	15.7	31.4	15.7	31.4
PGA 9004	13.2	26.4	—	—	13.2	26.4	13.2	26.4	13.2	26.4











Quantita' di lubrificante contenuto nei riduttori [l] Lubricant quantity inside the drives [l] Fuellmenge Getriebschmierung [l]

	M				P		CPC		F		FS					
																
		H		H					H	H	H	H				
PG 12001	13.5	-	-	-	-	-	-	-	14.3	-	-	14.3	-	-	-	
PG 12002	14.9	-	29.8	-	-	-	-	-	15.7	-	31.4	-	15.7	-	31.4	-
PG 12003	16.1	-	32.2	-	-	-	-	-	16.9	-	33.8	-	16.9	-	33.8	-
PG 12004	16.6	-	33.2	-	-	-	-	-	17.4	-	34.8	-	17.4	-	34.8	-
PG 12005	16.9	-	33.8	-	-	-	-	-	17.7	-	35.4	-	17.7	-	35.4	-
PGA 12003	17.9	-	35.8	-	-	-	-	-	18.7	-	37.4	-	18.7	-	37.4	-
PGA 12004	19.1	-	38.2	-	-	-	-	-	19.9	-	39.8	-	19.9	-	39.8	-
PGA 12005	18.6	-	37.2	-	-	-	-	-	19.4	-	38.8	-	19.4	-	38.8	-
PG 16001	14.5	-	-	-	-	-	-	-	14.5	-	29	-	14.5	-	29	-
PG 16002	16.9	-	33.8	-	-	-	-	-	16.9	-	33.8	-	16.9	-	33.8	-
PG 16003	18.3	-	36.6	-	-	-	-	-	18.3	-	36.6	-	18.3	-	36.6	-
PG 16004	18.8	-	37.6	-	-	-	-	-	18.8	-	37.6	-	18.8	-	37.6	-
PG 16005	19.1	-	38.2	-	-	-	-	-	19.1	-	38.2	-	19.1	-	38.2	-
PGA 16003	19.9	-	39.8	-	-	-	-	-	19.9	-	39.8	-	19.9	-	39.8	-
PGA 16004	21.3	-	42.6	-	-	-	-	-	21.3	-	42.6	-	21.3	-	42.6	-
PGA 16005	20.8	-	41.6	-	-	-	-	-	20.8	-	41.6	-	20.8	-	41.6	-
PG 21001	21	-	42	-	-	-	-	-	21	-	42	-	21	-	42	-
PG 21002	23.4	24.9	46.8	49.8	-	-	-	-	23.4	24.9	46.8	49.8	23.4	24.9	46.8	49.8
PG 21003	24.8	27.2	49.6	54.4	-	-	-	-	24.8	27.2	49.6	54.4	24.8	27.2	49.6	54.4
PG 21004	25.3	28.3	50.6	56.6	-	-	-	-	25.3	28.3	50.6	56.6	25.3	28.3	50.6	56.6
PG 21005	25.6	28.9	51.2	57.8	-	-	-	-	25.6	28.9	51.2	57.8	25.6	28.9	51.2	57.8
PGA 21003	26.4	-	52.8	-	-	-	-	-	26.4	-	52.8	-	26.4	-	52.8	-
PGA 21004	27.8	30.2	55.6	60.4	-	-	-	-	27.8	30.2	55.6	60.4	27.8	30.2	55.6	60.4
PGA 21005	27.3	30.3	54.6	60.6	-	-	-	-	27.3	30.3	54.6	60.6	27.3	30.3	54.6	60.6
PG 26001	20	-	40	-	-	-	-	-	20	-	40	-	20	-	40	-
PG 26002	25.2	-	50.4	-	-	-	-	-	25.2	-	50.4	-	25.2	-	50.4	-
PG 26003	26.6	-	53.2	-	-	-	-	-	26.6	-	53.2	-	26.6	-	53.2	-
PG 26004	27.5	-	55	-	-	-	-	-	27.5	-	55	-	27.5	-	55	-
PG 26005	27.9	-	55.8	-	-	-	-	-	27.9	-	55.8	-	27.9	-	55.8	-
PGA 26004	29.6	-	59.2	-	-	-	-	-	29.6	-	59.2	-	29.6	-	59.2	-
PGA 26005	29.5	-	59	-	-	-	-	-	29.5	-	59	-	29.5	-	59	-
PG 31001	42	-	84	-	-	-	-	-	42	-	84	-	42	-	84	-
PG 31002	46.5	50.4	93	100.8	-	-	-	-	46.5	50.4	93	100.8	46.5	50.4	93	100.8
PG 31003	47.9	51.8	95.8	103.6	-	-	-	-	47.9	51.8	95.8	103.6	47.9	51.8	95.8	103.6
PG 31004	48.7	53	97.4	106	-	-	-	-	48.7	53	97.4	106	48.7	53	97.4	106
PG 31005	49.1	53.5	98.2	107	-	-	-	-	49.1	53.5	98.2	107	49.1	53.5	98.2	107
PGA 31004	50.9	53.4	101.8	106.8	-	-	-	-	50.9	53.4	101.8	106.8	50.9	53.4	101.8	106.8
PGA 31005	50.7	54.8	101.4	109.6	-	-	-	-	50.7	54.8	101.4	109.6	50.7	54.8	101.4	109.6
PG 40001	44	-	88	-	-	-	-	-	44	-	88	-	44	-	88	-
PG 40002	49	-	98	-	-	-	-	-	49	-	98	-	49	-	98	-
PG 40003	50.4	-	100.8	-	-	-	-	-	50.4	-	100.8	-	50.4	-	100.8	-
PG 40004	51.3	-	102.6	-	-	-	-	-	51.3	-	102.6	-	51.3	-	102.6	-
PG 40005	51.7	-	103.4	-	-	-	-	-	51.7	-	103.4	-	51.7	-	103.4	-
PGA 40005	54.3	-	108.6	-	-	-	-	-	54.3	-	108.6	-	54.3	-	108.6	-
PG 45001	44	-	88	-	-	-	-	-	44	-	88	-	44	-	88	-
PG 45002	50	-	100	-	-	-	-	-	50	-	100	-	50	-	100	-
PG 45003	52.4	-	104.8	-	-	-	-	-	52.4	-	104.8	-	52.4	-	104.8	-
PG 45004	53.8	-	107.6	-	-	-	-	-	53.8	-	107.6	-	53.8	-	107.6	-
PG 45005	54.3	-	108.6	-	-	-	-	-	54.3	-	108.6	-	54.3	-	108.6	-
PGA 45005	56.8	-	113.6	-	-	-	-	-	56.8	-	113.6	-	56.8	-	113.6	-
PG 53001	70	-	140	-	-	-	-	-	70	-	140	-	70	-	140	-
PG 53002	80	-	160	-	-	-	-	-	80	-	160	-	80	-	160	-
PG 53003	82.4	-	164.8	-	-	-	-	-	82.4	-	164.8	-	82.4	-	164.8	-
PG 53004	83.8	-	167.6	-	-	-	-	-	83.8	-	167.6	-	83.8	-	167.6	-
PG 53005	84.3	-	168.6	-	-	-	-	-	84.3	-	168.6	-	84.3	-	168.6	-
PGA 53005	86.8	-	173.6	-	-	-	-	-	86.8	-	173.6	-	86.8	-	173.6	-
PG 61001	67	-	134	-	-	-	-	-	67	-	134	-	67	-	134	-
PG 61002	77	-	154	-	-	-	-	-	77	-	154	-	77	-	154	-
PG 61003	79.4	-	158.8	-	-	-	-	-	79.4	-	158.8	-	79.4	-	158.8	-
PG 61004	80.8	-	161.6	-	-	-	-	-	80.8	-	161.6	-	80.8	-	161.6	-
PG 61005	81.3	-	162.6	-	-	-	-	-	81.3	-	162.6	-	81.3	-	162.6	-
PGA 61005	83.8	-	167.6	-	-	-	-	-	83.8	-	167.6	-	83.8	-	167.6	-

Quantité de lubrifiant présente dans les réducteurs [1]

Cantidad de lubricante contenido en los reductores [1]

Quantidade de lubrificante contida nos redutores [1]

	M				P		CPC		F		FS					
																
	H	H	H	H	H	H	H	H	H	H						
PG 12001	13.5	-	-	-	-	-	-	-	14.3	-	-	14.3	-	-		
PG 12002	14.9	-	29.8	-	-	-	-	-	15.7	-	31.4	-	15.7	-	31.4	-
PG 12003	16.1	-	32.2	-	-	-	-	-	16.9	-	33.8	-	16.9	-	33.8	-
PG 12004	16.6	-	33.2	-	-	-	-	-	17.4	-	34.8	-	17.4	-	34.8	-
PG 12005	16.9	-	33.8	-	-	-	-	-	17.7	-	35.4	-	17.7	-	35.4	-
PGA 12003	17.9	-	35.8	-	-	-	-	-	18.7	-	37.4	-	18.7	-	37.4	-
PGA 12004	19.1	-	38.2	-	-	-	-	-	19.9	-	39.8	-	19.9	-	39.8	-
PGA 12005	18.6	-	37.2	-	-	-	-	-	19.4	-	38.8	-	19.4	-	38.8	-
PG 16001	14.5	-	-	-	-	-	-	-	14.5	-	29	-	14.5	-	29	-
PG 16002	16.9	-	33.8	-	-	-	-	-	16.9	-	33.8	-	16.9	-	33.8	-
PG 16003	18.3	-	36.6	-	-	-	-	-	18.3	-	36.6	-	18.3	-	36.6	-
PG 16004	18.8	-	37.6	-	-	-	-	-	18.8	-	37.6	-	18.8	-	37.6	-
PG 16005	19.1	-	38.2	-	-	-	-	-	19.1	-	38.2	-	19.1	-	38.2	-
PGA 16003	19.9	-	39.8	-	-	-	-	-	19.9	-	39.8	-	19.9	-	39.8	-
PGA 16004	21.3	-	42.6	-	-	-	-	-	21.3	-	42.6	-	21.3	-	42.6	-
PGA 16005	20.8	-	41.6	-	-	-	-	-	20.8	-	41.6	-	20.8	-	41.6	-
PG 21001	21	-	42	-	-	-	-	-	21	-	42	-	21	-	42	-
PG 21002	23.4	24.9	46.8	49.8	-	-	-	-	23.4	24.9	46.8	49.8	23.4	24.9	46.8	49.8
PG 21003	24.8	27.2	49.6	54.4	-	-	-	-	24.8	27.2	49.6	54.4	24.8	27.2	49.6	54.4
PG 21004	25.3	28.3	50.6	56.6	-	-	-	-	25.3	28.3	50.6	56.6	25.3	28.3	50.6	56.6
PG 21005	25.6	28.9	51.2	57.8	-	-	-	-	25.6	28.9	51.2	57.8	25.6	28.9	51.2	57.8
PGA 21003	26.4	-	52.8	-	-	-	-	-	26.4	-	52.8	-	26.4	-	52.8	-
PGA 21004	27.8	30.2	55.6	60.4	-	-	-	-	27.8	30.2	55.6	60.4	27.8	30.2	55.6	60.4
PGA 21005	27.3	30.3	54.6	60.6	-	-	-	-	27.3	30.3	54.6	60.6	27.3	30.3	54.6	60.6
PG 26001	20	-	40	-	-	-	-	-	20	-	40	-	20	-	40	-
PG 26002	25.2	-	50.4	-	-	-	-	-	25.2	-	50.4	-	25.2	-	50.4	-
PG 26003	26.6	-	53.2	-	-	-	-	-	26.6	-	53.2	-	26.6	-	53.2	-
PG 26004	27.5	-	55	-	-	-	-	-	27.5	-	55	-	27.5	-	55	-
PG 26005	27.9	-	55.8	-	-	-	-	-	27.9	-	55.8	-	27.9	-	55.8	-
PGA 26004	29.6	-	59.2	-	-	-	-	-	29.6	-	59.2	-	29.6	-	59.2	-
PGA 26005	29.5	-	59	-	-	-	-	-	29.5	-	59	-	29.5	-	59	-
PG 31001	42	-	84	-	-	-	-	-	42	-	84	-	42	-	84	-
PG 31002	46.5	50.4	93	100.8	-	-	-	-	46.5	50.4	93	100.8	46.5	50.4	93	100.8
PG 31003	47.9	51.8	95.8	103.6	-	-	-	-	47.9	51.8	95.8	103.6	47.9	51.8	95.8	103.6
PG 31004	48.7	53	97.4	106	-	-	-	-	48.7	53	97.4	106	48.7	53	97.4	106
PG 31005	49.1	53.5	98.2	107	-	-	-	-	49.1	53.5	98.2	107	49.1	53.5	98.2	107
PGA 31004	50.9	53.4	101.8	106.8	-	-	-	-	50.9	53.4	101.8	106.8	50.9	53.4	101.8	106.8
PGA 31005	50.7	54.8	101.4	109.6	-	-	-	-	50.7	54.8	101.4	109.6	50.7	54.8	101.4	109.6
PG 40001	44	-	88	-	-	-	-	-	44	-	88	-	44	-	88	-
PG 40002	49	-	98	-	-	-	-	-	49	-	98	-	49	-	98	-
PG 40003	50.4	-	100.8	-	-	-	-	-	50.4	-	100.8	-	50.4	-	100.8	-
PG 40004	51.3	-	102.6	-	-	-	-	-	51.3	-	102.6	-	51.3	-	102.6	-
PG 40005	51.7	-	103.4	-	-	-	-	-	51.7	-	103.4	-	51.7	-	103.4	-
PGA 40005	54.3	-	108.6	-	-	-	-	-	54.3	-	108.6	-	54.3	-	108.6	-
PG 45001	44	-	88	-	-	-	-	-	44	-	88	-	44	-	88	-
PG 45002	50	-	100	-	-	-	-	-	50	-	100	-	50	-	100	-
PG 45003	52.4	-	104.8	-	-	-	-	-	52.4	-	104.8	-	52.4	-	104.8	-
PG 45004	53.8	-	107.6	-	-	-	-	-	53.8	-	107.6	-	53.8	-	107.6	-
PG 45005	54.3	-	108.6	-	-	-	-	-	54.3	-	108.6	-	54.3	-	108.6	-
PGA 45005	56.8	-	113.6	-	-	-	-	-	56.8	-	113.6	-	56.8	-	113.6	-
PG 53001	70	-	140	-	-	-	-	-	70	-	140	-	70	-	140	-
PG 53002	80	-	160	-	-	-	-	-	80	-	160	-	80	-	160	-
PG 53003	82.4	-	164.8	-	-	-	-	-	82.4	-	164.8	-	82.4	-	164.8	-
PG 53004	83.8	-	167.6	-	-	-	-	-	83.8	-	167.6	-	83.8	-	167.6	-
PG 53005	84.3	-	168.6	-	-	-	-	-	84.3	-	168.6	-	84.3	-	168.6	-
PGA 53005	86.8	-	173.6	-	-	-	-	-	86.8	-	173.6	-	86.8	-	173.6	-
PG 61001	67	-	134	-	-	-	-	-	67	-	134	-	67	-	134	-
PG 61002	77	-	154	-	-	-	-	-	77	-	154	-	77	-	154	-
PG 61003	79.4	-	158.8	-	-	-	-	-	79.4	-	158.8	-	79.4	-	158.8	-
PG 61004	80.8	-	161.6	-	-	-	-	-	80.8	-	161.6	-	80.8	-	161.6	-
PG 61005	81.3	-	162.6	-	-	-	-	-	81.3	-	162.6	-	81.3	-	162.6	-
PGA 61005	83.8	-	167.6	-	-	-	-	-	83.8	-	167.6	-	83.8	-	167.6	-

Vaso di espansione

Per applicazioni dove vengono considerate posizioni di montaggio verticali si consiglia l'utilizzo di un vaso di espansione che permette di alloggiare eventuali espansioni di olio o di garantire un rabbocco in posizioni inaccessibili. Tale accessorio può essere fornito su richiesta.

Expansion tank

For vertical applications, it is recommended to use an expansion tank that can absorb any oil expansions and/or ensure topping up in hard-to-reach places. This fitting can be supplied on request.

Ausgleichsbehälter

Fuer die vertikalen Einbaupositionen ist die Ausruestung mit einem Oelausgleichsbehälter zu empfehlen. Dadurch ist gegeben, dass eventuelle Oeluebertritte vermieden und eine einfache Befuellung ermoglicht wird. Der Behälter ist auf Nachfrage lieferbar.

Spurgo aria e livello olio effettivo nel riduttore
Air drain and oil level in the drive
Entlüften und Ölstand

Carico e sfiato
Filling and breathing
Einfüllen und Entlüften

Livello
Level
Ölstand

246

ø 102

Vaso di espansione
Expansion tank
Ausgleichsbehälter

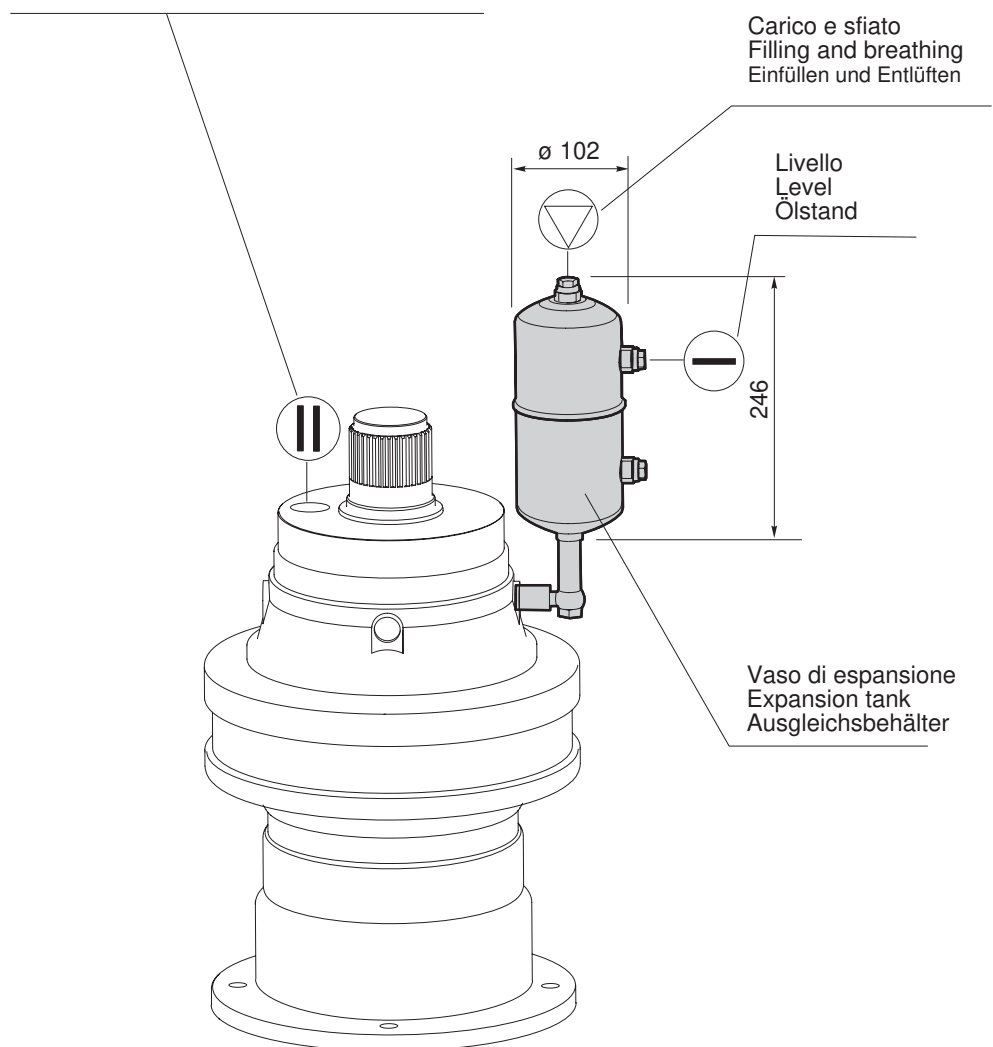
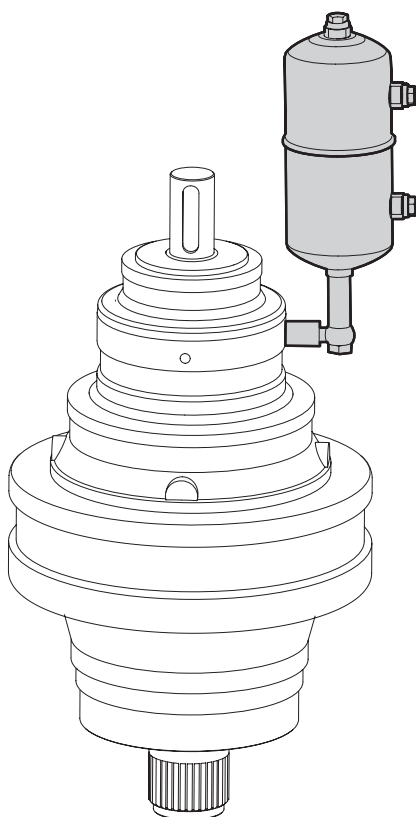

Vase d'expansion

Pour les applications prévoyant des positions de montage verticales, il est recommandé d'utiliser un vase d'expansion qui permet une éventuelle expansion de l'huile ou qui garantit un remplissage dans des positions inaccessibles. Cet accessoire peut être fourni sur demande.

Recipiente de expansión

Para las aplicaciones donde se prevén posiciones verticales de montaje, se aconseja la utilización de un recipiente de expansión que permita absorber las eventuales dilataciones del aceite y/o garantizar un llenado en posiciones inaccesibles. Dicho accesorio se puede suministrar a pedido.

Vase d'expansion

Para aplicações com posições de montagem verticais, aconselha-se a utilização de um vaso de expansão que serve para receber possíveis expansões de óleo ou garantir o abastecimento em posições inacessíveis. Este acessório pode ser fornecido a pedido.

INTR.

Purge air et niveau d'huile effectif dans le réducteur
Purgado del aire y nivel efectivo de aceite en el reductor
Purga do ar e nível efetivo de óleo no redutor

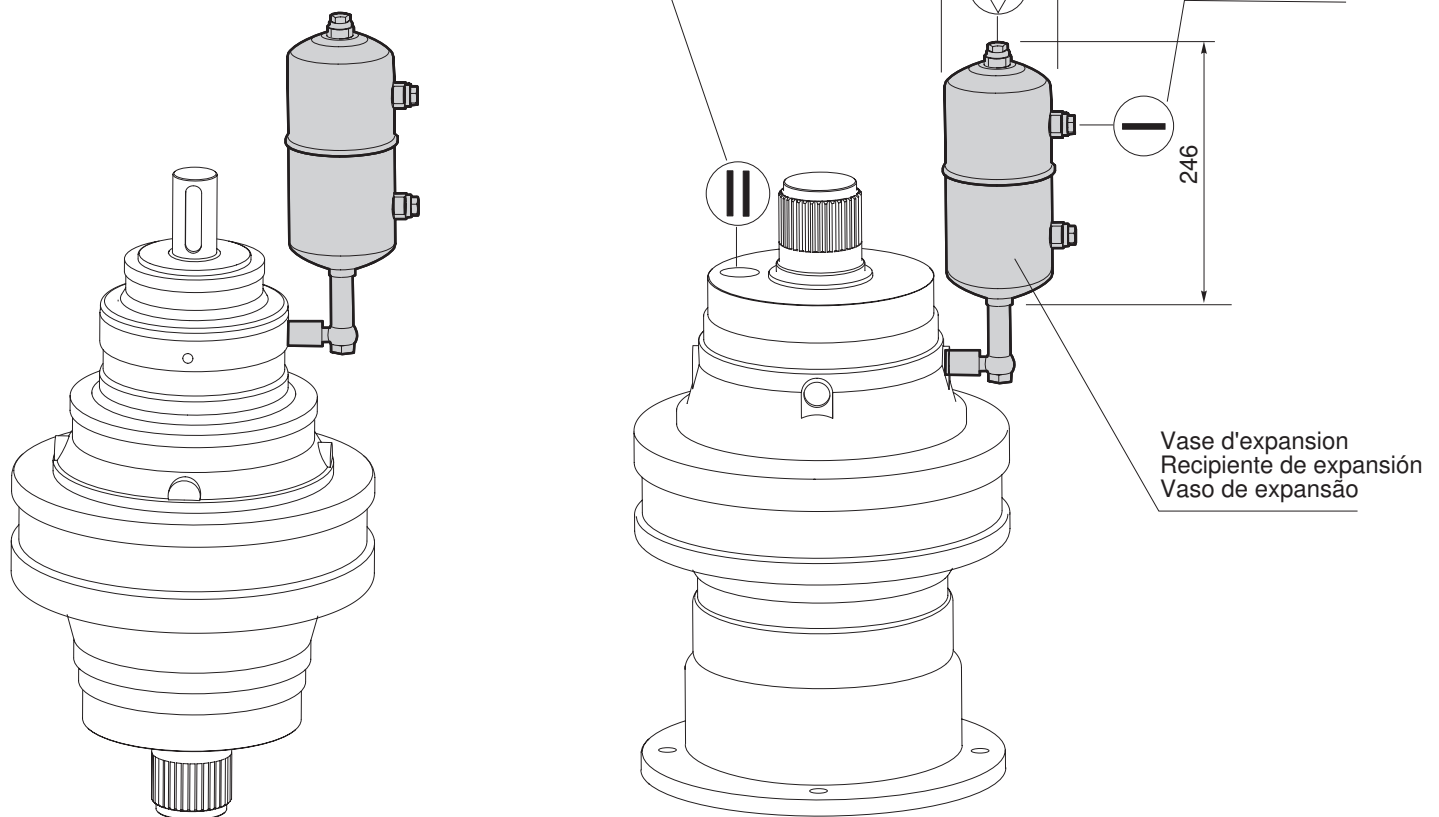

Posizioni di montaggio / Mounting positions / Einbauposition / Positions de montage / Posiciones de montaje / Posições de montagem

M-P

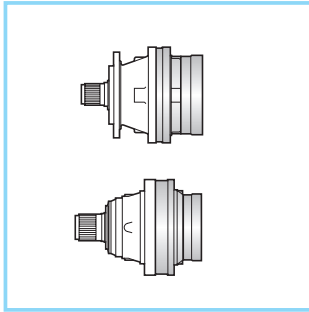

B5

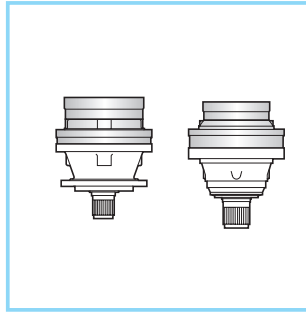

V1

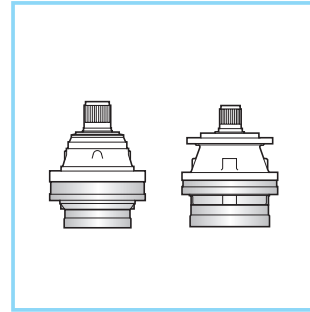

V3

F

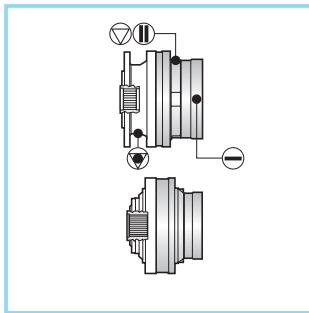

B5

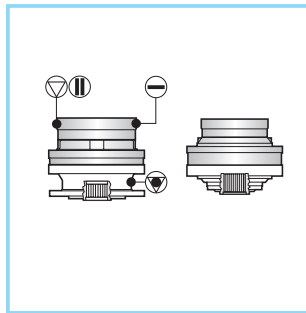

V1

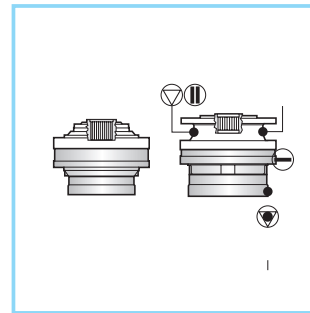

V3

FS

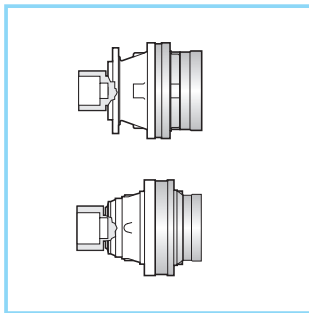

B5

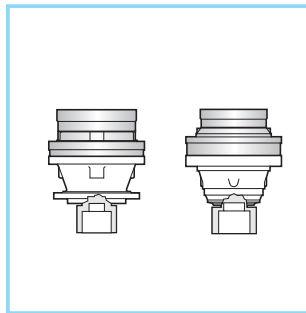

V1

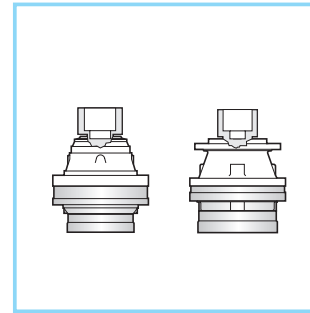

V3

CPC

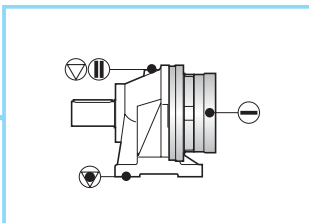

B3

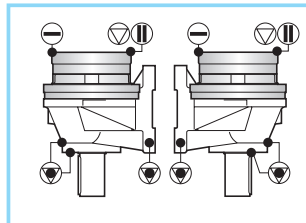

V2

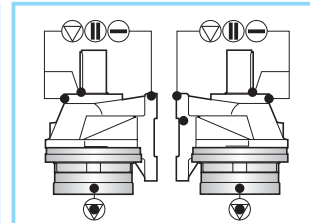

V4

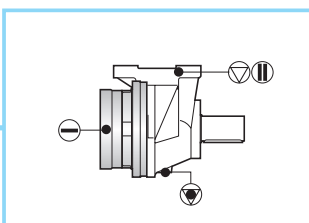

B4

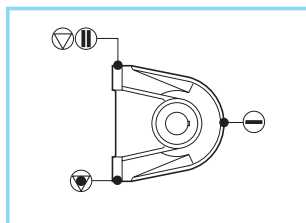

B6

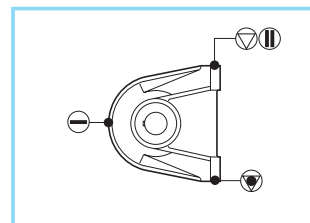

B7

Tappi olio
Oil plugs
Ölstopfen
Bouchons huile
Tapón de aceite
Bujão de óleo

II Tappo sfiato
Vent plug
Entlüftungstopfen
Bouchon à évent
Tapón de venteo
Bujão de respiro

V Tappo carico
Filling plug
Einfüllstopfen
Bouchon remplissage
Tapón de carga
Bujão de enchimento

— Tappo livello
Level plug
Ölstandstopfen
Bouchon jauge
Tapón de nivel
Bujão de nível

▽ Tappo scarico
Drain plug
Ablasstopfen
Bouchon vidange
Tapón de descarga
Bujão de descarga

N.B.

L'orientamento della foratura della flangia di fissaggio è come illustrato nelle schede dei dati dimensionali dei riduttori.

The mounting flange orientation is shown in each planetary gears technical sheets.

Die Ausführung der Befestigungsvorrichtung (Flansch, Bohrung) ist in den Datenblättern der Getriebe ersichtlich.

L'orientation de la flasque de montage est indiquée dans chaque fiche technique réducteur.

La orientación del perforado de la brida de fijación se ilustra en las fichas de los datos dimensionales de los reductores.

A orientação da furação do flange de fixação é a ilustrada nas fichas de dados técnicos dimensionais dos reductores.

Posizioni di montaggio / Mounting positions / Einbauposition / Positions de montage / Posiciones de montaje / Posições de montagem

INTR.

M-P

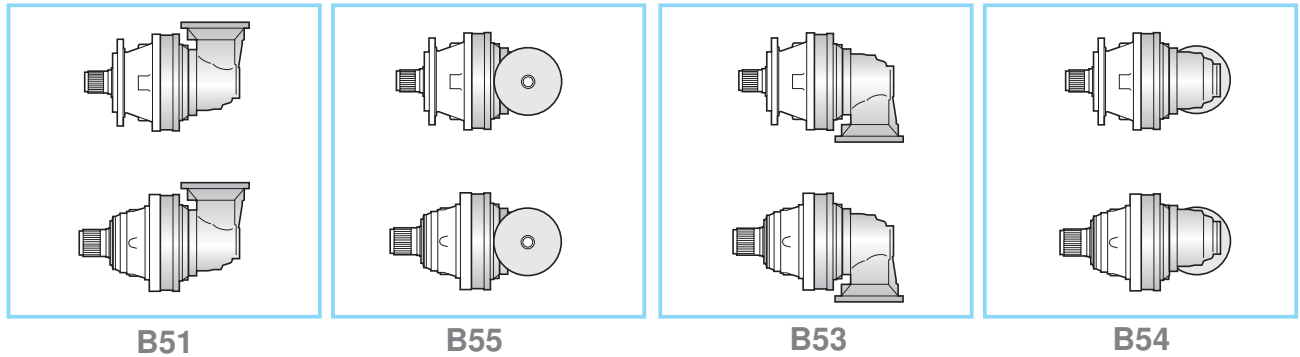

F

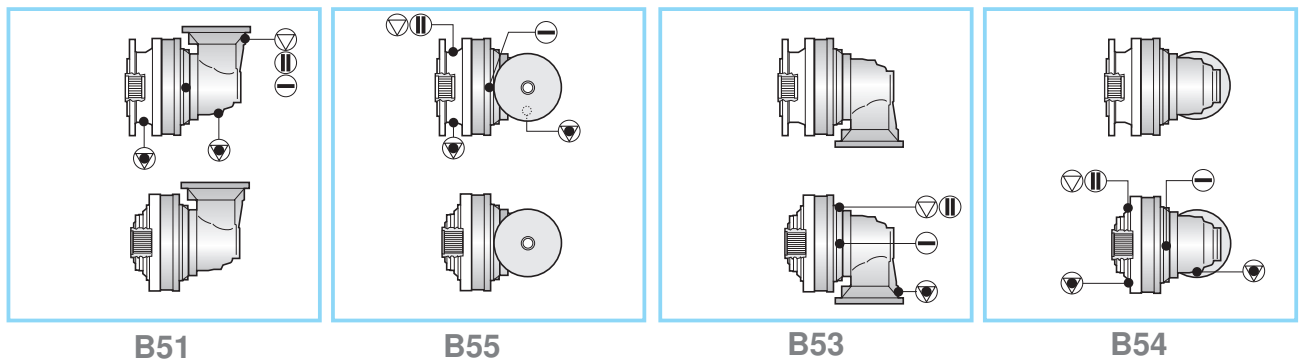

FS

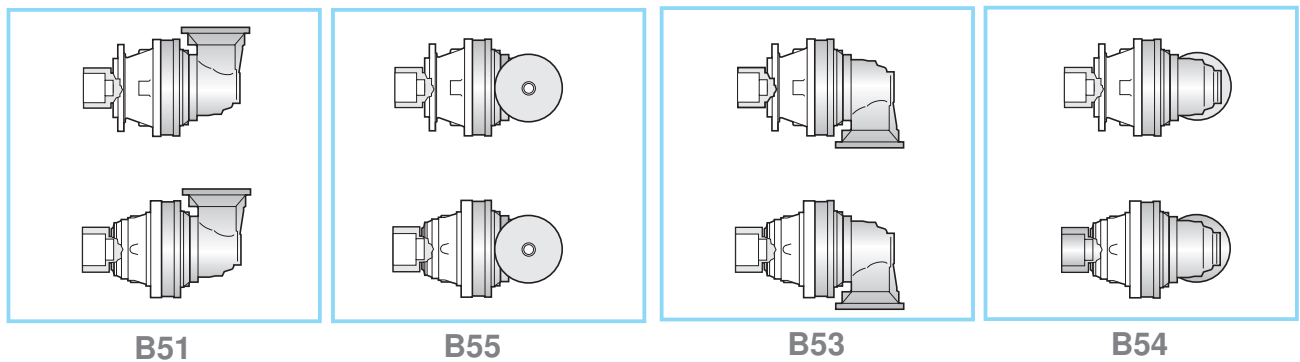

CPC

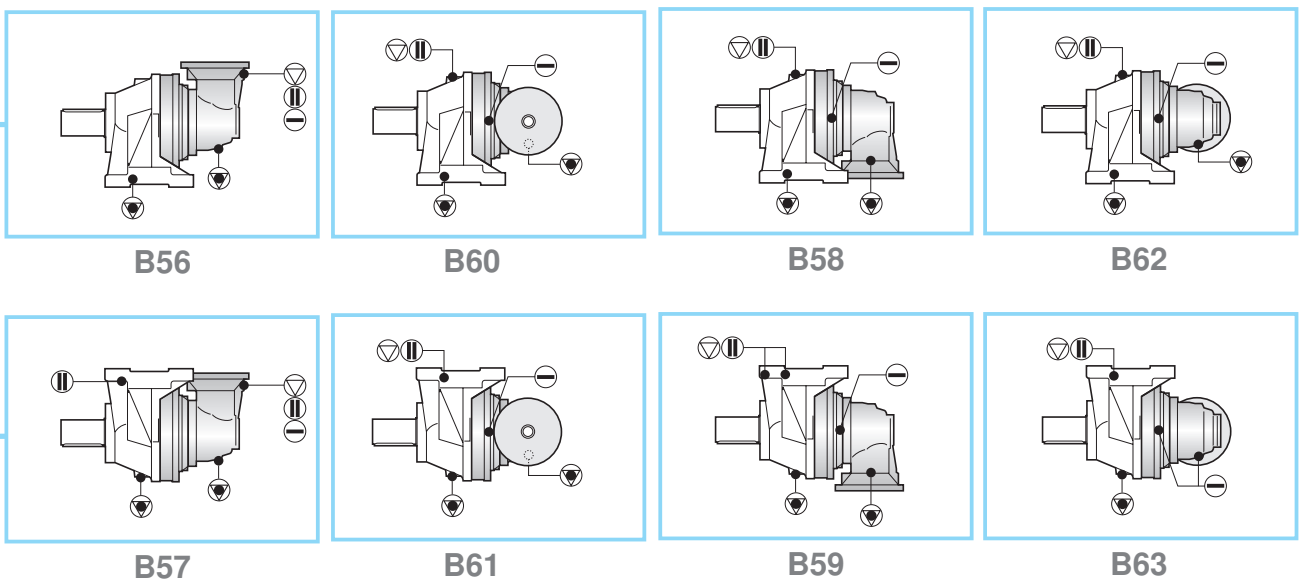

Posizioni di montaggio / Mounting positions / Einbauposition / Positions de montage / Posiciones de montaje / Posições de montagem

M-P

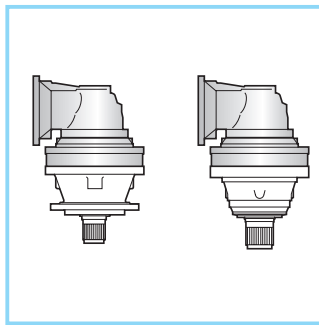

V15

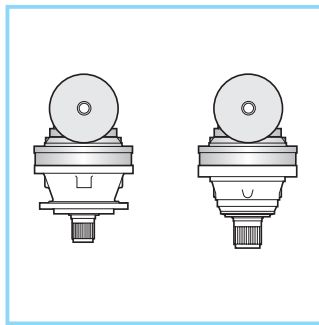

V16

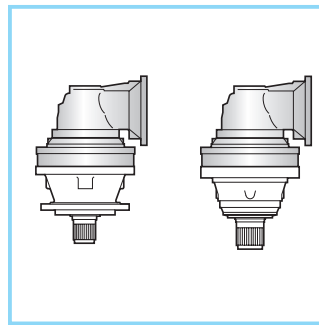

V17

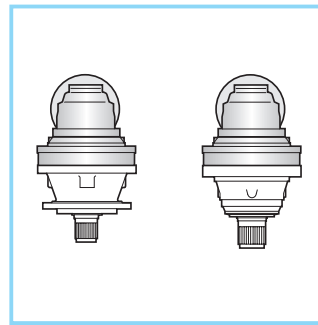

V18

F

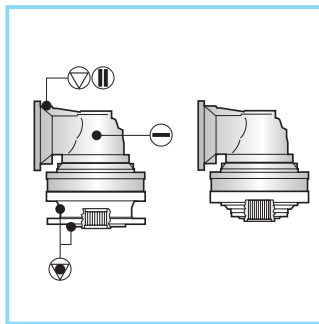

V15

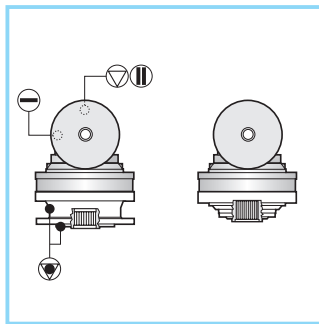

V16

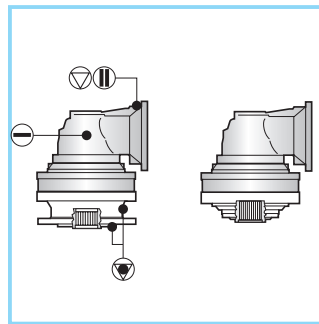

V17

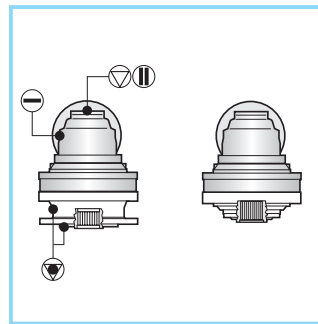

V18

FS

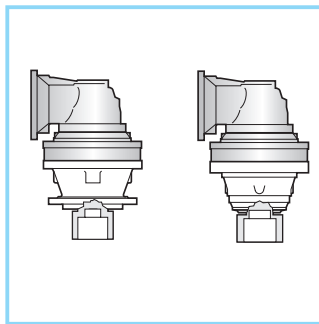

V15

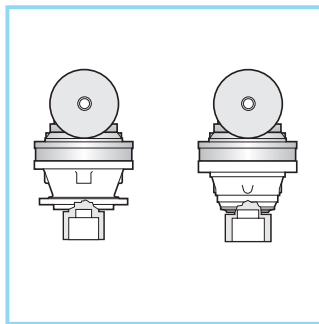

V16

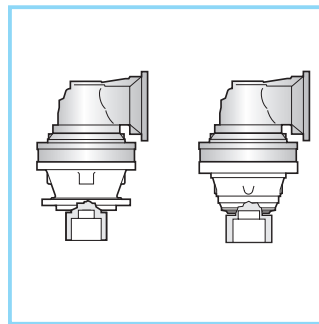

V17

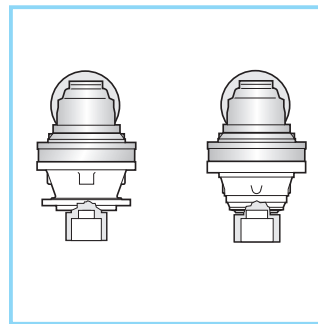

V18

CPC

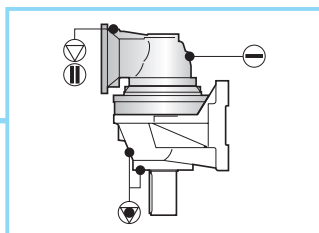

V53

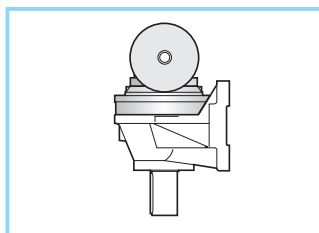

V52

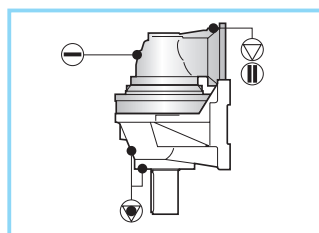

V54

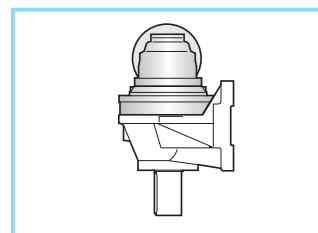

V55

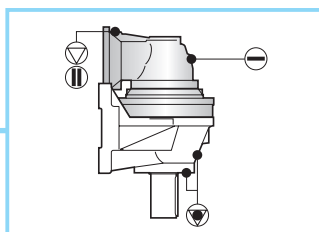

V49

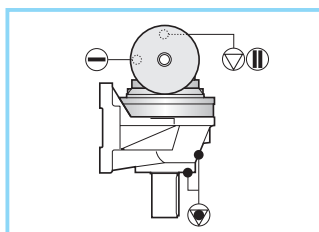

V48

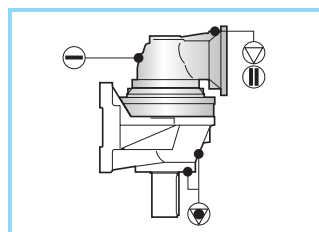

V50

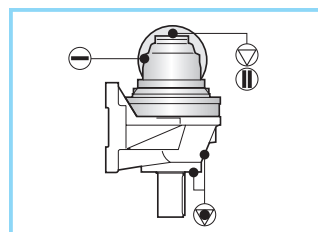

V51

Posizioni di montaggio / Mounting positions / Einbauposition / Positions de montage / Posiciones de montaje / Posições de montagem

INTR.

M-P

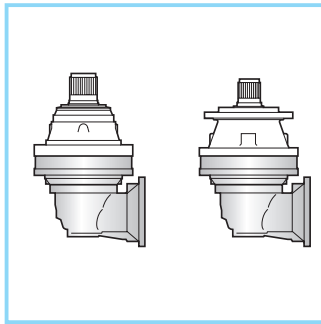

V35

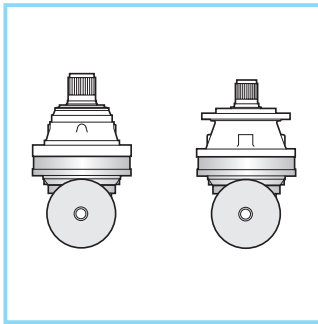

V36

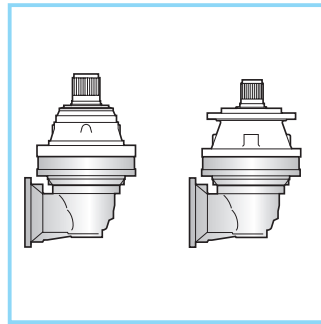

V37

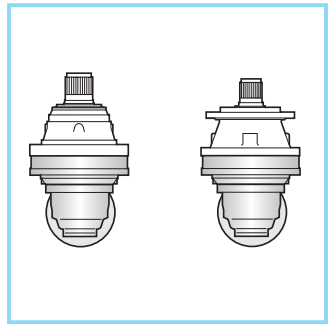

V38

F

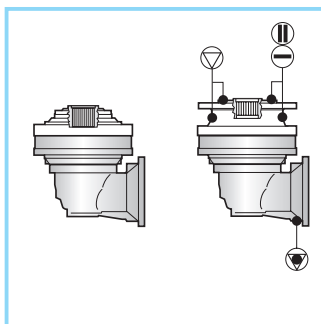

V35

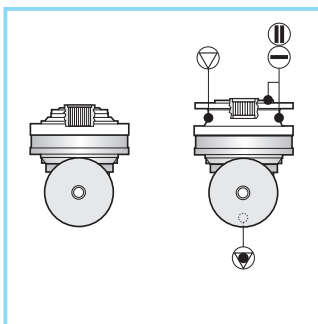

V36

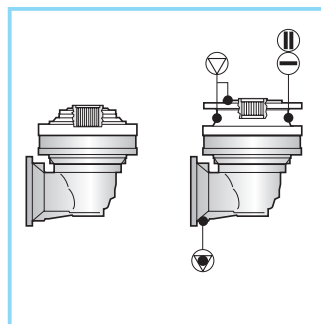

V37

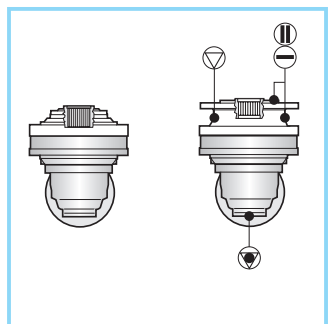

V38

FS

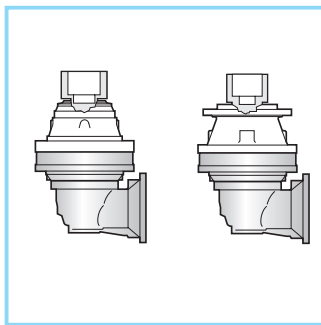

V35

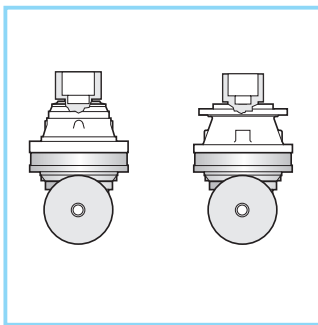

V36

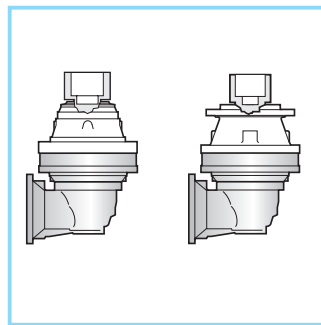

V37

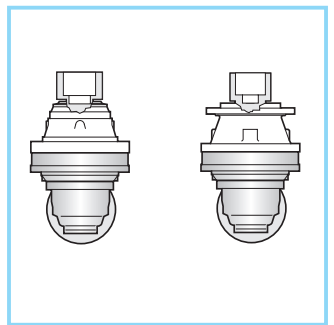

V38

CPC

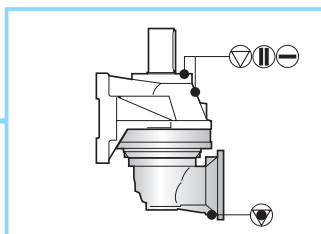

V42

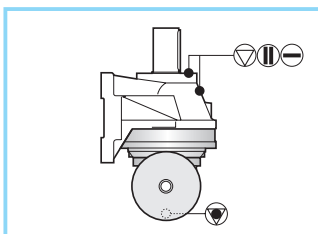

V40

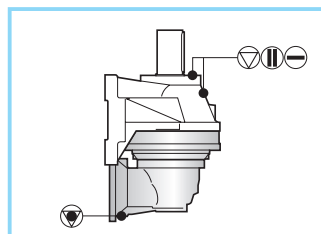

V41

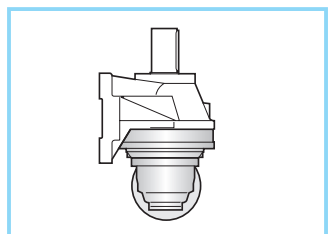

V43

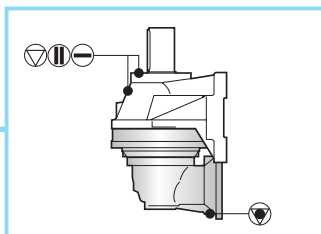

V46

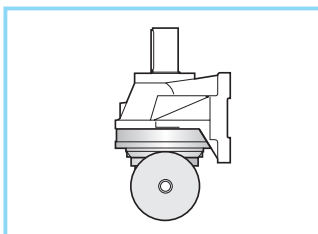

V44

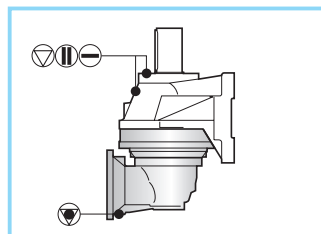

V45

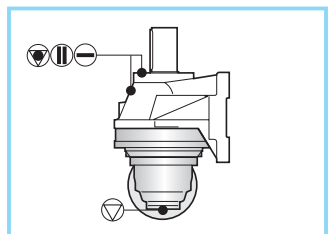

V47



**ACCESSORI USCITA
OUTPUT FITTINGS
ABTRIEBSBAUTEILE
ACCESSOIRES DE SORTIE
ACCESORIOS DE SALIDA
ACESSÓRIOS DE SAÍDA**

**VERSIONI USCITA
OUTPUT TYPES
ABTRIEBSWELLEN
TYPES DE SORTIE
VERSIONES DE SALIDA
VERSÕES DE SAÍDA**

**FORMA COSTRUTTIVA
TYPE OF REDUCTION UNIT
PLANETENSTUFEN
TYPE DU REDUCTEUR
FORMA CONSTRUCTIVA
FORMA CONSTRUCTIVA**

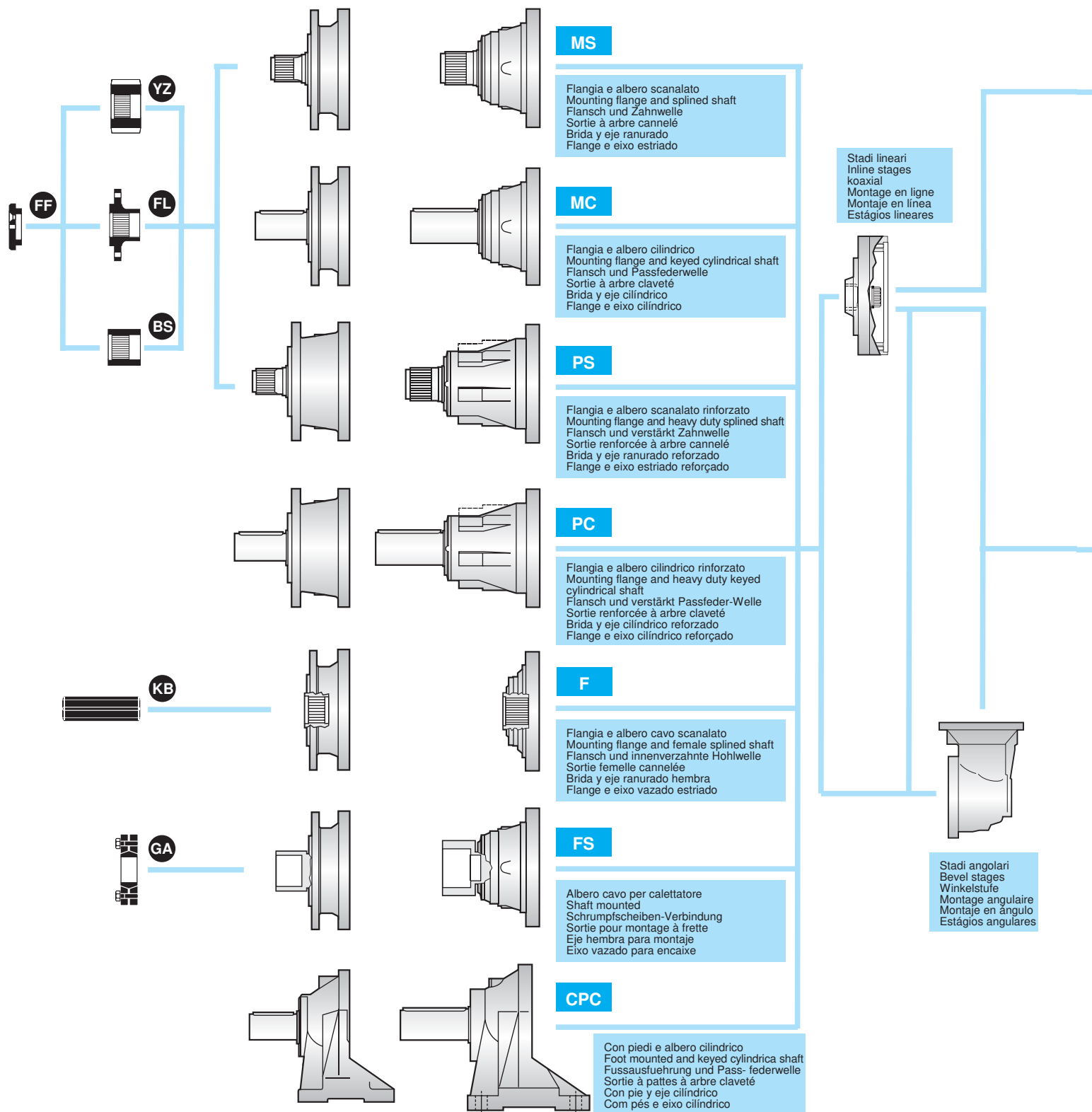

ACCESSORI ENTRATA / INPUT FITTINGS / ANTRIEBSBAUTEILE
 ACCESSOIRES D'ENTREE / ACCESORIOS DE ENTRADA / ACESSÓRIOS DE ENTRADA

INTR.

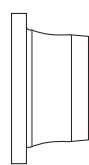

ED

Entrate dirette senza freno con attacco motore
 Direct input motor adaptor without brake
 Standardantrieb ohne Bremse mit Motorflansch
 Entrée standard sans frein pour adaptation moteur
 Entrada directa sin freno para acoplamiento motor
 Entrada direta sem freio com acoplamento ao motor

D-8

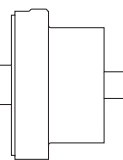

EDF

Entrate dirette con freno e attacco motore
 Direct input motor adaptor with brake
 Motorflansch mit integrierter Bremse
 Entrée directe avec frein pour adaptation moteur
 Entrada directa con freno para acoplamiento motor
 Entrada direta com freio e acoplamento ao motor

D-9

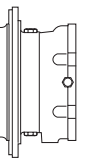

EF

Entrate dirette con freno e attacco motore
 Direct input motor adaptor with brake
 Motorflansch mit integrierter Bremse
 Entrée directe avec frein pour adaptation moteur
 Entrada directa con freno para acoplamiento motor
 Entrada direta com freio e acoplamento ao motor

D-9

RA

RB

Freno
 Brake
 Bremse
 Frein
 Frein
 Freio

D-2

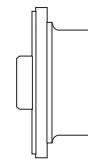

D-15

Predisposizione motore idraulico
 Hydraulic motor coupling
 Motorflansch Hydraulikmotor
 Adaptation moteur hydraulique
 Acoplamiento motor hidráulico
 Predisposição para motor hidráulico

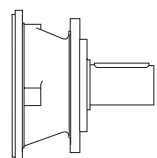

Albero entrata
 Input shaft
 Antriebswelle
 Arbre d'entrée
 Eje de entrada
 Eixo de entrada

D-4

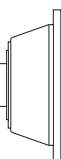

Predisposizione motore elettrico
 Electric motor coupling
 Motorflansch Elektromotor
 Adaptation moteur électrique
 Acoplamiento motor eléctrico
 Predisposição para motor elétrico

D-19

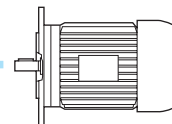

Motore elettrico
 Electric motor
 Elektromotor
 Moteur électrique
 Motor eléctrico
 Motor elétrico

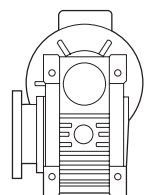

Predisposizione rid. vite senza fine
 Worm gearbox adaptor
 Motorflansch Schneckengetriebe
 Adaptation réducteur à vis sans fin
 Acoplamiento reductor de tornillo sin fin
 Predisposição para reductor de rosca sem fim

D-21

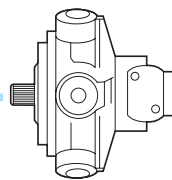

Motore a pistoni assiali
 Axial pistons motor
 Axialkolbenmotor
 Moteur à pistons axiaux
 Motor con pistones axiales
 Motor de pistões axiais

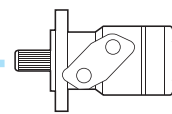

Motore orbitale
 Orbit motor
 Umlaufmotoren
 Moteur orbital
 Motor orbital
 Motor orbital

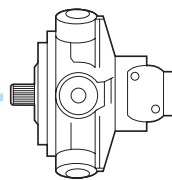

Motore a pistoni radiali
 Radial pistons motor
 Radialkolbenmotor
 Moteur à pistons radiales
 Motor con pistones radiales
 Motor de pistões radiais

RIDUTTORE / GEAR UNIT / GETRIEBE / REDUCTEUR / REDUTOR

P G **1 2 0 0 5** **M S** **1 2 0 8 . 8 9**

RAPPORTO / RATIO / VERHÄLTNIS
RAPPOR / RELACIÓN / RELAÇÃO

i
Vedi schede tecniche / See technical sheets
Siehe Datenblätter / Voir fiches techniques
Ver fichas técnicas / Ver fichas técnicas

VERSIONE E ALBERO DI USCITA / OUTPUT TYPE AND SHAFT
ABTRIEBSBAUTEILE UND ABTRIEBSWELLE / VERSION ET ARBRE DE SORTIE
VERSIÓN Y EJE DE SALIDA / VERSÃO E EIXO DE SAÍDA

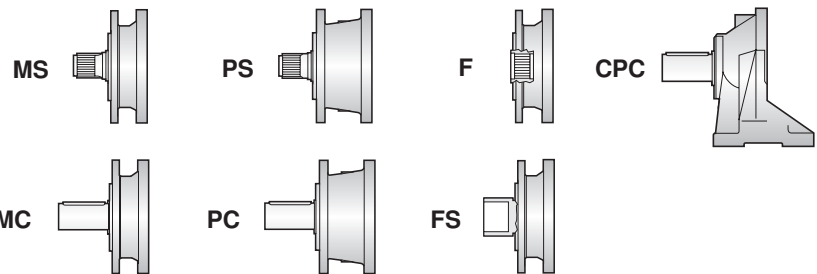

N° STADI / N° STAGES / N° STUFEN
Nº ETAGES / N° ETAPAS / Nº DE ESTÁGIOS

1, 2, 3, 4, 5

GRANDEZZA / SIZE / TAILLE / GRÖSSE / TAMAÑO / TAMANHO

100, 160, 250, 500, 700, 1000, 1600, 1800, 2500, 3000, 3500, 5000, 6500, 9000, 12000, 16000, 21000, 26000, 31000, 40000, 45000, 53000, 61000

FORMA COSTRUTTIVA / TYPE OF REDUCTION UNIT / TYPE DU REDUCTEUR
BAUFORM GETRIEBESTUFEN / FORMA CONSTRUCTIVA / FORMA CONSTRUTIVA

PG

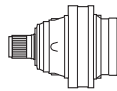

Riduttore con stadi lineari / Inline stages gear unit / koaxiale Ausfuehrung
Réducteur avec montage en ligne / Reductor con montaje en línea / Redutor com estágios lineares

PGA

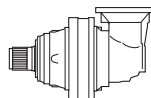

Riduttore con stadi angolari / Bevel stages gear unit / Ausfuehrung mit Winkelstufe
Réducteur avec montage angulaire / Reductor con montaje angular / Redutor com estágios angulares

Esempio di ordinazione:
Example of order:
Beispiel Bestellbeschreibung:
Exemple de commande:
Ejemplo orden de compra:
Exemplo de pedido:

PG 12005 MS 1208.89

ACCESSORI / FITTINGS / BAUTEILE / ACCESSOIRES / ACCESORIOS / ACESSÓRIOS

INTR.

B S **FF** **RA 25 4706 ...** **SAE A 4702 ...** **V 1**

USCITA / OUTPUT
 ABTRIEB / SORTIE
 SALIDA / SAÍDA

ENTRATA / INPUT
 ANTRIEB / ENTREE
 ENTRADA / ENTRADA

POSIZIONE DI MONTAGGIO
 MOUNTING POSITION
 EINBAUPOSITION
 POSITION DE MONTAGE
 POSICIÓN DE MONTAJE
 POSIÇÃO DE MONTAGEM

Vedi schede tecniche / See technical sheets
 Siehe Datenblätter / Voir fiches techniques
 Ver fichas técnicas / Ver fichas técnicas

Freni modulari / Brake
 Bremse / Frein
 Freno / Freios modulares

RA
RB

Albero entrata / Input shaft
 Antriebswelle / Arbre d'entrée
 Eje de entrada / Eixo de entrada

EL28, EL42, ...

Predisposizione motore elettrico / Electric motor coupling
 Motorflansch Elektromotor / Adaptation moteur électrique
 Acoplamiento motor eléctrico / Predisposição para motor elétrico

H71, H80, ...

Predisposizione motore idraulico / Hydraulic motor coupling
 Motorflansch Hydraulikmotor / Adaptation moteur hydraulique
 Acoplamiento motor hidráulico / Predisposição para motor hidráulico

SAE A, SAE B, ...

Entrata diretta con freno e attacco motore / Direct input motor adaptor with brake
 Motorflansch mit integrierter Bremse / Entrée directe avec frein pour adaptation moteur
 Entrada directa con freno para acoplamiento motor / Entrada direta com freio e acoplamento ao motor

EDF
EF

Entrata diretta senza freno e con attacco motore / Direct input motor adaptor without brake
 Standardantrieb / Entrée directe sans frein pour adaptation moteur
 Entrada directa sin freno para acoplamiento motor / Entrada direta sem freio com acoplamento ao motor

ED

Accessori di uscita / Output fittings / Abtriebsbauteile / Accessoires de sortie / Accesorios de salida / Acessórios de saída

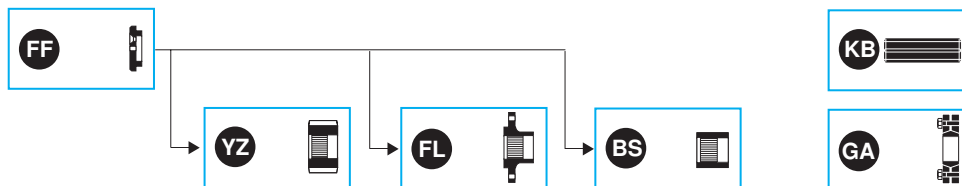

Esempio di ordinazione:
 Example of order:
 Beispiel Bestellbeschreibung:
 Exemple de commande:
 Ejemplo orden de compra:
 Exemplo de pedido:

BS FF RA 25 4706.002.500 SAE A 4702.012.012 V1

Cfs	[Nm]	Coppia frenante statica	Static braking torque	Bremsmoment, statisch	Couple de freinage statique	Momento de torsión estático de frenado	Torque de frenagem estática
Fa	[N]	Carico assiale	Axial load	Axiallast	Charge axiale	Carga axial	Carga axial
fh		Fattore di durata	Duration factor	Lebensdauerfaktor	Facteur de durée	Factor de duración	Fator de duração
fk		Fattore di adeguamento della capacità termica	Thermal power adjustment factor	Anpassungsfaktor Waerme- kapazitaet	Facteur d'adaptation de la capacité thermique	Factor de adaptación de la capacidad térmica	Fator de adaptação da capacidade térmica
Fr	[N]	Carico radiale	Radial load	Radiallast	Charge radiale	Carga radial	Carga radial
fs		Fattore di servizio	Service factor	Betriebsfaktor	Facteur de service	Factor de servicio	Fator de serviço
η		Rendimento	Efficiency	Wirkungsgrad	Rendement	Rendimiento	Rendimento
i		Rapporto di riduzione	Ratio	Übersetzung	Rapport	Relación de reducción	Relação de redução
K		Coefficiente di correzione del carico radiale	Radial load correction factor	Korrekturkoeffizient der Radiallast	Facteur de correction de charge radiale	Coeficiente de corrección de la carga radial	Coeficiente de correção da carga radial
Kg	[Kg]	Peso	Weight	Gewicht	Poids	Peso	Peso
Mc	[kNm]	Coppia continua	Continuous torque	Dauerbetriebsmoment	Couple continu	Momento de torsión continuo	Torque contínuo
Me	[kNm]	Coppia equivalente	Equivalent working torque	Equivalentes Betriebsmoment	Couple equivalent	Momento de torsión equivalente	Torque equivalente
M_{max}	[kNm]	Coppia massima	Maximum torque	Maximales Betriebsmoment	Couple maximal	Momento de torsión máximo	Torque máximo
Mp	[kNm]	Coppia di picco	Working peak torque	Spitzenmoment	Couple maximum de travail	Momento de torsión de pico	Torque de pico
n_{1 max}	[min ⁻¹]	Velocità massima in entrata	Maximum input speed	Max. zulaessige Antriebsdrehzahl	Vitesse maximale d'entrée	Velocidad máxima de entrada	Velocidade máxima na entrada
n₂	[min ⁻¹]	Velocità in uscita	Output speed	Abtriebsdrehzahl	Vitesse de sortie	Velocidad de salida	Velocidade na saída
nxh		Numero cicli	Cycles number	Anzahl der Zyklen	N ^o de cycles	Número de ciclos	Número de ciclos
Pa_{min}	[bar]	Pressione di apertura	Opening pressure	Bremsoeffnungsdruck	Pression d'ouverture	Presión de apertura	Pressão de abertura
P_{max}	[bar]	Pressione massima	Max pressure	Max. Betriebsdruck Bremse	Pression maxi	Presión máxima	Pressão máxima
Pt	[kW]	Potenza termica	Thermal power	Thermische Leistung	Puissance thermique	Potencia térmica	Potência térmica
		Informazioni	Information	Information	Information	Informaciones	Informações
		Quantità lubrificante	Oil quantity	Oelmenge	Quantité d'huile	Cantidad de lubricante	Quantidade de lubrificante

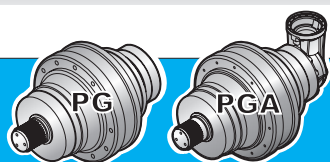

		i	Mc (n ₂ h 20.000) [kNm]	
B	(100 ÷ 9000)	(3.56 ÷ 8360.53)	(0.45 ÷ 99.00)	B-1
	100	PG 3.56 ÷ 3422.25 PGA 10.41 ÷ 1484.79	0.45 ÷ 1.10 0.70 ÷ 1.10	B-4
	160	PG 3.56 ÷ 3422.25	1.00 ÷ 1.70	B-12
		PGA 10.4 ÷ 1484.79	1.00 ÷ 1.70	
	250	PG 3.78 ÷ 2369.25	1.73 ÷ 3.52	B-20
		PGA 12.08 ÷ 1319.81	1.69 ÷ 3.34	
	500	PG 3.78 ÷ 1735.07	2.61 ÷ 5.11	B-28
		PGA 13.05 ÷ 1242.08	2.61 ÷ 5.11	
	700	PG 3.67 ÷ 2722.78	3.85 ÷ 7.02	B-36
		PGA 12.67 ÷ 1067.27	3.85 ÷ 7.02	
	1000	PG 3.56 ÷ 2229.71	4.41 ÷ 12.21	B-44
		PGA 12.28 ÷ 967.39	4.50 ÷ 12.21	
	1600	PG 3.56 ÷ 2229.71	9.13 ÷ 18.02	B-52
		PGA 10.92 ÷ 967.39	9.13 ÷ 18.02	
	1800	PG 13.04 ÷ 1561.86	12.01 ÷ 18.02	B-60
		PGA 45.04 ÷ 1184.17	12.39 ÷ 18.02	
	2500	PG 4.00 ÷ 2277.71	16.91 ÷ 30.76	B-68
		PGA 12.29 ÷ 1726.91	16.91 ÷ 24.55	
	3000	PG 14.22 ÷ 1425.06	23.51 ÷ 30.76	B-76
		PGA 43.68 ÷ 1385.48	23.51 ÷ 30.76	
3500	PG 4.00 ÷ 1289.65	21.65 ÷ 37.50	B-84	
	PGA 12.29 ÷ 1253.82	16.65 ÷ 37.11		
5000	PG 3.95 ÷ 1981.97	35.50 ÷ 60.80	B-92	
	PGA 12.15 ÷ 1326.27	20.64 ÷ 45.19		
6500	PG 3.83 ÷ 1005.54	52.67 ÷ 69.31	B-100	
	PGA 47.01 ÷ 911.35	49.57 ÷ 69.31		
9000	PG 4.04 ÷ 8360.53	65.49 ÷ 99.00	B-108	
	PGA 49.68 ÷ 1010.02	59.80 ÷ 79.00		
C	(12000 ÷ 61000)	(3.43 ÷ 8938.38)	(55.6 ÷ 858.1)	C-1

Le pagine che seguono riportano i dati tecnici prestazionali e dimensionali dei riduttori Serie PG-PGA. Per facilitare la ricerca della grandezza desiderata riportiamo la tabella sopraindicata con i dati indicativi e i riferimenti alle pagine.

The following pages show the technical information on performances and dimensions of the PG-PGA planetary the research and the selection of the required size you can refer to the above table, including some technical data and the corresponding page.

Die folgenden Seiten zeigen die technischen Daten bezüglich Leistung und Dimensionen der Produktserien PG-PGA. Um die Suche der gewünschten Groesse zu erleichtern, liefert die vorstehende Tabelle die Groessen in Verbindung zur entsprechenden Katalogseite.

Les page qui suivent se rapportent aux données techniques des prestations et dimensions des réducteurs série PG-PGA. Pour faciliter la sélection de la taille du réducteur envisagée, se référer au tableau ci-dessus pour se reporter à la page correspondante.

Las páginas siguientes contienen los datos técnicos de las prestaciones y dimensiones de la serie de reductores PG-PGA. Para facilitar la búsqueda de la dimensión deseada se puede consultar la siguiente tabla, con los datos indicativos y las páginas correspondientes.

As páginas seguintes mostram os dados técnicos de desempenho e as características dimensionais dos reductores da Série PG-PGA. Para facilitar a procura do tamanho desejado, reproduzimos a tabela a seguir com os dados indicativos e as referências às páginas.

DATI TECNICI / TECHNICAL DATA / TECHNISCHE DATEN
DONNEES TECHNIQUES / DATOS TÉCNICOS / DADOS TÉCNICOS

1 Tabelle dei dati tecnici relativi ai riduttori PG.
Technical data tables of PG series.
Tabelle mit den technischen Daten des entsprechenden PG - Getriebetyps.
Tableaux des données techniques sur les séries PG.
Tablas con los datos técnicos de los reductores PG.
Tabelas de dados técnicos dos reductores PG

2 Tabelle dei dati tecnici relativi ai riduttori PGA.
Technical data tables of PGA series.
Tabelle mit den technischen Daten des entsprechenden PGA - Getriebetyps.
Tableaux des données techniques sur les séries PGA.
Tablas con los datos técnicos de los reductores PGA.
Tabelas de dados técnicos dos reductores PGA.

3 Indicazione per il calcolo della coppia massima M_{max} .
Determination of the maximum torque M_{max} .
Anweisung zur Berechnung des maximalen Betriebsdrehmoments M_{max} .
Indications pour calculer le couple maxi M_{max} .
Determinación del momento máximo de torsión $M_{m\acute{a}x}$.
Indicação para o cálculo do torque máximo $M_{m\acute{a}x}$.

DIMENSIONI / DIMENSIONS / MASSE / DIMENSIONS / DIMENSIONES / DIMENSÕES

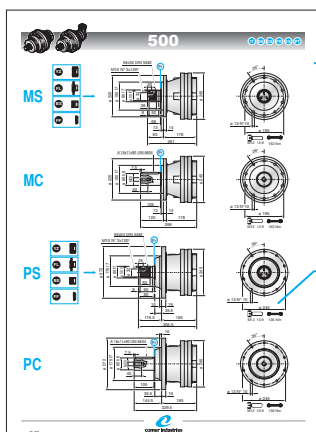

4 Queste pagine riportano le dimensioni delle uscite nelle varie configurazioni disponibili.
These pages show the outputs dimensions in their different possible configurations.
Auf diesen Seiten sind die Masse der diversen Abtriebstypen angegeben.
Ces pages montrent les dimensions des sorties dans leurs différentes configurations possibles.
Estas páginas contienen las dimensiones de las salidas en las distintas configuraciones disponibles.
Estas páginas fornecem as dimensões das saídas nas várias configurações disponíveis.

5 Questo simbolo fornisce le indicazioni sulle viti da utilizzare per il fissaggio del riduttore.
This symbol gives information about screws to use to mount the gearbox.
Diese Symbol gibt Hinweise zur Befestigung des Getriebes und die einzusetzenden Schrauben.
Ce symbole donne l'indication des vis à utiliser pour monter le réducteur.
Este símbolo suministra las indicaciones sobre los tornillos a utilizar para fijar el reductor.
Este símbolo fornece as indicações sobre os parafusos que devem ser usados para a fixação do redutor.

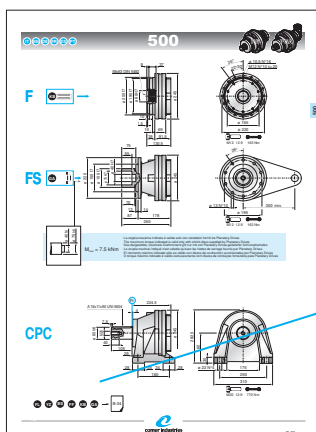

6 Simboli riferiti agli accessori applicabili in uscita al riduttore nelle configurazioni disponibili.
Symbols refer to suitable fittings on output in their possible configuration.
Diese Symbole zeigen die moeglichen Optionen im Bezug auf die verfuegbaren Abtriebsbauteile.
Symboles se référant aux accessoires applicables en sortie du réducteur et leurs configurations possibles.
Símbolos referidos a los accesorios aplicables en la salida del reductor para las configuraciones disponibles.
Símbolos referidos aos acessórios aplicáveis na saída do redutor nas configurações disponíveis.



Diametro della vite
Screw diameter
Durchmesser der Schrauben
Diamètre de vis
Diámetro del tornillo
Diâmetro do parafuso

Classe di resistenza
Screw quality
Schraubenfestigkeitsklasse
Classe de résistance
Clase de resistencia
Classe de resistência

Coppia di serraggio consigliata
Screw tightened torque
empfohlenes Anzugsdrehmoment
Couple de serrage conseillé
Par de apriete aconsejado
Torque de aperto aconselhado

ENTRATE / GEARBOX INPUTS / ANTRIEB / ENTREES / ENTRADAS / ENTRADAS

Queste pagine riportano le dimensioni di massimo ingombro del riduttore nelle varie configurazioni disponibili e i tipi di entrate, freni e motorizzazioni applicabili con l'indicazione delle pagine nelle quali reperire ulteriori dati. Il massimo ingombro del riduttore è ottenuto (come illustrato nei disegni seguenti) sommando alle quote A e B le dimensioni delle entrate utilizzate (L, P, Z) e le eventuali maggiorazioni dimensionali dove indicate.

These pages show overall dimensions of the gearboxes in their possible configurations plus the type of gearbox inputs, brakes and motor drives applicable with indication of the pages in which to find further information. Maximum gearbox overall dimension is obtained (see scheme below) adding the input dimensions used (L, P, Z) to a and b dimensions, plus possible oversize if indicated.

Diese Seiten geben die Aussenmasse der diversen Getriebetypen an. Dazu werden die moeglichen Optionen der verfuegbaren Antriebsformen, Bremsen gezeigt und auf die entsprechenden Katalogseiten hingewiesen. Das Gesamtausmass des Getriebes wird ermittelt (wie im nachstehenden Schema gezeigt), indem die Angaben aus dem vorgenannten Abtriebsausmass A und B, das Laengenmass des gewaehlten Antriebs (L, P, Z) und eventuellen Aufmasse (wenn angezeigt) addiert werden.

Ces pages montrent les dimensions extérieures des réducteurs dans leurs configurations possibles ainsi que les sortes d'entrées, freins et d'adaptations moteurs applicables avec les indications des pages dans lesquelles se trouvent de plus amples informations. La dimension extérieure maximum du réducteur est obtenue (voir schéma ci-dessous) en additionnant les dimensions des entrées utilisées (L, P, Z) aux dimensions A et B, plus la cote additionnelle si indiquée.

Estas páginas contienen las dimensiones exteriores máximas del reductor para las configuraciones disponibles y los tipos de entradas, frenos y motores conductores aplicables con la indicación de las páginas en las que se pueden obtener más informaciones. Las dimensiones máximas del reductor se obtienen (como se ilustra en los siguientes esquemas) sumando a las cotas A y B las dimensiones de las entradas utilizadas (L, P, Z) y los eventuales incrementos dimensionales donde esté indicado.

Estas páginas fornecem as dimensões máximas do reductor nas várias configurações disponíveis e os tipos de entradas, freios e acionamentos aplicáveis, com a indicação das páginas onde encontrar outros dados. Obtém-se as dimensões máximas do reductor (conforme ilustrado nos desenhos seguintes) somando as dimensões das entradas utilizadas (L, P, Z) mais as cotas adicionais, se indicadas, às medidas A e B.

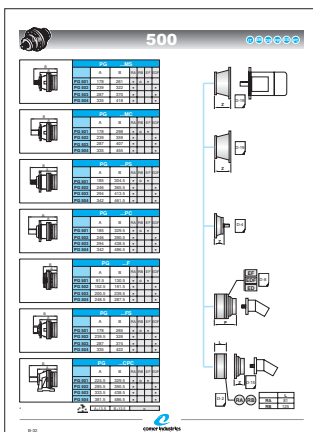

7

8

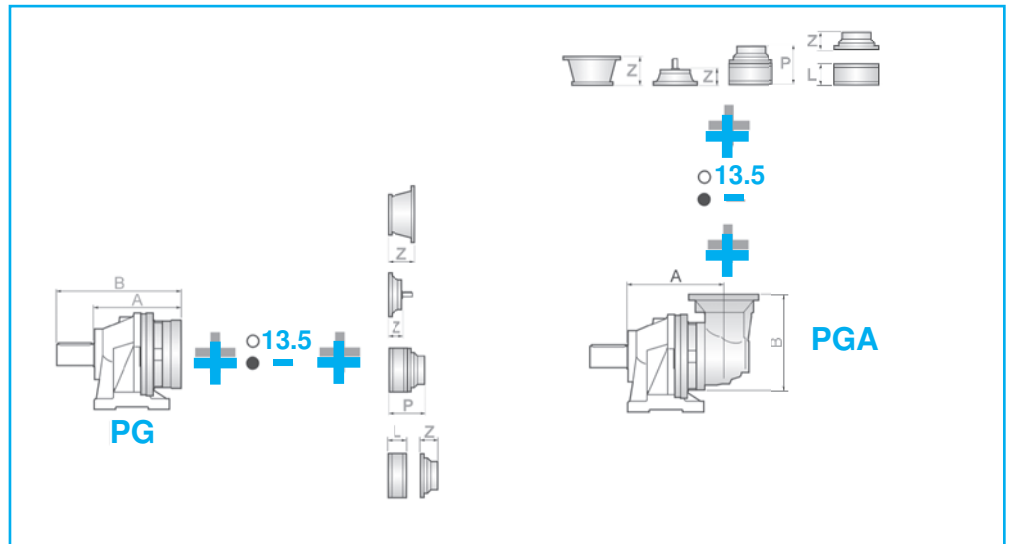

I simboli (•) riportati nelle tabelle indicano l'applicabilità dei freni (RA,RB) e delle entrate ED,EDF,EF. I simboli (o) indicano ugualmente l'applicabilità degli stessi componenti prevedendo una maggiorazione di lunghezza (come evidenziato nello schema sopra riportato).

The tables, show the suitability of the brakes (RA and RB) and of the inputs ED, EDF, EF. Symbols marked with (o) in the tables, also show the suitability of the same components increasing the length (as shown in the scheme above).

Das Symbol (•) in der Tabelle gibt an, welcher Bremsentyp (RA, RB) und welche Form der Antriebsvorrichtung ED, EDF oder EF verwendet werden kann. Das Symbol (o) hat dieselbe Funktion. Zusätzlich wird auf ein zu berücksichtigendes Aufmass hingewiesen (siehe oberes Schema).

Les symboles marqués d'un (•) dans les tableaux, montrent l'adaptation des freins (RA et RB) et des entrées ED, EDF, EF. Les symboles marqués d'un (o) dans les tableaux, montrent également l'adaptation des mêmes composants en augmentant la longueur (comme montré dans le schéma ci-dessous).

Los símbolos (•) contenidos en las tablas indican la factibilidad de aplicación de los frenos (RA, RB) y de las entradas ED, EDF, EF. Los símbolos (o) también indican la factibilidad de aplicación de los mismos componentes incrementando la longitud (como se evidencia en el esquema arriba indicado).

Os símbolos (•) presentes nas tabelas indicam a aplicabilidade dos freios (RA, RB) e das entradas ED, EDF, EF. Os símbolos (o) indicam igualmente a aplicabilidade dos mesmos componentes prevendo um aumento de comprimento (conforme mostrado no esquema acima).

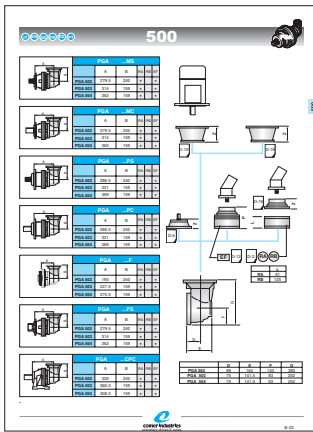

9

ACCESSORI USCITA
OUTPUT ACCESSORIES
ABTRIEBSBAUTEILE
ACCESSOIRES DE SORTIE
ACCESORIOS DE SALIDA
ACESSÓRIOS DE SAÍDA

Questa pagina riporta le dimensioni degli accessori disponibili.

This page shows dimensions of the available accessories.

Diese Seite gibt die Dimensionsmasse der verfügbaren Abtriebsbauteile an.

Cette page montre les dimensions des accessoires disponibles.

Esta página contiene las dimensiones de los accesorios disponibles.

Esta página fornece as dimensões dos acessórios disponíveis.

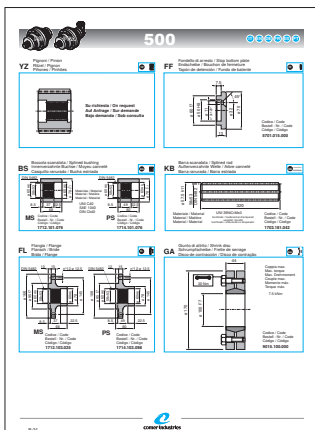

CARICHI RADIALI E ASSIALI
RADIAL AND AXIAL LOADS
RADIALLAST UND AXIALLAST
CHARGES RADIALES ET AXIALES
CARGAS RADIALES Y AXIALES
CARGAS RADIAIS E AXIAIS

Questa pagina riporta i diagrammi dai quali si ricavano i carichi radiali sugli alberi in uscita e le tabelle con i valori dei carichi assiali.

This page shows graphs to determine radial loads on output shafts and tables for axial load values.

Diese Seite zeigt die Diagramme, aus denen die Werte der Radiallast auf An- oder Abtriebswelle ermittelt werden koennen. Dazu sind hier die Tabellen mit den Werten der Axiallast ersichtlich.

Cette page montre les diagrammes des charges radiales sur les arbres de sortie et les tableaux avec les valeurs des charges axiales.

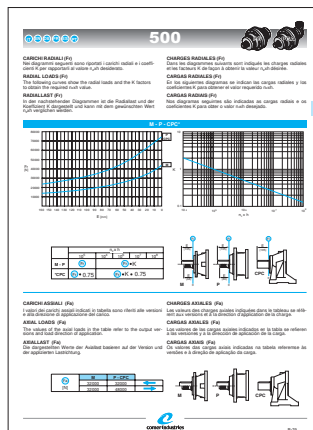



100

IT EN DE FR ES PT

	i	Mc [kNm]				n _{1max} [min ⁻¹]	Pt [kW]	Kg				
		n ₂ x h	n ₂ x h	n ₂ x h	n ₂ x h			M	P	CPC	F	FS
		10.000	20.000	50.000	100.000							
PG 101	3.56	1.24	1.10	0.94	0.83	2800	12	13	15	18	11	14
	4.29	1.24	1.10	0.94	0.83							
	5.60	0.90	0.80	0.68	0.60							
	6.75	0.79	0.70	0.60	0.53							
	8.67	0.51	0.45	0.38	0.34							
PG 102	12.64	1.24	1.10	0.94	0.83	2800	8	19	21	24	17	20
	15.24	1.24	1.10	0.94	0.83							
	19.91	1.24	1.10	0.94	0.83							
	24.00	1.24	1.10	0.94	0.83							
	28.93	1.24	1.10	0.94	0.83							
	31.36	0.90	0.80	0.68	0.60							
	37.14	1.24	1.10	0.94	0.83							
	48.53	0.90	0.80	0.68	0.60							
	58.50	0.79	0.70	0.60	0.53							
PG 103	54.18	1.24	1.10	0.94	0.83	2800	5	25	27	30	23	26
	65.31	1.24	1.10	0.94	0.83							
	70.80	1.24	1.10	0.94	0.83							
	78.72	1.24	1.10	0.94	0.83							
	85.33	1.24	1.10	0.94	0.83							
	102.86	1.24	1.10	0.94	0.83							
	111.50	1.24	1.10	0.94	0.83							
	134.40	1.24	1.10	0.94	0.83							
	162.00	1.24	1.10	0.94	0.83							
	172.56	1.24	1.10	0.94	0.83							
	208.00	1.24	1.10	0.94	0.83							
	211.68	0.90	0.80	0.68	0.60							
	255.15	0.90	0.80	0.68	0.60							
	271.79	0.90	0.80	0.68	0.60							
	307.55	0.79	0.70	0.60	0.53							
	321.90	1.24	1.10	0.94	0.83							
	394.88	0.79	0.70	0.60	0.53							
PG 104	337.36	1.24	1.10	0.94	0.83	2800	1.5	31	33	36	29	32
	365.71	1.24	1.10	0.94	0.83							
	396.45	1.24	1.10	0.94	0.83							
	440.82	1.24	1.10	0.94	0.83							
	477.87	1.24	1.10	0.94	0.83							
	531.34	1.24	1.10	0.94	0.83							
	576.00	1.24	1.10	0.94	0.83							
	624.41	1.24	1.10	0.94	0.83							
	694.29	1.24	1.10	0.94	0.83							
	752.64	1.24	1.10	0.94	0.83							
	836.86	1.24	1.10	0.94	0.83							
	907.20	1.24	1.10	0.94	0.83							
	966.35	1.24	1.10	0.94	0.83							
	1093.50	1.24	1.10	0.94	0.83							
	1144.55	1.24	1.10	0.94	0.83							
	1185.41	0.90	0.80	0.68	0.60							
	1318.06	1.24	1.10	0.94	0.83							
	1428.84	0.90	0.80	0.68	0.60							
	1692.32	1.24	1.10	0.94	0.83							
	3422.25	0.79	0.70	0.60	0.53							



	i	Mc [kNm]				n _{1max} [min ⁻¹]	Pt [kW]	Kg				
		n ₂ x h	n ₂ x h	n ₂ x h	n ₂ x h			M	P	CPC	F	FS
		10.000	20.000	50.000	100.000							
PGA 102	10.41	1.24	1.10	0.94	0.83	2800	8	28	30	33	26	29
	12.55	1.24	1.10	0.94	0.83							
	16.40	0.90	0.80	0.68	0.60							
	19.77	0.79	0.70	0.60	0.53							
PGA 103	37.02	1.24	1.10	0.94	0.83	2800	5	34	36	39	32	35
	44.63	1.24	1.10	0.94	0.83							
	53.79	1.24	1.10	0.94	0.83							
	58.31	1.24	1.10	0.94	0.83							
	70.29	1.24	1.10	0.94	0.83							
	84.72	1.24	1.10	0.94	0.83							
	90.24	1.24	1.10	0.94	0.83							
	108.78	1.24	1.10	0.94	0.83							
	133.43	0.79	0.70	0.60	0.53							
	142.13	0.90	0.80	0.68	0.60							
	171.32	0.79	0.70	0.60	0.53							
	PGA 104	131.64	1.24	1.10	0.94							
158.67		1.24	1.10	0.94	0.83							
191.25		1.24	1.10	0.94	0.83							
207.33		1.24	1.10	0.94	0.83							
230.53		1.24	1.10	0.94	0.83							
301.22		1.24	1.10	0.94	0.83							
326.54		1.24	1.10	0.94	0.83							
363.08		1.24	1.10	0.94	0.83							
393.60		1.24	1.10	0.94	0.83							
474.43		1.24	1.10	0.94	0.83							
514.30		0.90	0.80	0.68	0.60							
571.86		1.24	1.10	0.94	0.83							
609.14		1.24	1.10	0.94	0.83							
734.23		1.24	1.10	0.94	0.83							
782.11		1.24	1.10	0.94	0.83							
942.72		1.24	1.10	0.94	0.83							
1156.42		0.79	0.70	0.60	0.53							
1231.82		0.90	0.80	0.68	0.60							
1484.79	0.79	0.70	0.60	0.53								



(n₂ x h = 20.000)

$$M_{\max} = M_c \times 2$$

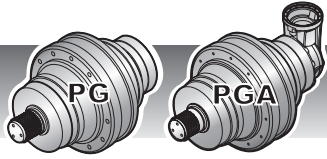

100

IT EN DE FR ES PT

MS

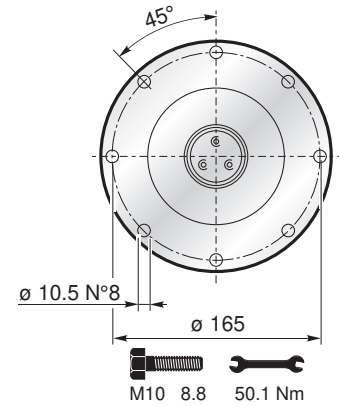
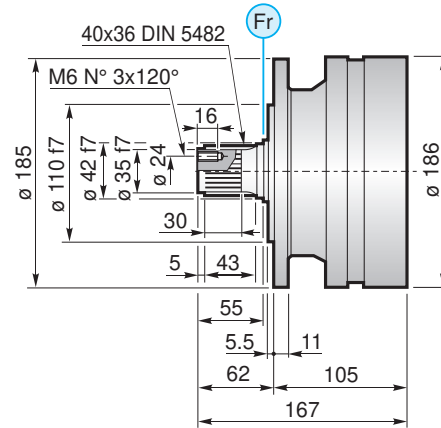
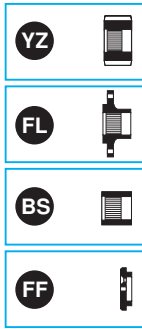

MC

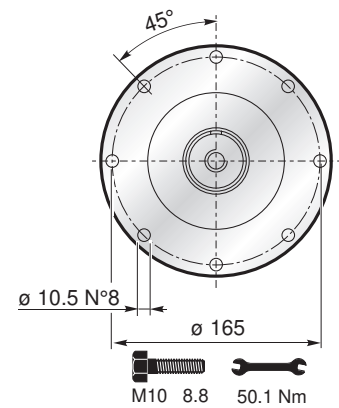
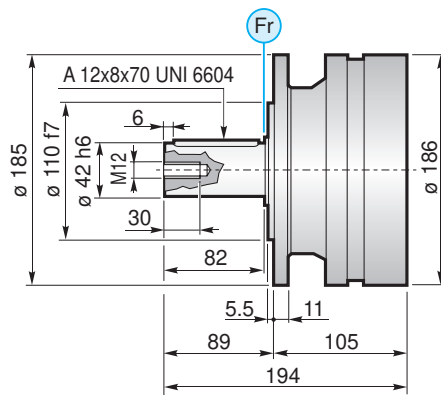

PS

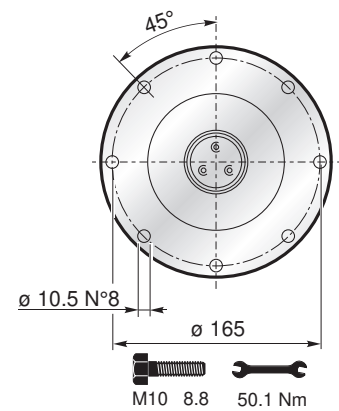
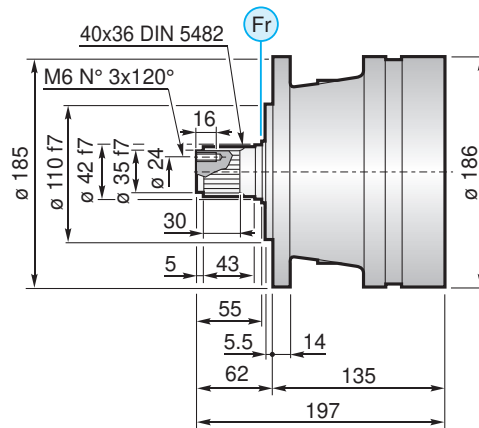
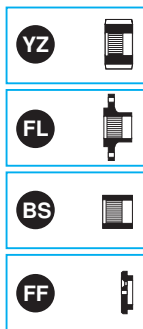

PC

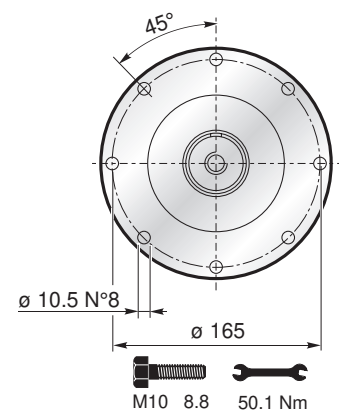
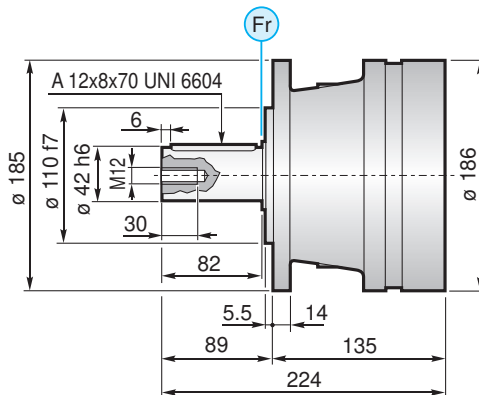

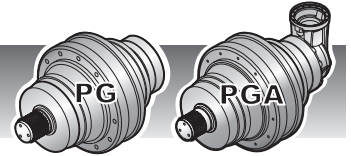

F

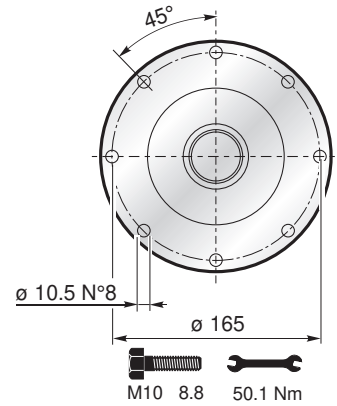
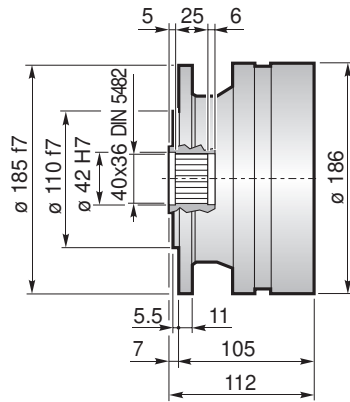
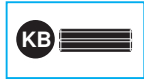

FS

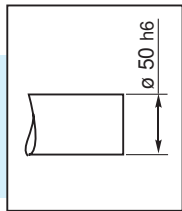
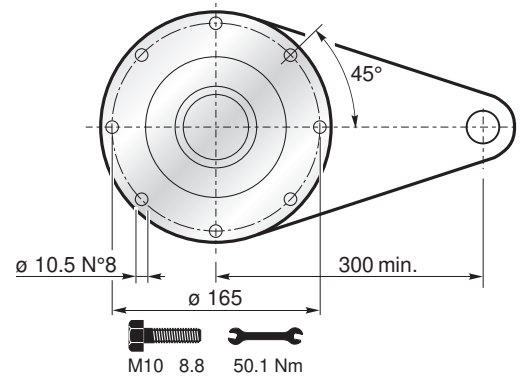
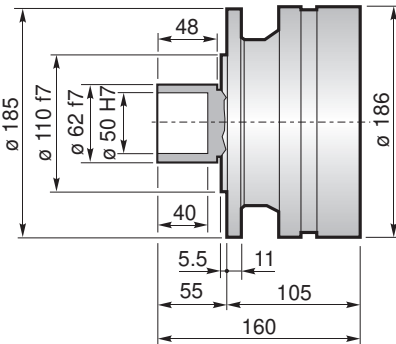

$M_{max} = 2.2 \text{ kNm}$

La coppia massima indicata è valida solo con calettatori forniti da Planetary Drives
 The maximum torque indicated is valid only with shrink discs supplied by Planetary Drives
 Das dargestellte, maximale Drehmoment gilt nur mit von Planetary Drives gelieferter Schrumpfscheibe
 Le couple maximal indiqué n'est valable qu'avec les frettes de serrage fournis par Planetary Drives
 El momento máximo indicado sólo es válido con discos de contracción suministrados por Planetary Drives
 O torque máximo indicado é válido exclusivamente com discos de contração fornecidos pela Planetary Drives

CPC

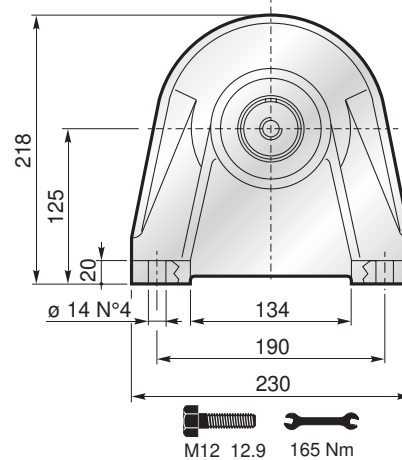
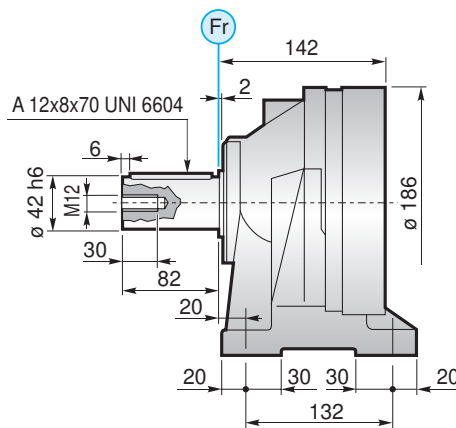

FL YZ BS FF KB GA → B-10

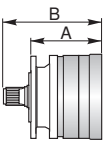

	PG ...MS					
	A	B	RA	RB	EF	EDF
PG 101	105	167	•			•
PG 102	153	215	•			•
PG 103	201	263	•			•
PG 104	249	311	•			•

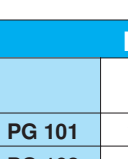
	PG ...MC					
	A	B	RA	RB	EF	EDF
PG 101	105	194	•			•
PG 102	153	242	•			•
PG 103	201	290	•			•
PG 104	249	338	•			•

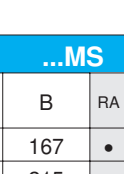
	PG ...PS					
	A	B	RA	RB	EF	EDF
PG 101	135	197	•			•
PG 102	183	245	•			•
PG 103	231	293	•			•
PG 104	271	341	•			•

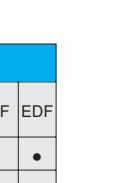
	PG ...PC					
	A	B	RA	RB	EF	EDF
PG 101	135	224	•			•
PG 102	183	272	•			•
PG 103	231	320	•			•
PG 104	279	368	•			•

	PG ...F					
	A	B	RA	RB	EF	EDF
PG 101	105	112	•			•
PG 102	153	160	•			•
PG 103	201	208	•			•
PG 104	249	256	•			•

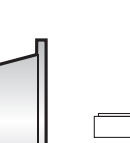
	PG ...FS					
	A	B	RA	RB	EF	EDF
PG 101	105	160	•			•
PG 102	153	208	•			•
PG 103	201	256	•			•
PG 104	249	304	•			•

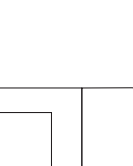
	PG ...CPC					
	A	B	RA	RB	EF	EDF
PG 101	142	224	•			•
PG 102	190	272	•			•
PG 103	238	320	•			•
PG 104	287	368	•			•

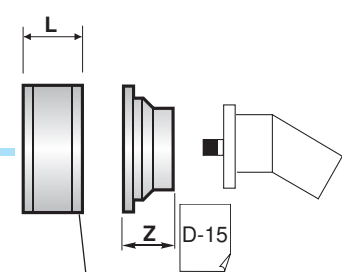
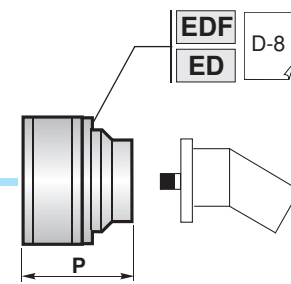
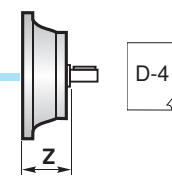
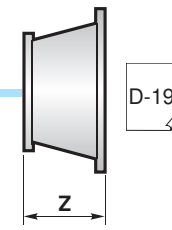
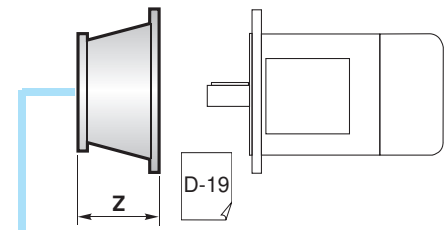

D-2	RA	L
	RA	81



	PGA ...MS					
		A	B	RA	RB	EF
PGA 102	180	159	•		•	
PGA 103	228	159	•		•	
PGA 104	276	159	•		•	

	PGA ...MC					
		A	B	RA	RB	EF
PGA 102	180	159	•		•	
PGA 103	228	159	•		•	
PGA 104	276	159	•		•	

	PGA ...PS					
		A	B	RA	RB	EF
PGA 102	210	159	•		•	
PGA 103	258	159	•		•	
PGA 104	306	159	•		•	

	PGA ...PC					
		A	B	RA	RB	EF
PGA 102	210	159	•		•	
PGA 103	258	159	•		•	
PGA 104	306	159	•		•	

	PGA ...F					
		A	B	RA	RB	EF
PGA 102	180	159	•		•	
PGA 103	228	159	•		•	
PGA 104	276	159	•		•	

	PGA ...FS					
		A	B	RA	RB	EF
PGA 102	180	159	•		•	
PGA 103	228	159	•		•	
PGA 104	276	159	•		•	

	PGA ...CPC					
		A	B	RA	RB	EF
PGA 102	217	159	•		•	
PGA 103	265	159	•		•	
PGA 104	313	159	•		•	

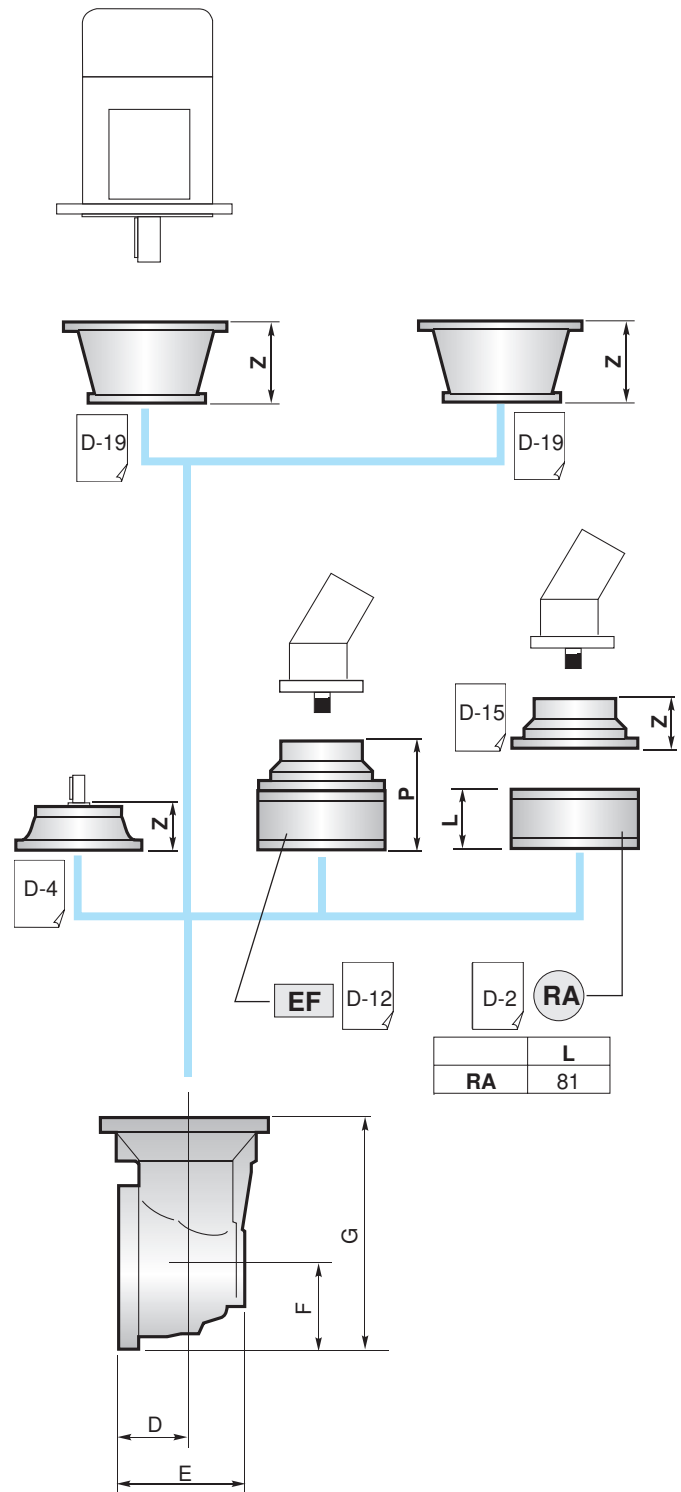

	D	E	F	G
PGA 102	75	141.5	93	252
PGA 103	75	141.5	93	252
PGA 104	75	141.5	93	252

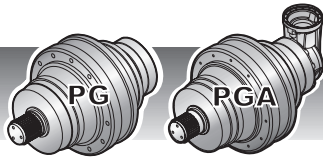

100

IT EN DE FR ES PT

YZ

Pignoni / Pinion
Ritzel / Pignon
Piñones / Pinhões

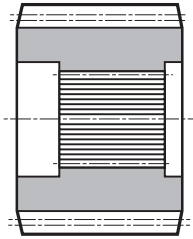

Su richiesta / On request
Auf Anfrage / Sur demande
Bajo demanda / Sob consulta

FF

Fondello di arresto / Stop bottom plate
Endscheibe / Bouchon de fermeture
Tapón de detención / Fundo de batente

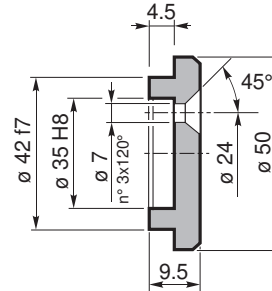

Codice / Code
Bestell - Nr. / Code
Código / Código
5701.034.000

BS

Boccola scanalata / Splined bushing
Innenverzahnte Buchse / Moyeu cannelé
Casquillo ranurado / Bucha estriada

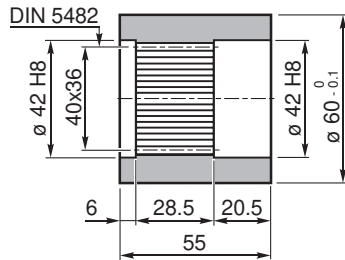

Materiale / Material
Material / Matière
Material / Material
UNI C40
SAE 1040
DIN Ck40

Codice / Code
Bestell - Nr. / Code
Código / Código
1710.100.076

KB

Barra scanalata / Splined rod
Außenverzahnte Welle / Arbre cannelé
Barra ranurada / Barra estriada

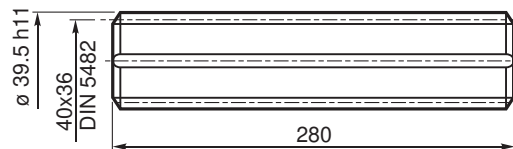

Materiale / Material
Material / Matière
Material / Material

UNI 39NiCrMo3
bonificato / hardened and tempered
vergütet / bonifié
bonificado / endurecido e temperado

Codice / Code
Bestell - Nr. / Code
Código / Código
1703.179.042

FL

Flangia / Flange
Flansch / Bride
Brida / Flange

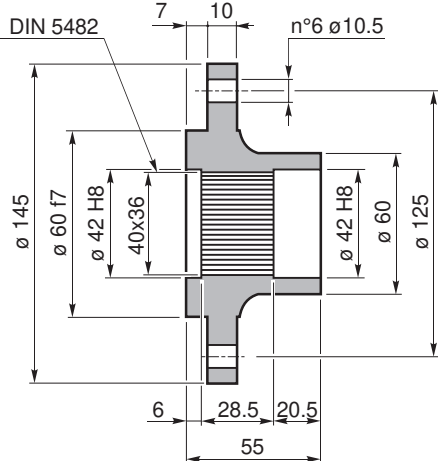

Codice / Code
Bestell - Nr. / Code
Código / Código
1710.102.025

GA

Giunto di attrito / Shrink disc
Schrumpfscheibe / Frette de serrage
Disco de contracción / Disco de contração

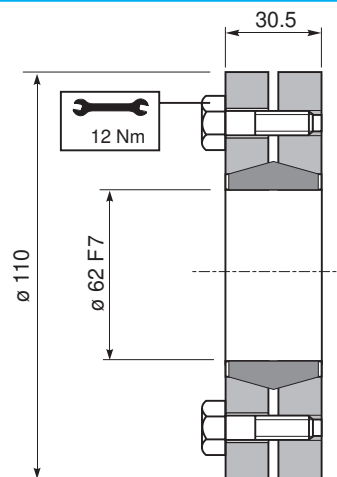

Coppia max.
Max. torque
Max. Drehmoment
Couple max.
Momento máx.
Torque máx.
2.2 kNm

Codice / Code
Bestell - Nr. / Code
Código / Código
9015.062.000

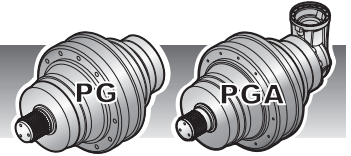

CARICHI RADIALI (Fr)

Nei diagrammi seguenti sono riportati i carichi radiali e i coefficienti K per rapportarli al valore $n_2 \times h$ desiderato.

RADIAL LOADS (Fr)

The following curves show the radial loads and the K factors to obtain the required $n_2 \times h$ value.

RADIALLAST (Fr)

In den nachstehenden Diagrammen ist die Radiallast und der Koeffizient K dargestellt und kann mit dem gewünschten Wert $n_2 \times h$ verglichen werden.

CHARGES RADIALES (Fr)

Dans les diagrammes suivants sont indiqués les charges radiales et les facteurs K de façon à obtenir la valeur $n_2 \times h$ désirée.

CARGAS RADIALES (Fr)

En los siguientes diagramas se indican las cargas radiales y los coeficientes K para obtener el valor requerido $n_2 \times h$.

CARGAS RADIAIS (Fr)

Nos diagramas seguintes são indicadas as cargas radiais e os coeficientes K para obter o valor $n_2 \times h$ desejado.

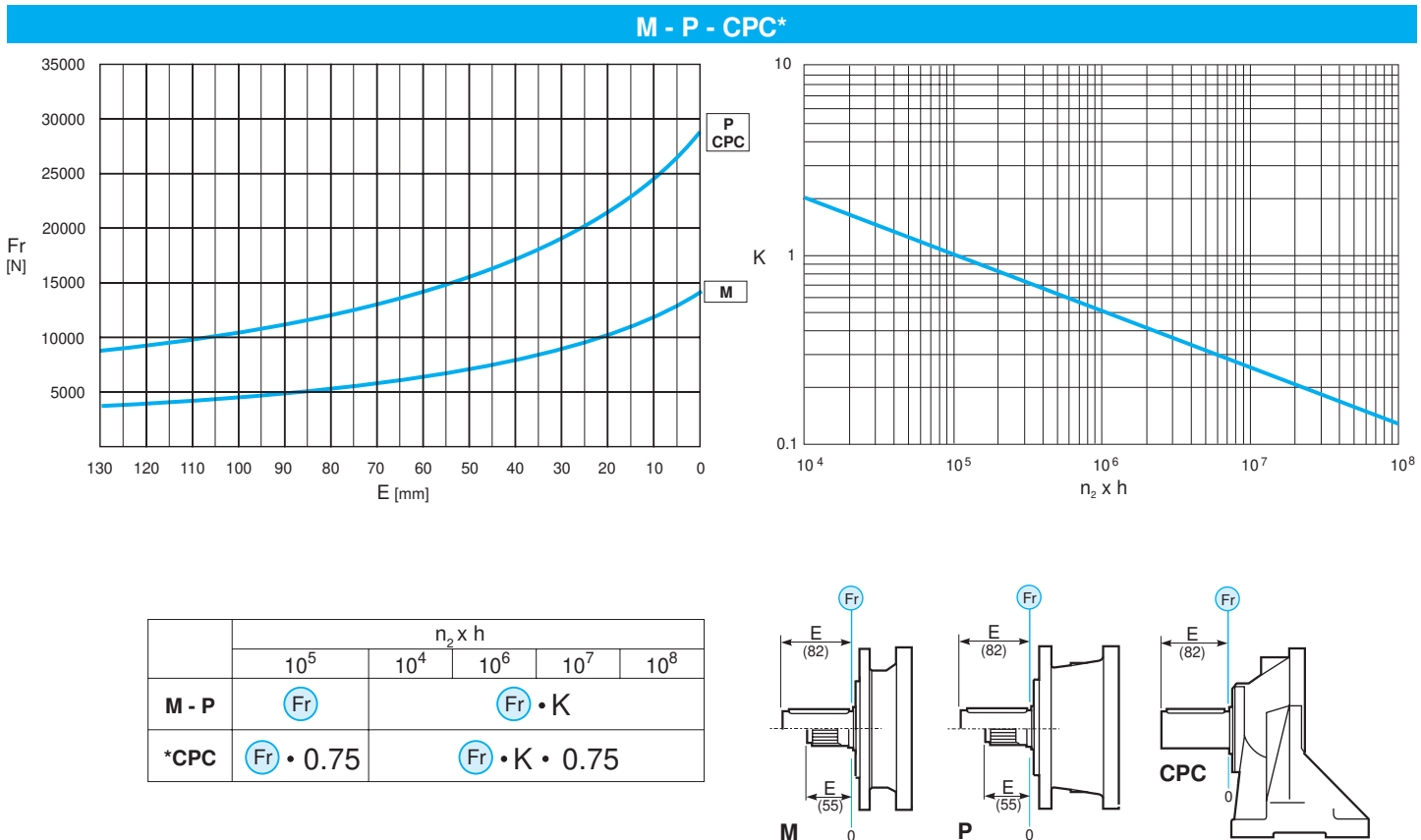

CARICHI ASSIALI (Fa)

I valori dei carichi assiali indicati in tabella sono riferiti alle versioni e alla direzione di applicazione del carico.

AXIAL LOADS (Fa)

The values of the axial loads in the table refer to the output versions and load direction of application.

AXIALLAST (Fa)

Die dargestellten Werte der Axiallast basieren auf der Version und der applizierten Lastrichtung.

CHARGES AXIALES (Fa)

Les valeurs des charges axiales indiquées dans le tableau se réfèrent aux versions et à la direction d'application de la charge.

CARGAS AXIALES (Fa)

Los valores de las cargas axiales indicados en la tabla se refieren a las versiones y a la dirección de aplicación de la carga.

CARGAS AXIAIS (Fa)

Os valores das cargas axiais indicadas na tabela referem-se às versões e à direção de aplicação da carga.

Fa [N]	M	P - CPC	← →
	16000	18000	
	16000	18000	

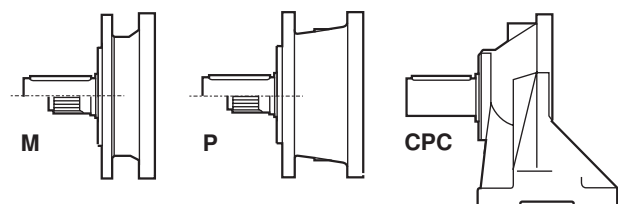



160

IT EN DE FR ES PT

	i	Mc [kNm]				n _{1max} [min ⁻¹]	Pt [kW]	Kg				
		n ₂ x h	n ₂ x h	n ₂ x h	n ₂ x h			M	P	CPC	F	FS
		10.000	20.000	50.000	100.000							
PG 161	3.56	1.92	1.70	1.45	1.28	2800	12	15	17	20	13	16
	4.29	1.92	1.70	1.45	1.28							
	5.60	1.37	1.21	1.03	0.91							
	6.75	1.13	1.00	0.85	0.75							
PG 162	12.64	1.92	1.70	1.45	1.28	2800	8	21	23	26	19	22
	15.24	1.92	1.70	1.45	1.28							
	19.91	1.92	1.70	1.45	1.28							
	24.00	1.92	1.70	1.45	1.28							
	28.93	1.92	1.70	1.45	1.28							
	31.36	1.37	1.21	1.03	0.91							
	37.80	1.37	1.21	1.03	0.91							
	45.56	1.13	1.00	0.85	0.75							
	58.50	1.13	1.00	0.85	0.75							
PG 163	54.18	1.92	1.70	1.45	1.28	2800	5	27	29	32	25	28
	65.31	1.92	1.70	1.45	1.28							
	70.80	1.92	1.70	1.45	1.28							
	78.72	1.92	1.70	1.45	1.28							
	85.33	1.92	1.70	1.45	1.28							
	102.86	1.92	1.70	1.45	1.28							
	111.50	1.92	1.70	1.45	1.28							
	134.40	1.92	1.70	1.45	1.28							
	162.00	1.92	1.70	1.45	1.28							
	172.56	1.92	1.70	1.45	1.28							
	208.00	1.92	1.70	1.45	1.28							
	211.68	1.37	1.21	1.03	0.91							
	250.71	1.92	1.70	1.45	1.28							
	271.79	1.37	1.21	1.03	0.91							
	307.55	1.13	1.00	0.85	0.75							
	327.60	1.37	1.21	1.03	0.91							
394.88	1.13	1.00	0.85	0.75								
PG 164	337.36	1.92	1.70	1.45	1.28	2800	1.5	33	35	38	31	34
	365.71	1.92	1.70	1.45	1.28							
	396.45	1.92	1.70	1.45	1.28							
	440.82	1.92	1.70	1.45	1.28							
	477.87	1.92	1.70	1.45	1.28							
	531.34	1.92	1.70	1.45	1.28							
	576.00	1.92	1.70	1.45	1.28							
	624.41	1.92	1.70	1.45	1.28							
	694.29	1.92	1.70	1.45	1.28							
	752.64	1.92	1.70	1.45	1.28							
	836.86	1.92	1.70	1.45	1.28							
	907.20	1.92	1.70	1.45	1.28							
	966.35	1.92	1.70	1.45	1.28							
	1093.50	1.92	1.70	1.45	1.28							
	1144.55	1.65	1.45	1.23	1.10							
	1185.41	1.37	1.21	1.03	0.91							
	1318.06	1.92	1.70	1.45	1.28							
	1404.00	1.92	1.70	1.45	1.28							
	1692.32	1.92	1.70	1.45	1.28							
	3422.25	1.13	1.00	0.85	0.75							



	i	Mc [kNm]				n _{1max} [min ⁻¹]	Pt [kW]	Kg				
		n ₂ x h	n ₂ x h	n ₂ x h	n ₂ x h			M	P	CPC	F	FS
		10.000	20.000	50.000	100.000							
PGA 162	10.41	1.92	1.70	1.45	1.28	2800	8	30	32	35	28	31
	12.55	1.92	1.70	1.45	1.28							
	16.40	1.37	1.21	1.03	0.91							
	19.77	1.13	1.00	0.85	0.75							
PGA 163	37.02	1.92	1.70	1.45	1.28	2800	5	36	38	41	34	37
	44.63	1.92	1.70	1.45	1.28							
	53.79	1.92	1.70	1.45	1.28							
	58.31	1.92	1.70	1.45	1.28							
	70.29	1.92	1.70	1.45	1.28							
	84.72	1.92	1.70	1.45	1.28							
	91.84	1.37	1.21	1.03	0.91							
	110.70	1.37	1.21	1.03	0.91							
	133.43	1.13	1.00	0.85	0.75							
	142.13	1.37	1.21	1.03	0.91							
	171.32	1.13	1.00	0.85	0.75							
PGA 164	131.64	1.92	1.70	1.45	1.28	2800	1.5	42	44	47	40	43
	158.67	1.92	1.70	1.45	1.28							
	191.25	1.92	1.70	1.45	1.28							
	207.33	1.92	1.70	1.45	1.28							
	230.53	1.92	1.70	1.45	1.28							
	301.22	1.92	1.70	1.45	1.28							
	326.54	1.92	1.70	1.45	1.28							
	363.08	1.92	1.70	1.45	1.28							
	393.60	1.92	1.70	1.45	1.28							
	474.43	1.92	1.70	1.45	1.28							
	514.30	1.37	1.21	1.03	0.91							
	571.86	1.92	1.70	1.45	1.28							
	609.14	1.92	1.70	1.45	1.28							
	734.23	1.92	1.70	1.45	1.28							
	795.95	1.37	1.21	1.03	0.91							
	942.72	1.65	1.45	1.23	1.10							
	1156.42	1.13	1.00	0.85	0.75							
1231.82	1.37	1.21	1.03	0.91								
1484.79	1.13	1.00	0.85	0.75								



(n₂ x h = 20.000)
 $M_{max} = M_c \times 2$

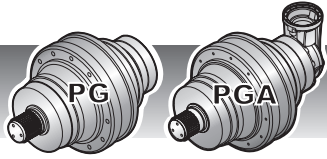

160

IT EN DE FR ES PT

MS

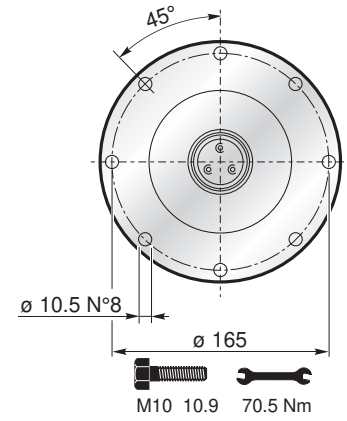
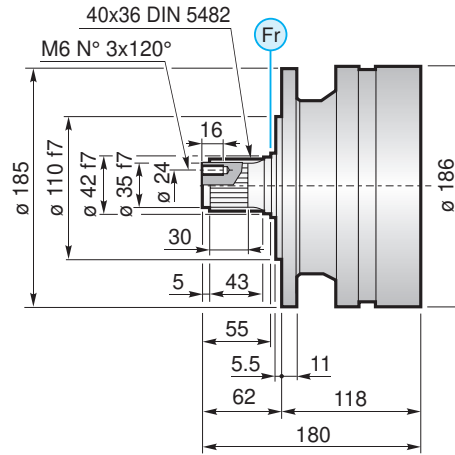
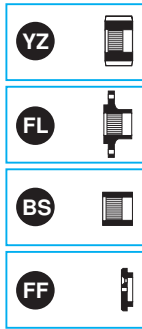

MC

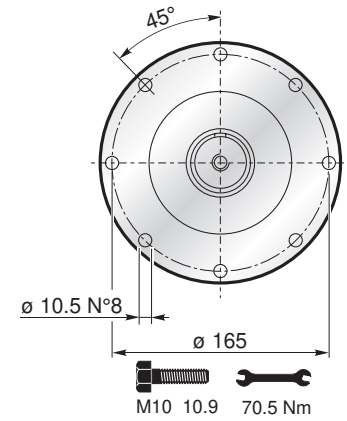
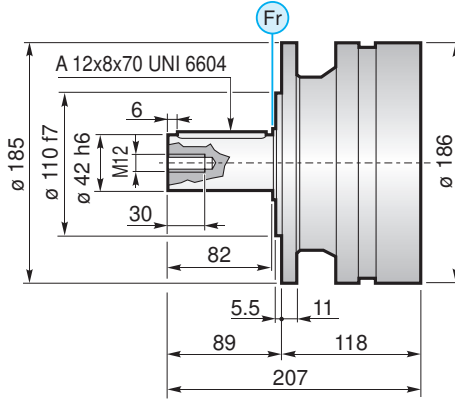

PS

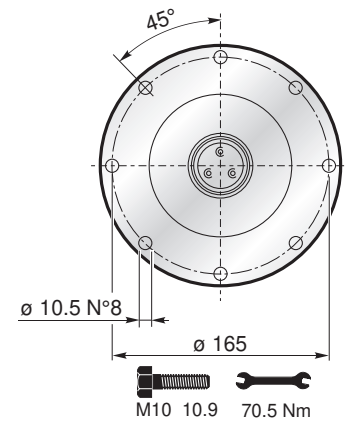
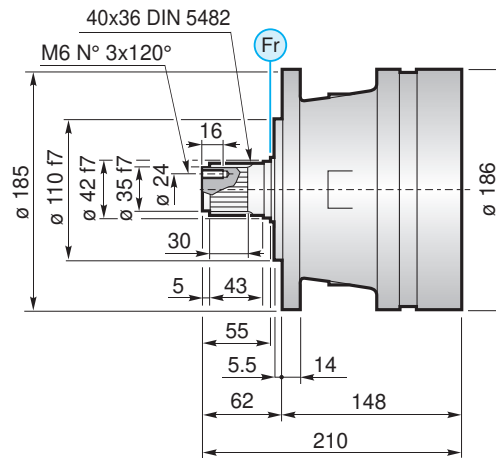
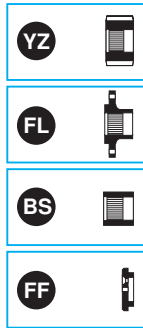

PC

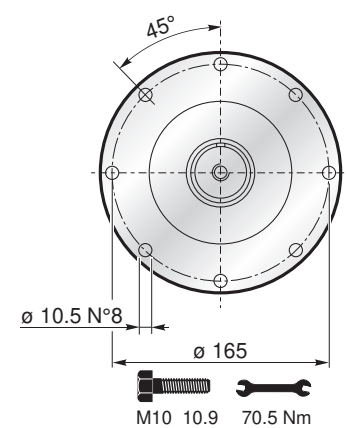
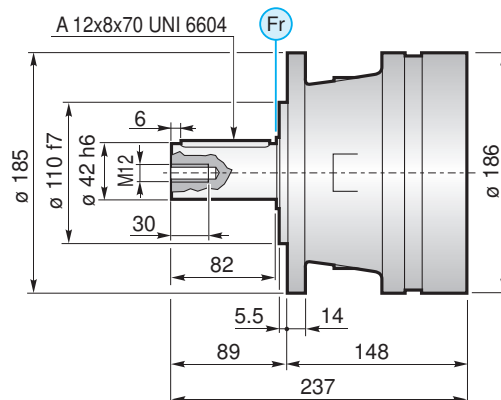

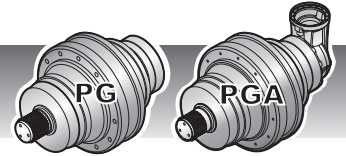

F

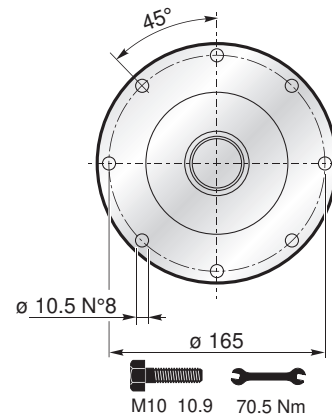
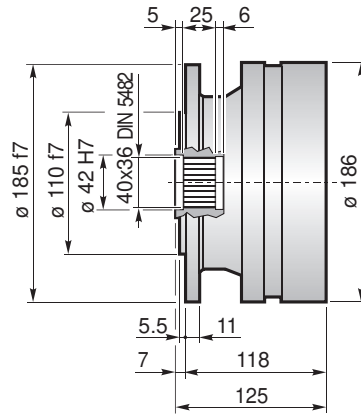
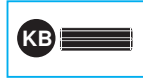

FS

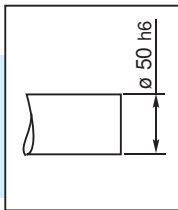
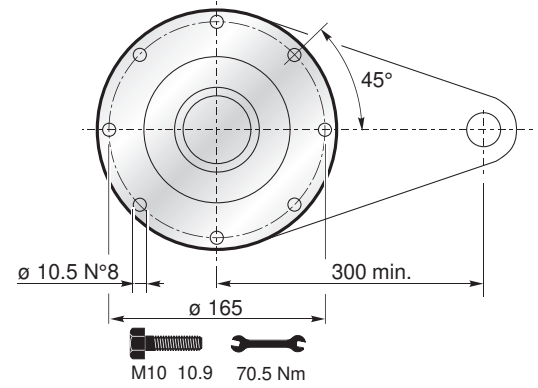
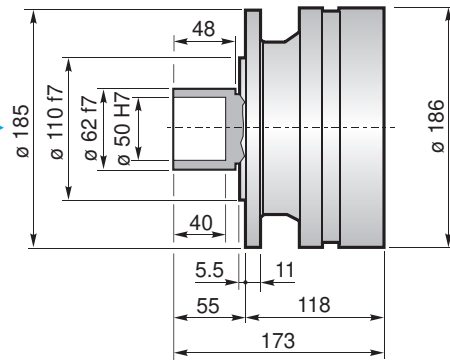

$M_{max} = 2.2 \text{ kNm}$

La coppia massima indicata è valida solo con calettatori forniti da Planetary Drives
 The maximum torque indicated is valid only with shrink discs supplied by Planetary Drives
 Das dargestellte, maximale Drehmoment gilt nur mit von Planetary Drives gelieferter Schrumpfscheibe
 Le couple maximal indiqué n'est valable qu'avec les frettes de serrage fournis par Planetary Drives
 El momento máximo indicado sólo es válido con discos de contracción suministrados por Planetary Drives
 O torque máximo indicado é válido exclusivamente com discos de contração fornecidos pela Planetary Drives

CPC

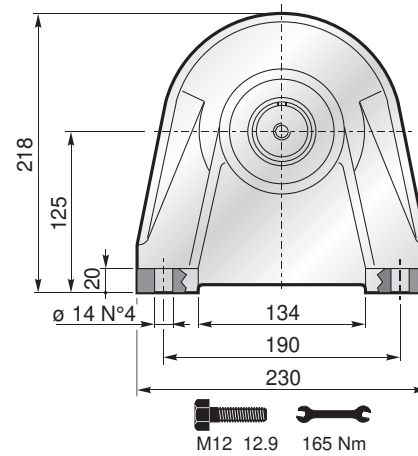
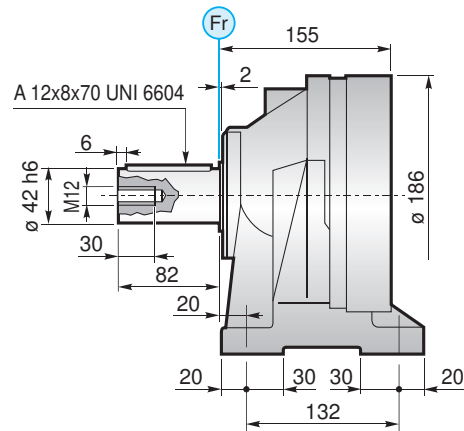

FL YZ BS FF KB GA → B-18



160

IT EN DE FR ES PT

	PG ...MS					
	A	B	RA	RB	EF	EDF
PG 161	118	180	•			•
PG 162	166	228	•			•
PG 163	214	276	•			•
PG 164	262	324	•			•

	PG ...MC					
	A	B	RA	RB	EF	EDF
PG 161	118	207	•			•
PG 162	166	255	•			•
PG 163	214	303	•			•
PG 164	262	351	•			•

	PG ...PS					
	A	B	RA	RB	EF	EDF
PG 161	148	210	•			•
PG 162	196	258	•			•
PG 163	244	306	•			•
PG 164	292	354	•			•

	PG ...PC					
	A	B	RA	RB	EF	EDF
PG 161	148	237	•			•
PG 162	196	285	•			•
PG 163	244	333	•			•
PG 164	292	381	•			•

	PG ...F					
	A	B	RA	RB	EF	EDF
PG 161	118	125	•			•
PG 162	166	173	•			•
PG 163	214	221	•			•
PG 164	262	269	•			•

	PG ...FS					
	A	B	RA	RB	EF	EDF
PG 161	118	173	•			•
PG 162	166	221	•			•
PG 163	214	269	•			•
PG 164	262	317	•			•

	PG ...CPC					
	A	B	RA	RB	EF	EDF
PG 161	155	237	•			•
PG 162	203	285	•			•
PG 163	251	333	•			•
PG 164	299	381	•			•

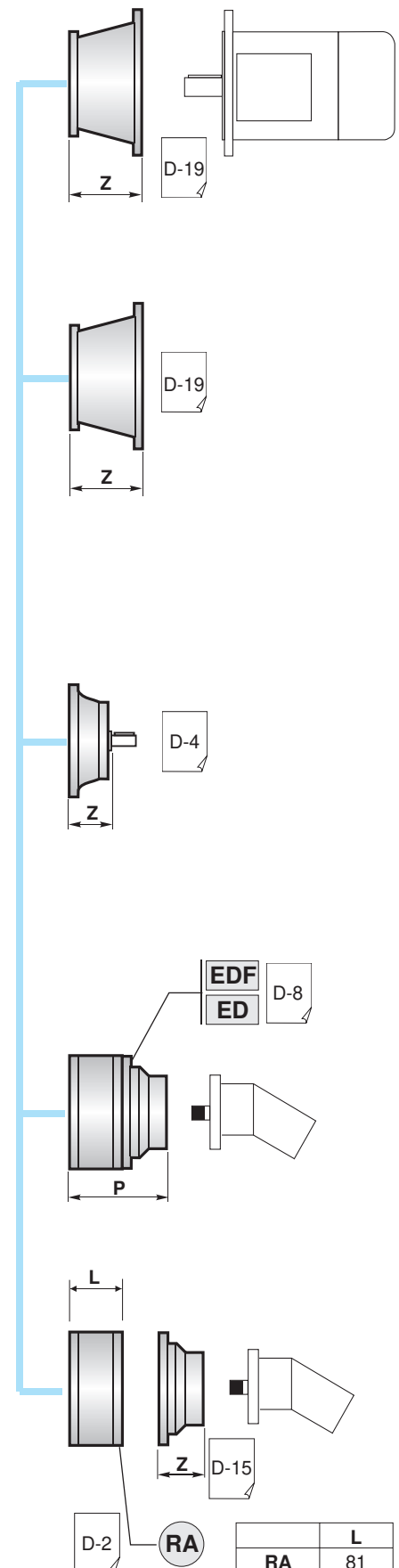

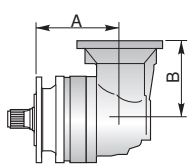

	PGA ...MS					
	A	B	RA	RB	EF	
PGA 162	193	159	•		•	
PGA 163	241	159	•		•	
PGA 164	289	159	•		•	

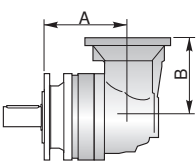
	PGA ...MC					
	A	B	RA	RB	EF	
PGA 162	193	159	•		•	
PGA 163	241	159	•		•	
PGA 164	289	159	•		•	

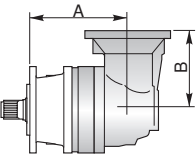
	PGA ...PS					
	A	B	RA	RB	EF	
PGA 162	223	159	•		•	
PGA 163	271	159	•		•	
PGA 164	319	159	•		•	

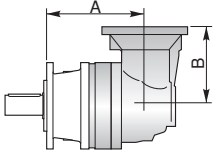
	PGA ...PC					
	A	B	RA	RB	EF	
PGA 162	223	159	•		•	
PGA 163	271	159	•		•	
PGA 164	319	159	•		•	

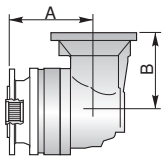
	PGA ...F					
	A	B	RA	RB	EF	
PGA 162	193	159	•		•	
PGA 163	241	159	•		•	
PGA 164	289	159	•		•	

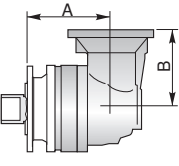
	PGA ...FS					
	A	B	RA	RB	EF	
PGA 162	193	159	•		•	
PGA 163	241	159	•		•	
PGA 164	289	159	•		•	

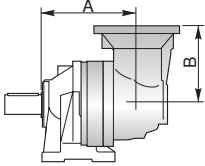
	PGA ...CPC					
	A	B	RA	RB	EF	
PGA 162	230	159	•		•	
PGA 163	278	159	•		•	
PGA 164	326	159	•		•	

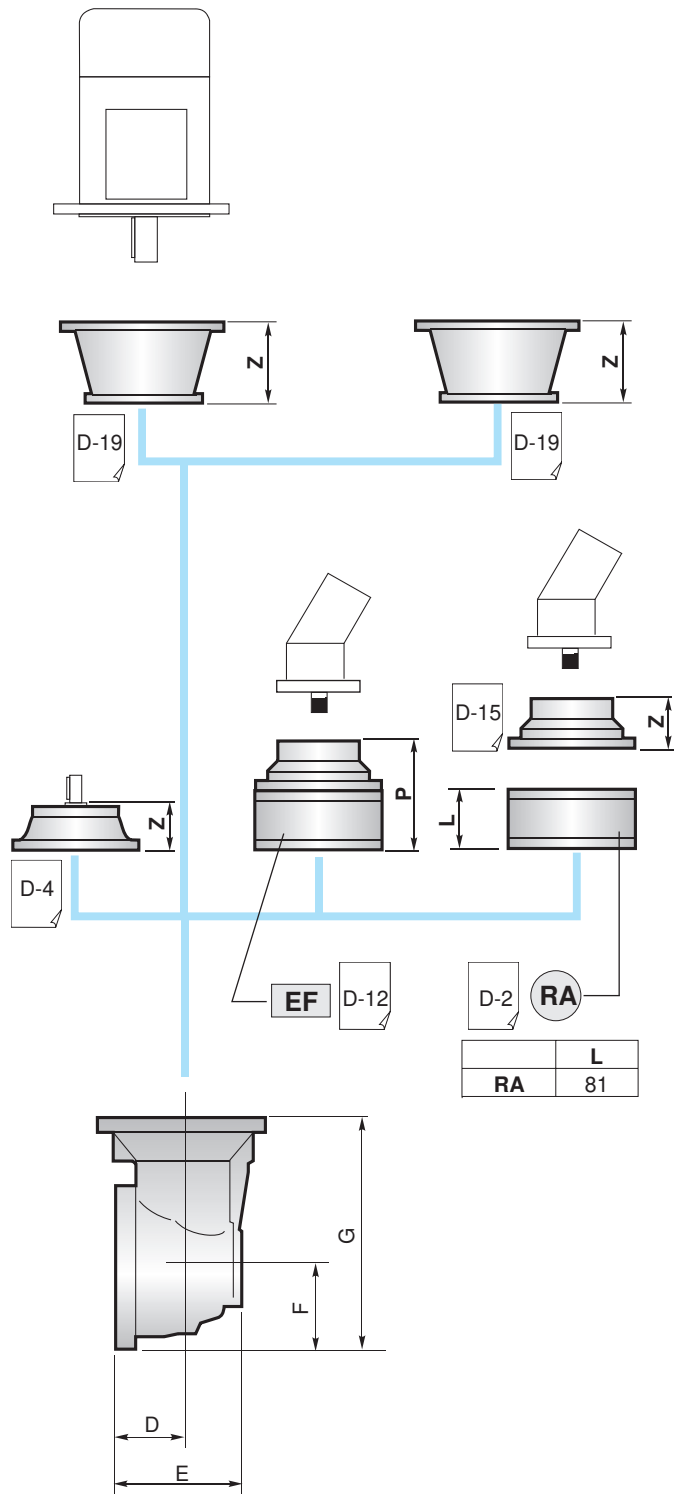

	D	E	F	G
PGA 162	75	141.5	93	252
PGA 163	75	141.5	93	252
PGA 164	75	141.5	93	252

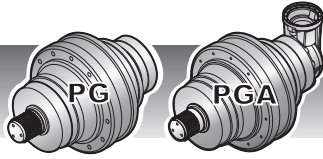

160

IT EN DE FR ES PT

YZ Pignoni / Pinion
Ritzel / Pignon
Piñones / Pinhões

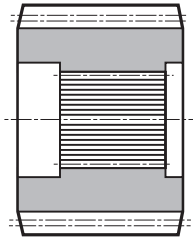

Su richiesta / On request
Auf Anfrage / Sur demande
Bajo demanda / Sob consulta

FF Fondello di arresto / Stop bottom plate
Endscheibe / Bouchon de fermeture
Tapón de detención / Fundo de batente

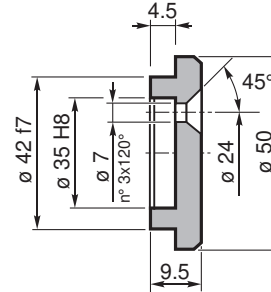

Codice / Code
Bestell - Nr. / Code
Código / Código
5701.034.000

BS Boccola scanalata / Splined bushing
Innenverzähnte Buchse / Moyeu cannelé
Casquillo ranurado / Bucha estriada

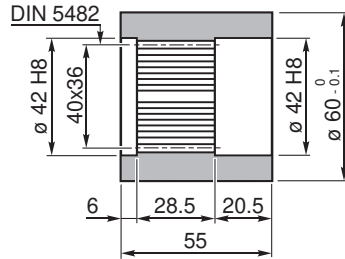

Materiale / Material
Material / Matière
Material / Material
UNI C40
SAE 1040
DIN Ck40

Codice / Code
Bestell - Nr. / Code
Código / Código
1710.100.076

KB Barra scanalata / Splined rod
Außenverzähnte Welle / Arbre cannelé
Barra ranurada / Barra estriada

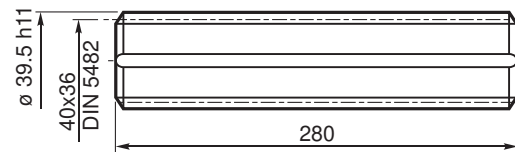

Materiale / Material
Material / Matière
Material / Material

UNI 39NiCrMo3
bonificato / hardened and tempered
vergütet / bonifié
bonificado / endurecido e temperado

Codice / Code
Bestell - Nr. / Code
Código / Código
1703.179.042

FL Flangia / Flange
Flansch / Bride
Brida / Flange

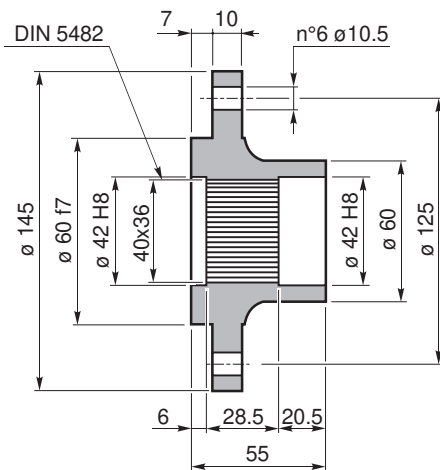

Codice / Code
Bestell - Nr. / Code
Código / Código
1710.102.025

GA Giunto di attrito / Shrink disc
Schrumpfscheibe / Frette de serrage
Disco de contracción / Disco de contração

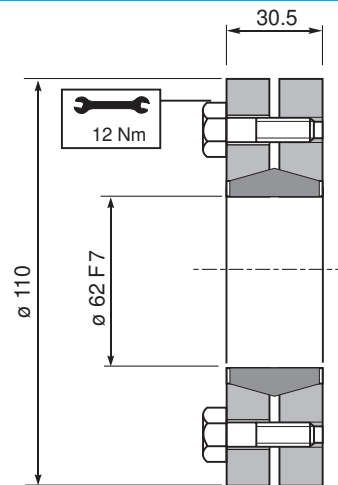

Coppia max.
Max. torque
Max. Drehmoment
Couple max.
Momento máx.
Torque máx.

2.2 kNm

Codice / Code
Bestell - Nr. / Code
Código / Código
9015.062.000

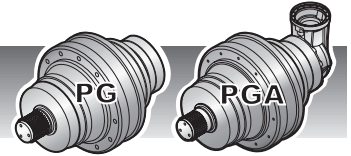

CARICHI RADIALI (Fr)

Nei diagrammi seguenti sono riportati i carichi radiali e i coefficienti K per rapportarli al valore $n_2 \times h$ desiderato.

RADIAL LOADS (Fr)

The following curves show the radial loads and the K factors to obtain the required $n_2 \times h$ value.

RADIALLAST (Fr)

In den nachstehenden Diagrammen ist die Radiallast und der Koeffizient K dargestellt und kann mit dem gewünschten Wert $n_2 \times h$ verglichen werden.

CHARGES RADIALES (Fr)

Dans les diagrammes suivants sont indiqués les charges radiales et les facteurs K de façon à obtenir la valeur $n_2 \times h$ désirée.

CARGAS RADIALES (Fr)

En los siguientes diagramas se indican las cargas radiales y los coeficientes K para obtener el valor requerido $n_2 \times h$.

CARGAS RADIAIS (Fr)

Nos diagramas seguintes são indicadas as cargas radiais e os coeficientes K para obter o valor $n_2 \times h$ desejado.

M - P - CPC*

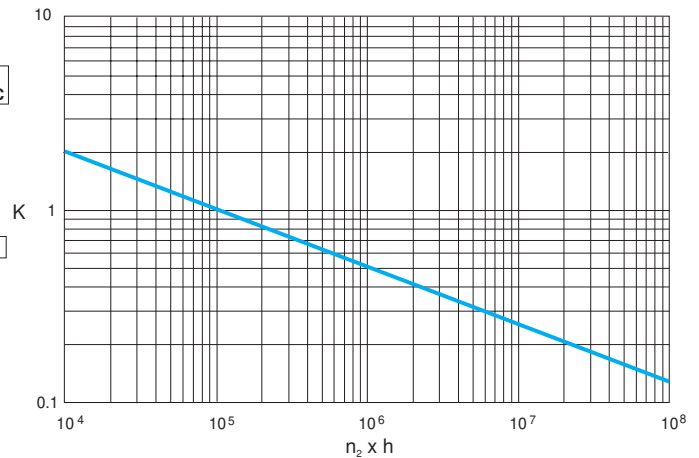
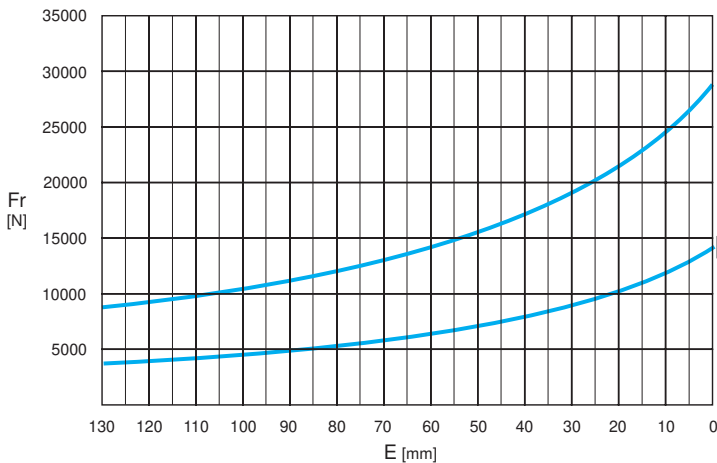

	$n_2 \times h$				
	10^5	10^4	10^6	10^7	10^8
M - P	Fr		Fr • K		
*CPC	Fr • 0.75		Fr • K • 0.75		

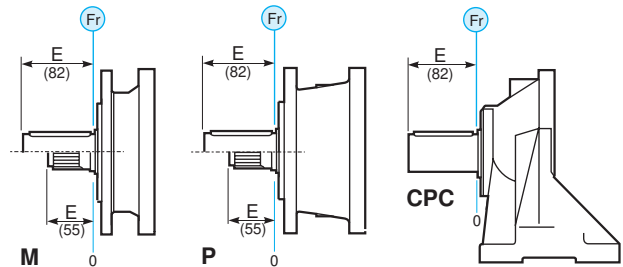

CARICHI ASSIALI (Fa)

I valori dei carichi assiali indicati in tabella sono riferiti alle versioni e alla direzione di applicazione del carico.

AXIAL LOADS (Fa)

The values of the axial loads in the table refer to the output versions and load direction of application.

AXIALLAST (Fa)

Die dargestellten Werte der Axiallast basieren auf der Version und der applizierten Lastrichtung.

CHARGES AXIALES (Fa)

Les valeurs des charges axiales indiquées dans le tableau se réfèrent aux versions et à la direction d'application de la charge.

CARGAS AXIALES (Fa)

Los valores de las cargas axiales indicados en la tabla se refieren a las versiones y a la dirección de aplicación de la carga.

CARGAS AXIAIS (Fa)

Os valores das cargas axiais indicadas na tabela referem-se às versões e à direção de aplicação da carga.

Fa [N]	M	P - CPC	← →
	16000	18000	

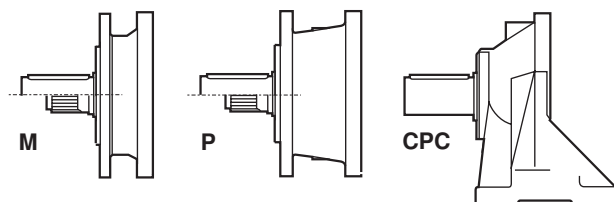



250

IT EN DE FR ES PT

	i	Mc [kNm]				n _{1max} [min ⁻¹]	Pt [kW]	Kg				
		n ₂ x h	n ₂ x h	n ₂ x h	n ₂ x h			M	P	CPC	F	FS
		10.000	20.000	50.000	100.000							
PG 251	3.78	3.98	3.52	3.00	2.65	2800	20	29	38	42	20	31
	4.13	3.60	3.19	2.71	2.40							
	5.17	3.01	2.66	2.26	2.00							
	6.00	2.52	2.23	1.90	1.68							
	7.25	1.95	1.73	1.47	1.30							
PG 252	13.43	3.60	3.20	2.73	2.41	2800	12	35	44	48	27	37
	16.19	3.60	3.20	2.73	2.41							
	18.37	3.01	2.66	2.26	2.00							
	23.10	2.81	2.50	2.13	1.88							
	28.93	3.01	2.66	2.26	2.00							
	34.88	2.97	2.63	2.26	1.99							
	40.50	2.52	2.23	1.90	1.68							
	48.94	1.95	1.73	1.47	1.30							
62.83	1.95	1.73	1.47	1.30								
PG 253	52.15	3.60	3.19	2.71	2.40	2800	8	41	50	54	32	43
	57.57	3.60	3.20	2.73	2.41							
	62.86	3.60	3.19	2.71	2.40							
	75.22	3.60	3.20	2.73	2.41							
	82.13	3.60	3.19	2.71	2.40							
	90.67	3.60	3.20	2.73	2.41							
	99.00	3.60	3.19	2.71	2.40							
	119.33	3.60	3.19	2.71	2.40							
	127.11	3.60	3.19	2.71	2.40							
	140.32	3.60	3.20	2.73	2.41							
	153.21	3.60	3.19	2.71	2.40							
	162.03	3.01	2.66	2.26	2.00							
	173.57	2.52	2.23	1.90	1.68							
	195.30	3.01	2.66	2.26	2.00							
	235.41	2.97	2.63	2.26	1.99							
	273.38	2.52	2.23	1.90	1.68							
	302.25	2.97	2.63	2.26	1.99							
351.00	2.52	2.23	1.90	1.68								
424.13	1.95	1.73	1.47	1.30								
PG 254	352.00	3.60	3.19	2.71	2.40	2800	4	47	56	60	38	49
	365.77	3.01	2.66	2.26	2.00							
	388.57	3.60	3.20	2.73	2.41							
	413.91	3.60	3.20	2.73	2.41							
	424.29	3.60	3.19	2.71	2.40							
	468.37	3.60	3.20	2.73	2.41							
	511.42	3.60	3.19	2.71	2.40							
	554.40	2.81	2.50	2.13	1.88							
	601.36	3.60	3.20	2.73	2.41							
	668.25	2.81	2.50	2.13	1.88							
	724.42	2.81	2.50	2.13	1.88							
	799.68	2.62	2.33	1.98	1.74							
	858.00	3.60	3.19	2.71	2.40							
	907.35	3.01	2.66	2.26	2.00							
	1034.20	3.60	3.19	2.71	2.40							
	1093.68	3.01	2.66	2.26	2.00							
	1318.28	3.01	2.66	2.26	2.00							
	1588.99	2.97	2.63	2.26	1.99							
	1845.28	2.52	2.23	1.90	1.68							
2369.25	2.52	2.23	1.90	1.68								



	i	Mc [kNm]				n _{1max} [min ⁻¹]	Pt [kW]	Kg				
		n ₂ x h	n ₂ x h	n ₂ x h	n ₂ x h			M	P	CPC	F	FS
		10.000	20.000	50.000	100.000							
PGA 252	12.08	2.63	2.57	2.48	2.43	2800	12	47	56	60	35	49
	15.13	3.27	3.19	3.09	2.87							
	17.57	3.77	3.34	2.84	2.52							
	21.23	2.95	2.61	2.22	1.97							
PGA 253	39.34	3.60	3.20	2.73	2.41	2800	8	53	62	66	45	55
	47.41	3.60	3.20	2.73	2.41							
	53.80	3.01	2.66	2.26	2.00							
	64.85	3.01	2.66	2.26	2.00							
	75.31	2.52	2.23	1.90	1.68							
	84.73	3.01	2.66	2.26	2.00							
	90.99	1.95	1.73	1.47	1.30							
	102.13	2.97	2.63	2.26	1.99							
	118.61	2.52	2.23	1.90	1.68							
	143.32	1.95	1.73	1.47	1.30							
	152.29	2.17	1.92	1.62	1.45							
	PGA 254	139.86	3.60	3.20	2.73							
168.59		3.60	3.20	2.73	2.41							
184.08		3.60	3.19	2.71	2.40							
221.88		3.60	3.19	2.71	2.40							
240.53		2.81	2.50	2.13	1.88							
267.76		2.52	2.23	1.90	1.68							
289.93		2.81	2.50	2.13	1.88							
322.74		2.52	2.23	1.90	1.68							
363.14		3.01	2.66	2.26	2.00							
421.71		2.52	2.23	1.90	1.68							
448.70		3.60	3.19	2.71	2.40							
474.51		3.01	2.66	2.26	2.00							
508.32		2.52	2.23	1.90	1.68							
551.04		2.52	2.23	1.90	1.68							
614.22		1.95	1.73	1.47	1.30							
664.20		2.52	2.23	1.90	1.68							
734.36		1.92	1.69	1.43	1.28							
800.60		2.52	2.23	1.90	1.68							
1027.93		2.17	1.92	1.62	1.45							
1242.08		1.95	1.73	1.47	1.30							
1319.81	2.17	1.92	1.62	1.45								



(n₂ x h = 20.000)

$$M_{\max} = M_c \times 2$$

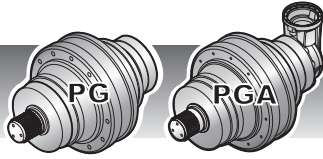

250

IT EN DE FR ES PT

MS

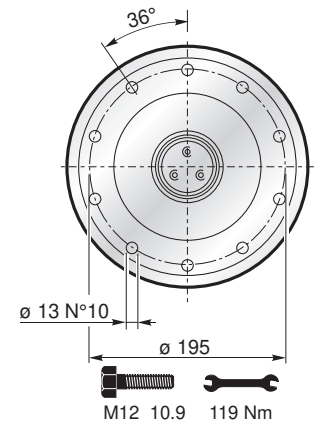
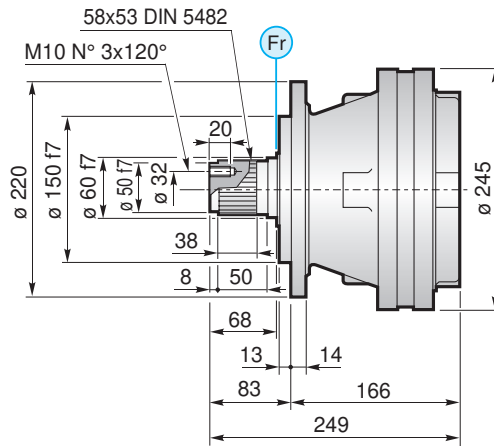
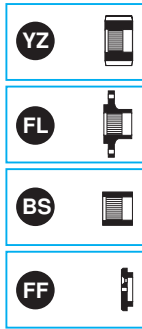

MC

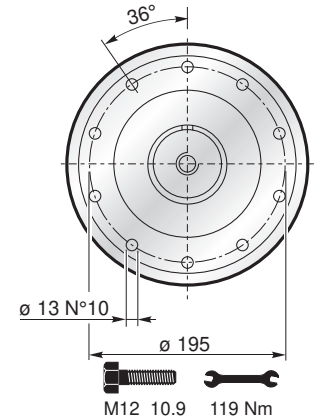
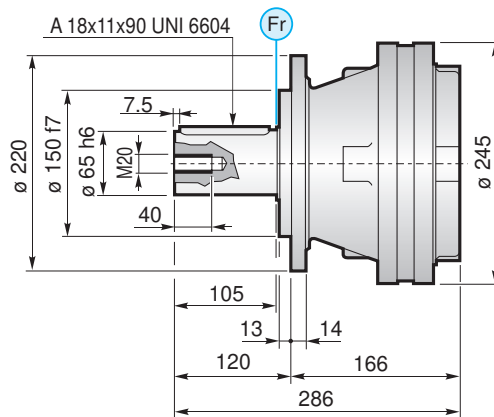

PS

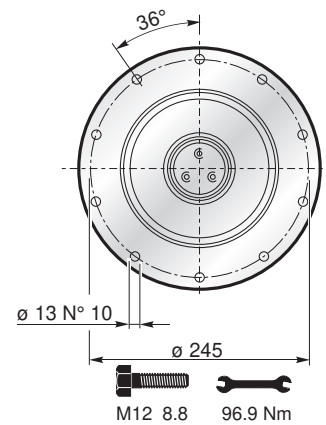
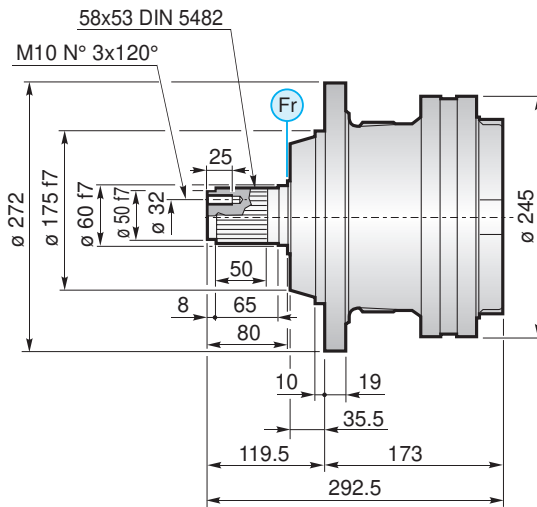
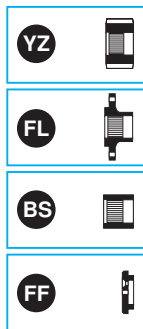

PC

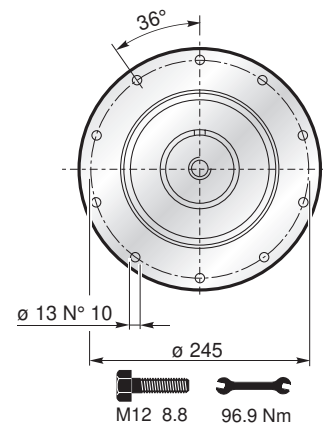
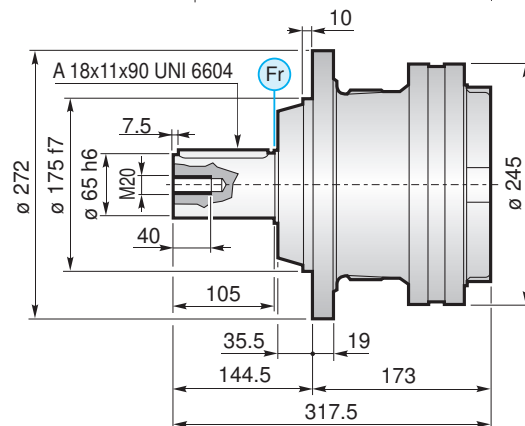

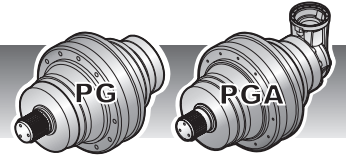

F

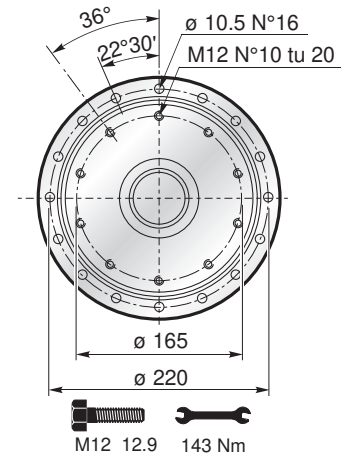
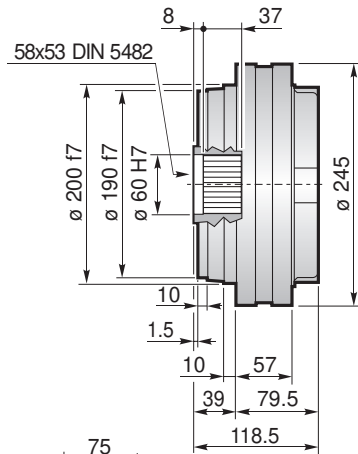

FS

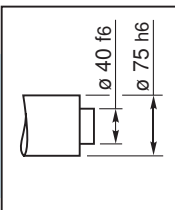
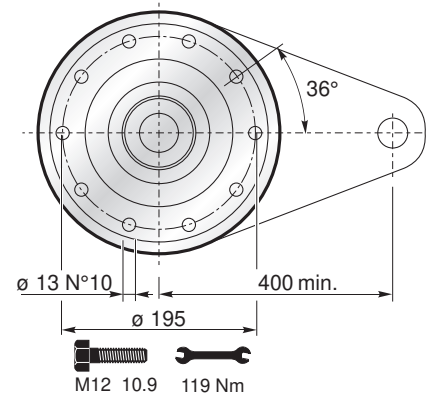
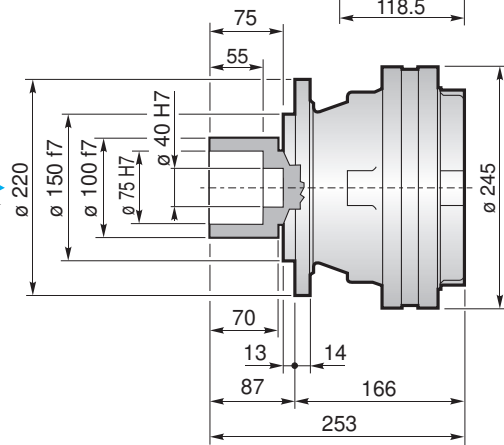

$M_{max} = 7.5 \text{ kNm}$

La coppia massima indicata è valida solo con calettatori forniti da Planetary Drives
 The maximum torque indicated is valid only with shrink discs supplied by Planetary Drives
 Das dargestellte, maximale Drehmoment gilt nur mit von Planetary Drives gelieferter Schrumpfscheibe
 Le couple maximal indiqué n'est valable qu'avec les frettes de serrage fournis par Planetary Drives
 El momento máximo indicado sólo es válido con discos de contracción suministrados por Planetary Drives
 O torque máximo indicado é válido exclusivamente com discos de contração fornecidos pela Planetary Drives

CPC

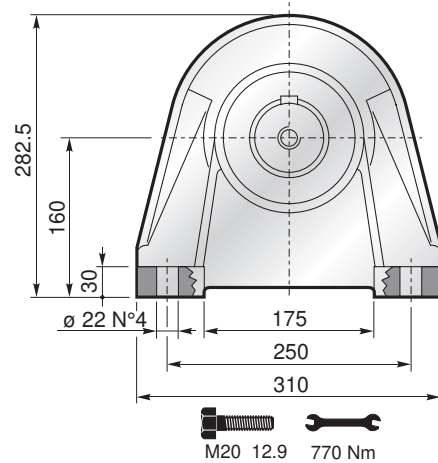
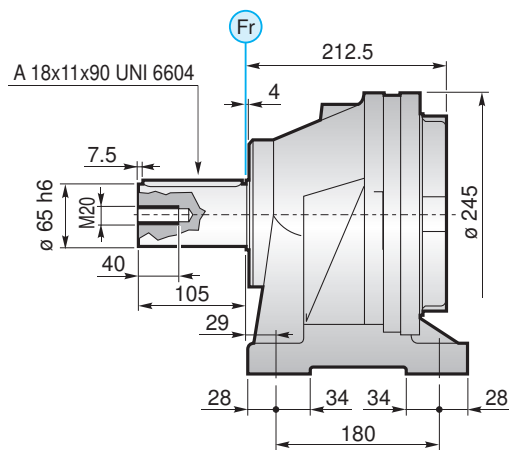

FL YZ BS FF KB GA → B-26



250

IT EN DE FR ES PT

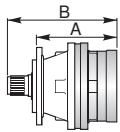
	PG ...MS					
	A	B	RA	RB	EF	EDF
PG 251	166	249	•	o	•	
PG 252	214	297	•			•
PG 253	262	345	•			•
PG 254	310	393	•			•

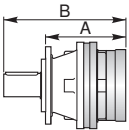
	PG ...MC					
	A	B	RA	RB	EF	EDF
PG 251	166	286	•	o	•	
PG 252	214	334	•			•
PG 253	262	382	•			•
PG 254	310	430	•			•

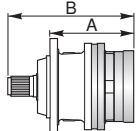
	PG ...PS					
	A	B	RA	RB	EF	EDF
PG 251	173	292.5	•	o	•	
PG 252	221	340.5	•			•
PG 253	269	388.5	•			•
PG 254	317	436.5	•			•

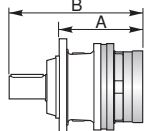
	PG ...PC					
	A	B	RA	RB	EF	EDF
PG 251	173	317.5	•	o	•	
PG 252	221	365.5	•			•
PG 253	269	413.5	•			•
PG 254	317	461.5	•			•

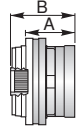
	PG ...F					
	A	B	RA	RB	EF	EDF
PG 251	79.5	118.5	•	o	•	
PG 252	127.5	166.5	•			•
PG 253	175.5	214.5	•			•
PG 254	223.5	262.5	•			•

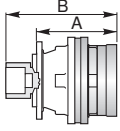
	PG ...FS					
	A	B	RA	RB	EF	EDF
PG 251	166	253	•	o	•	
PG 252	214	301	•			•
PG 253	262	349	•			•
PG 254	310	397	•			•

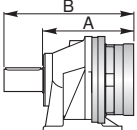
	PG ...CPC					
	A	B	RA	RB	EF	EDF
PG 251	212.5	317.5	•	o	•	
PG 252	260.5	365.5	•			•
PG 253	308.5	413.5	•			•
PG 254	356.5	461.5	•			•

	A+13.5	B+13.5	o
---	--------	--------	---

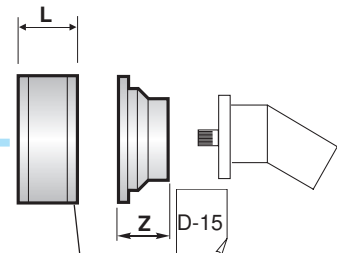
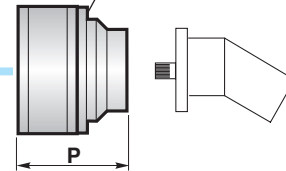
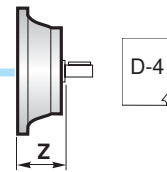
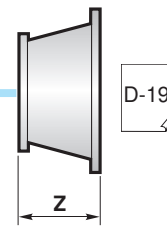
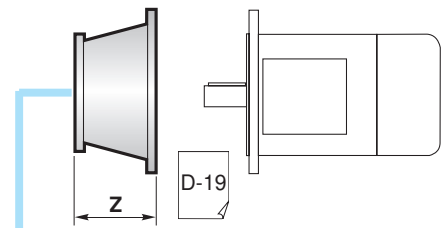

D-2	RA	RB	L
	RA	RB	81
	RA	RB	125

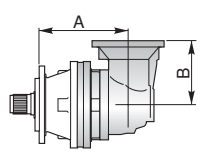

	PGA ...MS		RA	RB	EF
	A	B			
PGA 252	241	159	•		•
PGA 253	289	159	•		•
PGA 254	337	159	•		•

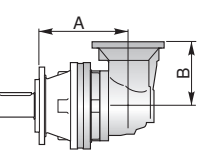
	PGA ...MC		RA	RB	EF
	A	B			
PGA 252	241	159	•		•
PGA 253	289	159	•		•
PGA 254	337	159	•		•

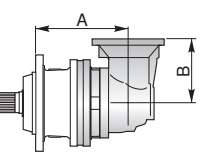
	PGA ...PS		RA	RB	EF
	A	B			
PGA 252	248	159	•		•
PGA 253	296	159	•		•
PGA 254	344	159	•		•

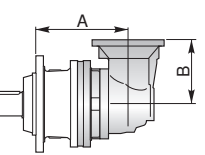
	PGA ...PC		RA	RB	EF
	A	B			
PGA 252	248	159	•		•
PGA 253	296	159	•		•
PGA 254	344	159	•		•

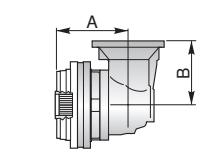
	PGA ...F		RA	RB	EF
	A	B			
PGA 252	192	159	•		•
PGA 253	240	159	•		•
PGA 254	288	159	•		•

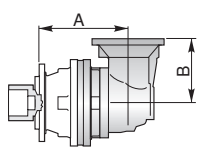
	PGA ...FS		RA	RB	EF
	A	B			
PGA 252	241	159	•		•
PGA 253	289	159	•		•
PGA 254	337	159	•		•

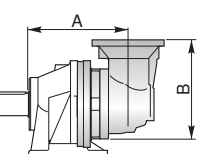
	PGA ...CPC		RA	RB	EF
	A	B			
PGA 252	287.5	159	•		•
PGA 253	335.5	159	•		•
PGA 254	383.5	159	•		•

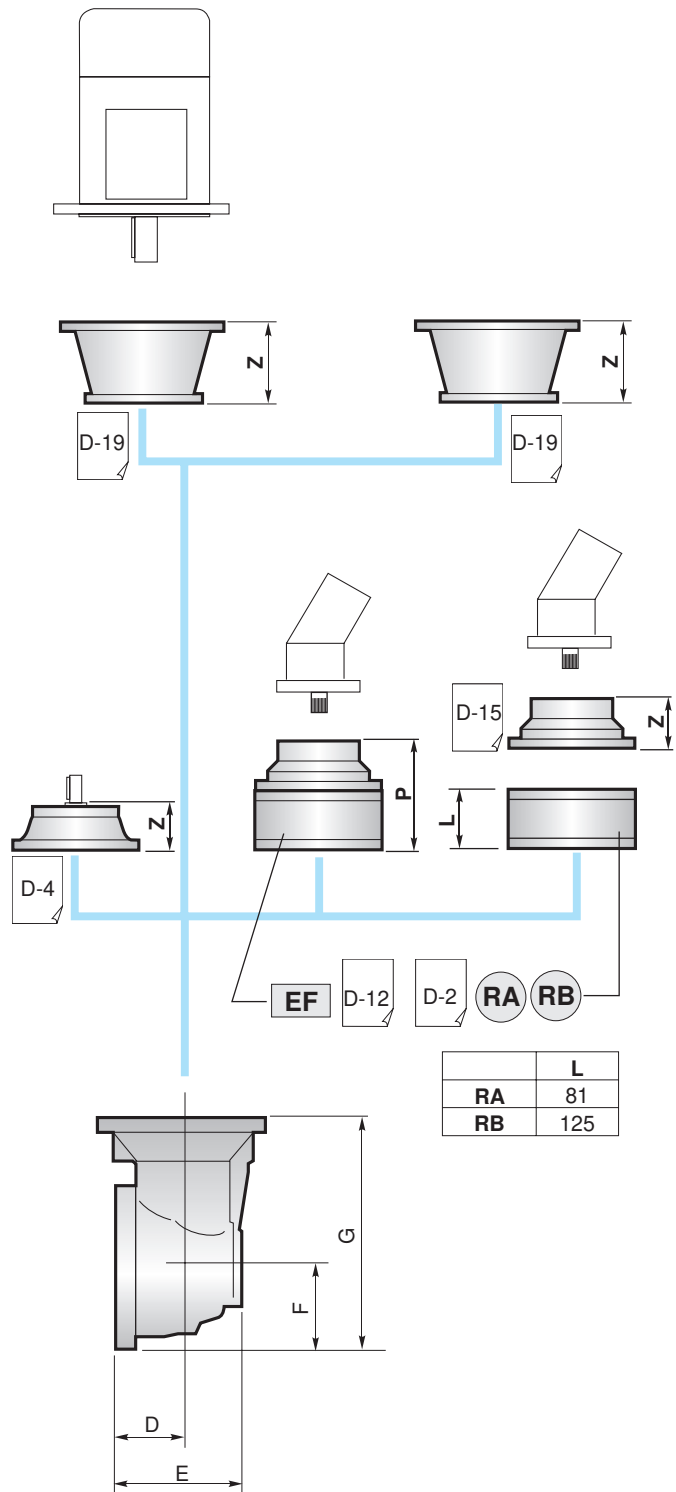

	D	E	F	G
PGA 252	75	141.5	93	252
PGA 253	75	141.5	93	252
PGA 254	75	141.5	93	252

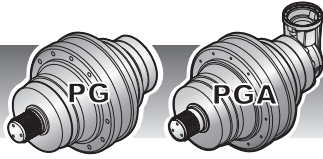

250

IT EN DE FR ES PT

YZ Pignoni / Pinion
Ritzel / Pignon
Piñones / Pinhões

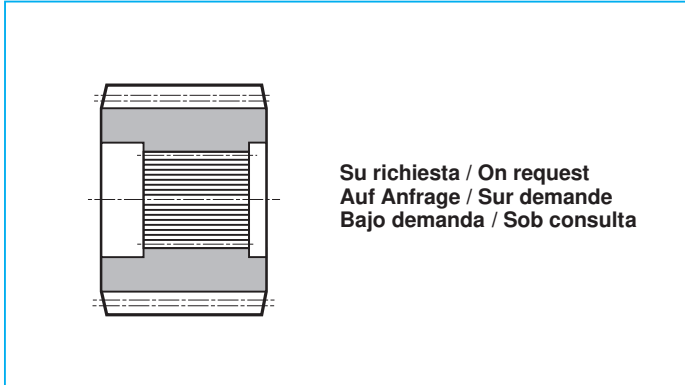

Su richiesta / On request
Auf Anfrage / Sur demande
Bajo demanda / Sob consulta

FF Fondello di arresto / Stop bottom plate
Endscheibe / Bouchon de fermeture
Tapón de detención / Fundo de batente

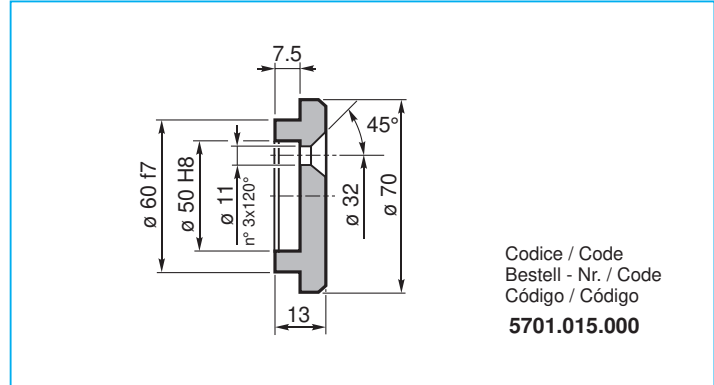

Codice / Code
Bestell - Nr. / Code
Código / Código
5701.015.000

BS Boccola scanalata / Splined bushing
Innenverzähnte Buchse / Moyeu cannelé
Casquillo ranurado / Bucha estriada

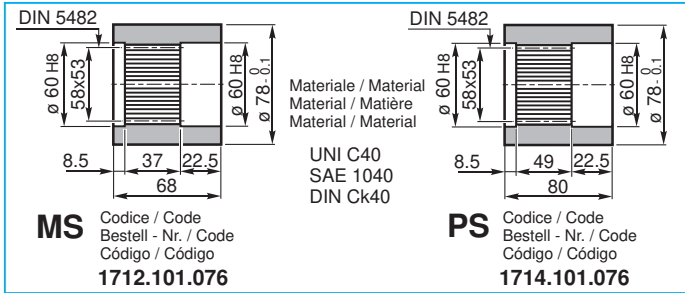

KB Barra scanalata / Splined rod
Außenverzähnte Welle / Arbre cannelé
Barra ranurada / Barra estriada

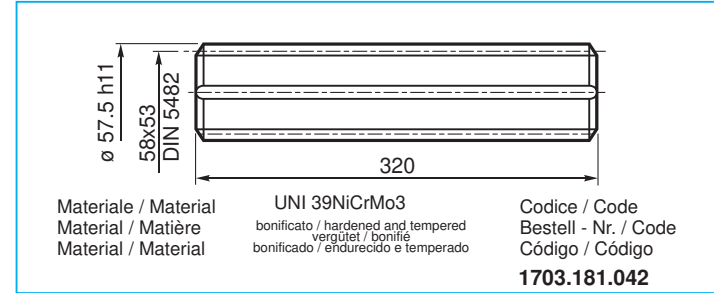

FL Flangia / Flange
Flansch / Bride
Brida / Flange

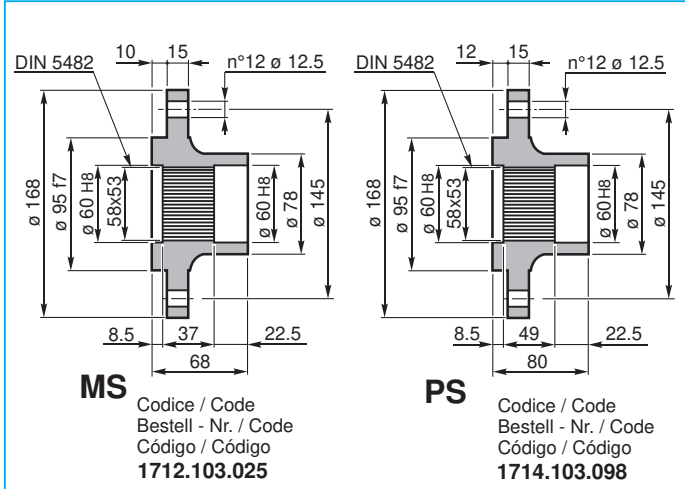

GA Giunto di attrito / Shrink disc
Schrumpfscheibe / Frette de serrage
Disco de contracción / Disco de contração

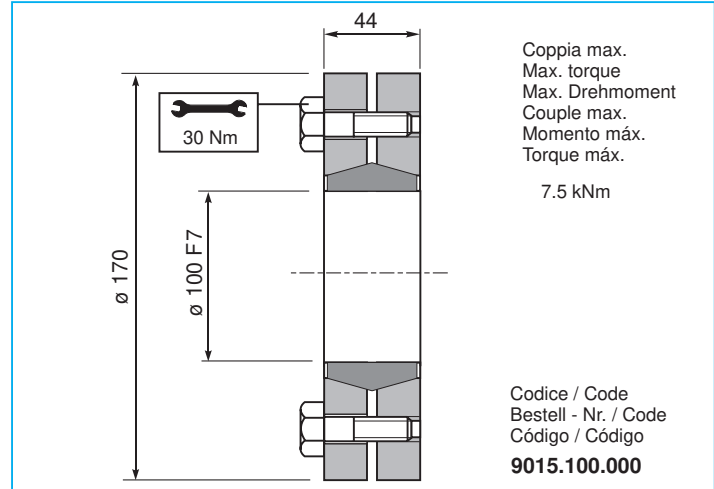

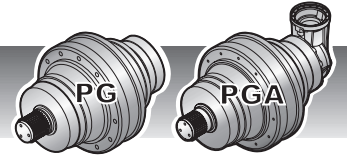

CARICHI RADIALI (Fr)

Nei diagrammi seguenti sono riportati i carichi radiali e i coefficienti K per rapportarli al valore $n_2 \times h$ desiderato.

RADIAL LOADS (Fr)

The following curves show the radial loads and the K factors to obtain the required $n_2 \times h$ value.

RADIALLAST (Fr)

In den nachstehenden Diagrammen ist die Radiallast und der Koeffizient K dargestellt und kann mit dem gewünschten Wert $n_2 \times h$ verglichen werden.

CHARGES RADIALES (Fr)

Dans les diagrammes suivants sont indiqués les charges radiales et les facteurs K de façon à obtenir la valeur $n_2 \times h$ désirée.

CARGAS RADIALES (Fr)

En los siguientes diagramas se indican las cargas radiales y los coeficientes K para obtener el valor requerido $n_2 \times h$.

CARGAS RADIAIS (Fr)

Nos diagramas seguintes são indicadas as cargas radiais e os coeficientes K para obter o valor $n_2 \times h$ desejado.

M - P - CPC*

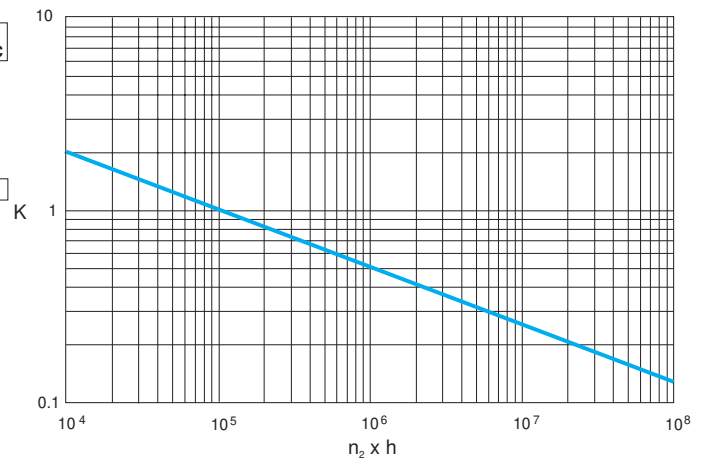
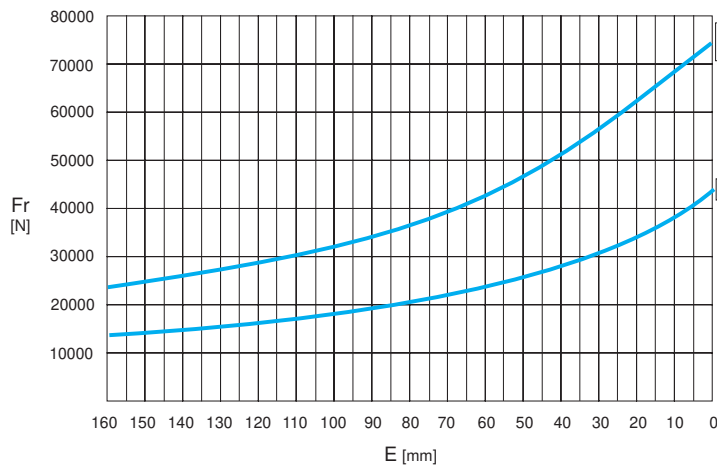

	$n_2 \times h$				
	10^5	10^4	10^6	10^7	10^8
M - P	Fr				Fr • K
*CPC	Fr • 0.75				Fr • K • 0.75

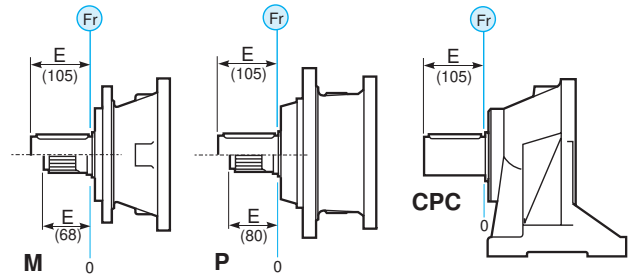

CARICHI ASSIALI (Fa)

I valori dei carichi assiali indicati in tabella sono riferiti alle versioni e alla direzione di applicazione del carico.

AXIAL LOADS (Fa)

The values of the axial loads in the table refer to the output versions and load direction of application.

AXIALLAST (Fa)

Die dargestellten Werte der Axiallast basieren auf der Version und der applizierten Lastrichtung.

CHARGES AXIALES (Fa)

Les valeurs des charges axiales indiquées dans le tableau se réfèrent aux versions et à la direction d'application de la charge.

CARGAS AXIALES (Fa)

Los valores de las cargas axiales indicados en la tabla se refieren a las versiones y a la dirección de aplicación de la carga.

CARGAS AXIAIS (Fa)

Os valores das cargas axiais indicadas na tabela referem-se às versões e à direção de aplicação da carga.

Fa [N]	M	P - CPC	
		32000	32000
	32000	48000	→

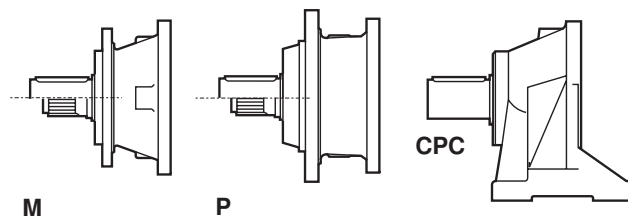



500

IT EN DE FR ES PT

	i	Mc [kNm]				n _{1max} [min ⁻¹]	Pt [kW]	Kg				
		n ₂ x h	n ₂ x h	n ₂ x h	n ₂ x h			M	P	CPC	F	FS
		10.000	20.000	50.000	100.000							
PG 501	3.78	5.77	5.11	4.35	3.85	2800	20	33	42	46	25	35
	4.13	5.26	4.66	3.97	3.51							
	5.17	4.30	3.81	3.24	2.87							
	6.00	3.77	3.34	2.84	2.52							
	7.25	2.95	2.61	2.22	1.97							
PG 502	13.43	5.57	4.93	4.20	3.71	2800	15	41	50	54	32	43
	16.19	5.57	4.93	4.20	3.71							
	18.37	4.30	3.81	3.24	2.87							
	23.10	4.27	3.77	3.21	2.84							
	28.93	4.30	3.81	3.24	2.87							
	34.88	4.24	3.75	3.19	2.81							
	40.50	3.77	3.34	2.84	2.52							
	48.94	2.95	2.61	2.22	1.97							
PG 503	52.15	5.26	4.66	3.97	3.51	2800	10	47	56	60	38	49
	57.57	5.57	4.93	4.20	3.71							
	62.86	5.26	4.66	3.97	3.51							
	75.22	5.57	4.93	4.20	3.71							
	82.13	5.26	4.66	3.97	3.51							
	90.67	5.57	4.93	4.20	3.71							
	99.00	5.26	4.66	3.97	3.51							
	119.33	5.26	4.66	3.97	3.51							
	129.36	4.27	3.77	3.21	2.84							
	140.32	4.78	4.22	3.56	3.19							
	153.21	5.14	4.54	3.83	3.43							
	162.03	4.30	3.81	3.24	2.87							
	173.57	3.77	3.34	2.84	2.52							
	195.30	4.30	3.81	3.24	2.87							
	235.41	4.24	3.75	3.19	2.81							
	273.38	3.77	3.34	2.84	2.52							
	302.25	4.24	3.75	3.19	2.81							
	351.00	3.77	3.34	2.84	2.52							
PG 504	365.77	4.30	3.81	3.24	2.87	2800	6	53	62	66	44	55
	388.57	5.57	4.93	4.20	3.71							
	413.91	5.57	4.93	4.20	3.71							
	424.29	5.26	4.66	3.97	3.51							
	468.37	5.57	4.93	4.20	3.71							
	511.42	5.26	4.66	3.97	3.51							
	554.40	4.27	3.77	3.21	2.84							
	601.36	5.57	4.93	4.20	3.71							
	656.63	5.26	4.66	3.97	3.51							
	711.82	4.41	3.89	3.28	2.94							
	785.78	4.78	4.22	3.56	3.19							
	822.45	4.30	3.81	3.24	2.87							
	858.00	5.14	4.54	3.83	3.43							
	907.35	4.30	3.81	3.24	2.87							
	1034.20	5.14	4.54	3.83	3.43							
	1216.08	4.78	4.22	3.56	3.19							
	1327.86	5.14	4.54	3.83	3.43							
	1588.99	4.24	3.75	3.19	2.81							
	1735.07	4.27	3.77	3.21	2.84							



	i	Mc [kNm]				n _{1max} [min ⁻¹]	Pt [kW]	Kg				
		n ₂ x h	n ₂ x h	n ₂ x h	n ₂ x h			M	P	CPC	F	FS
		10.000	20.000	50.000	100.000							
PGA 502	13.05	5.77	5.11	4.35	3.85	2800	15	51	60	64	43	53
	14.25	5.26	4.66	3.97	3.51							
	17.85	4.30	3.81	3.24	2.87							
	20.73	3.77	3.34	2.84	2.52							
	22.46	3.70	3.45	3.15	2.94							
	28.13	4.30	3.81	3.24	2.87							
	32.67	3.77	3.34	2.84	2.52							
	39.47	2.95	2.61	2.22	1.97							
PGA 503	39.34	5.57	4.93	4.20	3.71	2800	10	59	68	72	50	61
	47.41	5.57	4.93	4.20	3.71							
	53.80	4.30	3.81	3.24	2.87							
	67.65	4.27	3.77	3.21	2.84							
	75.31	3.77	3.34	2.84	2.52							
	84.73	4.30	3.81	3.24	2.87							
	90.99	2.95	2.61	2.22	1.97							
	102.13	4.24	3.75	3.19	2.81							
	118.61	3.77	3.34	2.84	2.52							
	143.32	2.95	2.61	2.22	1.97							
PGA 504	139.86	5.57	4.93	4.20	3.71	2800	6	65	74	78	56	67
	168.59	5.57	4.93	4.20	3.71							
	184.08	5.26	4.66	3.97	3.51							
	221.88	5.26	4.66	3.97	3.51							
	240.53	4.27	3.77	3.21	2.84							
	267.76	3.77	3.34	2.84	2.52							
	289.93	4.27	3.77	3.21	2.84							
	322.74	3.77	3.34	2.84	2.52							
	346.95	3.97	3.51	2.99	2.64							
	410.93	4.78	4.22	3.56	3.19							
	448.70	5.14	4.54	3.83	3.43							
	474.51	4.30	3.81	3.24	2.87							
	508.32	3.77	3.34	2.84	2.52							
	536.95	3.97	3.51	2.99	2.64							
	571.95	4.30	3.81	3.24	2.87							
	652.65	3.77	3.34	2.84	2.52							
	734.36	4.30	3.81	3.24	2.87							
	885.16	4.24	3.75	3.19	2.81							
1027.93	3.77	3.34	2.84	2.52								
1242.08	2.95	2.61	2.22	1.97								

500



(n₂ x h = 20.000)

$$M_{\max} = M_c \times 2$$

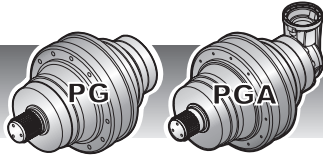

500

IT EN DE FR ES PT

MS

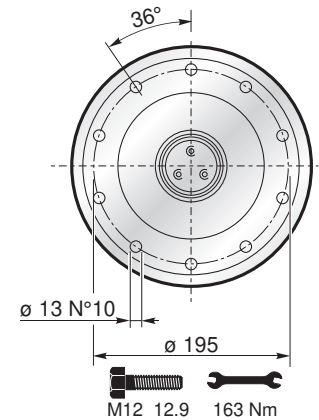
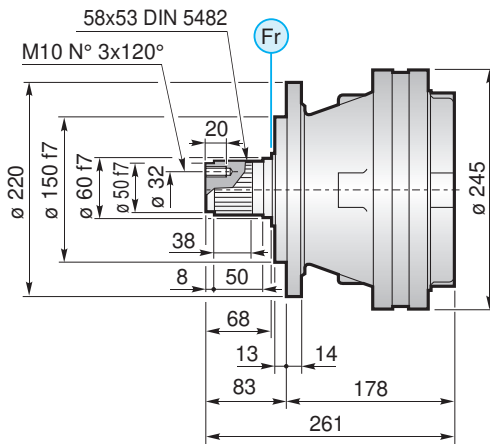
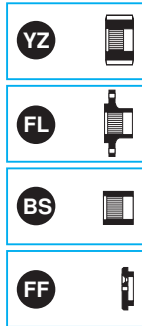

MC

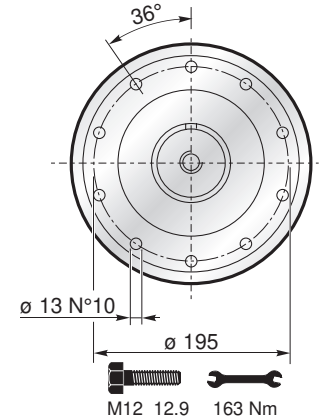
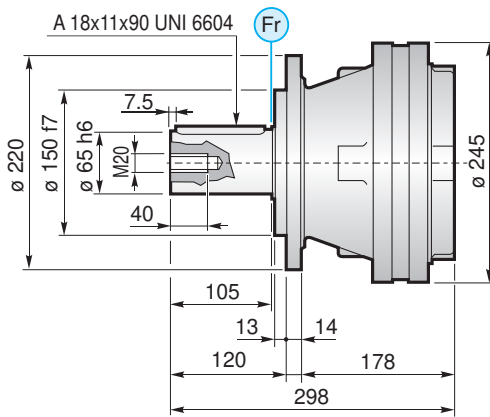

PS

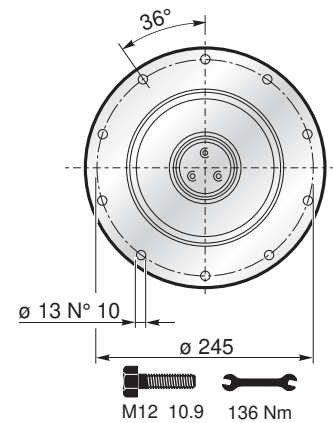
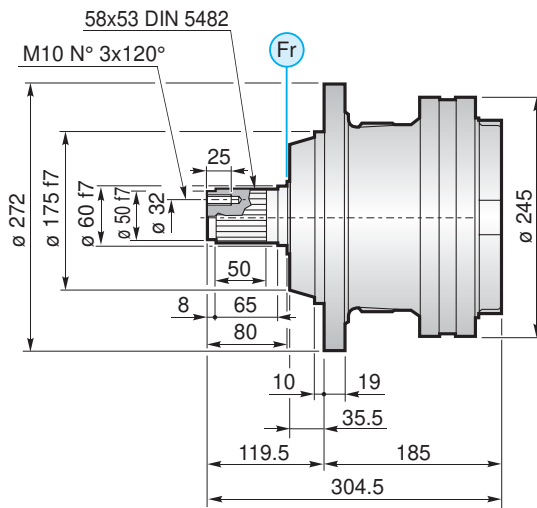
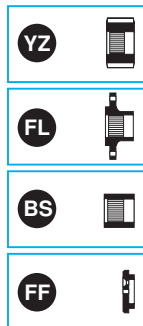

PC

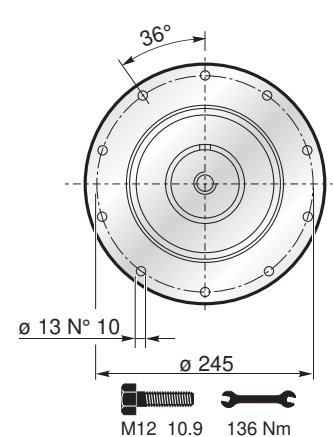
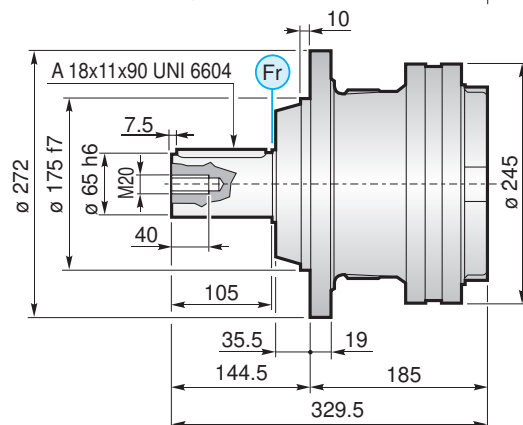

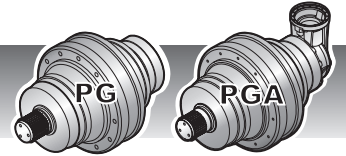

F

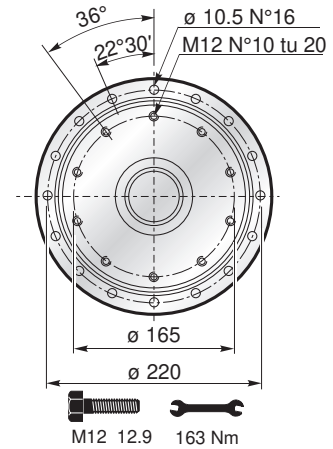
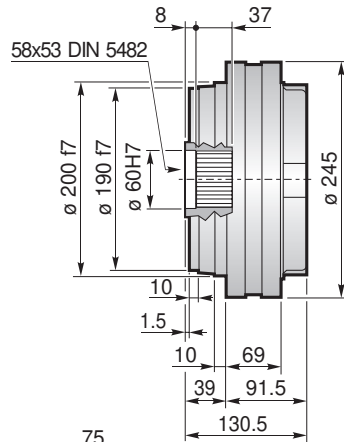
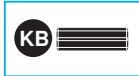

FS

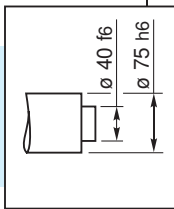
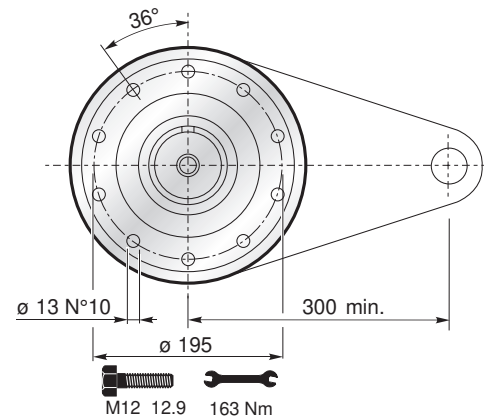
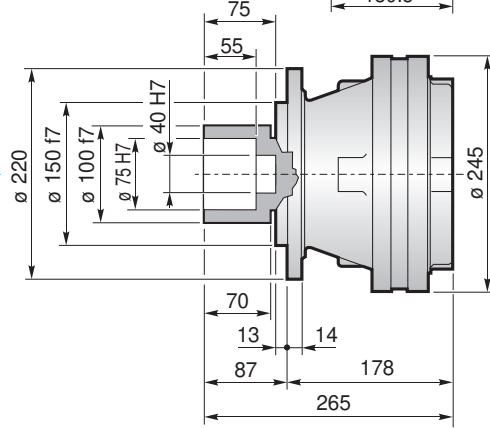

$M_{max} = 7.5 \text{ kNm}$

La coppia massima indicata è valida solo con calettatori forniti da Planetary Drives
 The maximum torque indicated is valid only with shrink discs supplied by Planetary Drives
 Das dargestellte, maximale Drehmoment gilt nur mit von Planetary Drives gelieferter Schrumpfscheibe
 Le couple maximal indiqué n'est valable qu'avec les frettes de serrage fournis par Planetary Drives
 El momento máximo indicado sólo es válido con discos de contracción suministrados por Planetary Drives
 O torque máximo indicado é válido exclusivamente com discos de contração fornecidos pela Planetary Drives

CPC

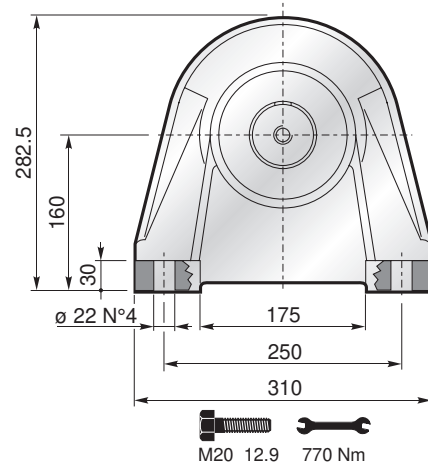
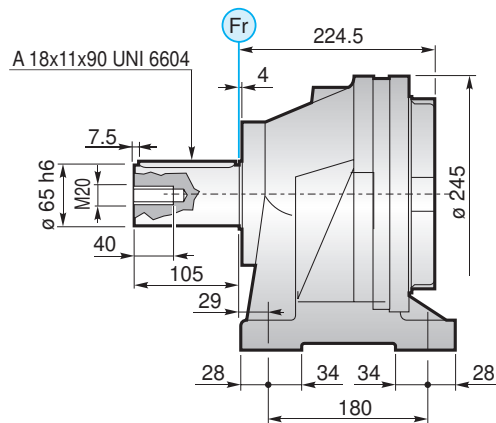

FL YZ BS FF KB GA → B-34



500

IT EN DE FR ES PT

PG	...MS					
	A	B	RA	RB	EF	EDF
PG 501	178	261	•	o	•	
PG 502	239	322	•			•
PG 503	287	370	•			•
PG 504	335	418	•			•

PG	...MC					
	A	B	RA	RB	EF	EDF
PG 501	178	298	•	o	•	
PG 502	239	359	•			•
PG 503	287	407	•			•
PG 504	335	455	•			•

PG	...PS					
	A	B	RA	RB	EF	EDF
PG 501	185	304.5	•	o	•	
PG 502	246	365.5	•			•
PG 503	294	413.5	•			•
PG 504	342	461.5	•			•

PG	...PC					
	A	B	RA	RB	EF	EDF
PG 501	185	329.5	•	o	•	
PG 502	246	390.5	•			•
PG 503	294	438.5	•			•
PG 504	342	486.5	•			•

PG	...F					
	A	B	RA	RB	EF	EDF
PG 501	91.5	130.5	•	o	•	
PG 502	152.5	191.5	•			•
PG 503	200.5	239.5	•			•
PG 504	248.5	287.5	•			•

PG	...FS					
	A	B	RA	RB	EF	EDF
PG 501	178	265	•	o	•	
PG 502	239.5	326	•			•
PG 503	287	374	•			•
PG 504	335	422	•			•

PG	...CPC					
	A	B	RA	RB	EF	EDF
PG 501	224.5	329.5	•	o	•	
PG 502	285.5	390.5	•			•
PG 503	333.5	438.5	•			•
PG 504	381.5	486.5	•			•



A+13.5	B+13.5	o
--------	--------	---

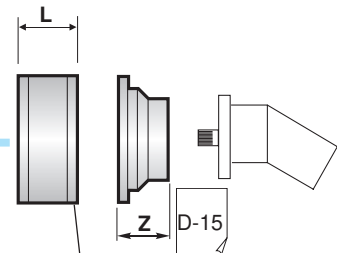
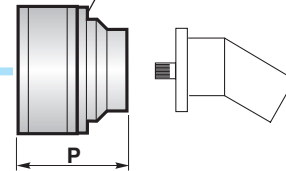
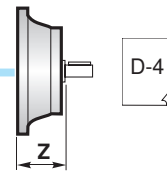
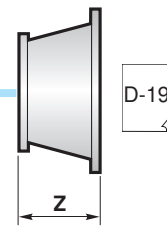
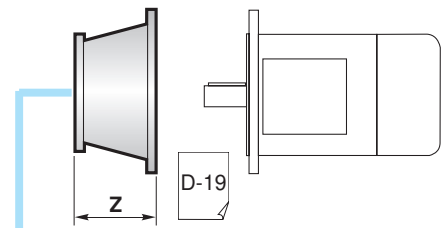

D-2	RA	RB	L
	RA	RB	81 125



	PGA ...MS		RA	RB	EF
	A	B			
PGA 502	279.5	240	•		•
PGA 503	314	159	•		•
PGA 504	362	159	•		•

	PGA ...MC		RA	RB	EF
	A	B			
PGA 502	279.5	240	•		•
PGA 503	314	159	•		•
PGA 504	362	159	•		•

	PGA ...PS		RA	RB	EF
	A	B			
PGA 502	286.5	240	•		•
PGA 503	321	159	•		•
PGA 504	369	159	•		•

	PGA ...PC		RA	RB	EF
	A	B			
PGA 502	286.5	240	•		•
PGA 503	321	159	•		•
PGA 504	369	159	•		•

	PGA ...F		RA	RB	EF
	A	B			
PGA 502	193	240	•		•
PGA 503	227.5	159	•		•
PGA 504	275.5	159	•		•

	PGA ...FS		RA	RB	EF
	A	B			
PGA 502	279.5	240	•		•
PGA 503	314	159	•		•
PGA 504	362	159	•		•

	PGA ...CPC		RA	RB	EF
	A	B			
PGA 502	326	240	•		•
PGA 503	360.5	159	•		•
PGA 504	408.5	159	•		•

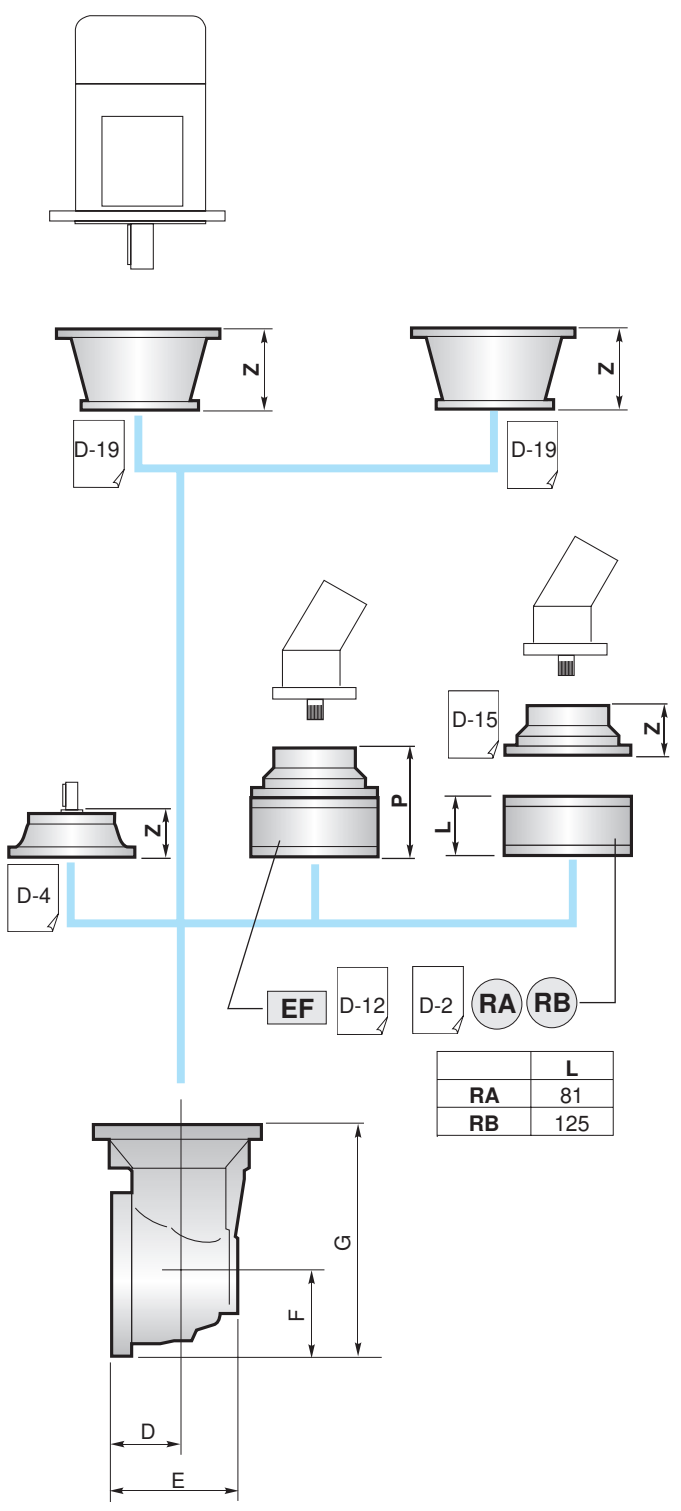

	L
RA	81
RB	125

	D	E	F	G
PGA 502	88	164	140	380
PGA 503	75	141.5	93	252
PGA 504	75	141.5	93	252

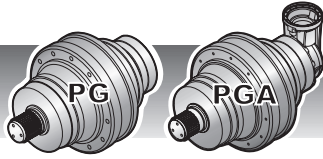

500

IT EN DE FR ES PT

YZ Pignoni / Pinion
Ritzel / Pignon
Piñones / Pinhões

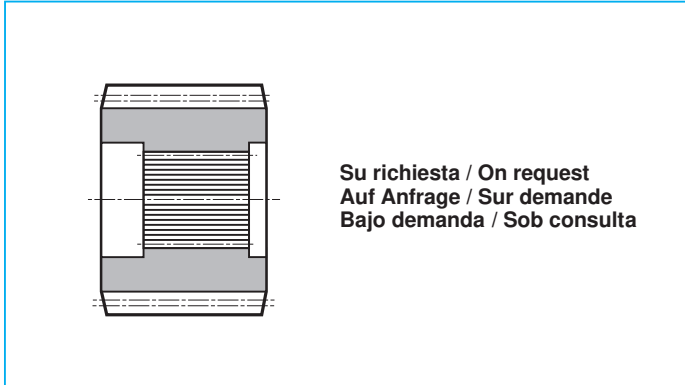

Su richiesta / On request
Auf Anfrage / Sur demande
Bajo demanda / Sob consulta

FF Fondello di arresto / Stop bottom plate
Endscheibe / Bouchon de fermeture
Tapón de detención / Fundo de batente

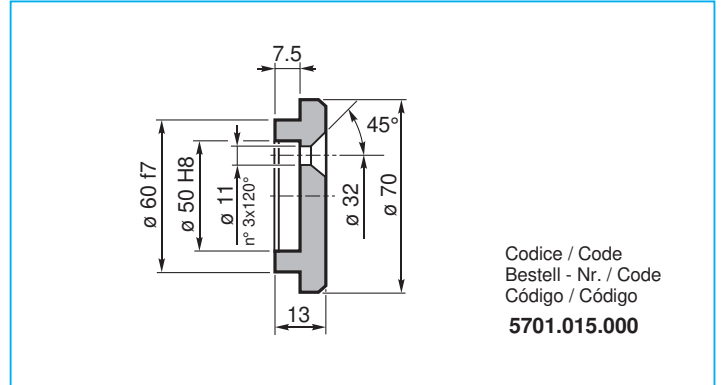

Codice / Code
Bestell - Nr. / Code
Código / Código
5701.015.000

BS Boccola scanalata / Splined bushing
Innenverzähnte Buchse / Moyeu cannelé
Casquillo ranurado / Bucha estriada

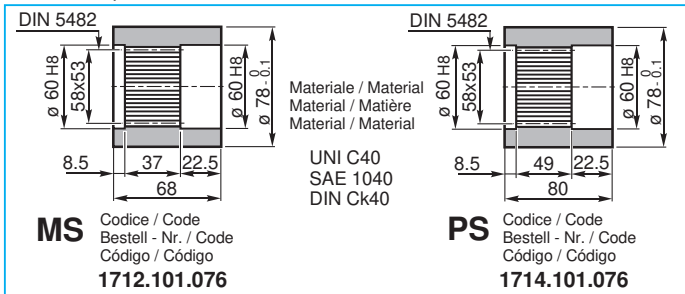

MS Codice / Code
Bestell - Nr. / Code
Código / Código
1712.101.076

PS Codice / Code
Bestell - Nr. / Code
Código / Código
1714.101.076

KB Barra scanalata / Splined rod
Außenverzähnte Welle / Arbre cannelé
Barra ranurada / Barra estriada

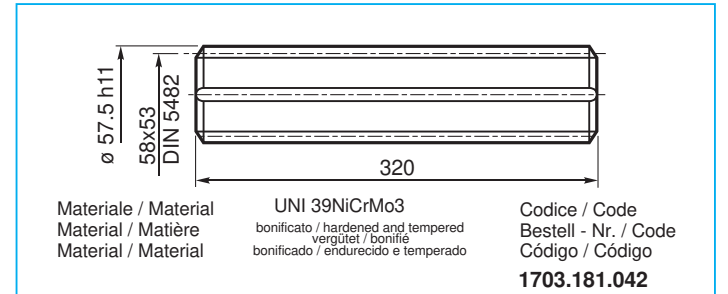

Materiale / Material
Material / Matière
Material / Material

UNI 39NiCrMo3
bonificato / hardened and tempered
vergütet / bonifié
bonificado / endurecido e temperado

Codice / Code
Bestell - Nr. / Code
Código / Código
1703.181.042

FL Flangia / Flange
Flansch / Bride
Brida / Flange

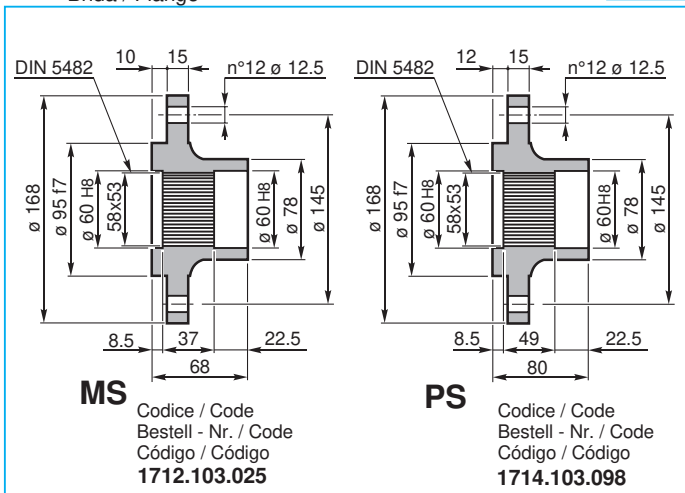

MS Codice / Code
Bestell - Nr. / Code
Código / Código
1712.103.025

PS Codice / Code
Bestell - Nr. / Code
Código / Código
1714.103.098

GA Giunto di attrito / Shrink disc
Schrumpfscheibe / Frette de serrage
Disco de contracción / Disco de contração

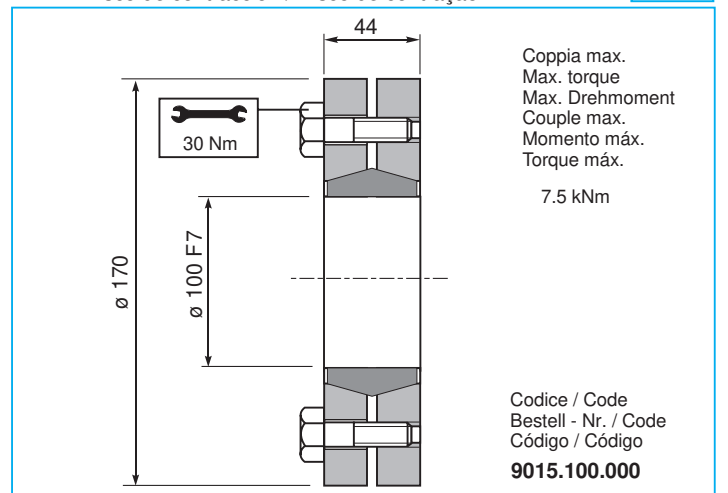

Coppia max.
Max. torque
Max. Drehmoment
Couple max.
Momento máx.
Torque máx.
7.5 kNm

Codice / Code
Bestell - Nr. / Code
Código / Código
9015.100.000

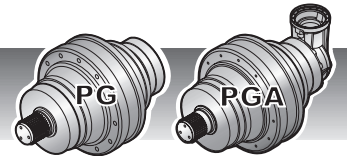

CARICHI RADIALI (Fr)

Nei diagrammi seguenti sono riportati i carichi radiali e i coefficienti K per rapportarli al valore $n_2 \times h$ desiderato.

RADIAL LOADS (Fr)

The following curves show the radial loads and the K factors to obtain the required $n_2 \times h$ value.

RADIALLAST (Fr)

In den nachstehenden Diagrammen ist die Radiallast und der Koeffizient K dargestellt und kann mit dem gewünschten Wert $n_2 \times h$ verglichen werden.

CHARGES RADIALES (Fr)

Dans les diagrammes suivants sont indiqués les charges radiales et les facteurs K de façon à obtenir la valeur $n_2 \times h$ désirée.

CARGAS RADIALES (Fr)

En los siguientes diagramas se indican las cargas radiales y los coeficientes K para obtener el valor requerido $n_2 \times h$.

CARGAS RADIAIS (Fr)

Nos diagramas seguintes são indicadas as cargas radiais e os coeficientes K para obter o valor $n_2 \times h$ desejado.

M - P - CPC*

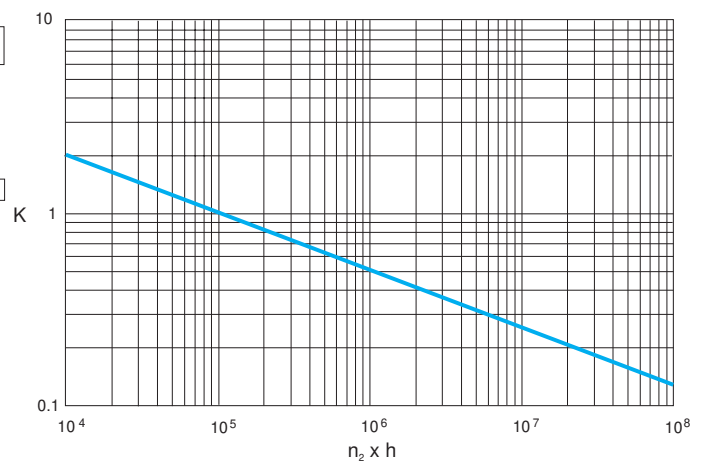
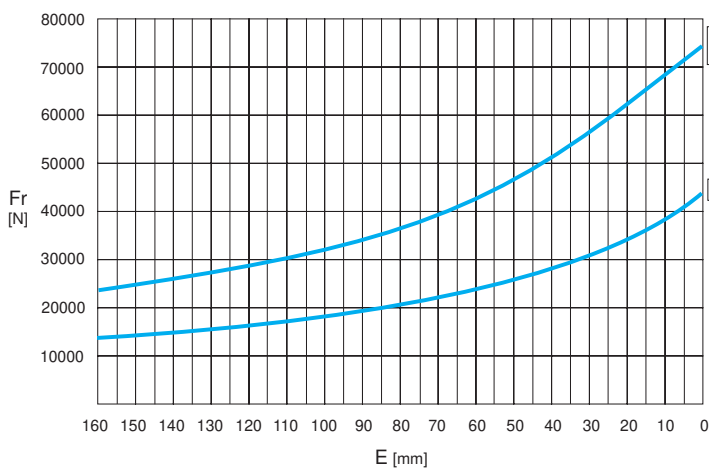

	$n_2 \times h$				
	10^5	10^4	10^6	10^7	10^8
M - P	Fr			Fr · K	
*CPC	Fr · 0.75			Fr · K · 0.75	

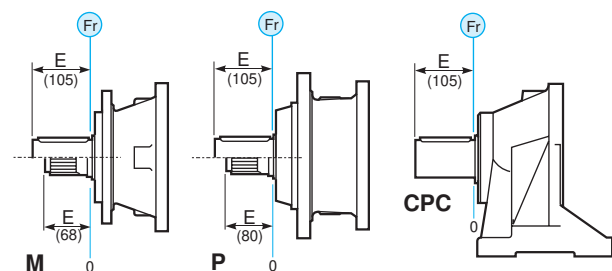

CARICHI ASSIALI (Fa)

I valori dei carichi assiali indicati in tabella sono riferiti alle versioni e alla direzione di applicazione del carico.

AXIAL LOADS (Fa)

The values of the axial loads in the table refer to the output versions and load direction of application.

AXIALLAST (Fa)

Die dargestellten Werte der Axiallast basieren auf der Version und der applizierten Lastrichtung.

CHARGES AXIALES (Fa)

Les valeurs des charges axiales indiquées dans le tableau se réfèrent aux versions et à la direction d'application de la charge.

CARGAS AXIALES (Fa)

Los valores de las cargas axiales indicados en la tabla se refieren a las versiones y a la dirección de aplicación de la carga.

CARGAS AXIAIS (Fa)

Os valores das cargas axiais indicadas na tabela referem-se às versões e à direção de aplicação da carga.

Fa [N]	M	P - CPC	← →
		32000	
	32000	48000	

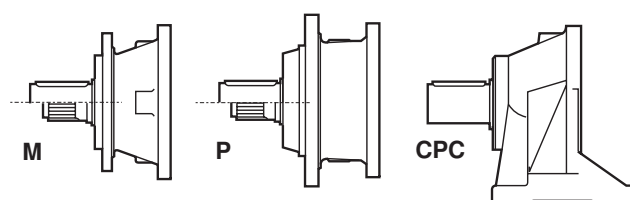



700

IT EN DE FR ES PT

	i	Mc [kNm]				n _{1max} [min ⁻¹]	Pt [kW]	Kg				
		n ₂ x h	n ₂ x h	n ₂ x h	n ₂ x h			M	P	CPC	F	FS
		10.000	20.000	50.000	100.000							
PG 701	3.67	7.93	7.02	5.97	5.29	2800	30	-	67	83	49	70
	4.43	7.24	6.41	5.45	4.83							
	5.00	6.36	5.63	4.79	4.24							
	5.80	5.38	4.76	4.05	3.59							
	7.00	4.35	3.85	3.28	2.90							
PG 702	13.85	7.93	7.02	5.97	5.29	2800	18	-	79	95	61	82
	18.27	7.24	6.41	5.45	4.83							
	20.63	6.36	5.63	4.79	4.24							
	22.88	7.24	6.41	5.45	4.83							
	26.57	7.24	6.41	5.45	4.83							
	30.00	6.36	5.63	4.79	4.24							
	36.25	6.36	5.63	4.79	4.24							
	42.05	5.38	4.76	4.05	3.59							
	50.75	4.35	3.85	3.28	2.90							
PG 703	53.78	7.93	7.02	5.97	5.29	2800	14	-	85	101	67	88
	64.82	7.93	7.02	5.97	5.29							
	71.70	7.24	6.41	5.45	4.83							
	78.29	7.24	6.41	5.45	4.83							
	84.70	7.93	7.02	5.97	5.29							
	93.50	6.51	5.77	4.95	4.37							
	102.09	7.00	6.20	5.32	4.70							
	112.93	7.24	6.41	5.45	4.83							
	127.88	7.93	7.02	5.97	5.29							
	139.22	6.36	5.63	4.79	4.24							
	148.80	7.24	6.41	5.45	4.83							
	154.45	7.24	6.41	5.45	4.83							
	179.36	7.24	6.41	5.45	4.83							
	190.67	6.16	5.43	4.59	4.11							
	216.72	6.44	5.71	4.86	4.29							
	244.69	6.36	5.63	4.79	4.24							
	278.26	6.44	5.71	4.86	4.29							
314.17	6.36	5.63	4.79	4.24								
PG 704	332.44	7.42	6.59	5.60	4.95	2800	8	-	91	107	73	94
	347.96	7.93	7.02	5.97	5.29							
	400.71	7.93	7.02	5.97	5.29							
	434.39	7.42	6.59	5.60	4.95							
	474.32	7.93	7.02	5.97	5.29							
	523.60	6.51	5.77	4.95	4.37							
	571.73	7.93	7.02	5.97	5.29							
	632.40	7.24	6.41	5.45	4.83							
	661.91	7.24	6.41	5.45	4.83							
	747.32	6.36	5.63	4.79	4.24							
	768.67	7.24	6.41	5.45	4.83							
	832.33	7.24	6.41	5.45	4.83							
	884.81	7.00	6.20	5.32	4.70							
	978.71	7.24	6.41	5.45	4.83							
	1042.51	7.24	6.41	5.45	4.83							
	1177.03	6.36	5.63	4.79	4.24							
	1338.54	7.24	6.41	5.45	4.83							
	1651.64	6.36	5.63	4.79	4.24							
	2722.78	6.36	5.63	4.79	4.24							



	i	Mc [kNm]				n _{1max} [min ⁻¹]	Pt [kW]	Kg				
		n ₂ x h	n ₂ x h	n ₂ x h	n ₂ x h			M	P	CPC	F	FS
		10.000	20.000	50.000	100.000							
PGA 702	12.67	6.84	6.23	5.50	5.01	2800	18	-	104	120	86	107
	15.30	7.24	6.41	5.45	4.83							
	17.27	6.36	5.63	4.79	4.24							
	20.04	5.38	4.76	4.05	3.59							
	24.18	4.35	3.85	3.28	2.90							
	27.22	4.37	4.08	3.72	3.47							
	31.58	4.97	4.64	4.05	3.59							
	38.11	4.35	3.85	3.28	2.90							
PGA 703	44.29	7.93	7.02	5.97	5.29	2800	14	-	94	110	76	97
	53.50	7.24	6.41	5.45	4.83							
	55.48	7.93	7.02	5.97	5.29							
	60.40	6.36	5.63	4.79	4.24							
	67.01	7.24	6.41	5.45	4.83							
	77.82	7.24	6.41	5.45	4.83							
	87.86	6.36	5.63	4.79	4.24							
	94.03	6.44	5.71	4.86	4.29							
	106.16	6.36	5.63	4.79	4.24							
	123.15	5.38	4.76	4.05	3.59							
	148.63	4.35	3.85	3.28	2.90							
	PGA 704	157.49	7.93	7.02	5.97							
173.85		7.93	7.02	5.97	5.29							
189.83		7.93	7.02	5.97	5.29							
209.98		7.24	6.41	5.45	4.83							
229.28		7.24	6.41	5.45	4.83							
248.05		7.93	7.02	5.97	5.29							
273.82		6.51	5.77	4.95	4.37							
298.99		7.00	6.20	5.32	4.70							
330.72		7.24	6.41	5.45	4.83							
361.12		7.24	6.41	5.45	4.83							
402.98		6.44	5.71	4.86	4.29							
454.97		6.36	5.63	4.79	4.24							
510.67		6.36	5.63	4.79	4.24							
558.38		6.16	5.43	4.59	4.11							
593.04		6.36	5.63	4.79	4.24							
674.41		7.20	6.35	5.36	4.80							
716.58		6.36	5.63	4.79	4.24							
831.24		5.38	4.76	4.05	3.59							
920.06	6.36	5.63	4.79	4.24								
1067.27	5.38	4.76	4.05	3.59								

700



(n₂ x h = 20.000)

$$M_{\max} = M_c \times 2$$

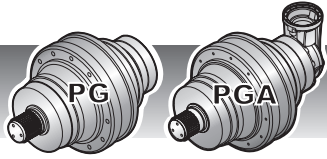

700

IT EN DE FR ES PT

PS

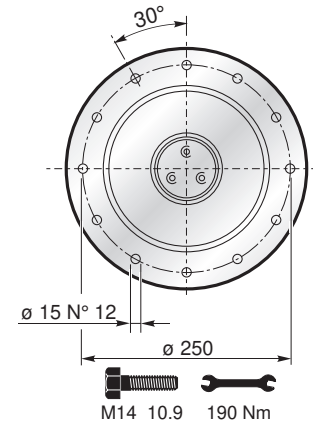
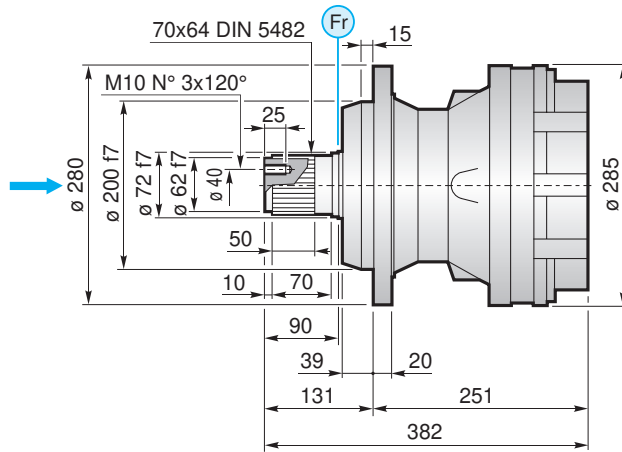
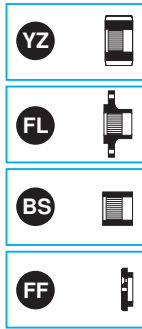

PC

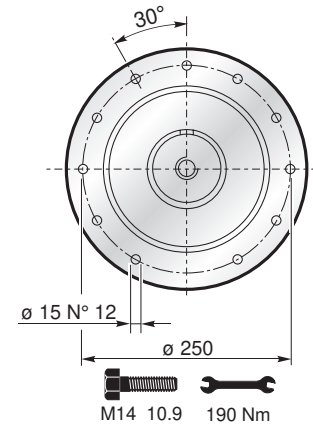
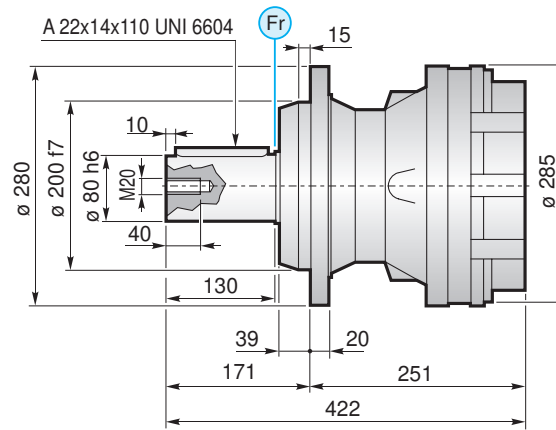

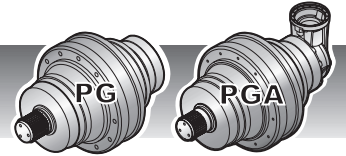

F

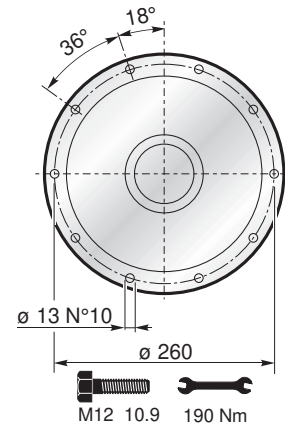
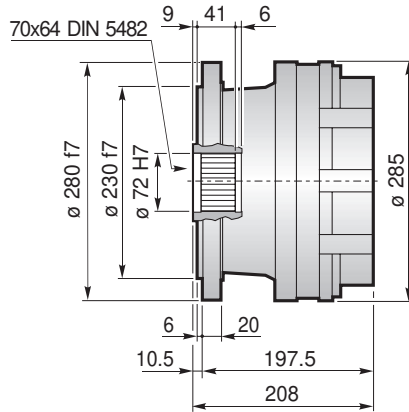
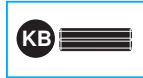

FS

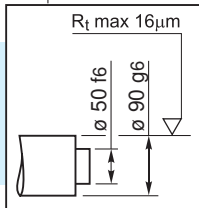
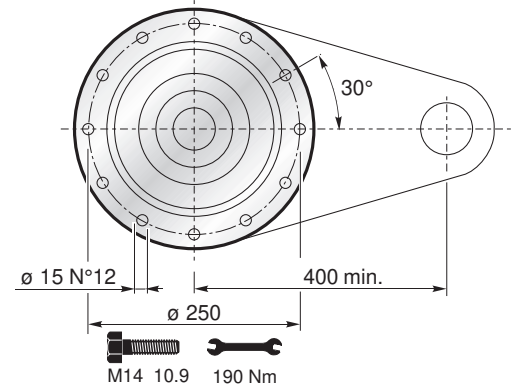
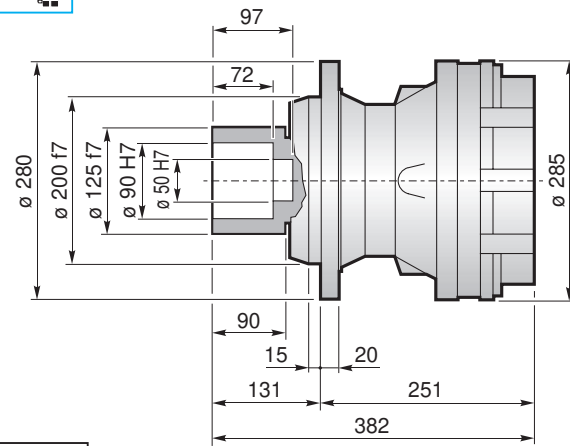

$M_{max} = 13 \text{ kNm}$

La coppia massima indicata è valida solo con calettatori forniti da Planetary Drives
 The maximum torque indicated is valid only with shrink discs supplied by Planetary Drives
 Das dargestellte, maximale Drehmoment gilt nur mit von Planetary Drives gelieferter Schrumpfscheibe
 Le couple maximal indiqué n'est valable qu'avec les frettes de serrage fournis par Planetary Drives
 El momento máximo indicado sólo es válido con discos de contracción suministrados por Planetary Drives
 O torque máximo indicado é válido exclusivamente com discos de contração fornecidos pela Planetary Drives

CPC

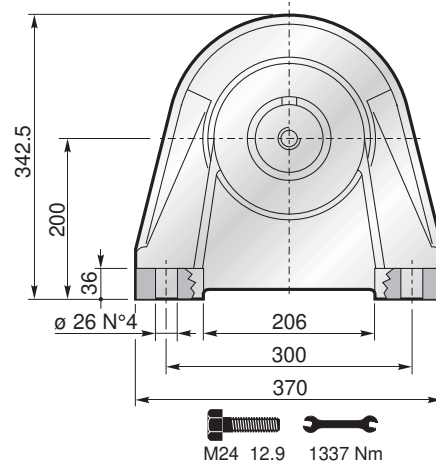
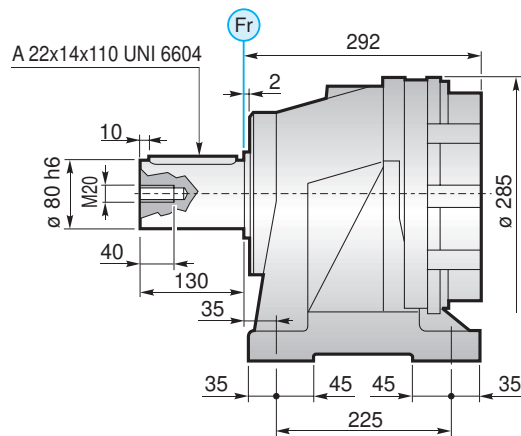

FL YZ BS FF KB GA → B-42



700

IT EN DE FR ES PT

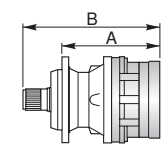
	PG ...PS					
	A	B	RA	RB	EF	EDF
PG 701	251	382		•		
PG 702	310.5	441.5	•	o	•	
PG 703	358.5	489.5	•			•
PG 704	406.5	537.5	•			•

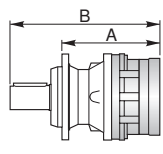
	PG ...PC					
	A	B	RA	RB	EF	EDF
PG 701	251	422		•		
PG 702	310.5	481.5	•	o	•	
PG 703	358.5	529.5	•			•
PG 704	406.5	577.5	•			•

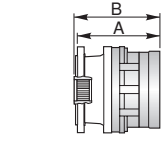
	PG ...F					
	A	B	RA	RB	EF	EDF
PG 701	197.5	208		•		
PG 702	257	285	•	o	•	
PG 703	305	315.5	•			•
PG 704	353	363.5	•			•

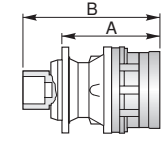
	PG ...FS					
	A	B	RA	RB	EF	EDF
PG 701	251	382		•		
PG 702	310.5	441.5	•	o	•	
PG 703	358.5	489.5	•			•
PG 704	406.5	537.5	•			•

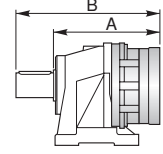
	PG ...CPC					
	A	B	RA	RB	EF	EDF
PG 701	292	422		•		
PG 702	351.5	481.5	•	o	•	
PG 703	399.5	529.5	•			•
PG 704	447.5	577.5	•			•

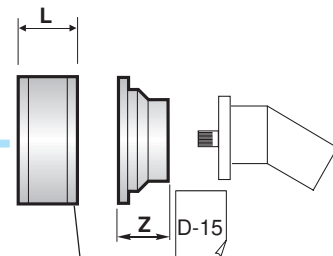
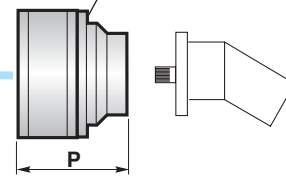
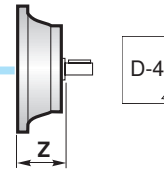
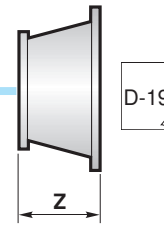
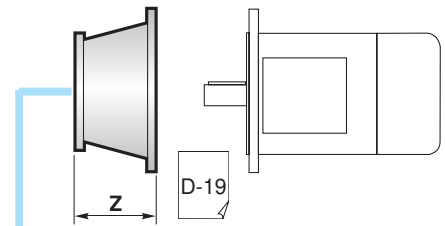

	L
RA	81
RB	125



A+13.5	B+13.5	o
--------	--------	---



PGA ...PS	
	EF
PGA 702	• o •
PGA 703	• • •
PGA 704	• • •

PGA ...PC	
	EF
PGA 702	• o •
PGA 703	• • •
PGA 704	• • •

PGA ...F	
	EF
PGA 702	• o •
PGA 703	• • •
PGA 704	• • •

PGA ...FS	
	EF
PGA 702	• o •
PGA 703	• • •
PGA 704	• • •

PGA ...CPC	
	EF
PGA 702	• o •
PGA 703	• • •
PGA 704	• • •

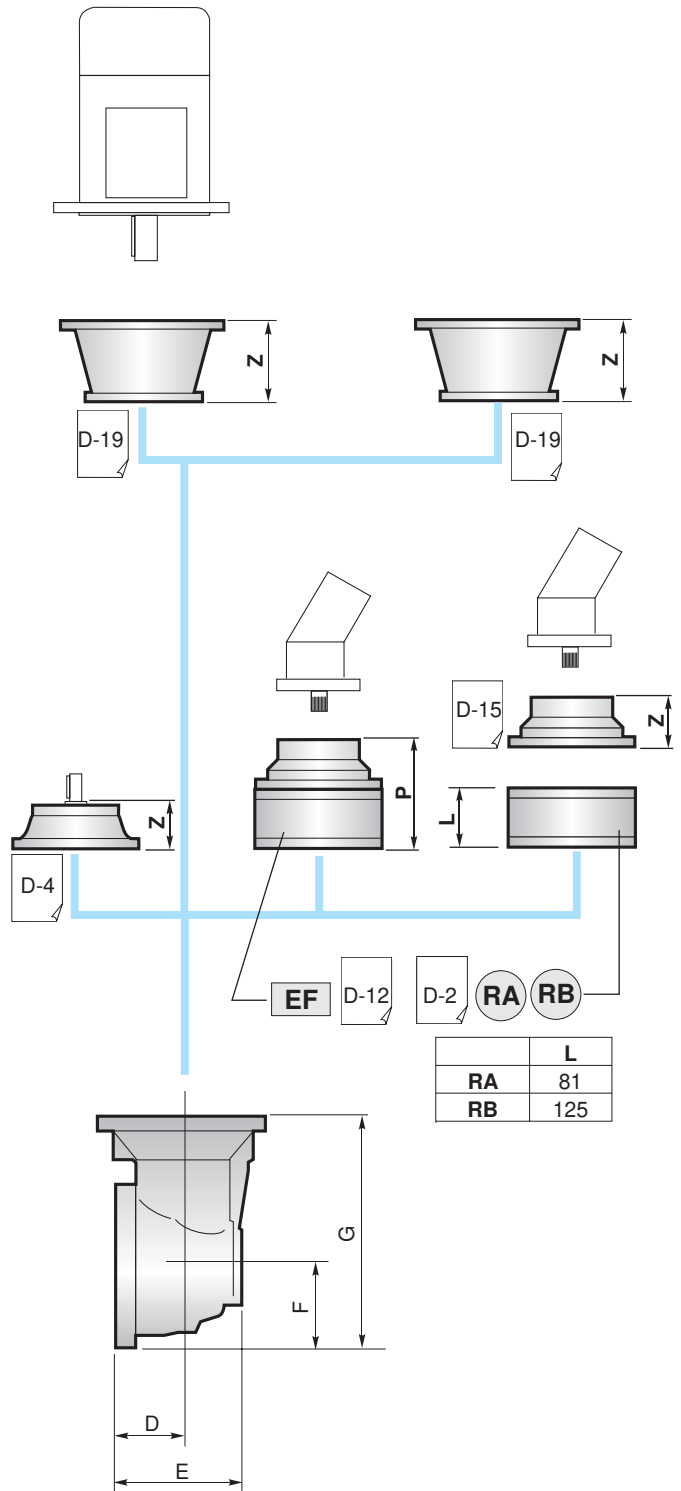

	D	E	F	G
PGA 702	88	164	140	380
PGA 703	75	141.5	93	252
PGA 704	75	141.5	93	252



A	B	•
A	B+16.5	o

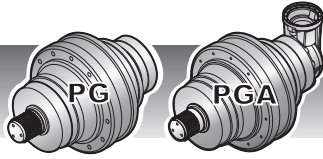

700

IT EN DE FR ES PT

YZ

Pignoni / Pinion
Ritzel / Pignon
Piñones / Pinhões

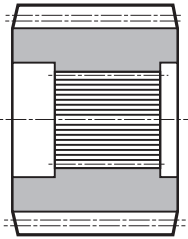

Su richiesta / On request
Auf Anfrage / Sur demande
Bajo demanda / Sob consulta

FF

Fondello di arresto / Stop bottom plate
Endscheibe / Bouchon de fermeture
Tapón de detención / Fundo de batente

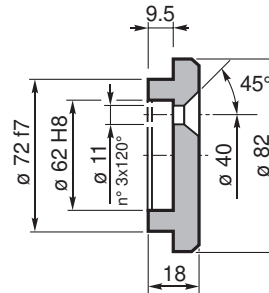

Codice / Code
Bestell - Nr. / Code
Código / Código
5701.012.000

BS

Boccola scanalata / Splined bushing
Innenverzahnte Buchse / Moyeu cannelé
Casquillo ranurado / Bucha estriada

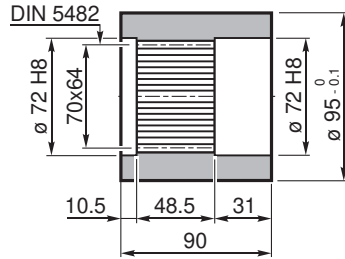

Materiale / Material
Material / Matière
Material / Material
UNI C40
SAE 1040
DIN Ck40

Codice / Code
Bestell - Nr. / Code
Código / Código
1715.102.076

KB

Barra scanalata / Splined rod
Außenverzahnte Welle / Arbre cannelé
Barra ranurada / Barra estriada

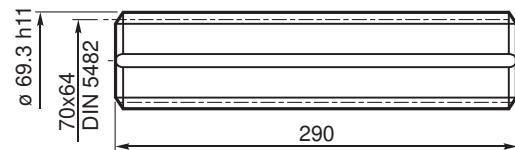

Materiale / Material
Material / Matière
Material / Material
UNI 39NiCrMo3
bonificato / hardened and tempered
vergütet / bonifié
bonificado / endurecido e temperado

Codice / Code
Bestell - Nr. / Code
Código / Código
1703.405.042

FL

Flangia / Flange
Flansch / Bride
Brida / Flange

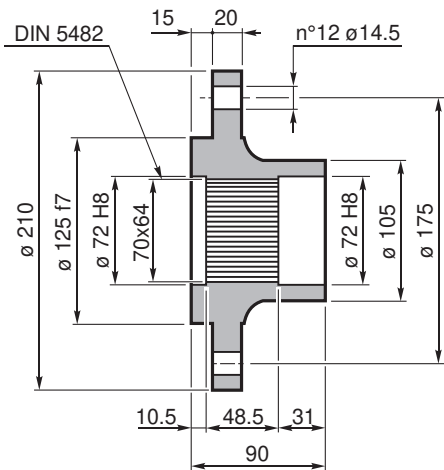

Codice / Code
Bestell - Nr. / Code
Código / Código
1715.108.098

GA

Giunto di attrito / Shrink disc
Schrumpfscheibe / Frette de serrage
Disco de contracción / Disco de contração

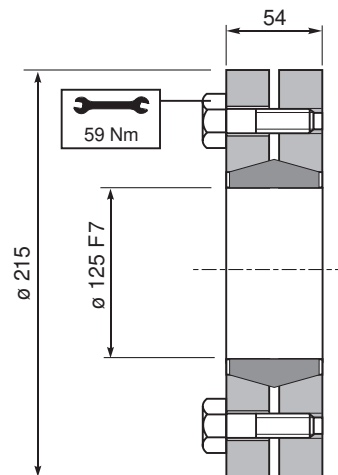

Coppia max.
Max. torque
Max. Drehmoment
Couple max.
Momento máx.
Torque máx.

13 kNm

Codice / Code
Bestell - Nr. / Code
Código / Código
9015.125.000

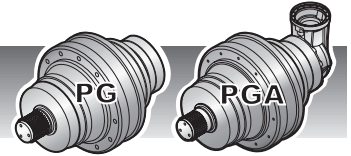

CARICHI RADIALI (Fr)

Nei diagrammi seguenti sono riportati i carichi radiali e i coefficienti K per rapportarli al valore $n_2 \times h$ desiderato.

RADIAL LOADS (Fr)

The following curves show the radial loads and the K factors to obtain the required $n_2 \times h$ value.

RADIALLAST (Fr)

In den nachstehenden Diagrammen ist die Radiallast und der Koeffizient K dargestellt und kann mit dem gewünschten Wert $n_2 \times h$ verglichen werden.

CHARGES RADIALES (Fr)

Dans les diagrammes suivants sont indiqués les charges radiales et les facteurs K de façon à obtenir la valeur $n_2 \times h$ désirée.

CARGAS RADIALES (Fr)

En los siguientes diagramas se indican las cargas radiales y los coeficientes K para obtener el valor requerido $n_2 \times h$.

CARGAS RADIAIS (Fr)

Nos diagramas seguintes são indicadas as cargas radiais e os coeficientes K para obter o valor $n_2 \times h$ desejado.

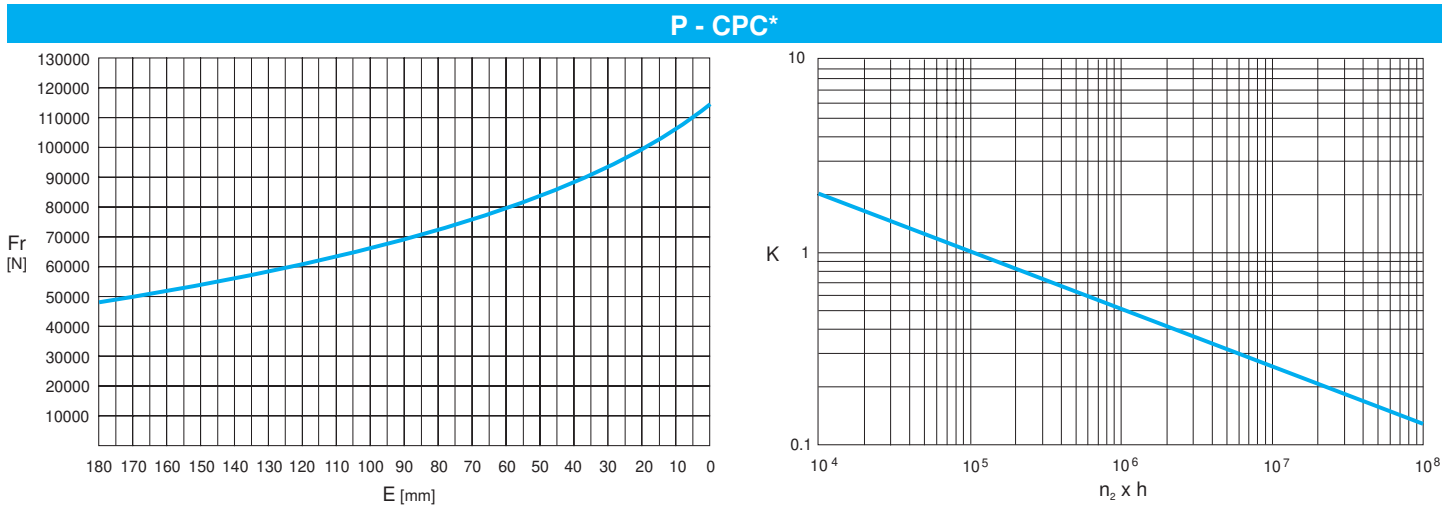

	$n_2 \times h$				
	10^5	10^4	10^6	10^7	10^8
P	Fr		Fr · K		
*CPC	Fr · 0.75		Fr · K · 0.75		

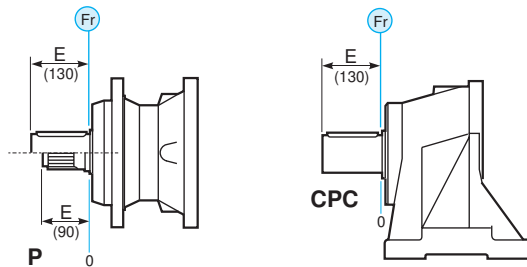

CARICHI ASSIALI (Fa)

I valori dei carichi assiali indicati in tabella sono riferiti alle versioni e alla direzione di applicazione del carico.

AXIAL LOADS (Fa)

The values of the axial loads in the table refer to the output versions and load direction of application.

AXIALLAST (Fa)

Die dargestellten Werte der Axiallast basieren auf der Version und der applizierten Lastrichtung.

CHARGES AXIALES (Fa)

Les valeurs des charges axiales indiquées dans le tableau se réfèrent aux versions et à la direction d'application de la charge.

CARGAS AXIALES (Fa)

Los valores de las cargas axiales indicados en la tabla se refieren a las versiones y a la dirección de aplicación de la carga.

CARGAS AXIAIS (Fa)

Os valores das cargas axiais indicadas na tabela referem-se às versões e à direção de aplicação da carga.

Fa [N]	P	CPC	← →
		40000	
	60000	60000	

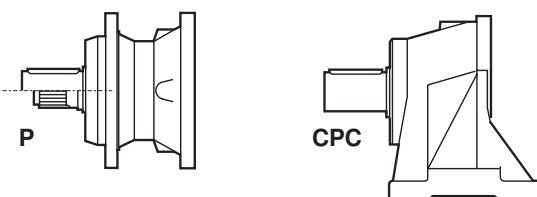



1000

IT EN DE FR ES PT

	i	Mc [kNm]				n _{1max} [min ⁻¹]	Pt [kW]	Kg				
		n ₂ x h	n ₂ x h	n ₂ x h	n ₂ x h			M	P	CPC	F	FS
		10.000	20.000	50.000	100.000							
PG 1001	3.56	13.80	12.21	10.39	9.20	2000	40	97	-	147	65	102
	4.29	11.86	10.50	8.94	7.91							
	5.60	9.22	8.16	6.94	6.15							
	6.75	7.04	6.23	5.30	4.69							
	8.67	4.98	4.41	3.75	3.32							
PG 1002	13.43	13.80	12.21	10.39	9.20	2800	23	113	-	163	81	118
	16.19	11.86	10.50	8.94	7.91							
	18.37	11.87	10.51	8.94	7.92							
	22.14	11.86	10.50	8.94	7.91							
	25.71	11.86	10.50	8.94	7.91							
	28.93	9.22	8.16	6.94	6.15							
	33.60	9.22	8.16	6.94	6.15							
	40.60	9.22	8.16	6.94	6.15							
	48.94	7.04	6.23	5.30	4.69							
PG 1003	57.57	13.80	12.21	10.39	9.20	2800	15	121	-	171	89	126
	62.86	13.80	12.21	10.39	9.20							
	75.77	11.86	10.50	8.94	7.91							
	82.13	11.78	10.41	8.86	7.83							
	94.90	11.86	10.50	8.94	7.91							
	110.20	11.86	10.50	8.94	7.91							
	119.33	11.33	10.03	8.53	7.52							
	124.00	11.70	10.35	8.80	7.76							
	144.00	11.86	10.50	8.94	7.91							
	155.93	9.22	8.16	6.94	6.15							
	173.57	11.86	10.50	8.94	7.91							
	188.16	9.22	8.16	6.94	6.15							
	195.30	9.22	8.16	6.94	6.15							
	209.73	9.50	8.40	7.15	6.34							
	226.80	9.22	8.16	6.94	6.15							
	235.41	7.04	6.23	5.30	4.69							
	274.05	9.22	8.16	6.94	6.15							
	330.33	7.04	6.23	5.30	4.69							
PG 1004	352.00	13.80	12.21	10.39	9.20	2800	11	127	-	177	95	132
	388.57	11.86	10.50	8.94	7.91							
	413.91	11.33	10.00	8.44	7.55							
	440.89	11.87	10.51	8.94	7.92							
	468.37	11.86	10.50	8.94	7.91							
	511.42	11.86	10.50	8.94	7.91							
	531.43	11.86	10.50	8.94	7.91							
	566.08	11.87	10.51	8.94	7.92							
	601.36	11.86	10.50	8.94	7.91							
	640.56	11.86	10.50	8.94	7.91							
	724.42	9.22	8.16	6.94	6.15							
	806.40	10.40	9.22	7.84	6.95							
	907.35	9.22	8.16	6.94	6.15							
	972.00	11.86	10.50	8.94	7.91							
	1074.67	11.86	10.50	8.94	7.91							
	1171.61	11.86	10.50	8.94	7.91							
	1270.08	9.22	8.16	6.94	6.15							
	1530.90	9.22	8.16	6.94	6.15							
	1817.68	9.50	8.40	7.15	6.34							
	2229.71	7.04	6.23	5.30	4.69							



	i	Mc [kNm]				n _{1max} [min ⁻¹]	Pt [kW]	Kg				
		n ₂ x h	n ₂ x h	n ₂ x h	n ₂ x h			M	P	CPC	F	FS
		10.000	20.000	50.000	100.000							
PGA 1002	12.28	6.66	6.07	5.36	4.88	2800	23	134	-	184	102	139
	14.81	7.83	7.13	6.30	5.73							
	19.35	9.22	8.16	6.94	6.15							
	23.32	7.04	6.23	5.30	4.69							
	30.49	4.82	4.50	4.10	3.83							
	36.75	5.67	5.29	4.82	4.50							
PGA 1003	46.40	13.80	12.21	10.39	9.20	2800	15	153	-	203	121	158
	50.67	13.80	12.21	10.39	9.20							
	61.07	11.86	10.50	8.94	7.91							
	73.70	10.40	9.22	7.84	6.95							
	88.83	11.86	10.50	8.94	7.91							
	96.25	11.86	10.50	8.94	7.91							
	116.15	10.40	9.22	7.84	6.95							
	120.56	11.86	10.50	8.94	7.91							
	125.77	9.22	8.16	6.94	6.15							
	140.00	11.86	10.50	8.94	7.91							
	157.53	9.22	8.16	6.94	6.15							
	182.93	9.22	8.16	6.94	6.15							
	221.04	9.22	8.16	6.94	6.15							
	266.44	7.04	6.23	5.30	4.69							
PGA 1004	139.86	13.80	12.21	10.39	9.20	2800	11	136	-	186	104	141
	168.59	11.86	10.50	8.94	7.91							
	184.08	13.80	12.21	10.39	9.20							
	203.21	11.86	10.50	8.94	7.91							
	230.57	11.86	10.50	8.94	7.91							
	267.76	11.86	10.50	8.94	7.91							
	277.92	11.86	10.50	8.94	7.91							
	301.27	9.22	8.16	6.94	6.15							
	322.74	11.86	10.50	8.94	7.91							
	349.87	10.40	9.22	7.84	6.95							
	378.84	9.22	8.16	6.94	6.15							
	421.71	9.22	8.16	6.94	6.15							
	474.51	9.22	8.16	6.94	6.15							
	508.32	11.86	10.50	8.94	7.91							
	551.04	9.22	8.16	6.94	6.15							
	665.84	9.22	8.16	6.94	6.15							
802.58	7.04	6.23	5.30	4.69								
967.39	7.04	6.23	5.30	4.69								

1000



(n₂ x h = 20.000)

$$M_{\max} = M_c \times 2$$

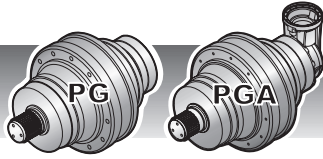

1000

IT EN DE FR ES PT

MS

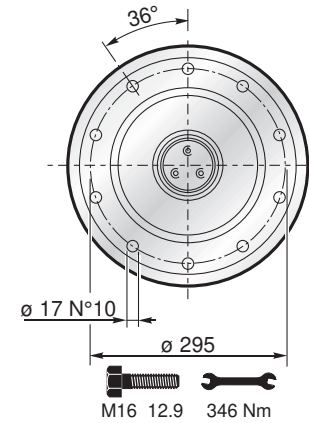
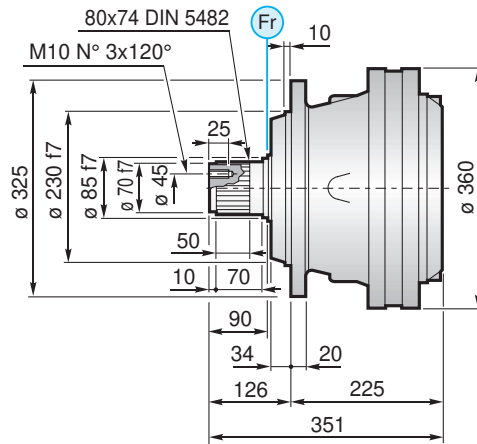
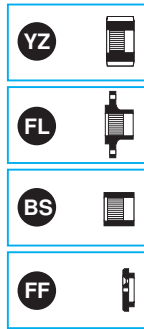

MC

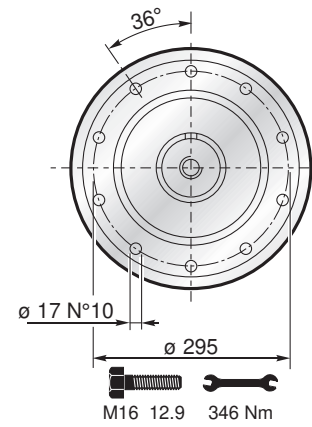
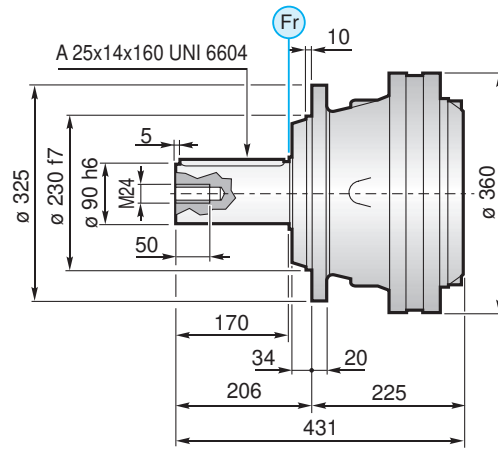



1000

IT EN DE FR ES PT

	PG ...MS					
	A	B	RA	RB	EF	EDF
PG 1001	225	351		•		
PG 1002	296.5	422.5	•	o	•	
PG 1003	357.5	483.5	•			•
PG 1004	405.5	531.5	•			•

	PG ...MC					
	A	B	RA	RB	EF	EDF
PG 1001	225	431		•		
PG 1002	296.5	502.5	•	o	•	
PG 1003	357.5	563.5	•			•
PG 1004	405.5	611.5	•			•

	PG ...F					
	A	B	RA	RB	EF	EDF
PG 1001	112	180		•		
PG 1002	183.5	251.5	•	o	•	
PG 1003	244.5	383.5	•			•
PG 1004	292.5	360.5	•			•

	PG ...FS					
	A	B	RA	RB	EF	EDF
PG 1001	225	361		•		
PG 1002	296.5	432.5	•	o	•	
PG 1003	357.5	493.5	•			•
PG 1004	405.5	541.5	•			•

	PG ...CPC					
	A	B	RA	RB	EF	EDF
PG 1001	272	442		•		
PG 1002	343.5	513.5	•	o	•	
PG 1003	404.5	574.5	•			•
PG 1004	452.5	622.5	•			•

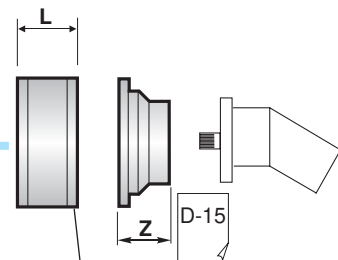
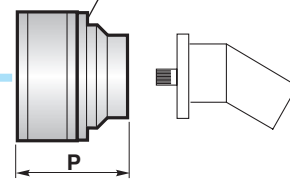
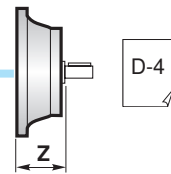
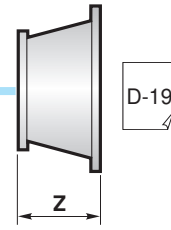
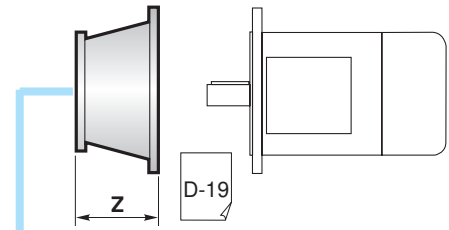

D-2	RA	RB	L
	RA	RB	81
			125

	A+13.5	B+13.5	o
--	--------	--------	---



	PGA ...MS		RA	RB	EF
	A	B			
PGA 1002	313	240	•	o	•
PGA 1003	398	240	•	o	•
PGA 1004	432.5	159	•		•

	PGA ...MC		RA	RB	EF
	A	B			
PGA 1002	313	240	•	o	•
PGA 1003	398	240	•	o	•
PGA 1004	432.5	159	•		•

	PGA ...F		RA	RB	EF
	A	B			
PGA 1002	200	240	•	o	•
PGA 1003	285	240	•	o	•
PGA 1004	319.5	159	•		•

	PGA ...FS		RA	RB	EF
	A	B			
PGA 1002	313	240	•	o	•
PGA 1003	398	240	•	o	•
PGA 1004	432.5	159	•		•

	PGA ...CPC		RA	RB	EF
	A	B			
PGA 1002	360	240	•	o	•
PGA 1003	445	240	•	o	•
PGA 1004	479.5	159	•		•

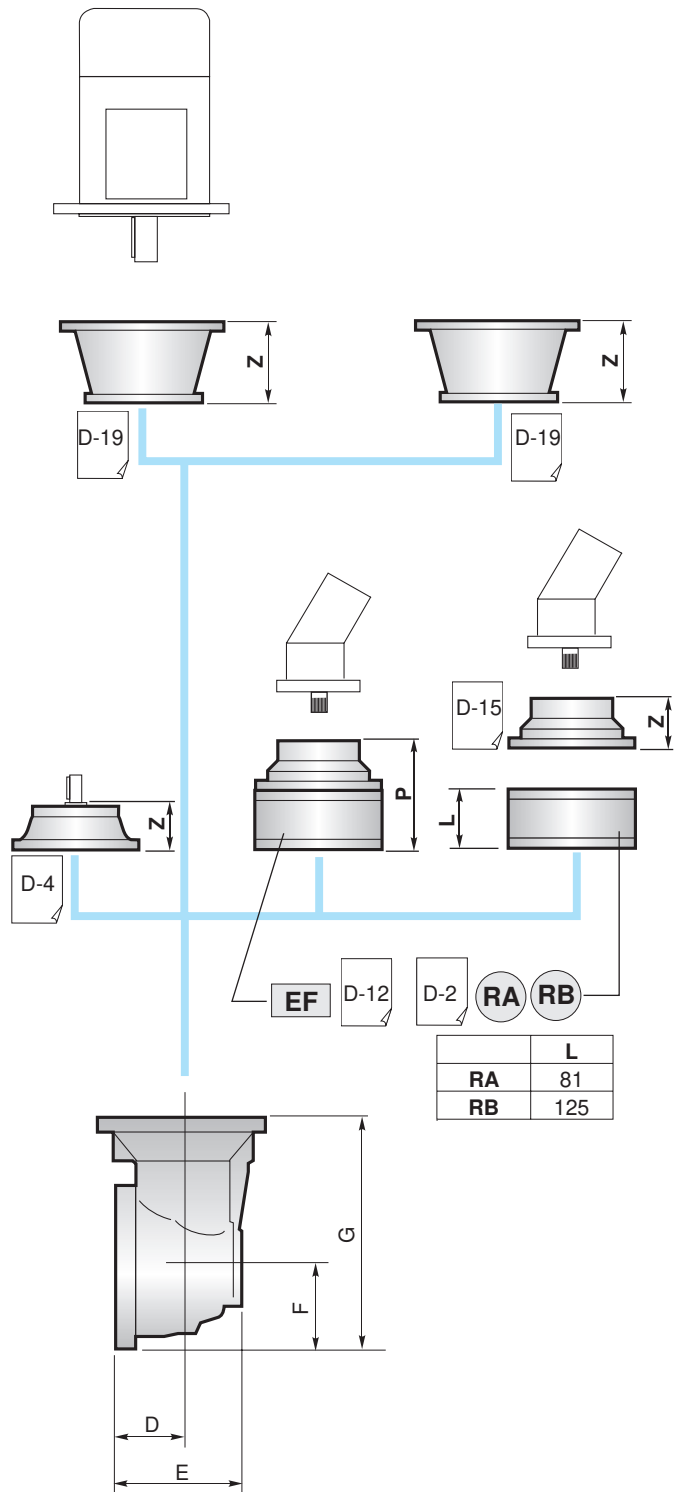

1000

	D	E	F	G
PGA 1002	88	164	140	380
PGA 1003	88	164	140	380
PGA 1004	75	141.5	93	252

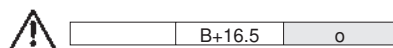

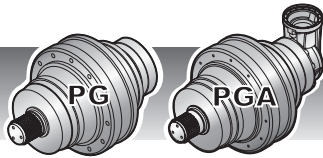

1000

IT EN DE FR ES PT

YZ Pignoni / Pinion
Ritzel / Pignon
Piñones / Pinhões

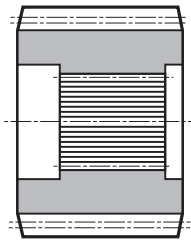

Su richiesta / On request
Auf Anfrage / Sur demande
Bajo demanda / Sob consulta

FF Fondello di arresto / Stop bottom plate
Endscheibe / Bouchon de fermeture
Tapón de detención / Fundo de batente

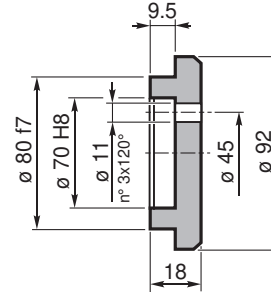

Codice / Code
Bestell - Nr. / Code
Código / Código
5701.030.000

BS Boccola scanalata / Splined bushing
Innenverzähnte Buchse / Moyeu cannelé
Casquillo ranurado / Bucha estriada

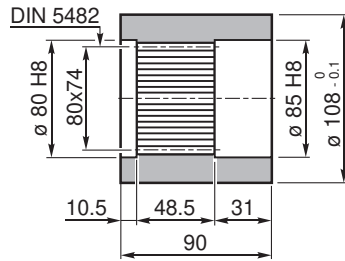

Materiale / Material
Material / Matière
Material / Material
UNI C40
SAE 1040
DIN Ck40

Codice / Code
Bestell - Nr. / Code
Código / Código
1716.103.076

KB Barra scanalata / Splined rod
Außenverzähnte Welle / Arbre cannelé
Barra ranurada / Barra estriada

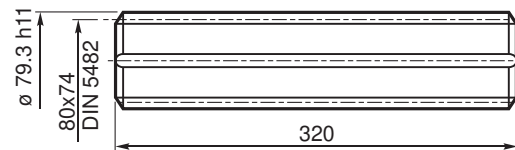

Materiale / Material
Material / Matière
Material / Material

UNI 39NiCrMo3
bonificato / hardened and tempered
vergütet / bonifié
bonificado / endurecido e temperado

Codice / Code
Bestell - Nr. / Code
Código / Código
1703.406.042

FL Flangia / Flange
Flansch / Bride
Brida / Flange

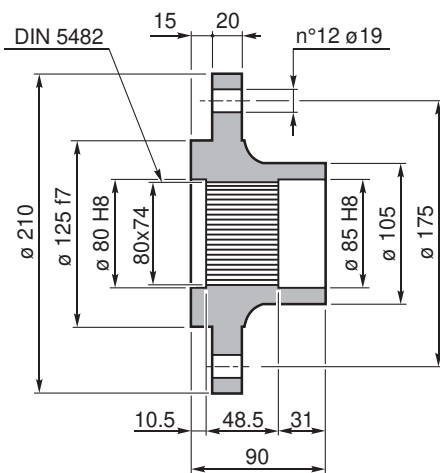

Codice / Code
Bestell - Nr. / Code
Código / Código
1716.105.098

GA Giunto di attrito / Shrink disc
Schrumpfscheibe / Frette de serrage
Disco de contracción / Disco de contração

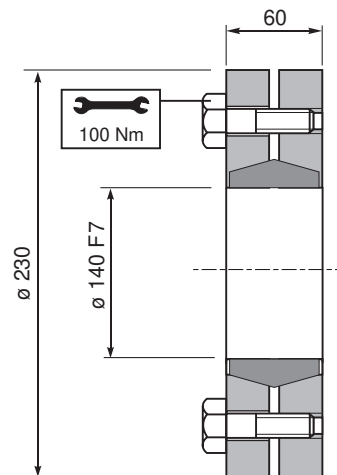

Coppia max.
Max. torque
Max. Drehmoment
Couple max.
Momento máx.
Torque máx.

17,6 kNm

Codice / Code
Bestell - Nr. / Code
Código / Código
9015.140.000

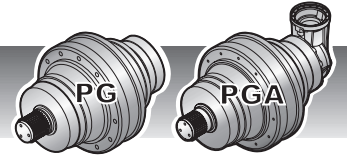

CARICHI RADIALI (Fr)

Nei diagrammi seguenti sono riportati i carichi radiali e i coefficienti K per rapportarli al valore $n_2 \times h$ desiderato.

RADIAL LOADS (Fr)

The following curves show the radial loads and the K factors to obtain the required $n_2 \times h$ value.

RADIALLAST (Fr)

In den nachstehenden Diagrammen ist die Radiallast und der Koeffizient K dargestellt und kann mit dem gewünschten Wert $n_2 \times h$ verglichen werden.

CHARGES RADIALES (Fr)

Dans les diagrammes suivants sont indiqués les charges radiales et les facteurs K de façon à obtenir la valeur $n_2 \times h$ désirée.

CARGAS RADIALES (Fr)

En los siguientes diagramas se indican las cargas radiales y los coeficientes K para obtener el valor requerido $n_2 \times h$.

CARGAS RADIAIS (Fr)

Nos diagramas seguintes são indicadas as cargas radiais e os coeficientes K para obter o valor $n_2 \times h$ desejado.

M - CPC

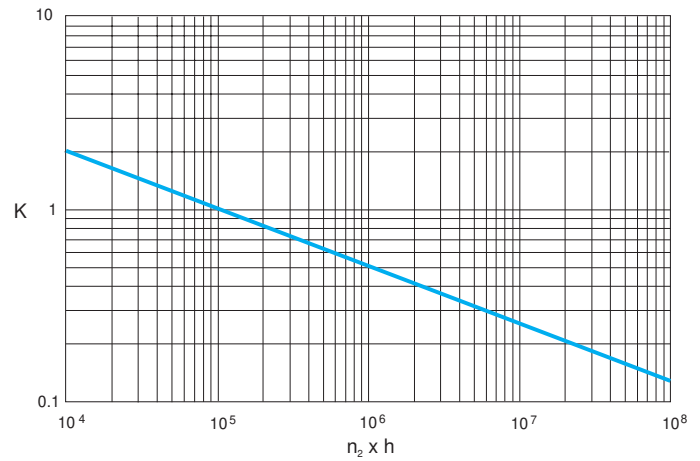
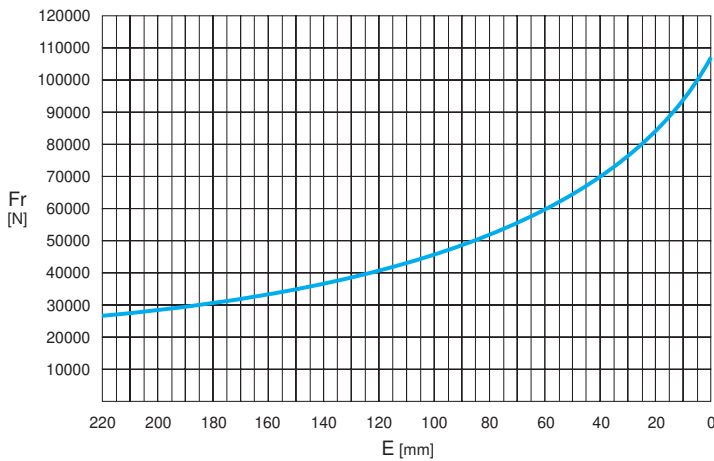

	$n_2 \times h$			
	10^5	10^4	10^6	10^8
M	Fr		Fr • K	
*CPC	Fr • 0.75		Fr • K • 0.75	

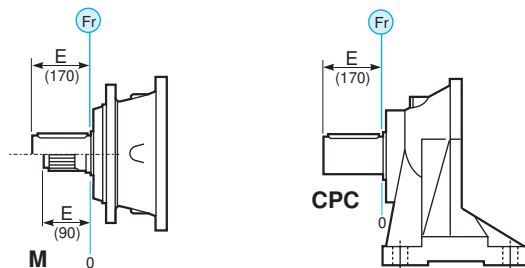

1000

CARICHI ASSIALI (Fa)

I valori dei carichi assiali indicati in tabella sono riferiti alle versioni e alla direzione di applicazione del carico.

AXIAL LOADS (Fa)

The values of the axial loads in the table refer to the output versions and load direction of application.

AXIALLAST (Fa)

Die dargestellten Werte der Axiallast basieren auf der Version und der applizierten Lastichtung.

CHARGES AXIALES (Fa)

Les valeurs des charges axiales indiquées dans le tableau se réfèrent aux versions et à la direction d'application de la charge.

CARGAS AXIALES (Fa)

Los valores de las cargas axiales indicados en la tabla se refieren a las versiones y a la dirección de aplicación de la carga.

CARGAS AXIAIS (Fa)

Os valores das cargas axiais indicadas na tabela referem-se às versões e à direção de aplicação da carga.

Fa [N]	P	CPC	← →
	40000	40000	
60000	60000	60000	

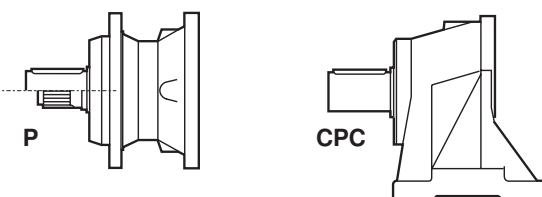



1600

IT EN DE FR ES PT

	i	Mc [kNm]				n _{1max} [min ⁻¹]	Pt [kW]	Kg				
		n ₂ x h	n ₂ x h	n ₂ x h	n ₂ x h			M	P	CPC	F	FS
		10.000	20.000	50.000	100.000							
PG 1601	3.56	20.36	18.02	15.33	13.57	2000	40	105	132	155	74	110
	4.29	17.74	15.70	13.36	11.83							
	5.60	13.57	12.01	10.22	9.05							
	6.75	10.32	9.13	7.77	6.88							
PG 1602	13.43	15.92	14.10	12.01	10.63	2800	23	121	148	171	90	126
	16.19	17.74	15.70	13.36	11.83							
	22.14	13.84	12.26	10.43	9.24							
	28.93	13.57	12.01	10.22	9.05							
	33.60	13.57	12.01	10.22	9.05							
	40.60	11.84	10.47	8.91	7.91							
	48.94	10.32	9.13	7.77	6.88							
PG 1603	57.57	17.74	15.70	13.36	11.83	2800	15	129	156	179	98	134
	62.86	16.93	15.00	12.78	11.30							
	75.77	16.93	15.00	12.78	11.30							
	82.13	13.57	12.01	10.22	9.05							
	94.90	13.84	12.26	10.43	9.24							
	110.20	12.14	10.75	9.14	8.11							
	118.47	13.57	12.01	10.22	9.05							
	124.00	13.84	12.26	10.43	9.24							
	129.36	13.57	12.01	10.22	9.05							
	144.00	13.57	12.01	10.22	9.05							
	155.93	13.57	12.01	10.22	9.05							
	188.16	13.57	12.01	10.22	9.05							
	195.30	13.57	12.01	10.22	9.05							
	226.80	13.57	12.01	10.22	9.05							
	274.05	11.84	10.47	8.91	7.91							
330.33	10.32	9.13	7.77	6.88								
PG 1604	352.00	16.93	15.00	12.78	11.30	2800	11	135	162	185	104	140
	388.57	17.74	15.70	13.36	11.83							
	424.29	16.93	15.00	12.78	11.30							
	440.89	13.84	12.26	10.43	9.24							
	468.37	17.74	15.70	13.36	11.83							
	511.42	16.93	15.00	12.78	11.30							
	531.43	13.84	12.26	10.43	9.24							
	554.40	13.57	12.01	10.22	9.05							
	601.36	15.42	13.61	11.49	10.28							
	656.63	16.58	14.63	12.36	11.06							
	724.42	13.57	12.01	10.22	9.05							
	806.40	13.57	12.01	10.22	9.05							
	907.35	13.57	12.01	10.22	9.05							
	1026.75	13.57	12.01	10.22	9.05							
	1121.12	13.57	12.01	10.22	9.05							
	1270.08	13.57	12.01	10.22	9.05							
	1530.90	13.57	12.01	10.22	9.05							
	1692.60	13.57	12.01	10.22	9.05							
	1965.60	13.57	12.01	10.22	9.05							
	2229.71	10.32	9.13	7.77	6.88							



	i	Mc [kNm]				n _{1max} [min ⁻¹]	Pt [kW]	Kg				
		n ₂ x h	n ₂ x h	n ₂ x h	n ₂ x h			M	P	CPC	F	FS
		10.000	20.000	50.000	100.000							
PGA 1602	10.92	20.36	18.02	15.33	13.57	2000	25	197	224	247	166	202
	13.16	17.74	15.70	13.36	11.83							
	16.59	15.89	14.95	13.80	12.71							
	20.00	17.74	15.70	13.36	11.83							
	26.13	13.57	12.01	10.22	9.05							
PGA 1603	46.40	15.92	14.10	12.01	10.63	2800	15	161	188	211	130	166
	50.67	14.52	12.86	10.96	9.69							
	55.93	17.74	15.70	13.36	11.83							
	61.07	16.93	15.00	12.78	11.30							
	76.49	13.84	12.26	10.43	9.24							
	88.83	12.14	10.75	9.14	8.11							
	99.95	13.57	12.01	10.22	9.05							
	116.07	13.57	12.01	10.22	9.05							
	120.56	13.84	12.26	10.43	9.24							
	125.77	13.57	12.01	10.22	9.05							
	140.00	12.14	10.75	9.14	8.11							
	157.53	13.57	12.01	10.22	9.05							
	182.93	13.57	12.01	10.22	9.05							
	221.04	11.84	10.47	8.91	7.91							
	266.44	10.32	9.13	7.77	6.88							
PGA 1604	139.86	15.36	13.60	11.60	10.24	2800	11	144	171	194	113	149
	168.59	17.74	15.70	13.36	11.83							
	184.08	16.93	15.00	12.78	11.30							
	203.21	17.74	15.70	13.36	11.83							
	221.88	16.93	15.00	12.78	11.30							
	240.53	13.57	12.01	10.22	9.05							
	277.92	13.84	12.26	10.43	9.24							
	301.27	13.57	12.01	10.22	9.05							
	322.74	12.14	10.75	9.14	8.11							
	346.95	13.57	12.01	10.22	9.05							
	378.84	13.57	12.01	10.22	9.05							
	421.71	13.57	12.01	10.22	9.05							
	474.51	13.57	12.01	10.22	9.05							
	508.32	12.14	10.75	9.14	8.11							
	551.04	13.57	12.01	10.22	9.05							
665.84	11.84	10.47	8.91	7.91								
802.58	10.32	9.13	7.77	6.88								
967.39	10.32	9.13	7.77	6.88								

1600

(n₂ x h = 20.000)
 $M_{max} = M_c \times 2$

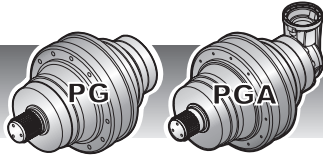

1600

IT EN DE FR ES PT

MS

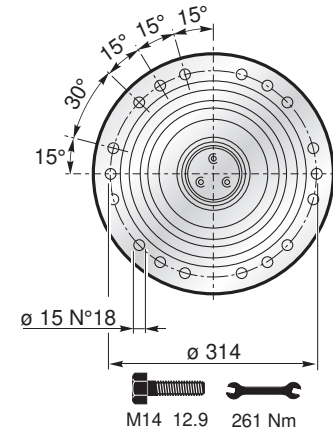
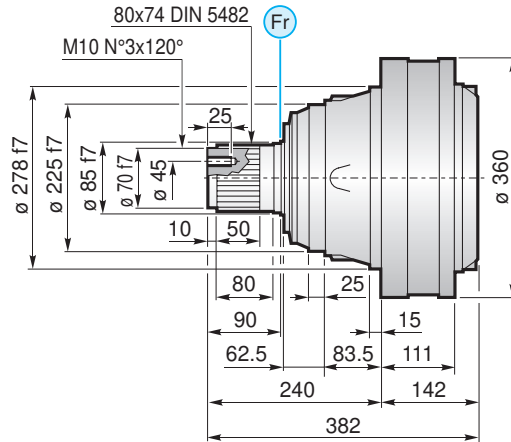
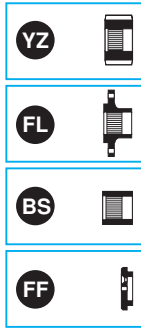

MC

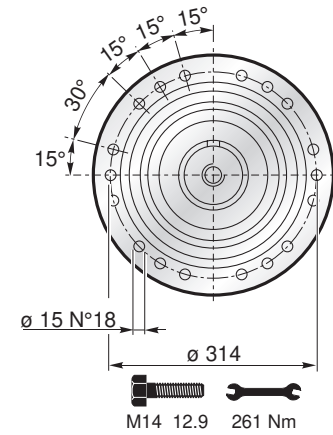
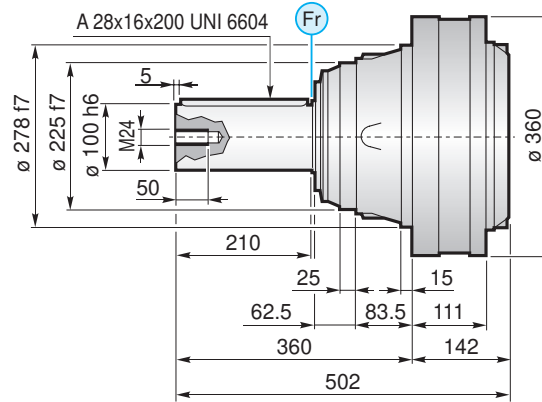

PS

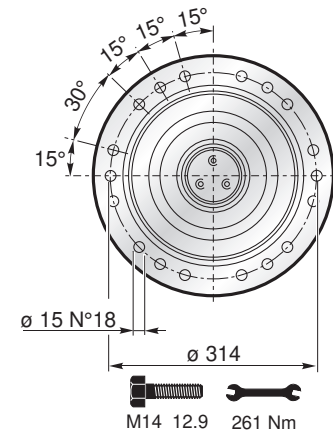
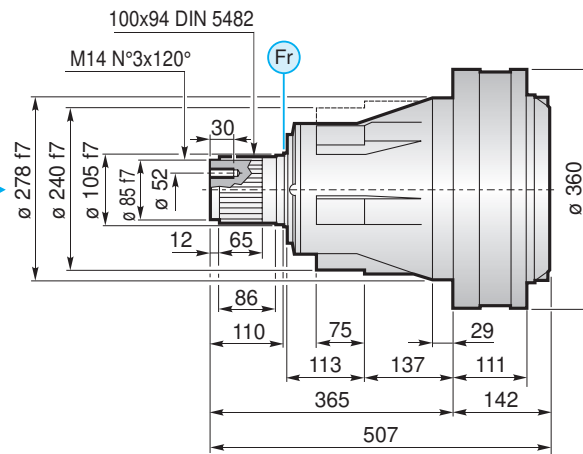
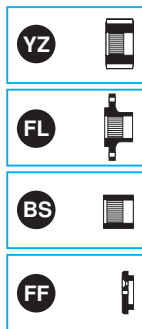

PC

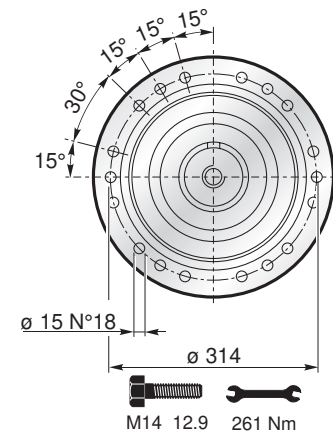
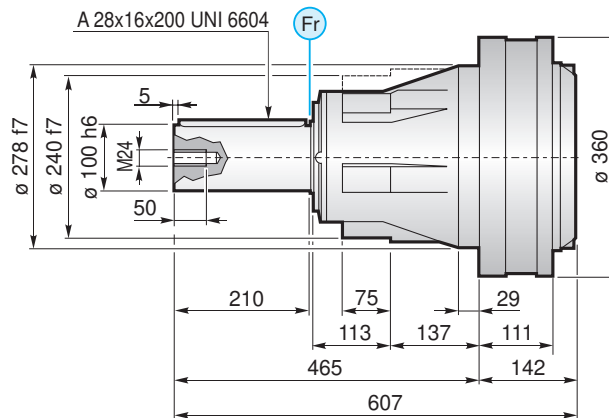



1600

IT EN DE FR ES PT

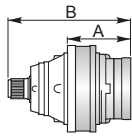
	PG ...MS					
	A	B	RA	RB	EF	EDF
PG1601	142	382		•		
PG1602	213.5	453.5	•	o	•	
PG1603	274.5	514.5	•			•
PG1604	322.5	562.5	•			•

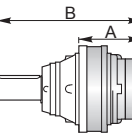
	PG ...MC					
	A	B	RA	RB	EF	EDF
PG1601	142	502			•	
PG1602	213.5	573.5	•	o	•	
PG1603	274.5	634.5	•			•
PG1604	322.5	682.5	•			•

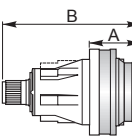
	PG ...PS					
	A	B	RA	RB	EF	EDF
PG1601	142	507			•	
PG1602	213.5	578.5	•	o	•	
PG1603	274.5	639.5	•			•
PG1604	322.5	687.5	•			•

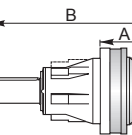
	PG ...PC					
	A	B	RA	RB	EF	EDF
PG1601	142	607			•	
PG1602	213.5	678.5	•	o	•	
PG1603	274.5	739.5	•			•
PG1604	322.5	787.5	•			•

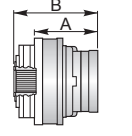
	PG ...F					
	A	B	RA	RB	EF	EDF
PG1601	132	200			•	
PG1602	203.5	271.5	•	o	•	
PG1603	264.5	332.5	•			•
PG1604	312.5	380.5	•			•

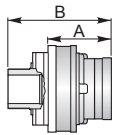
	PG ...FS					
	A	B	RA	RB	EF	EDF
PG1601	142	393			•	
PG1602	213.5	464.5	•	o	•	
PG1603	274.5	525.5	•			•
PG1604	322.5	573.5	•			•

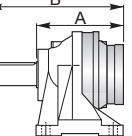
	PG ...CPC					
	A	B	RA	RB	EF	EDF
PG1601	296	506			•	
PG1602	317.5	577.5	•	o	•	
PG1603	428.5	638.5	•			•
PG1604	476.5	686.5	•			•



A	B	•
A+13.5	B+13.5	o

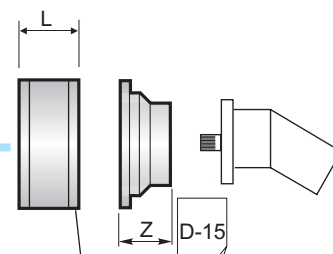
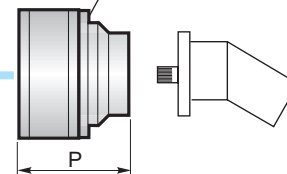
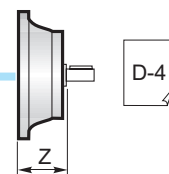
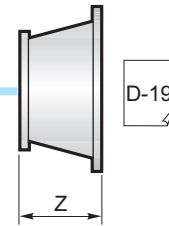
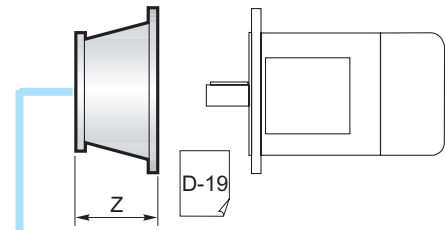

	L
RA	81
RB	125



	PGA ...MS				
	A	B	RA	RB	EF
PGA 1602	230	240	•	o	•
PGA 1603	315	240	•	o	•
PGA 1604	349.5	159	•		•

	PGA ...MC				
	A	B	RA	RB	EF
PGA 1602	230	240	•	o	•
PGA 1603	315	240	•	o	•
PGA 1604	349.5	159	•		•

	PGA ...PS				
	A	B	RA	RB	EF
PGA 1602	230	240	•	o	•
PGA 1603	315	240	•	o	•
PGA 1604	349.5	159	•		•

	PGA ...PC				
	A	B	RA	RB	EF
PGA 1602	230	240	•	o	•
PGA 1603	315	240	•	o	•
PGA 1604	349.5	159	•		•

	PGA ...F				
	A	B	RA	RB	EF
PGA 1602	220	240	•	o	•
PGA 1603	305	240	•	o	•
PGA 1604	339.5	159	•		•

	PGA ...FS				
	A	B	RA	RB	EF
PGA 1602	230	240	•	o	•
PGA 1603	315	240	•	o	•
PGA 1604	349.5	159	•		•

	PGA ...CPC				
	A	B	RA	RB	EF
PGA 1602	384	240	•	o	•
PGA 1603	469	240	•	o	•
PGA 1604	503.5	159	•		•

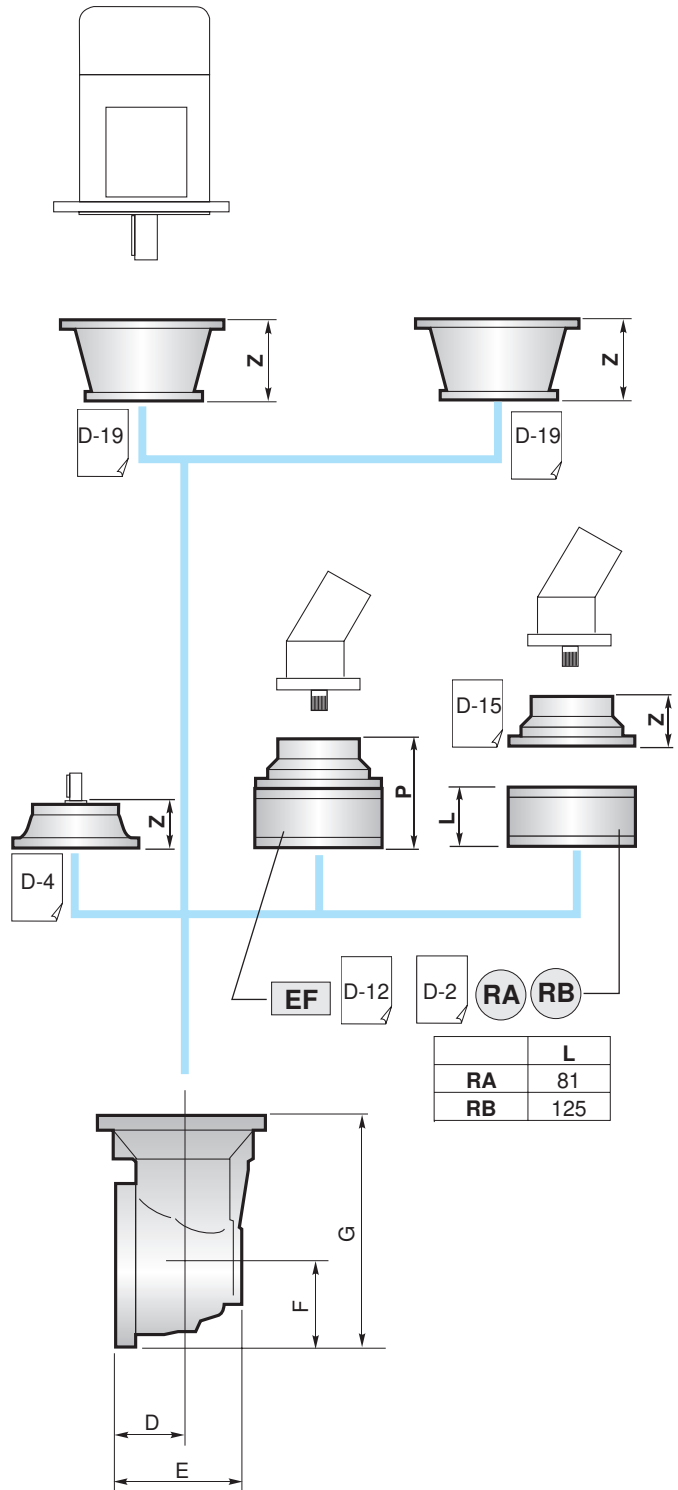

	D	E	F	G
PGA 1602	88	256	235	550
PGA 1603	88	164	140	380
PGA 1604	75	141.5	93	252

B+16.5 o

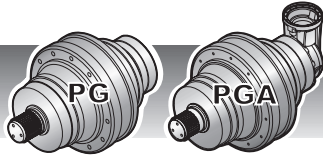

1600

IT EN DE FR ES PT

YZ Pignoni / Pinion
Ritzel / Pignon
Piñones / Pinhões

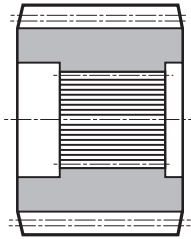

Su richiesta / On request
Auf Anfrage / Sur demande
Bajo demanda / Sob consulta

FF Fondello di arresto / Stop bottom plate
Endscheibe / Bouchon de fermeture
Tapón de detención / Fundo de batente

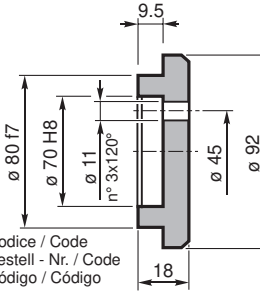

Codice / Code
Bestell - Nr. / Code
Código / Código
5701.030.000

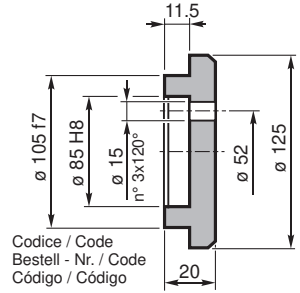

Codice / Code
Bestell - Nr. / Code
Código / Código
5701.042.000

BS Boccola scanalata / Splined bushing
Innenverzähnte Buchse / Moyeu cannelé
Casquillo ranurado / Bucha estriada

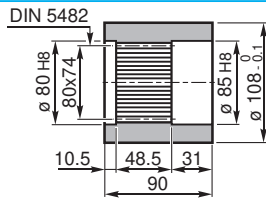

MS Codice / Code
Bestell - Nr. / Code
Código / Código
1716.103.076

Materiale / Material
Material / Matière
Material / Material
UNI C40
SAE 1040
DIN Ck40

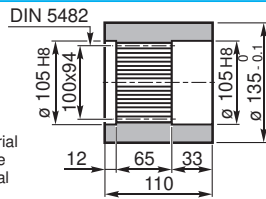

PS Codice / Code
Bestell - Nr. / Code
Código / Código
1718.112.041

KB Barra scanalata / Splined rod
Außenverzähnte Welle / Arbre cannelé
Barra ranurada / Barra estriada

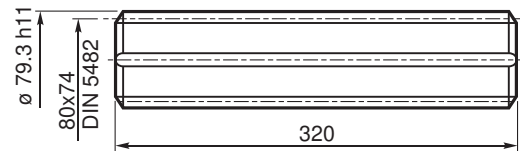

Materiale / Material
Material / Matière
Material / Material

UNI 39NiCrMo3
bonificato / hardened and tempered
vergütet / bonifié
bonificado / endurecido e temperado

Codice / Code
Bestell - Nr. / Code
Código / Código
1703.406.042

FL Flangia / Flange
Flansch / Bride
Brida / Flange

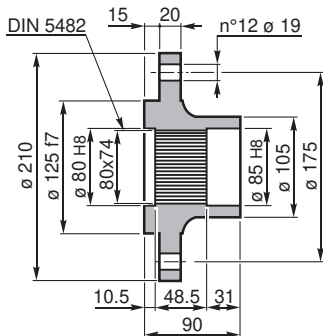

MS Codice / Code
Bestell - Nr. / Code
Código / Código
1716.105.098

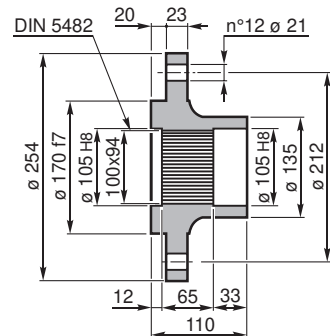

PS Codice / Code
Bestell - Nr. / Code
Código / Código
1718.104.098

GA Giunto di attrito / Shrink disc
Schrumpfscheibe / Frette de serrage
Disco de contracción / Disco de contração

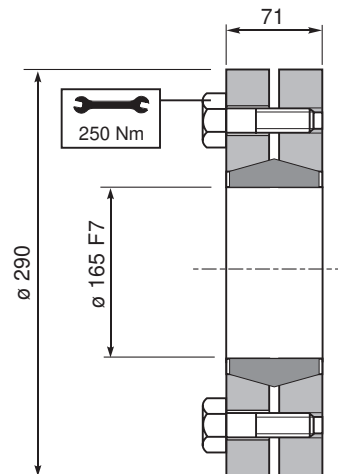

Coppia max.
Max. torque
Max. Drehmoment
Couple max.
Momento máx.
Torque máx.

35 kNm

Codice / Code
Bestell - Nr. / Code
Código / Código
9015.165.000

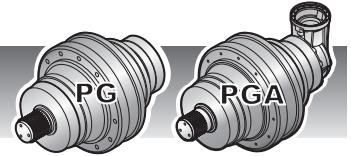

CARICHI RADIALI (Fr)

Nei diagrammi seguenti sono riportati i carichi radiali e i coefficienti K per rapportarli al valore $n_2 \times h$ desiderato.

RADIAL LOADS (Fr)

The following curves show the radial loads and the K factors to obtain the required $n_2 \times h$ value.

RADIALLAST (Fr)

In den nachstehenden Diagrammen ist die Radiallast und der Koeffizient K dargestellt und kann mit dem gewünschten Wert $n_2 \times h$ verglichen werden.

CHARGES RADIALES (Fr)

Dans les diagrammes suivants sont indiqués les charges radiales et les facteurs K de façon à obtenir la valeur $n_2 \times h$ désirée.

CARGAS RADIALES (Fr)

En los siguientes diagramas se indican las cargas radiales y los coeficientes K para obtener el valor requerido $n_2 \times h$.

CARGAS RADIAIS (Fr)

Nos diagramas seguintes são indicadas as cargas radiais e os coeficientes K para obter o valor $n_2 \times h$ desejado.

M - CPC* - P

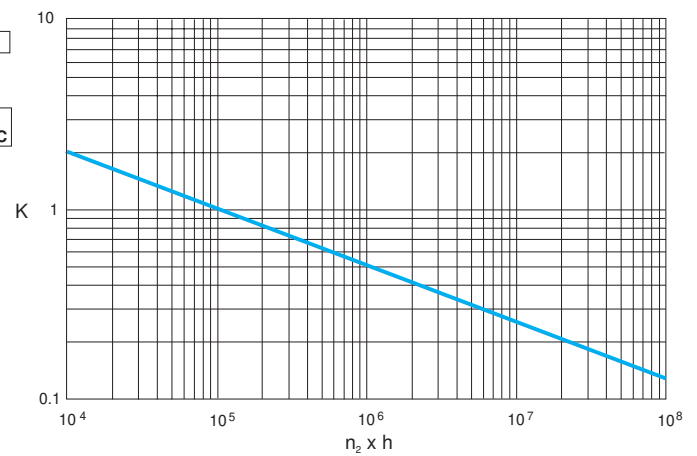
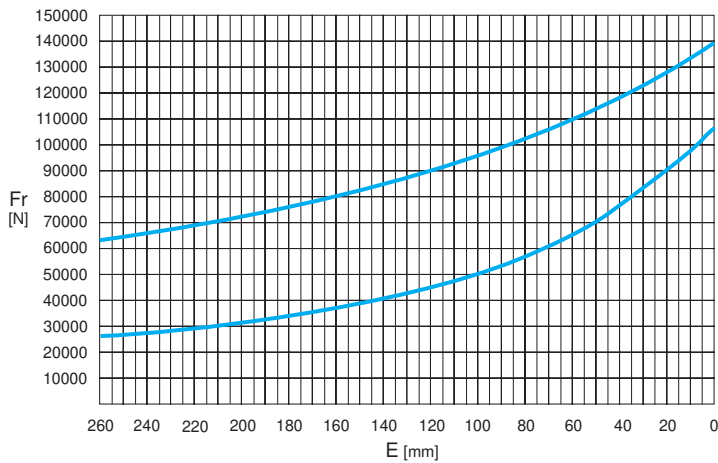

	$n_2 \times h$			
	10^5	10^4	10^6	10^7
M - P	Fr		Fr • K	
*CPC	Fr • 0.75		Fr • K • 0.75	

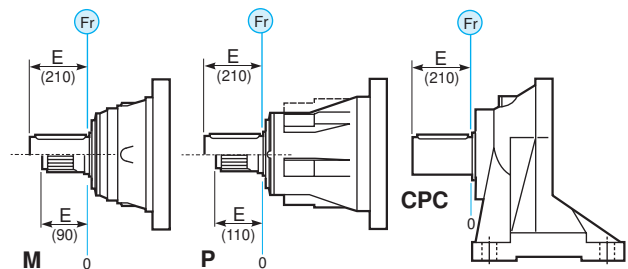

CARICHI ASSIALI (Fa)

I valori dei carichi assiali indicati in tabella sono riferiti alle versioni e alla direzione di applicazione del carico.

AXIAL LOADS (Fa)

The values of the axial loads in the table refer to the output versions and load direction of application.

AXIALLAST (Fa)

Die dargestellten Werte der Axiallast basieren auf der Version und der applizierten Lastrichtung.

CHARGES AXIALES (Fa)

Les valeurs des charges axiales indiquées dans le tableau se réfèrent aux versions et à la direction d'application de la charge.

CARGAS AXIALES (Fa)

Los valores de las cargas axiales indicados en la tabla se refieren a las versiones y a la dirección de aplicación de la carga.

CARGAS AXIAIS (Fa)

Os valores das cargas axiais indicadas na tabela referem-se às versões e à direção de aplicação da carga.

Fa [N]	M - CPC	P	← →
	45000	85000	
65000	85000		

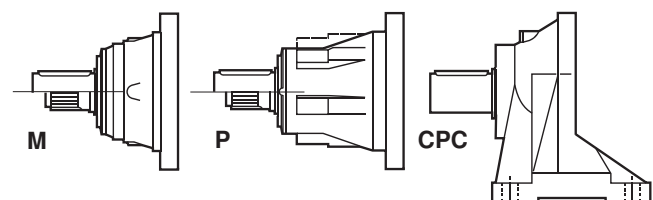



1800

IT EN DE FR ES PT

	i	Mc [kNm]				n _{1max} [min ⁻¹]	Pt [kW]	Kg				
		n ₂ x h	n ₂ x h	n ₂ x h	n ₂ x h			M	P	CPC	F	FS
		10.000	20.000	50.000	100.000							
PG 1802	13.04	20.36	18.02	15.33	13.57	2800	25	130	157	180	99	135
	15.75	19.98	17.69	15.04	13.33							
	18.98	17.74	15.70	13.36	11.83							
	21.43	17.74	15.70	13.36	11.83							
	24.86	17.32	15.32	13.04	11.55							
	30.00	14.00	12.39	10.56	9.33							
	39.20	13.57	12.01	10.22	9.05							
PG 1803	53.78	20.36	18.02	15.33	13.57	2800	17	142	169	192	111	147
	64.95	19.98	17.69	15.04	13.33							
	73.33	17.55	15.54	13.22	11.70							
	81.35	19.98	17.69	15.04	13.33							
	94.48	19.98	17.69	15.04	13.33							
	106.67	17.55	15.54	13.22	11.70							
	128.43	17.32	15.32	13.04	11.55							
	149.14	17.32	15.32	13.04	11.55							
	180.21	17.32	15.32	13.04	11.55							
	217.50	14.00	12.39	10.56	9.33							
PG 1804	275.81	20.36	18.02	15.33	13.57	2800	13	149	176	199	118	154
	332.44	18.00	15.95	13.67	12.08							
	348.66	19.98	17.69	15.04	13.33							
	377.20	20.36	18.02	15.33	13.57							
	438.43	19.98	17.69	15.04	13.33							
	489.25	17.75	15.75	13.38	11.84							
	549.14	19.98	17.69	15.04	13.33							
	620.00	17.55	15.54	13.22	11.70							
	665.82	17.74	15.70	13.36	11.83							
	720.00	17.74	15.70	13.36	11.83							
	770.57	17.75	15.75	13.38	11.84							
	818.79	19.90	17.56	14.83	13.27							
	849.86	17.74	15.70	13.36	11.83							
	928.81	17.74	15.70	13.36	11.83							
	989.38	17.75	15.75	13.38	11.84							
	1114.29	17.74	15.70	13.36	11.83							
	1216.45	17.32	15.32	13.04	11.55							
	1346.43	17.74	15.70	13.36	11.83							
	1561.86	17.32	15.32	13.04	11.55							



	i	Mc [kNm]				n _{1max} [min ⁻¹]	Pt [kW]	Kg				
		n ₂ x h	n ₂ x h	n ₂ x h	n ₂ x h			M	P	CPC	F	FS
		10.000	20.000	50.000	100.000							
PGA 1803	45.04	19.88	18.02	15.28	12.42	2800	17	167	194	217	136	172
	54.40	19.98	17.69	15.04	13.33							
	74.03	17.74	15.70	13.36	11.83							
	85.87	17.32	15.32	13.04	11.55							
	103.64	14.00	12.39	10.56	9.33							
	116.67	14.93	13.93	12.70	11.83							
	135.33	16.98	15.32	13.04	11.55							
	163.33	14.00	12.39	10.56	9.33							
PGA 1804	185.78	20.36	18.02	15.33	13.57	2800	13	169	196	219	138	174
	224.38	19.98	17.69	15.04	13.33							
	281.04	19.98	17.69	15.04	13.33							
	323.86	19.98	17.69	15.04	13.33							
	353.63	19.98	17.69	15.04	13.33							
	394.37	17.75	15.75	13.38	11.84							
	442.93	19.98	17.69	15.04	13.33							
	500.08	17.55	15.54	13.22	11.70							
	558.25	17.32	15.32	13.04	11.55							
	580.74	17.55	15.54	13.22	11.70							
	621.53	17.75	15.75	13.38	11.84							
	700.00	17.74	15.70	13.36	11.83							
	749.17	17.74	15.70	13.36	11.83							
	812.00	17.32	15.32	13.04	11.55							
	981.17	17.32	15.32	13.04	11.55							
	1184.17	14.00	12.39	10.56	9.33							

1800



(n₂ x h = 20.000)

$$M_{\max} = M_C \times 2$$

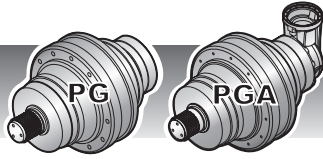

1800

IT EN DE FR ES PT

MS

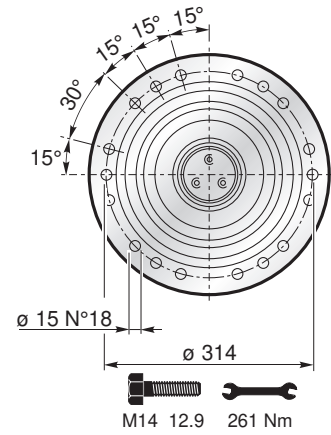
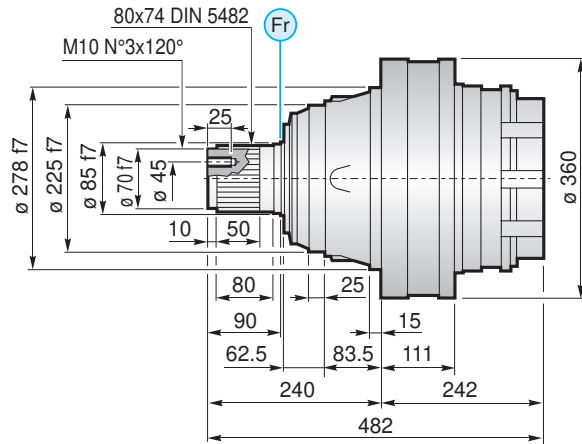
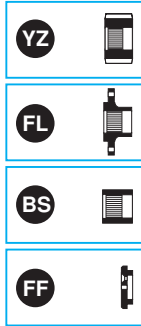

MC

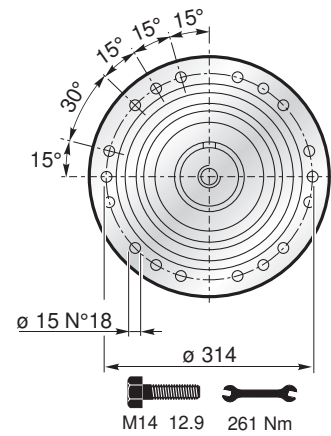
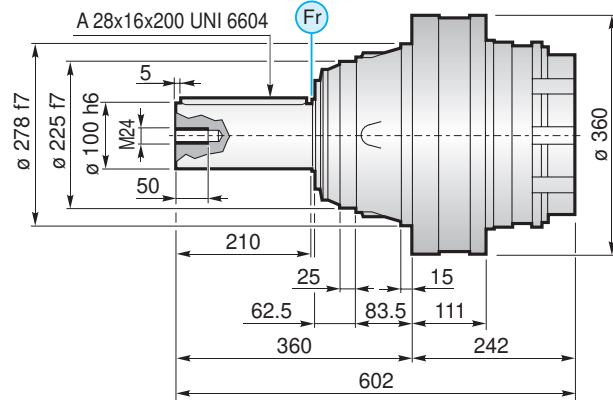

PS

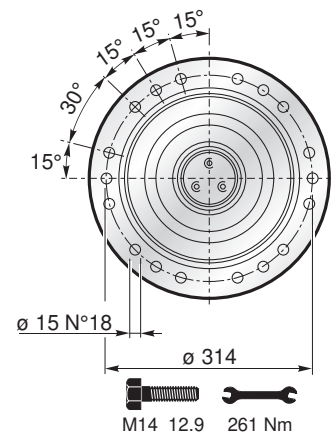
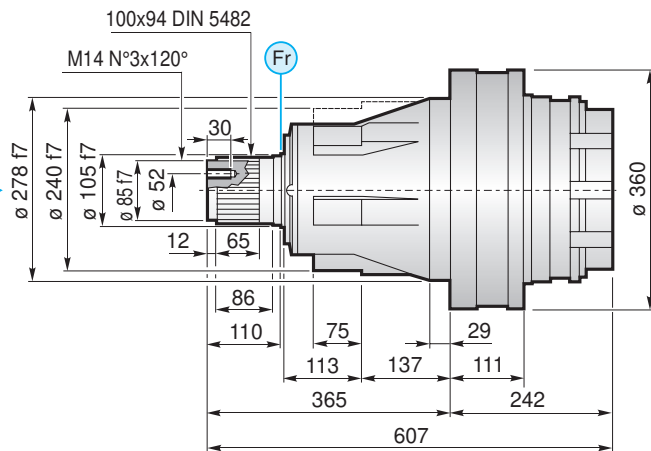
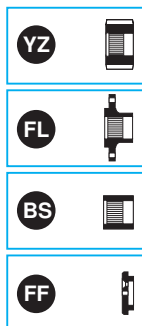

PC

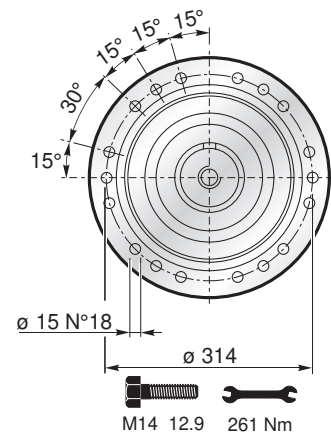
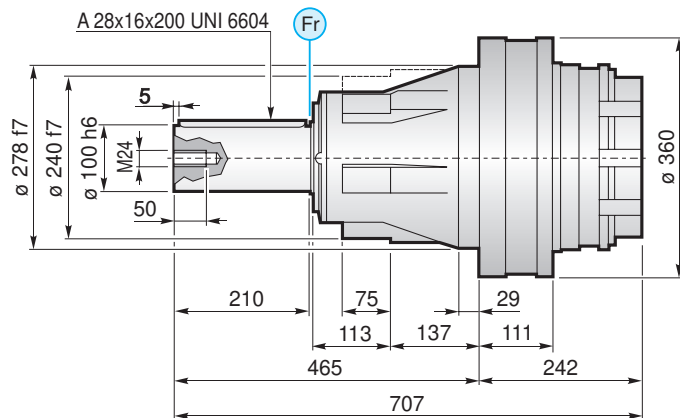

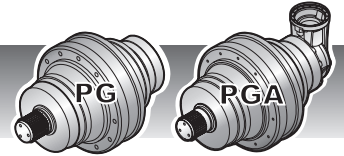

F

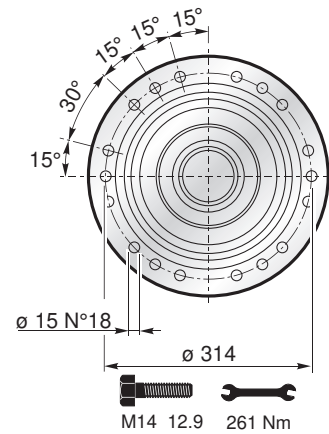
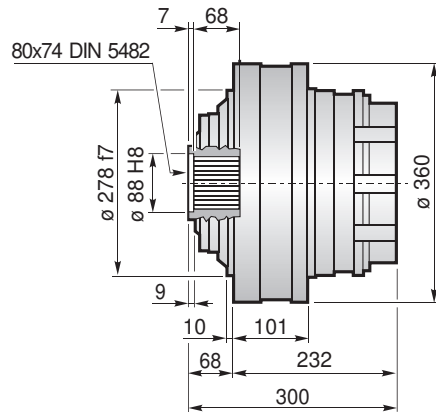
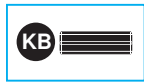

FS

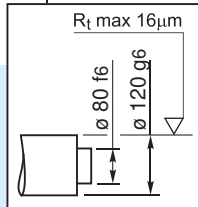
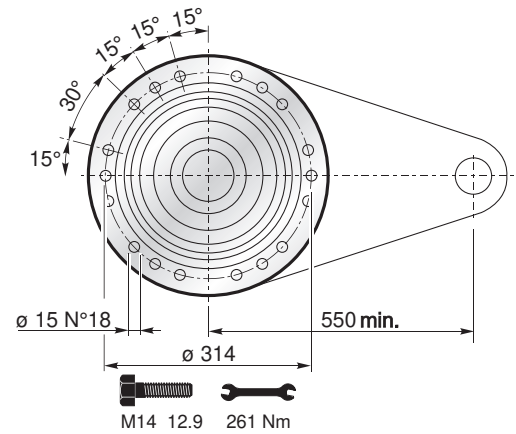
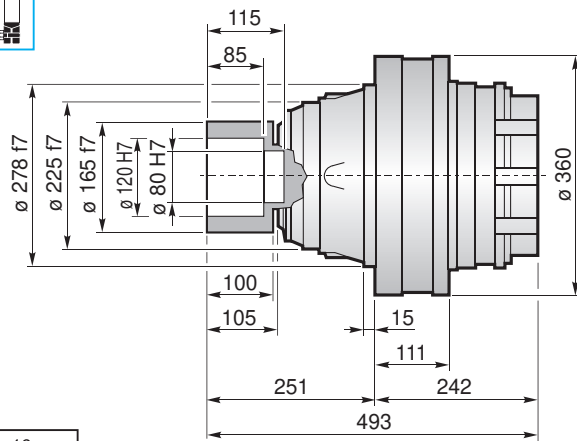

$M_{max} = 35 \text{ kNm}$

La coppia massima indicata è valida solo con calettatori forniti da Planetary Drives
 The maximum torque indicated is valid only with shrink discs supplied by Planetary Drives
 Das dargestellte, maximale Drehmoment gilt nur mit von Planetary Drives gelieferter Schrumpfscheibe
 Le couple maximal indiqué n'est valable qu'avec les frettes de serrage fournis par Planetary Drives
 El momento máximo indicado sólo es válido con discos de contracción suministrados por Planetary Drives
 O torque máximo indicado é válido exclusivamente com discos de contração fornecidos pela Planetary Drives

1800

CPC

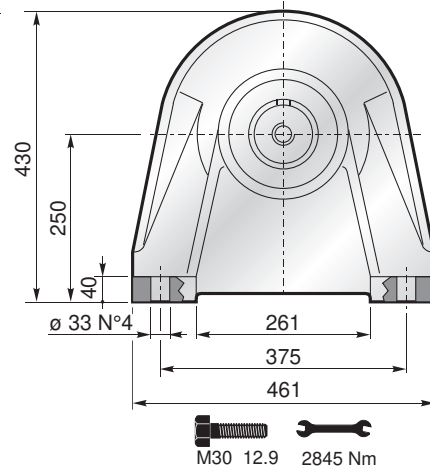
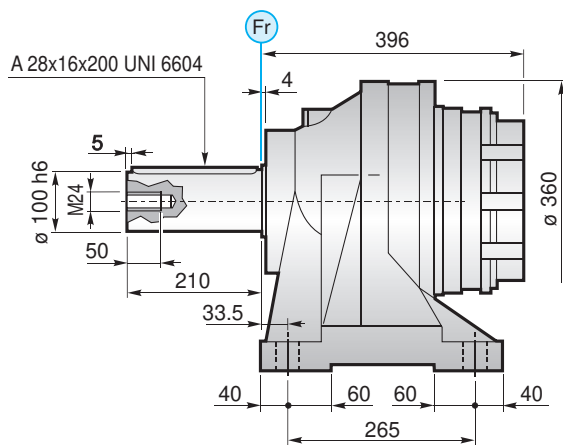

FL YZ BS FF KB GA → B-66



1800

IT EN DE FR ES PT

PG ...MS		A	B	RA	RB	EF	EDF
PG1802	242	482		•			
PG1803	301.5	541.5	•	o	•		
PG1804	345.5	585.5	•			•	

PG ...MC		A	B	RA	RB	EF	EDF
PG1802	242	602		•			
PG1803	301.5	661.5	•	o	•		
PG1804	345.5	705.5	•			•	

PG ...PS		A	B	RA	RB	EF	EDF
PG1802	242	607		•			
PG1803	301.5	666.5	•	o	•		
PG1804	345.5	710.5	•			•	

PG ...PC		A	B	RA	RB	EF	EDF
PG1802	242	707		•			
PG1803	301.5	766.5	•	o	•		
PG1804	345.5	810.5	•			•	

PG ...F		A	B	RA	RB	EF	EDF
PG1802	232	300		•			
PG1803	291.5	359.5	•	o	•		
PG1804	335.5	403.5	•			•	

PG ...FS		A	B	RA	RB	EF	EDF
PG1802	242	493		•			
PG1803	301.5	552.5	•	o	•		
PG1804	345.5	596.5	•			•	

PG ...CPC		A	B	RA	RB	EF	EDF
PG1802	396	606		•			
PG1803	455.5	665.5	•	o	•		
PG1804	503.5	713.5	•			•	

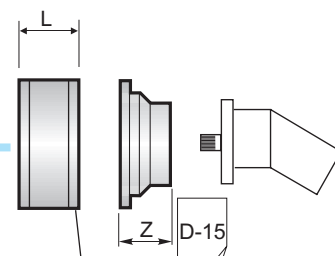
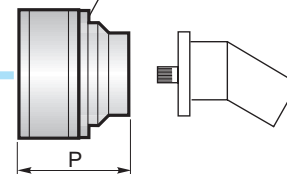
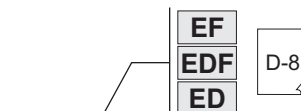
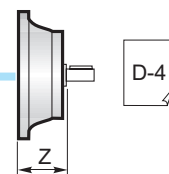
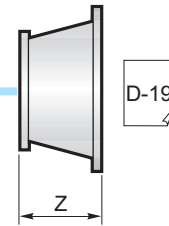
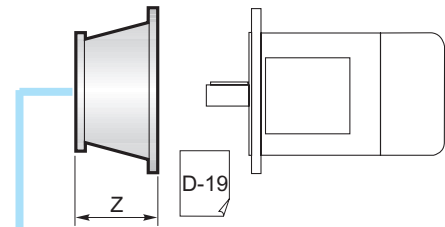

D-2	RA	RB	L
			81
			125

!	A+13.5	B+13.5	o
---	--------	--------	---



	PGA ...MS				
	A	B	RA	RB	EF
PGA 1802	277	315		•	
PGA 1803	334	240	•	o	•
PGA 1804	407	240	•		•

	PGA ...MC				
	A	B	RA	RB	EF
PGA 1802	277	315		•	
PGA 1803	334	240	•	o	•
PGA 1804	407	240	•		•

	PGA ...PS				
	A	B	RA	RB	EF
PGA 1802	277	315		•	
PGA 1803	334	240	•	o	•
PGA 1804	407	240	•		•

	PGA ...PC				
	A	B	RA	RB	EF
PGA 1802	277	315		•	
PGA 1803	334	240	•	o	•
PGA 1804	407	240	•		•

	PGA ...F				
	A	B	RA	RB	EF
PGA 1802	267	315		•	
PGA 1803	324	240	•	o	•
PGA 1804	397	240	•		•

	PGA ...FS				
	A	B	RA	RB	EF
PGA 1802	277	315		•	
PGA 1803	334	240	•	o	•
PGA 1804	407	240	•		•

	PGA ...CPC				
	A	B	RA	RB	EF
PGA 1802	431	315		•	
PGA 1803	484	240	•	o	•
PGA 1804	543.5	240	•		•

	B+16.5	o
--	--------	---

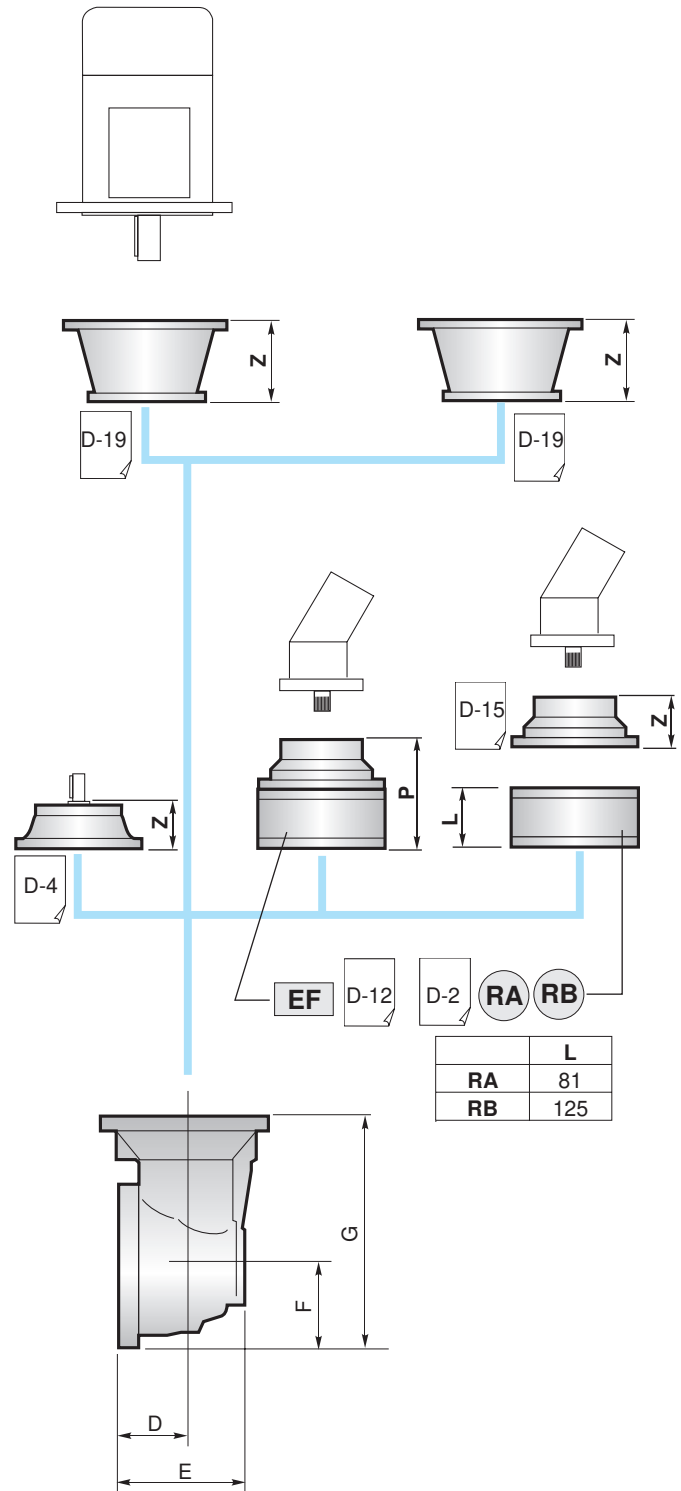

	D	E	F	G
PGA 1803	88	164	140	380
PGA 1804	88	164	140	380

1800

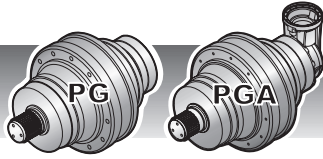

1800

IT EN DE FR ES PT

YZ Pignoni / Pinion
Ritzel / Pignon
Piñones / Pinhões

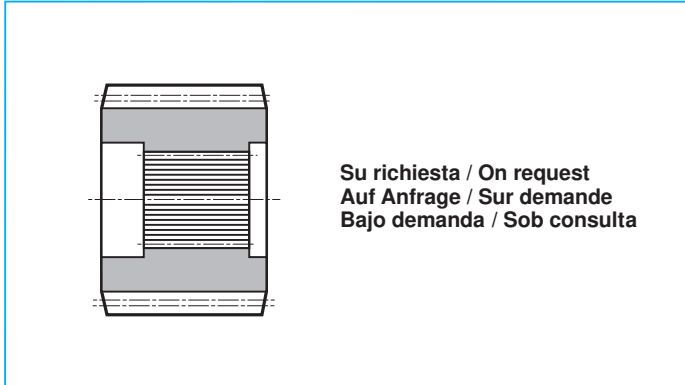

Su richiesta / On request
Auf Anfrage / Sur demande
Bajo demanda / Sob consulta

FF Fondello di arresto / Stop bottom plate
Endscheibe / Bouchon de fermeture
Tapón de detención / Fundo de batente

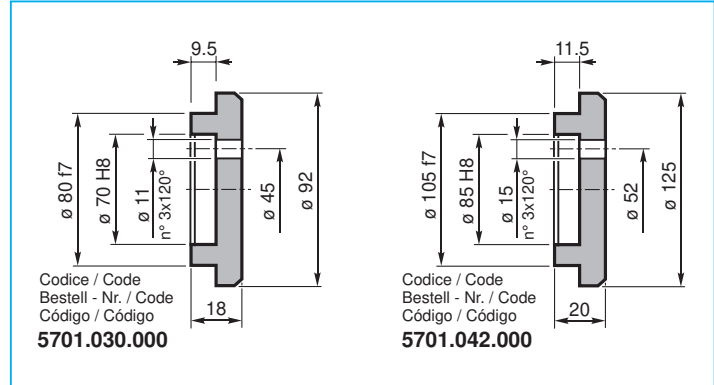

Codice / Code
Bestell - Nr. / Code
Código / Código
5701.030.000

Codice / Code
Bestell - Nr. / Code
Código / Código
5701.042.000

BS Boccola scanalata / Splined bushing
Innenverzähnte Buchse / Moyeu cannelé
Casquillo ranurado / Bucha estriada

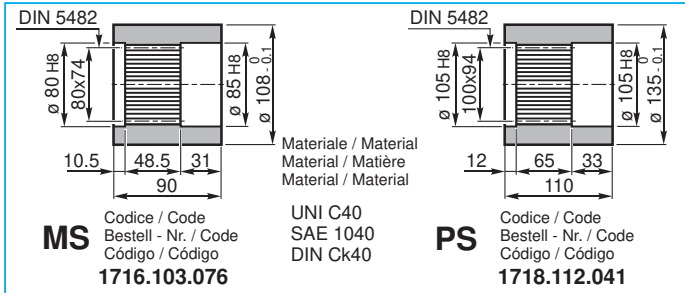

MS Codice / Code
Bestell - Nr. / Code
Código / Código
1716.103.076

Material / Material
Material / Matière
Material / Material
UNI C40
SAE 1040
DIN Ck40

PS Codice / Code
Bestell - Nr. / Code
Código / Código
1718.112.041

KB Barra scanalata / Splined rod
Außenverzähnte Welle / Arbre cannelé
Barra ranurada / Barra estriada

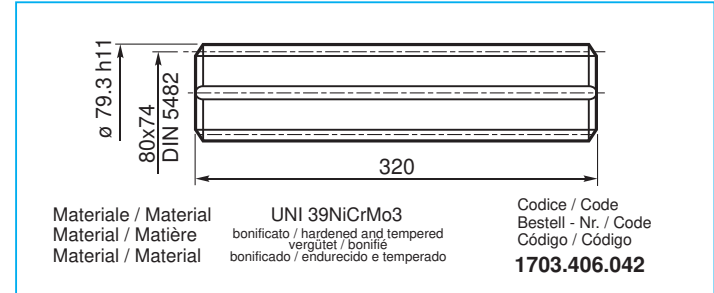

Material / Material
Material / Matière
Material / Material

UNI 39NiCrMo3
bonificato / hardened and tempered
vergütet / bonifié
bonificado / endurecido e temperado

Codice / Code
Bestell - Nr. / Code
Código / Código
1703.406.042

FL Flangia / Flange
Flansch / Bride
Brida / Flange

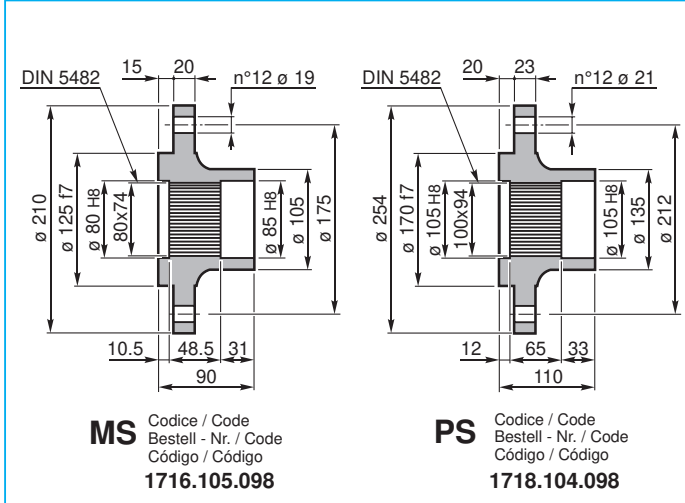

MS Codice / Code
Bestell - Nr. / Code
Código / Código
1716.105.098

PS Codice / Code
Bestell - Nr. / Code
Código / Código
1718.104.098

GA Giunto di attrito / Shrink disc
Schrumpfscheibe / Frette de serrage
Disco de contracción / Disco de contração

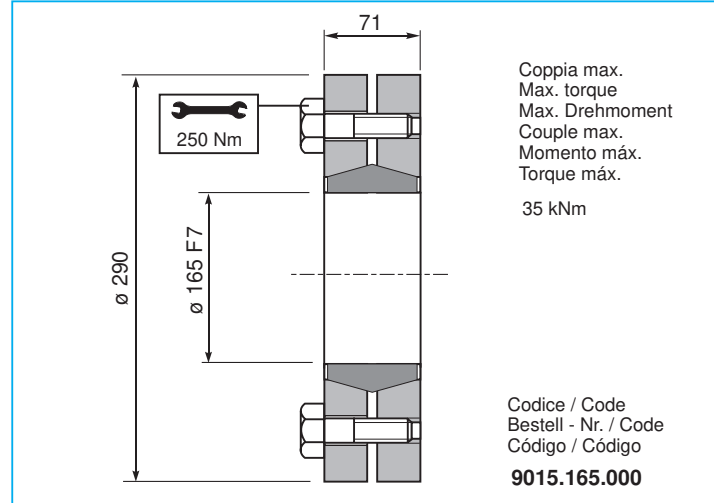

Coppia max.
Max. torque
Max. Drehmoment
Couple max.
Momento máx.
Torque máx.
35 kNm

Codice / Code
Bestell - Nr. / Code
Código / Código
9015.165.000

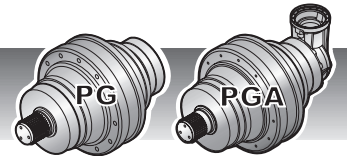

CARICHI RADIALI (Fr)

Nei diagrammi seguenti sono riportati i carichi radiali e i coefficienti K per rapportarli al valore $n_2 \times h$ desiderato.

RADIAL LOADS (Fr)

The following curves show the radial loads and the K factors to obtain the required $n_2 \times h$ value.

RADIALLAST (Fr)

In den nachstehenden Diagrammen ist die Radiallast und der Koeffizient K dargestellt und kann mit dem gewünschten Wert $n_2 \times h$ verglichen werden.

CHARGES RADIALES (Fr)

Dans les diagrammes suivants sont indiqués les charges radiales et les facteurs K de façon à obtenir la valeur $n_2 \times h$ désirée.

CARGAS RADIALES (Fr)

En los siguientes diagramas se indican las cargas radiales y los coeficientes K para obtener el valor requerido $n_2 \times h$.

CARGAS RADIAIS (Fr)

Nos diagramas seguintes são indicadas as cargas radiais e os coeficientes K para obter o valor $n_2 \times h$ desejado.

M - CPC* - P

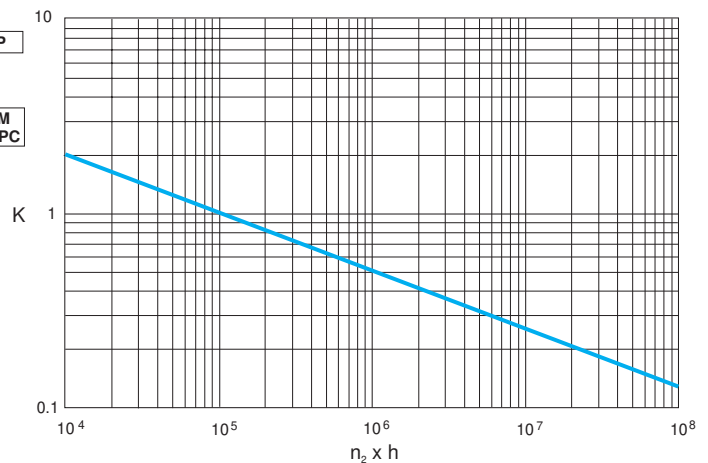
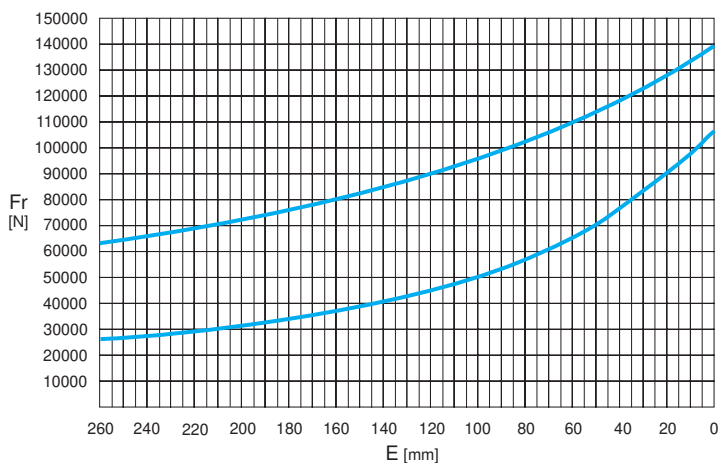

	$n_2 \times h$			
	10^5	10^4	10^6	10^7
M - P	Fr		Fr • K	
*CPC	Fr • 0.75		Fr • K • 0.75	

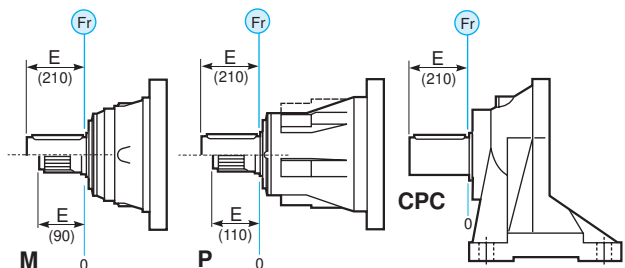

CARICHI ASSIALI (Fa)

I valori dei carichi assiali indicati in tabella sono riferiti alle versioni e alla direzione di applicazione del carico.

AXIAL LOADS (Fa)

The values of the axial loads in the table refer to the output versions and load direction of application.

AXIALLAST (Fa)

Die dargestellten Werte der Axiallast basieren auf der Version und der applizierten Lastrichtung.

CHARGES AXIALES (Fa)

Les valeurs des charges axiales indiquées dans le tableau se réfèrent aux versions et à la direction d'application de la charge.

CARGAS AXIALES (Fa)

Los valores de las cargas axiales indicados en la tabla se refieren a las versiones y a la dirección de aplicación de la carga.

CARGAS AXIAIS (Fa)

Os valores das cargas axiais indicadas na tabela referem-se às versões e à direção de aplicação da carga.

Fa [N]	M - CPC	P	← →
	45000	85000	
65000		85000	

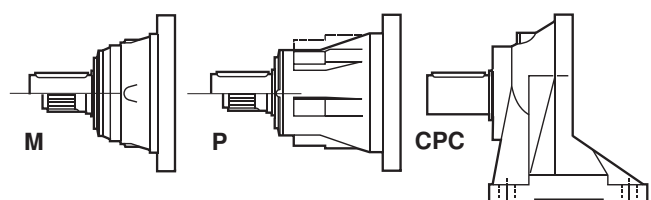



2500

IT EN DE FR ES PT

	i	Mc [kNm]				n _{1max} [min ⁻¹]	Pt [kW]	Kg				
		n ₂ x h	n ₂ x h	n ₂ x h	n ₂ x h			M	P	CPC	F	FS
		10.000	20.000	50.000	100.000							
PG 2501	4.00	34.75	30.76	26.18	23.17	1500	50	183	-	244	147	155
	5.20	26.87	23.78	20.24	17.91							
	6.25	20.73	18.35	15.62	13.82							
PG 2502	14.67	24.11	21.35	18.15	16.09	2800	30	210	-	271	174	182
	17.71	22.01	19.49	16.57	14.69							
	19.07	26.87	23.78	20.24	17.91							
	23.03	26.87	23.78	20.24	17.91							
	26.00	24.01	21.25	18.08	16.00							
	31.25	20.73	18.35	15.62	13.82							
	36.25	20.73	18.35	15.62	13.82							
	43.75	19.11	16.91	14.41	12.74							
PG 2503	55.41	24.11	21.35	18.15	16.09	2800	20	222	-	283	186	194
	60.50	24.11	21.35	18.15	16.09							
	72.03	26.87	23.78	20.24	17.91							
	87.00	26.87	23.78	20.24	17.91							
	94.99	26.87	23.78	20.24	17.91							
	107.25	24.01	21.25	18.08	16.00							
	114.40	26.86	23.77	20.24	17.91							
	118.98	26.87	23.78	20.24	17.91							
	134.33	24.01	21.25	18.08	16.00							
	156.00	24.01	21.25	18.08	16.00							
	166.96	24.28	21.54	18.30	16.19							
	188.50	24.01	21.25	18.08	16.00							
	218.66	20.31	17.97	15.29	13.55							
	226.56	20.73	18.35	15.62	13.82							
	262.81	20.73	18.35	15.62	13.82							
	317.19	19.11	16.91	14.41	12.74							
PG 2504	337.75	26.87	23.78	20.24	17.91	2800	15	228	-	289	192	200
	372.84	26.87	23.78	20.24	17.91							
	407.11	26.87	23.78	20.24	17.91							
	423.04	26.87	23.78	20.24	17.91							
	459.64	24.01	21.25	18.08	16.00							
	493.23	22.01	19.49	16.57	14.69							
	575.71	24.01	21.25	18.08	16.00							
	600.60	24.01	21.25	18.08	16.00							
	670.22	24.01	21.25	18.08	16.00							
	723.94	24.01	21.25	18.08	16.00							
	807.86	24.01	21.25	18.08	16.00							
	873.60	24.01	21.25	18.08	16.00							
	934.96	24.28	21.54	18.30	16.19							
	1031.17	24.07	21.24	17.94	16.05							
	1126.96	24.28	21.54	18.30	16.19							
	1272.38	24.01	21.25	18.08	16.00							
	1352.00	24.01	21.25	18.08	16.00							
	1446.96	24.28	21.54	18.30	16.19							
	1529.30	20.73	18.35	15.62	13.82							
	1633.67	24.01	21.25	18.08	16.00							
	1773.98	20.73	18.35	15.62	13.82							
	1885.00	20.73	18.35	15.62	13.82							
	1963.54	20.73	18.35	15.62	13.82							
	2277.71	20.73	18.35	15.62	13.82							



	i	Mc [kNm]				n _{1max} [min ⁻¹]	Pt [kW]	Kg				
		n ₂ x h	n ₂ x h	n ₂ x h	n ₂ x h			M	P	CPC	F	FS
		10.000	20.000	50.000	100.000							
PGA 2502	12.29	27.63	24.55	18.65	15.16	2000	30	279	-	340	242	250
	15.97	26.87	23.78	20.24	17.91							
	19.20	20.73	18.35	15.62	13.82							
	24.27	22.48	21.15	19.52	16.58							
	29.17	20.73	18.35	15.62	13.82							
PGA 2503	50.67	22.01	20.04	16.60	13.48	2800	20	247	-	308	211	219
	61.19	22.01	19.49	16.57	14.69							
	65.87	26.87	23.78	19.94	16.20							
	79.55	26.87	23.78	20.24	17.91							
	89.82	24.01	21.25	18.08	16.00							
	95.62	20.73	18.35	15.62	13.82							
	104.19	20.31	17.97	15.29	13.55							
	125.23	20.73	18.35	15.62	13.82							
	151.14	19.11	16.91	14.41	12.74							
	164.20	20.07	17.97	15.29	13.55							
	197.36	20.73	18.35	15.62	13.82							
	238.19	19.11	16.91	14.41	12.74							
	PGA 2504	248.83	26.87	23.78	20.24							
271.70		26.87	23.78	20.24	17.91							
301.66		24.11	21.35	18.15	16.09							
340.31		26.87	23.78	20.24	17.91							
395.20		26.86	23.77	20.24	17.91							
464.06		24.01	21.25	18.08	16.00							
498.30		22.01	19.49	16.57	14.69							
538.91		24.01	21.25	18.08	16.00							
583.92		24.01	21.25	18.08	16.00							
651.18		24.01	21.25	18.08	16.00							
731.37		24.01	21.25	18.08	16.00							
752.27		26.87	23.78	20.24	17.91							
849.33		24.01	21.25	18.08	16.00							
908.99		24.28	21.54	18.30	16.19							
1026.28		24.01	21.25	18.08	16.00							
1190.48		20.31	17.97	15.29	13.55							
1430.87		20.73	18.35	15.62	13.82							
1726.91		19.11	16.91	14.41	12.74							

2500



(n₂ x h = 20.000)

$$M_{\max} = M_c \times 2$$

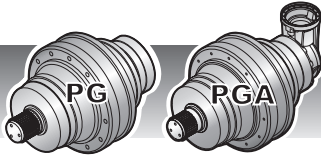

2500

IT EN DE FR ES PT

MS

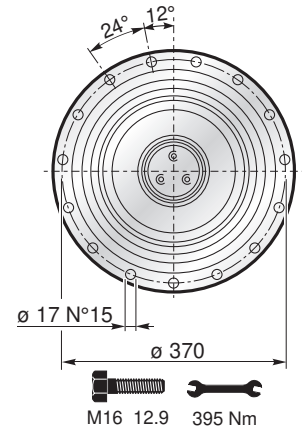
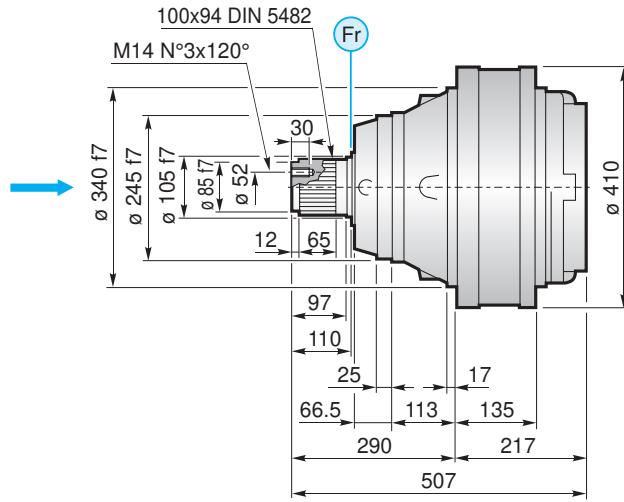
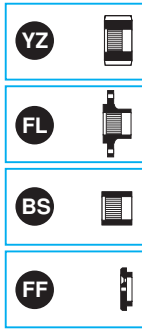

MC

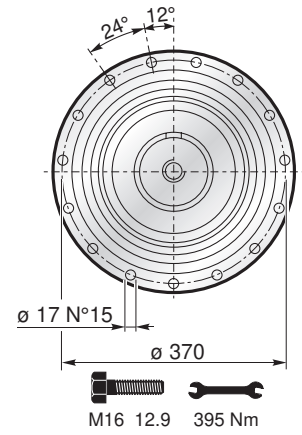
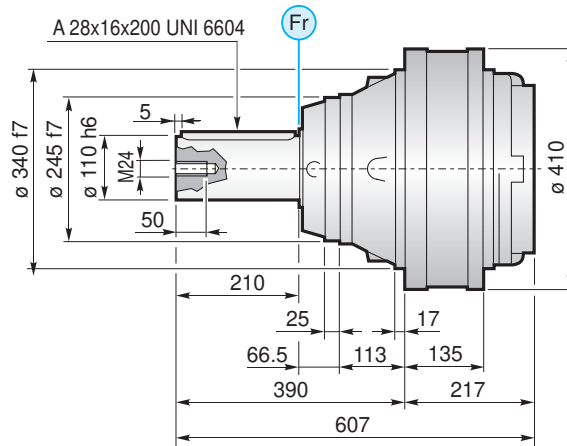

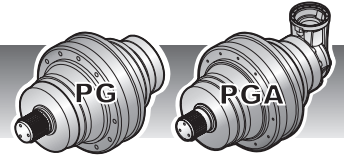

F

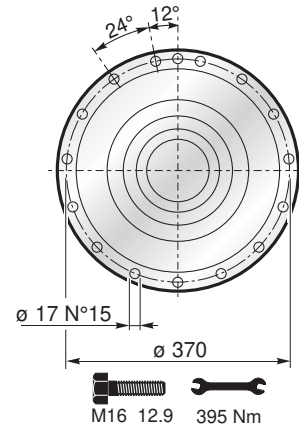
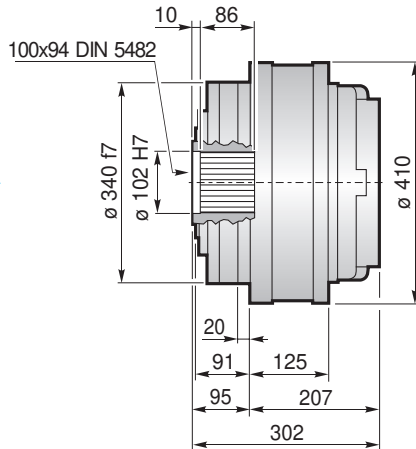
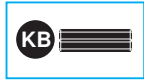

FS

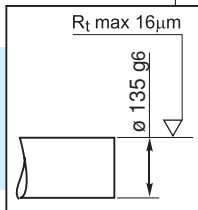
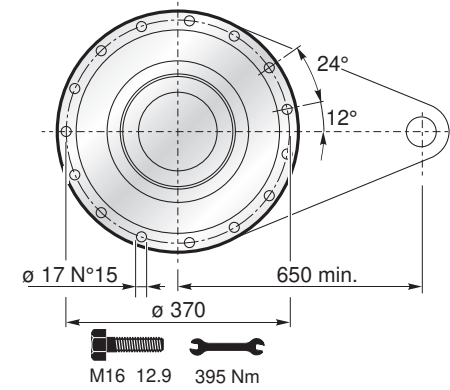
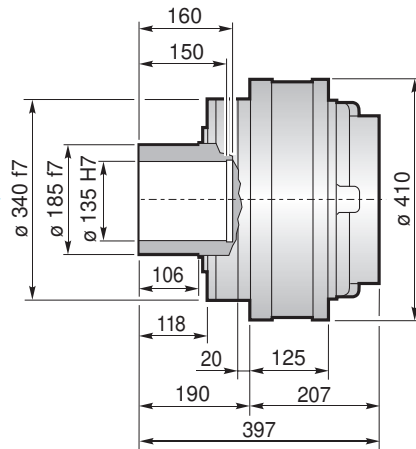

$M_{max} = 52 \text{ kNm}$

La coppia massima indicata è valida solo con calettatori forniti da Planetary Drives
 The maximum torque indicated is valid only with shrink discs supplied by Planetary Drives
 Das dargestellte, maximale Drehmoment gilt nur mit von Planetary Drives gelieferter Schrumpfscheibe
 Le couple maximal indiqué n'est valable qu'avec les frettes de serrage fournies par Planetary Drives
 El momento máximo indicado sólo es válido con discos de contracción suministrados por Planetary Drives
 O torque máximo indicado é válido exclusivamente com discos de contração fornecidos pela Planetary Drives

CPC

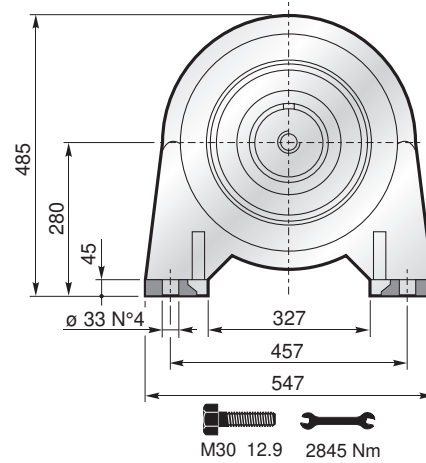
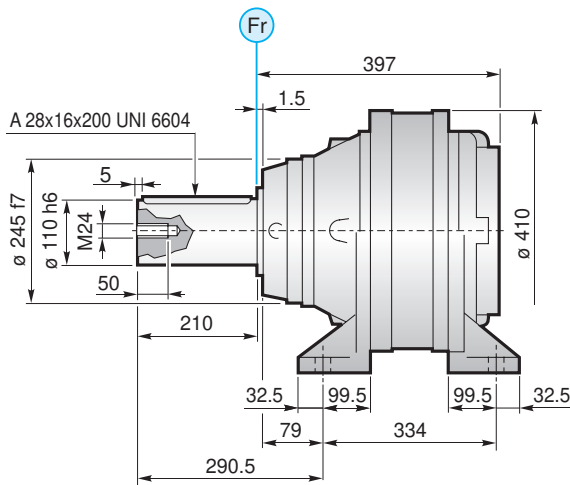

FL YZ BS FF KB GA → B-74



2500

IT EN DE FR ES PT

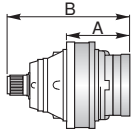
	PG ...MS					
	A	B	RA	RB	EF	EDF
PG 2501	217	507				
PG 2502	311	601		•		
PG 2503	370.5	660.5	•	o	•	
PG 2504	418.5	708.5	•			•

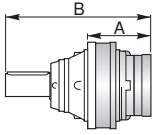
	PG ...MC					
	A	B	RA	RB	EF	EDF
PG 2501	217	607				
PG 2502	311	701		•		
PG 2503	370.5	760.5	•	o	•	
PG 2504	418.5	808.5	•			•

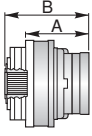
	PG ...F					
	A	B	RA	RB	EF	EDF
PG 2501	207	302				
PG 2502	301	396		•		
PG 2503	360.5	455.5	•	o	•	
PG 2504	408.5	503.5	•			•

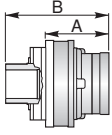
	PG ...FS					
	A	B	RA	RB	EF	EDF
PG 2501	207	397				
PG 2502	301	491		•		
PG 2503	360.5	550.5	•	o	•	
PG 2504	408.5	598.5	•			•

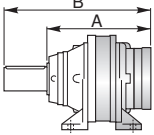
	PG ...CPC					
	A	B	RA	RB	EF	EDF
PG 2501	397	607				
PG 2502	491	701		•		
PG 2503	550.5	760.5	•	o	•	
PG 2504	598.5	808.5	•			•

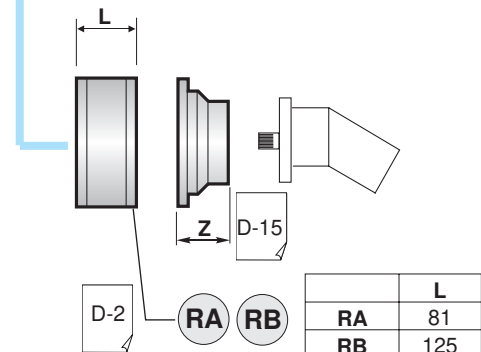
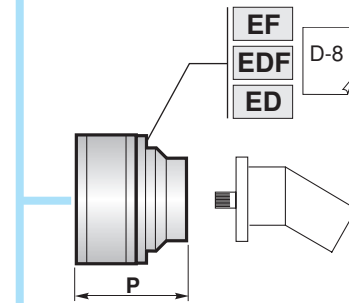
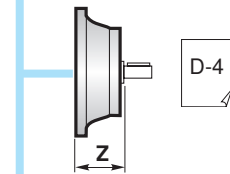
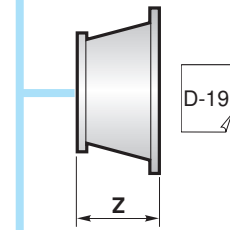
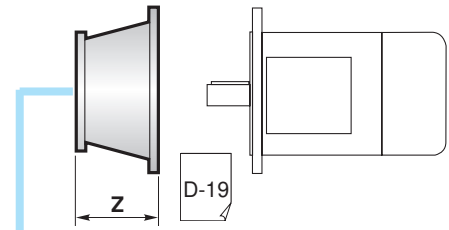

!	A+13.5	B+13.5	o
---	--------	--------	---



	PGA ...MS		RA	RB	EF
	A	B			
PGA 2502	297	315			
PGA 2503	399	240			
PGA 2504	472	240			

	PGA ...MC		RA	RB	EF
	A	B			
PGA 2502	297	315			
PGA 2503	399	240			
PGA 2504	472	240			

	PGA ...F		RA	RB	EF
	A	B			
PGA 2502	287	315		•	
PGA 2503	389	240	•	o	
PGA 2504	462	240	•		•

	PGA ...FS		RA	RB	EF
	A	B			
PGA 2502	287	315			
PGA 2503	389	240			
PGA 2504	462	240			

	PGA ...CPC		RA	RB	EF
	A	B			
PGA 2502	477	315			
PGA 2503	579	240			
PGA 2504	638.5	240			

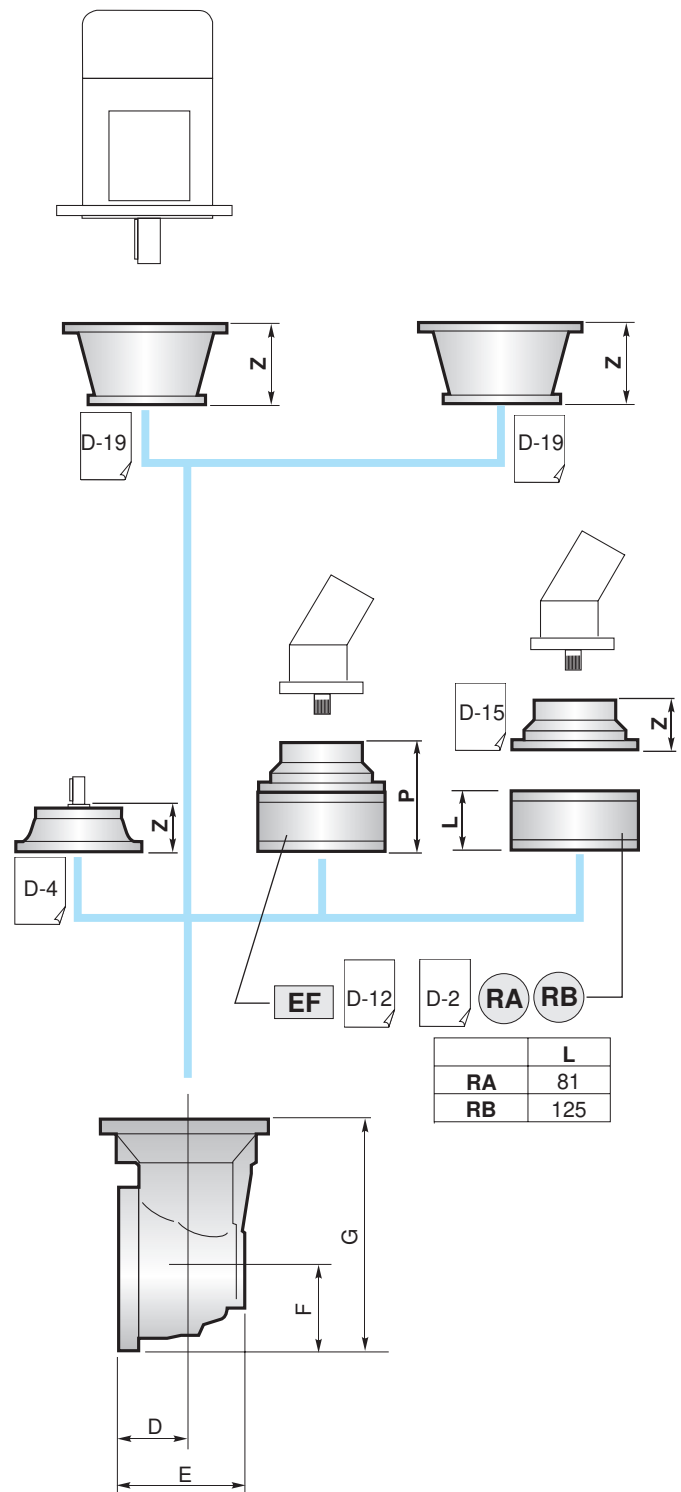

2500

	D	E	F	G
PGA 2502	88	256	235	550
PGA 2503	88	164	140	380
PGA 2504	88	164	140	380

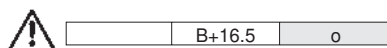

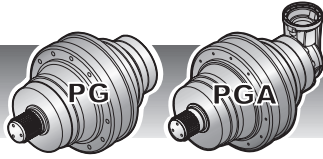

2500

IT EN DE FR ES PT

BS Boccola scanalata / Splined bushing
Innenverzahnte Buchse / Moyeu cannelé
Casquillo ranurado / Bucha estriada

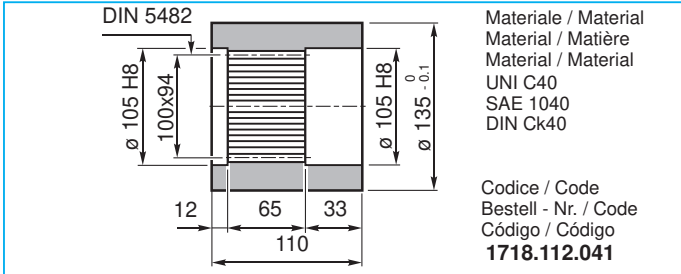

KB Barra scanalata / Splined rod
Außenverzahnte Welle / Arbre cannelé
Barra ranurada / Barra estriada

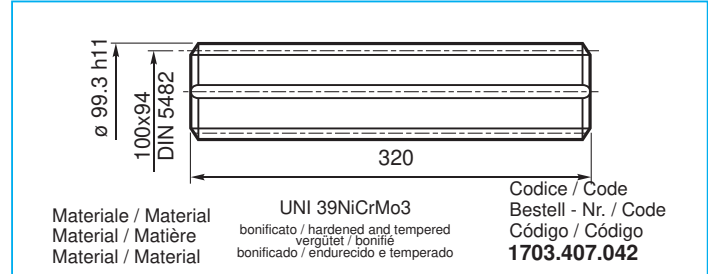

FL Flangia / Flange
Flansch / Bride
Brida / Flange

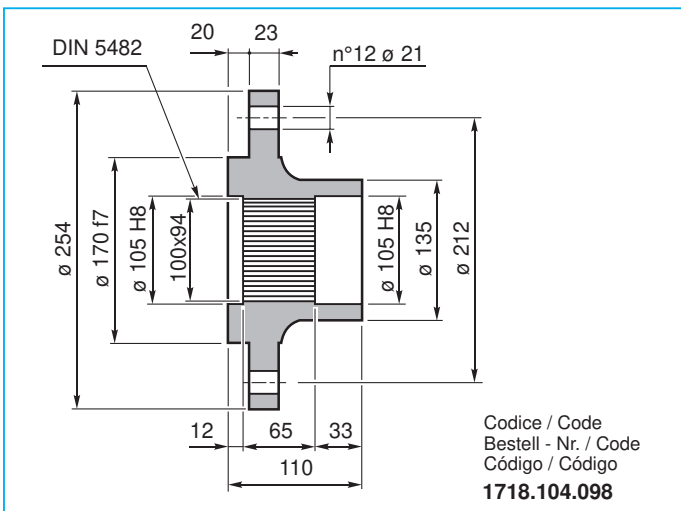

GA Giunto di attrito / Shrink disc
Schrumpfscheibe / Frette de serrage
Disco de contracción / Disco de contração

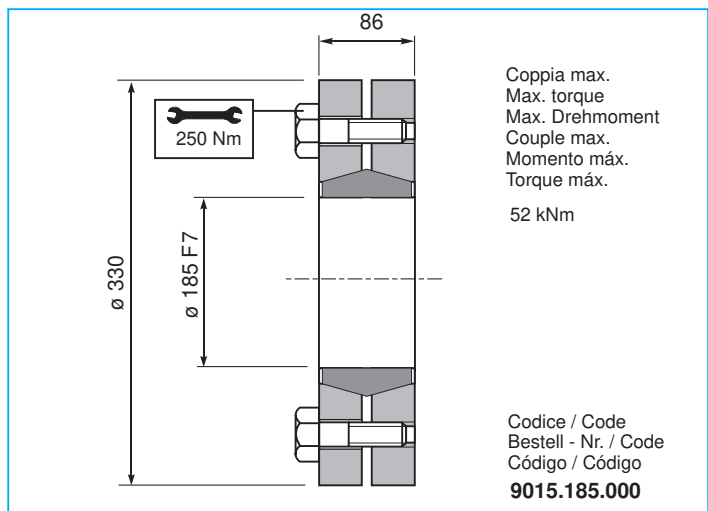

FF Fondello di arresto / Stop bottom plate
Endscheibe / Bouchon de fermeture
Tapón de detención / Fundo de batente

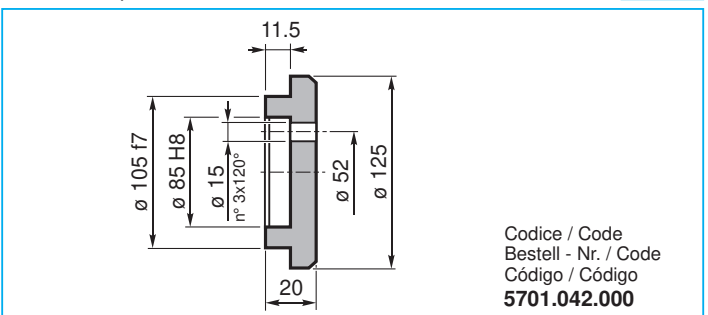

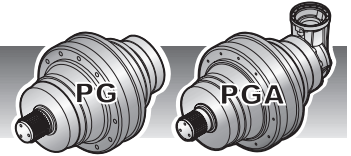

CARICHI RADIALI (Fr)

Nei diagrammi seguenti sono riportati i carichi radiali e i coefficienti K per rapportarli al valore $n_2 \times h$ desiderato.

RADIAL LOADS (Fr)

The following curves show the radial loads and the K factors to obtain the required $n_2 \times h$ value.

RADIALLAST (Fr)

In den nachstehenden Diagrammen ist die Radiallast und der Koeffizient K dargestellt und kann mit dem gewünschten Wert $n_2 \times h$ verglichen werden.

CHARGES RADIALES (Fr)

Dans les diagrammes suivants sont indiqués les charges radiales et les facteurs K de façon à obtenir la valeur $n_2 \times h$ désirée.

CARGAS RADIALES (Fr)

En los siguientes diagramas se indican las cargas radiales y los coeficientes K para obtener el valor requerido $n_2 \times h$.

CARGAS RADIAIS (Fr)

Nos diagramas seguintes são indicadas as cargas radiais e os coeficientes K para obter o valor $n_2 \times h$ desejado.

M - CPC

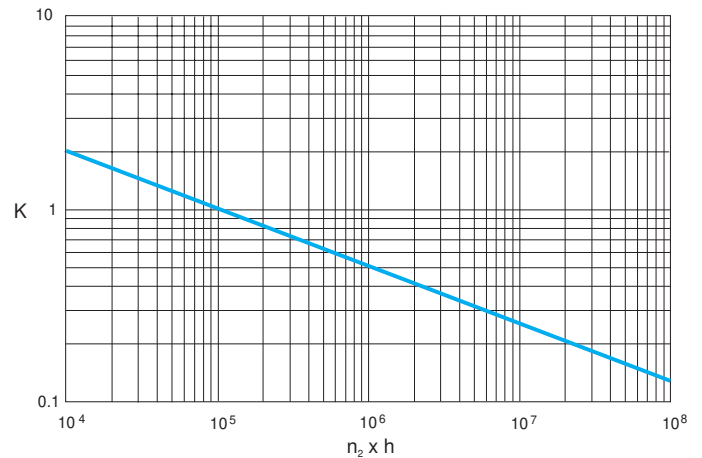
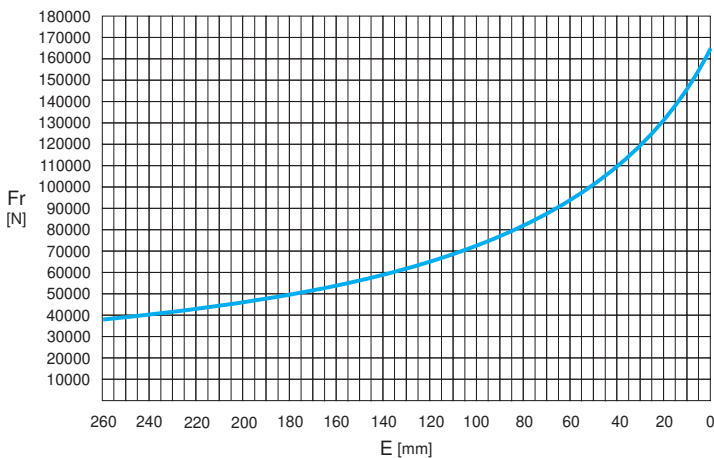

	$n_2 \times h$				
	10^5	10^4	10^6	10^7	10^8
M	Fr		Fr • K		
*CPC	Fr • 0.75		Fr • K • 0.75		

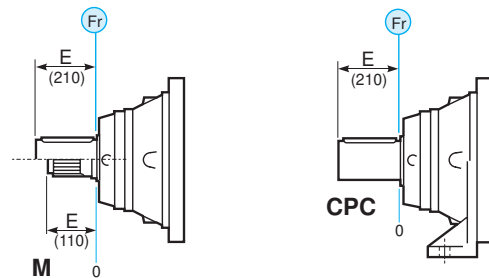

CARICHI ASSIALI (Fa)

I valori dei carichi assiali indicati in tabella sono riferiti alle versioni e alla direzione di applicazione del carico.

AXIAL LOADS (Fa)

The values of the axial loads in the table refer to the output versions and load direction of application.

AXIALLAST (Fa)

Die dargestellten Werte der Axiallast basieren auf der Version und der applizierten Lastrichtung.

CHARGES AXIALES (Fa)

Les valeurs des charges axiales indiquées dans le tableau se réfèrent aux versions et à la direction d'application de la charge.

CARGAS AXIALES (Fa)

Los valores de las cargas axiales indicados en la tabla se refieren a las versiones y a la dirección de aplicación de la carga.

CARGAS AXIAIS (Fa)

Os valores das cargas axiais indicadas na tabela referem-se às versões e à direção de aplicação da carga.

Fa [N]	M	CPC	← →
	75000	75000	
95000	95000	95000	

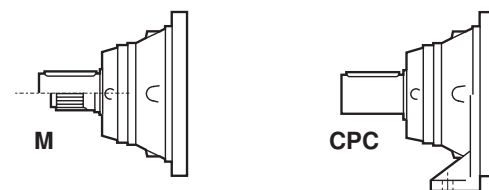



3000

IT EN DE FR ES PT

i	Mc [kNm]				n _{1max} [min ⁻¹]	Pt [kW]	Kg					
	n ₂ x h	n ₂ x h	n ₂ x h	n ₂ x h			M	P	CPC	F	FS	
	10.000	20.000	50.000	100.000								
PG 3002	14.22	34.75	30.76	26.18	2000	34	237	-	298	196	204	
	17.14	34.75	30.76	26.18								23.17
	22.40	28.02	24.80	21.09								18.69
	29.12	26.87	23.78	20.24								17.91
	35.10	26.56	23.51	20.00								17.70
PG 3003	53.73	34.75	30.76	26.18	2800	23	253	-	314	212	220	
	64.76	34.75	30.76	26.18								23.17
	73.48	34.75	30.76	26.18								23.17
	88.57	34.75	30.76	26.18								23.17
	102.86	34.75	30.76	26.18								23.17
	124.29	28.88	25.55	21.73								19.29
	134.40	28.02	24.80	21.09								18.69
	150.45	26.87	23.78	20.24								17.91
	181.35	26.56	23.51	20.00								17.70
	211.12	26.87	23.78	20.24								17.91
PG 3004	230.26	34.75	30.76	26.18	2800	17	261	-	322	220	228	
	251.43	34.75	30.76	26.18								23.17
	300.88	33.31	29.42	25.04								22.13
	314.92	34.75	30.76	26.18								23.17
	328.53	34.75	30.76	26.18								23.17
	362.67	34.75	30.76	26.18								23.17
	379.59	34.75	30.76	26.18								23.17
	396.00	34.75	30.76	26.18								23.17
	411.50	34.75	30.76	26.18								23.17
	440.82	34.75	30.76	26.18								23.17
	477.32	34.45	30.49	25.92								22.87
	517.44	28.02	24.80	21.09								18.69
	576.00	34.75	30.76	26.18								23.17
	623.70	28.02	24.80	21.09								18.69
	694.29	34.75	30.76	26.18								23.17
	752.64	28.02	24.80	21.09								18.69
	838.93	28.88	25.55	21.73								19.29
	1015.56	26.87	23.78	20.24								17.91
	1425.06	26.87	23.78	20.24								17.91



	i	Mc [kNm]				n _{1max} [min ⁻¹]	Pt [kW]	Kg				
		n ₂ x h	n ₂ x h	n ₂ x h	n ₂ x h			M	P	CPC	F	FS
		10.000	20.000	50.000	100.000							
PGA 3003	43.68	34.75	30.76	26.18	23.17	2800	23	336	-	397	299	307
	52.65	34.75	30.76	26.18	23.17							
	66.37	34.75	30.76	26.18	23.17							
	80.00	34.75	30.76	26.18	23.17							
	104.53	28.02	24.80	21.09	18.69							
	135.89	26.87	23.78	20.24	17.91							
	163.80	26.56	23.51	20.00	17.70							
PGA 3004	202.67	34.75	30.76	26.18	23.17	2800	17	293	-	354	252	260
	253.85	34.75	30.76	26.18	23.17							
	305.97	34.75	30.76	26.18	23.17							
	352.59	34.75	30.76	26.18	23.17							
	385.00	34.75	30.76	26.18	23.17							
	464.59	31.64	28.03	23.84	21.15							
	503.07	28.02	24.80	21.09	18.69							
	560.00	34.75	30.76	26.18	23.17							
	603.97	26.87	23.78	20.24	17.91							
	676.67	28.88	25.55	21.73	19.29							
	731.73	28.02	24.80	21.09	18.69							
	819.13	26.87	23.78	20.24	17.91							
	951.25	26.87	23.78	20.24	17.91							
	1149.43	26.87	23.78	20.24	17.91							
	1385.48	26.56	23.51	20.00	17.70							

3000



(n₂ x h = 20.000)

$$M_{\max} = M_C \times 2$$

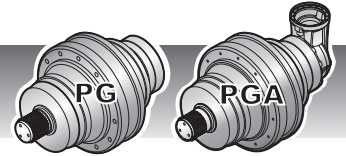

F

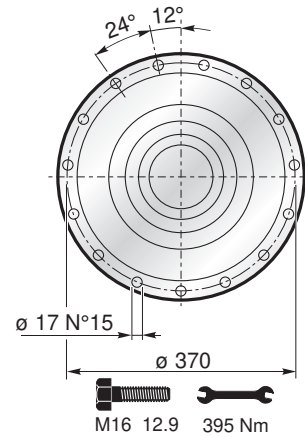
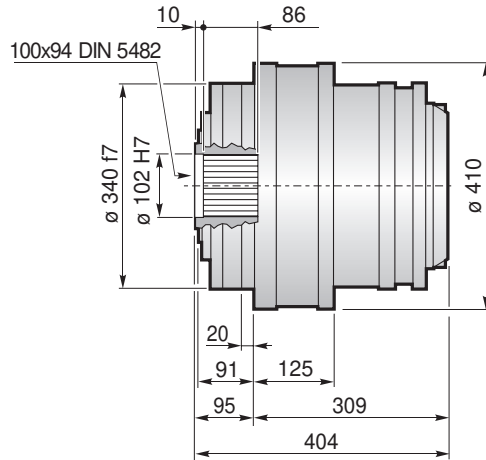
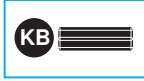

FS

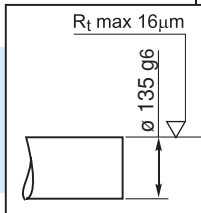
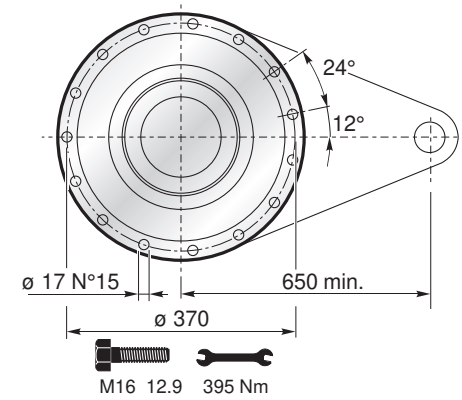
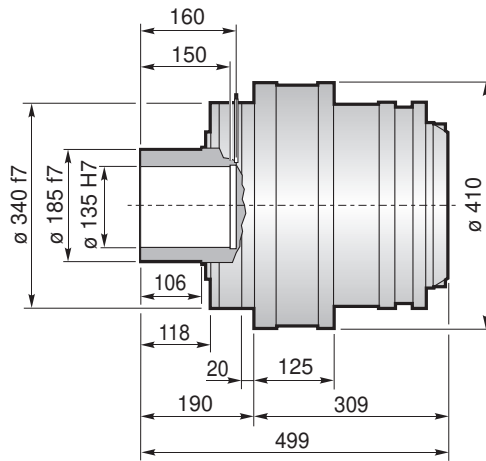

$M_{max} = 52 \text{ kNm}$

La coppia massima indicata è valida solo con calettatori forniti da Planetary Drives
 The maximum torque indicated is valid only with shrink discs supplied by Planetary Drives
 Das dargestellte, maximale Drehmoment gilt nur mit von Planetary Drives gelieferter Schrumpfscheibe
 Le couple maximal indiqué n'est valable qu'avec les frettes de serrage fournis par Planetary Drives
 El momento máximo indicado sólo es válido con discos de contracción suministrados por Planetary Drives
 O torque máximo indicado é válido exclusivamente com discos de contração fornecidos pela Planetary Drives

3000

CPC

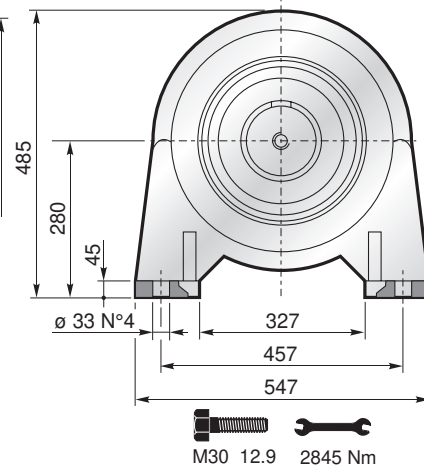
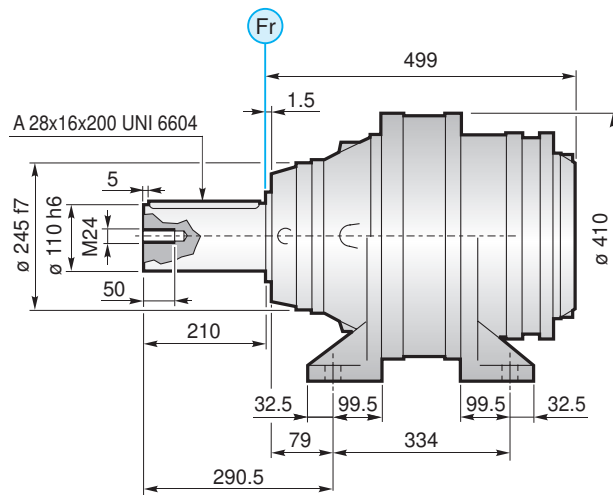

FL YZ BS FF KB GA → B-82



3000

IT EN DE FR ES PT

	PG ...MS					
	A	B	RA	RB	EF	EDF
PG 3002	319	609		•		
PG 3003	390.5	680.5	•	o	•	
PG 3004	451.5	741.5	•			•

	PG ...MC					
	A	B	RA	RB	EF	EDF
PG 3002	319	709		•		
PG 3003	390.5	780.5	•	o	•	
PG 3004	451.5	841.5	•			•

	PG ...F					
	A	B	RA	RB	EF	EDF
PG 3002	309	404		•		
PG 3003	380.5	475.5	•	o	•	
PG 3004	441.5	536.5	•			•

	PG ...FS					
	A	B	RA	RB	EF	EDF
PG 3002	309	499		•		
PG 3003	380.5	570.5	•	o	•	
PG 3004	441.5	631.5	•			•

	PG ...CPC					
	A	B	RA	RB	EF	EDF
PG 3002	499	709		•		
PG 3003	570.5	780.5	•	o	•	
PG 3004	631.5	841.5	•			•

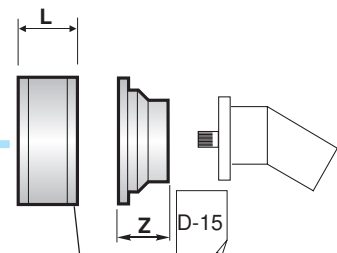
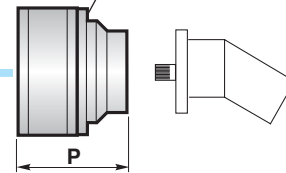
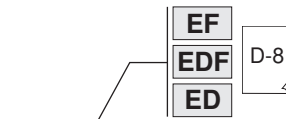
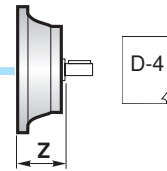
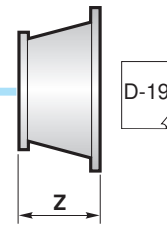
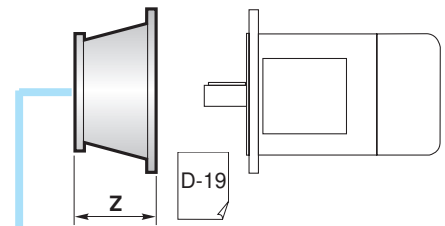

D-2	RA	RB	L
	RA	RB	81 125

!	A+13.5	B+13.5	o
---	--------	--------	---



	PGA ...MS				
	A	B	RA	RB	EF
PGA 3003	407	240	•	o	•
PGA 3004	478.5	240	•	o	•

	PGA ...MC				
	A	B	RA	RB	EF
PGA 3003	407	240	•	o	•
PGA 3004	478.5	240	•	o	•

	PGA ...F				
	A	B	RA	RB	EF
PGA 3003	397	240	•	o	•
PGA 3004	468.5	240	•	o	•

	PGA ...FS				
	A	B	RA	RB	EF
PGA 3003	397	240	•	o	•
PGA 3004	468.5	240	•	o	•

	PGA ...CPC				
	A	B	RA	RB	EF
PGA 3003	585.5	240	•	o	•
PGA 3004	657	240	•	o	•

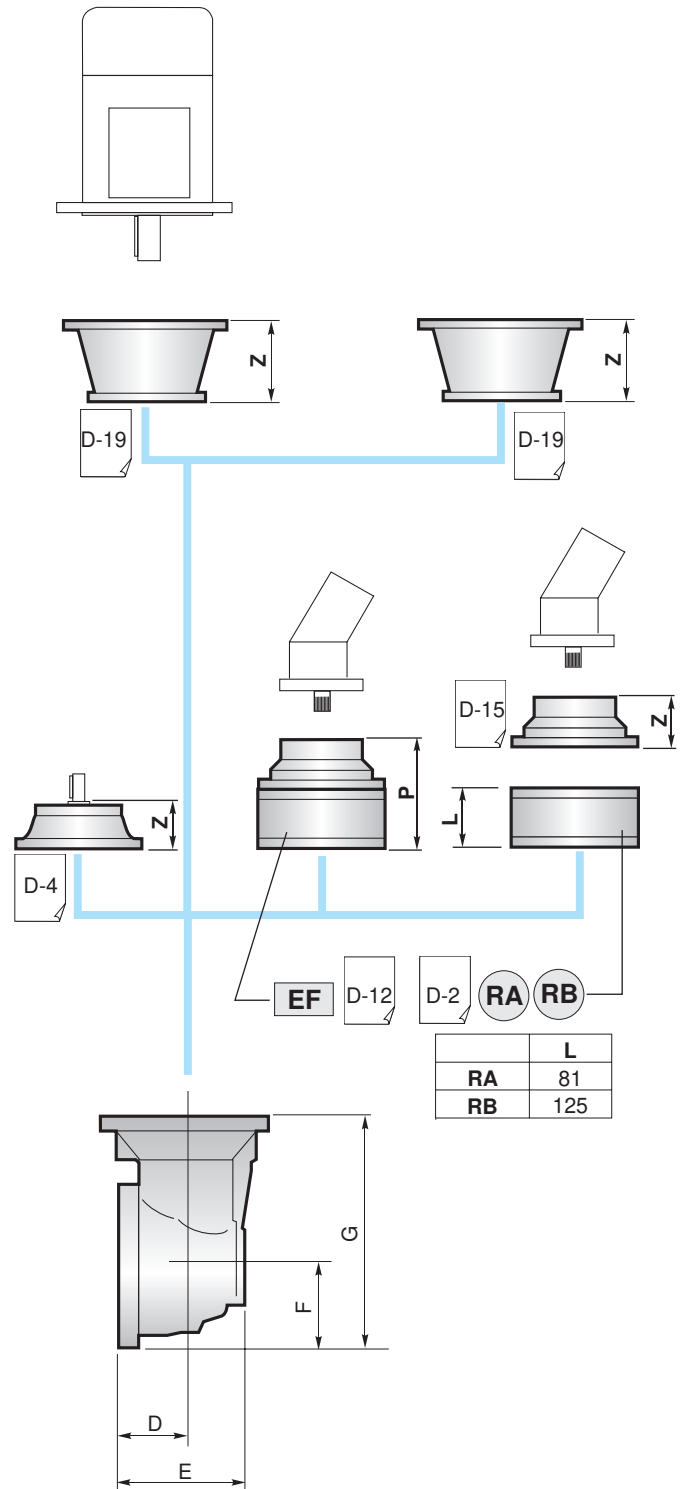

3000

	D	E	F	G
PGA 3003	88	256	235	550
PGA 3004	88	164	140	380

	A+16.5	B	o
--	--------	---	---

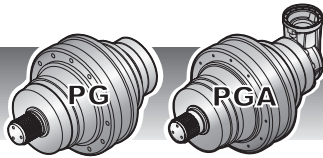

3000

IT EN DE FR ES PT

BS

Boccola scanalata / Splined bushing
Innenverzähnte Buchse / Moyeu cannelé
Casquillo ranurado / Bucha estriada

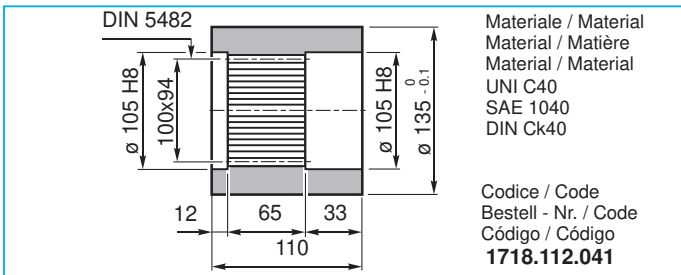

KB

Barra scanalata / Splined rod
Außenverzähnte Welle / Arbre cannelé
Barra ranurada / Barra estriada

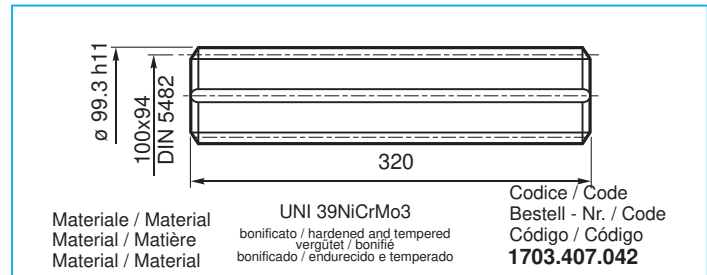

FL

Flangia / Flange
Flansch / Bride
Brida / Flange

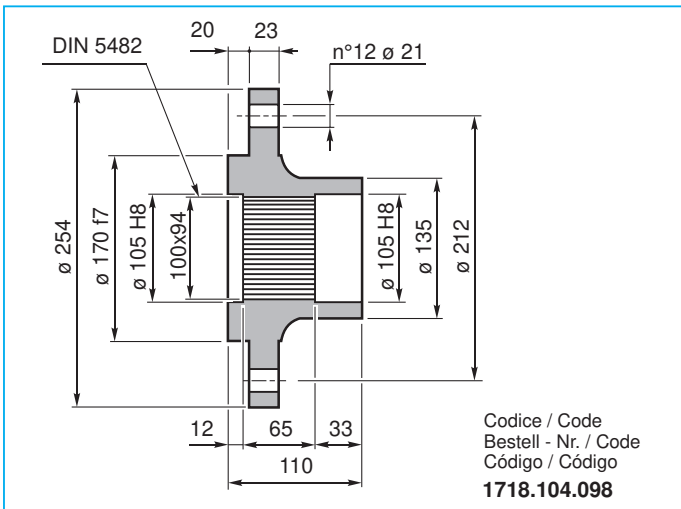

GA

Giunto di attrito / Shrink disc
Schrumpfscheibe / Frette de serrage
Disco de contracción / Disco de contração

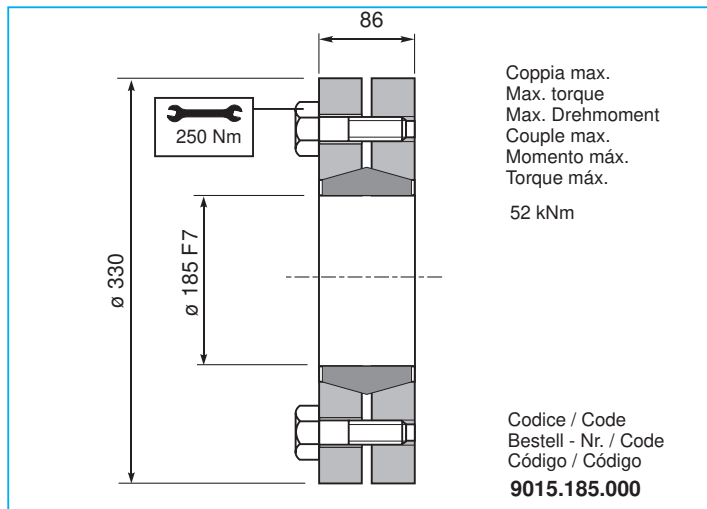

FF

Fondello di arresto / Stop bottom plate
Endscheibe / Bouchon de fermeture
Tapón de detención / Fundo de batente

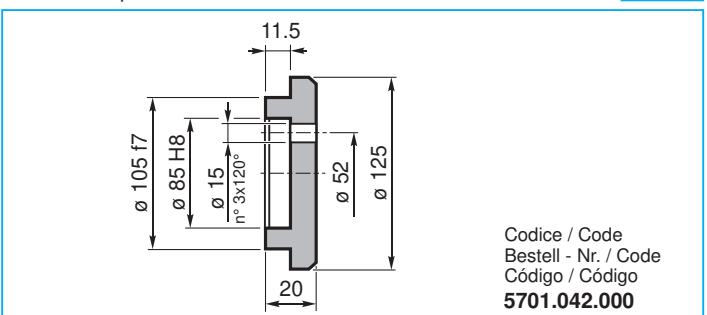

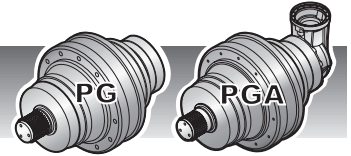

CARICHI RADIALI (Fr)

Nei diagrammi seguenti sono riportati i carichi radiali e i coefficienti K per rapportarli al valore $n_2 \times h$ desiderato.

RADIAL LOADS (Fr)

The following curves show the radial loads and the K factors to obtain the required $n_2 \times h$ value.

RADIALLAST (Fr)

In den nachstehenden Diagrammen ist die Radiallast und der Koeffizient K dargestellt und kann mit dem gewünschten Wert $n_2 \times h$ verglichen werden.

CHARGES RADIALES (Fr)

Dans les diagrammes suivants sont indiqués les charges radiales et les facteurs K de façon à obtenir la valeur $n_2 \times h$ désirée.

CARGAS RADIALES (Fr)

En los siguientes diagramas se indican las cargas radiales y los coeficientes K para obtener el valor requerido $n_2 \times h$.

CARGAS RADIAIS (Fr)

Nos diagramas seguintes são indicadas as cargas radiais e os coeficientes K para obter o valor $n_2 \times h$ desejado.

M - CPC*

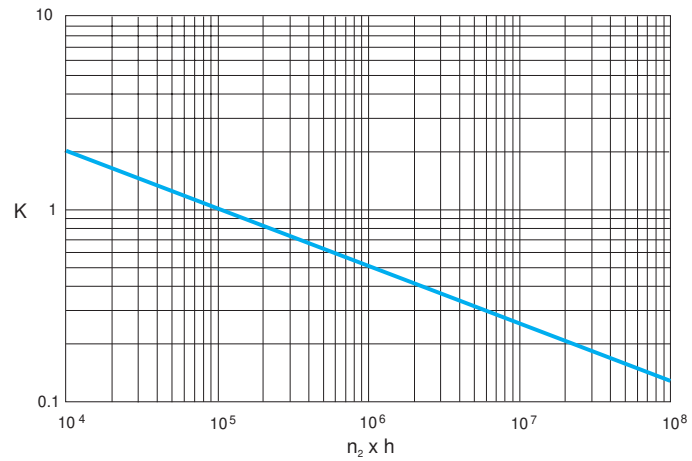
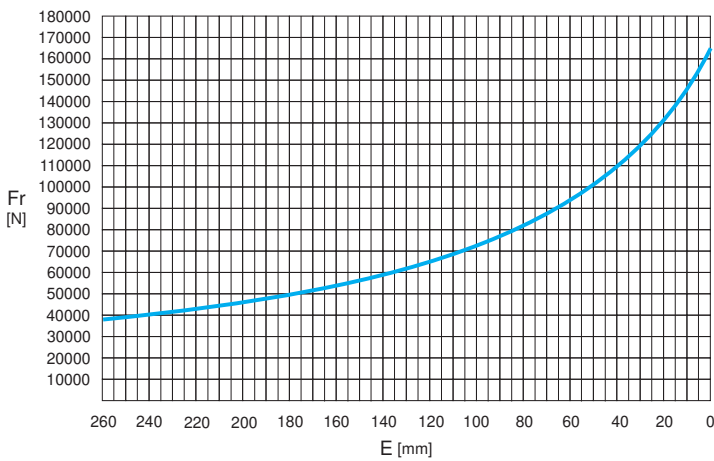

	$n_2 \times h$				
	10^5	10^4	10^6	10^7	10^8
M	Fr				Fr • K
*CPC	Fr • 0.75				Fr • K • 0.75

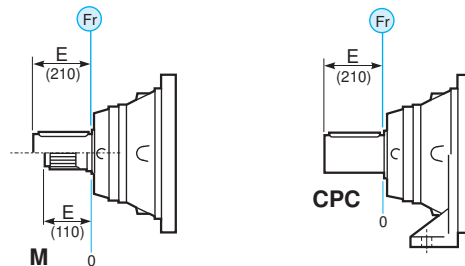

3000

CARICHI ASSIALI (Fa)

I valori dei carichi assiali indicati in tabella sono riferiti alle versioni e alla direzione di applicazione del carico.

AXIAL LOADS (Fa)

The values of the axial loads in the table refer to the output versions and load direction of application.

AXIALLAST (Fa)

Die dargestellten Werte der Axiallast basieren auf der Version und der applizierten Lastrichtung.

CHARGES AXIALES (Fa)

Les valeurs des charges axiales indiquées dans le tableau se réfèrent aux versions et à la direction d'application de la charge.

CARGAS AXIALES (Fa)

Los valores de las cargas axiales indicados en la tabla se refieren a las versiones y a la dirección de aplicación de la carga.

CARGAS AXIAIS (Fa)

Os valores das cargas axiais indicadas na tabela referem-se às versões e à direção de aplicação da carga.

Fa [N]	M	CPC	
		75000	75000
	95000	95000	→

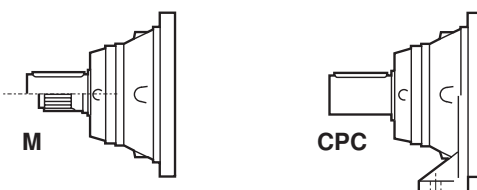



3500

IT EN DE FR ES PT

	i	Mc [kNm]				n _{1max} [min ⁻¹]	Pt [kW]	Kg				
		n ₂ x h	n ₂ x h	n ₂ x h	n ₂ x h			M	P	CPC	F	FS
		10.000	20.000	50.000	100.000							
PG 3501	4.00	42.37	37.50	31.91	28.25	1500	54	193	-	254	157	165
	4.71	36.11	31.96	27.20	24.07							
PG 3502	14.22	41.95	37.11	31.58	27.96	2000	34	243	-	304	207	215
	17.14	36.05	31.92	27.17	24.04							
	20.17	36.11	31.96	27.20	24.07							
	26.35	32.04	28.36	24.12	21.37							
	31.76	24.46	21.65	18.42	16.30							
PG 3503	53.73	41.95	37.11	31.58	27.96	2800	23	259	-	320	223	231
	58.67	41.95	37.11	31.58	27.96							
	64.76	36.05	31.92	27.17	24.04							
	70.71	36.05	31.92	27.17	24.04							
	83.19	36.11	31.96	27.20	24.07							
	88.57	36.05	31.92	27.17	24.04							
	102.86	36.05	31.92	27.17	24.04							
	121.01	36.11	31.96	27.20	24.07							
	136.16	32.04	28.36	24.12	21.37							
	158.12	32.04	28.36	24.12	21.37							
	162.40	28.02	24.80	21.09	18.69							
	191.06	32.04	28.36	24.12	21.37							
	230.29	24.46	21.65	18.42	16.30							
	PG 3504	191.03	41.95	37.11	31.58							
208.59		41.95	37.11	31.58	27.96							
230.26		41.95	37.11	31.58	27.96							
251.43		41.95	37.11	31.58	27.96							
277.55		36.05	31.92	27.17	24.04							
303.06		36.05	31.92	27.17	24.04							
328.53		35.81	31.63	26.92	23.79							
362.67		36.05	31.92	27.17	24.04							
379.59		36.05	31.92	27.17	24.04							
440.82		36.05	31.92	27.17	24.04							
496.00		35.56	31.47	26.75	23.60							
576.00		36.05	31.92	27.17	24.04							
626.65		33.02	29.21	24.85	22.05							
694.29		36.05	31.92	27.17	24.04							
762.48		32.04	28.36	24.12	21.37							
816.81		36.11	31.96	27.20	24.07							
986.97		33.02	29.21	24.85	22.05							
1067.29		32.04	28.36	24.12	21.37							
1289.65		32.04	28.36	24.12	21.37							

I rapporti contrassegnati possono essere forniti solo in versione **M**; per ulteriori informazioni contattare il servizio tecnico COMER.
Ratios marked can only be supplied in version **M**; for more information please contact COMER technical service.



	i	Mc [kNm]				n _{1max} [min ⁻¹]	Pt [kW]	Kg				
		n ₂ x h	n ₂ x h	n ₂ x h	n ₂ x h			M	P	CPC	F	FS
		10.000	20.000	50.000	100.000							
PGA 3502	12.29	27.63	24.55	18.65	15.16	2000	34	285	-	346	248	256
	14.45	32.10	27.51	20.90	16.98							
	18.67	17.69	16.65	15.36	13.80							
	21.96	20.52	19.31	17.82	15.46							
PGA 3503	43.68	41.95	37.11	31.58	27.96	2800	23	342	-	403	305	313
	52.65	36.05	31.92	27.17	24.04							
	66.37	41.95	37.11	31.58	27.96							
	80.00	36.05	31.92	27.17	24.04							
	94.12	36.11	31.96	27.20	24.07							
	122.98	32.04	28.36	24.12	21.37							
PGA 3504	185.61	41.95	37.11	31.58	27.96	2'800	17	299	-	360	263	271
	202.67	41.95	37.11	31.58	27.96							
	223.72	36.05	31.92	27.17	24.04							
	244.29	36.05	31.92	27.17	24.04							
	298.64	36.11	31.96	27.20	24.07							
	319.41	34.61	32.28	29.44	27.46							
	352.59	36.05	31.92	27.17	24.04							
	385.00	36.05	31.92	27.17	24.04							
	414.81	36.11	31.96	27.20	24.07							
	464.59	31.64	28.03	23.84	21.15							
	546.58	36.11	31.96	27.20	24.07							
	591.84	32.04	28.36	24.12	21.37							
	658.82	36.11	31.96	27.20	24.07							
	741.30	32.04	28.36	24.12	21.37							
	884.18	28.02	24.80	21.09	18.69							
	1040.21	32.04	28.36	24.12	21.37							
1253.82	24.46	21.65	18.42	16.30								

3500

I rapporti contrassegnati possono essere forniti solo in versione **M**; per ulteriori informazioni contattare il servizio tecnico COMER.
Ratios marked can only be supplied in version **M**; for more information please contact COMER technical service.



(n₂ x h = 20.000)
M_{max} = M_c x 1.65

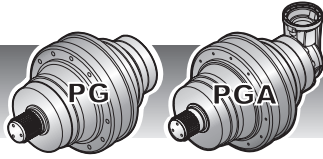

3500

IT EN DE FR ES PT

MS

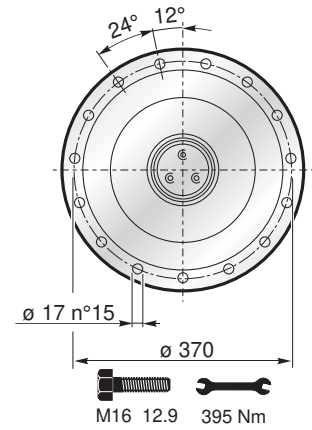
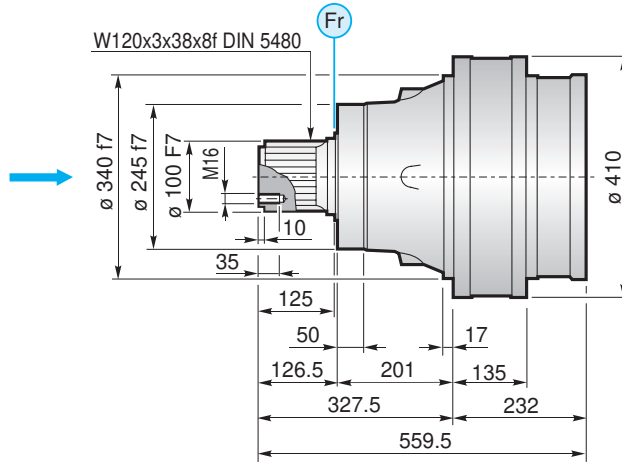
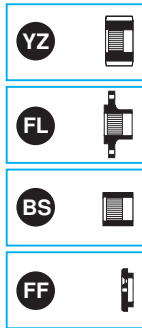

MC

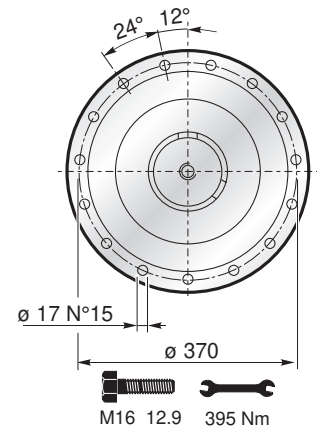
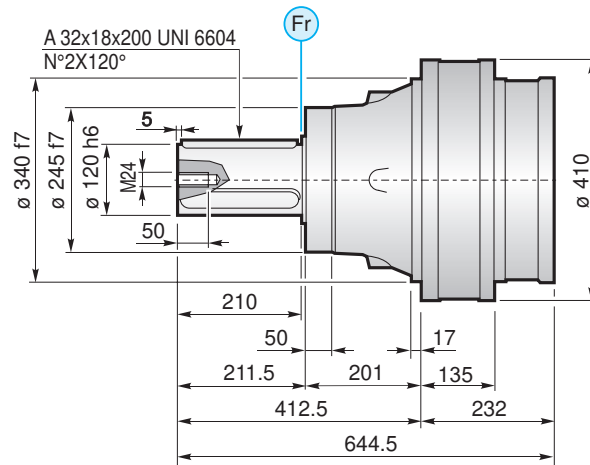

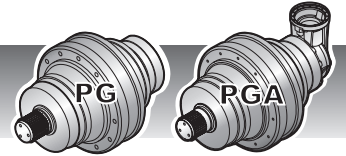

F

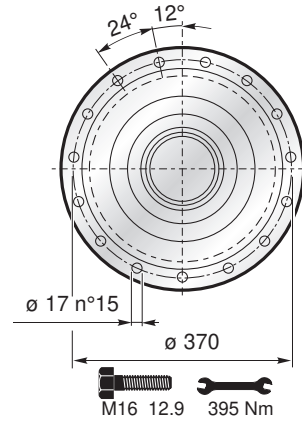
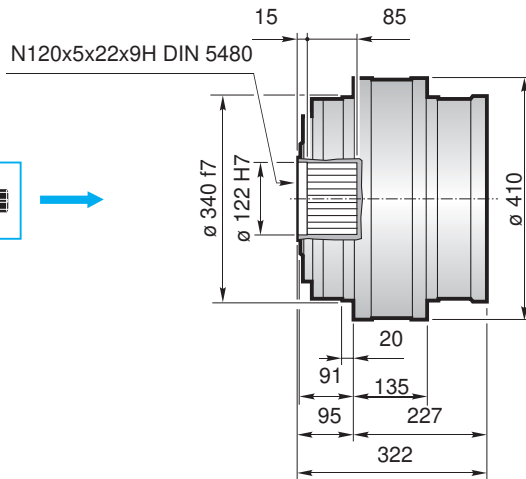

FS

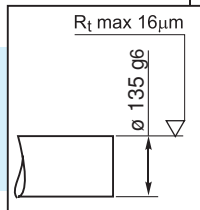
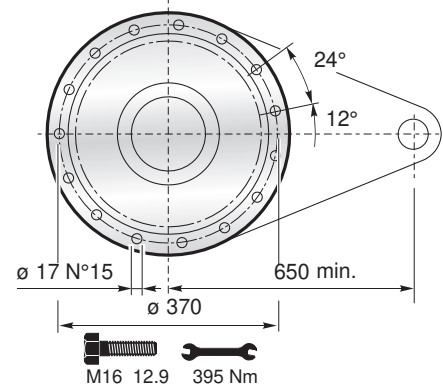
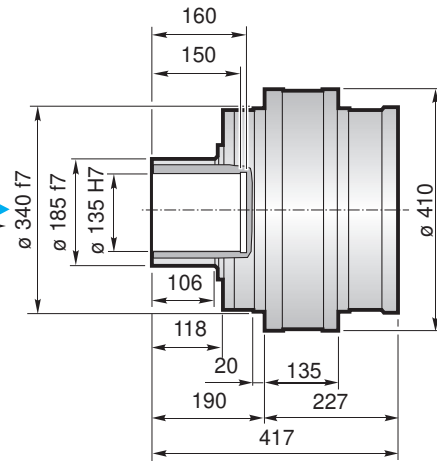

$M_{max} = 52 \text{ kNm}$

La coppia massima indicata è valida solo con calettatori forniti da Planetary Drives
 The maximum torque indicated is valid only with shrink discs supplied by Planetary Drives
 Das dargestellte, maximale Drehmoment gilt nur mit von Planetary Drives gelieferter Schrumpfscheibe
 Le couple maximal indiqué n'est valable qu'avec les frettes de serrage fournis par Planetary Drives
 El momento máximo indicado sólo es válido con discos de contracción suministrados por Planetary Drives
 O torque máximo indicado é válido exclusivamente com discos de contração fornecidos pela Planetary Drives

3500

CPC

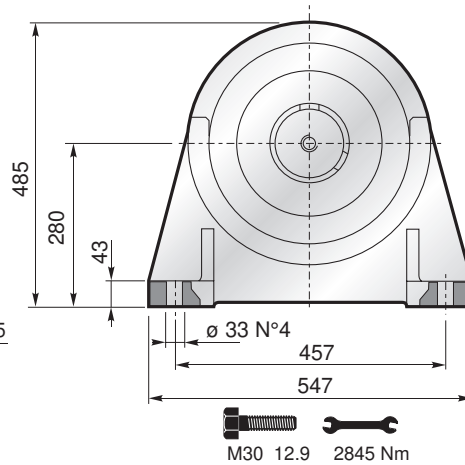
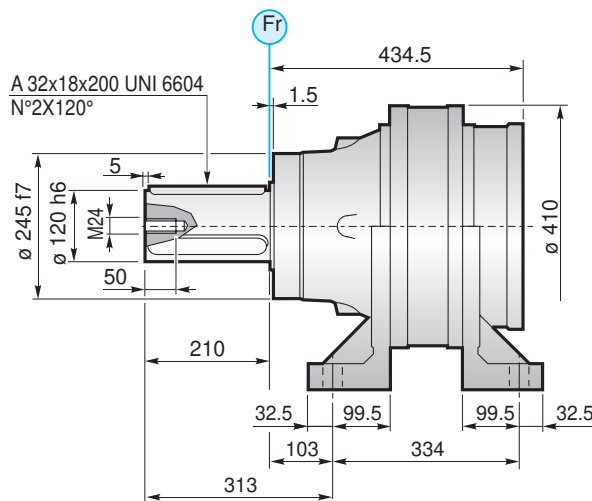

FL YZ BS FF KB GA → B-90



3500

IT EN DE FR ES PT

PG	...MS					
	A	B	RA	RB	EF	EDF
PG 3501	232	559.5				
PG 3502	319	646.5		•		
PG 3503	390.5	718	•	o	•	
PG 3504	451.5	779	•			•

PG	...MC					
	A	B	RA	RB	EF	EDF
PG 3501	232	644.5				
PG 3502	319	731.5		•		
PG 3503	390.5	803	•	o	•	
PG 3504	451.5	864	•			•

PG	...F					
	A	B	RA	RB	EF	EDF
PG 3501	227	322				
PG 3502	314	409		•		
PG 3503	385.5	480.5	•	o	•	
PG 3504	446.5	541.5	•			•

PG	...FS					
	A	B	RA	RB	EF	EDF
PG 3501	227	417				
PG 3502	314	504		•		
PG 3503	385.5	575.5	•	o	•	
PG 3504	446.5	636.5	•			•

PG	...CPC					
	A	B	RA	RB	EF	EDF
PG 3501	434.5	644.5				
PG 3502	521.5	731.5		•		
PG 3503	593	803	•	o	•	
PG 3504	654	864	•			•

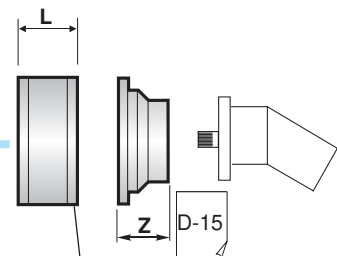
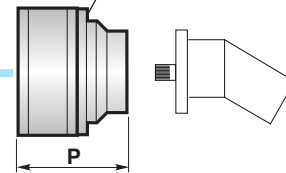
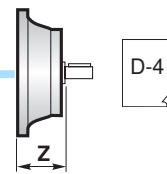
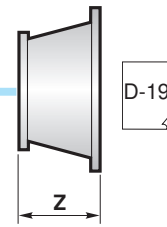
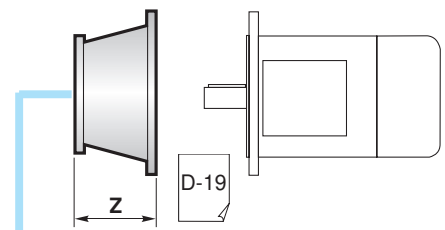

D-2	RA	RB	L
	RA	RB	81
	RA	RB	125

⚠	A+13.5	B+13.5	o
---	--------	--------	---



	PGA ...MS		RA	RB	EF
	A	B			
PGA 3502	297	315		•	
PGA 3503	454	240	•	o	•
PGA 3504	492	240	•		•

	PGA ...MC		RA	RB	EF
	A	B			
PGA 3502	297	315		•	
PGA 3503	454	240	•	o	•
PGA 3504	492	240	•		•

	PGA ...F		RA	RB	EF
	A	B			
PGA 3502	287	315		•	
PGA 3503	444	240	•	o	•
PGA 3504	482	240	•		•

	PGA ...FS		RA	RB	EF
	A	B			
PGA 3502	287	315		•	
PGA 3503	444	240	•	o	•
PGA 3504	482	240	•		•

	PGA ...CPC		RA	RB	EF
	A	B			
PGA 3502	499.5	315		•	
PGA 3503	656.5	240	•	o	•
PGA 3504	694.5	240	•		•

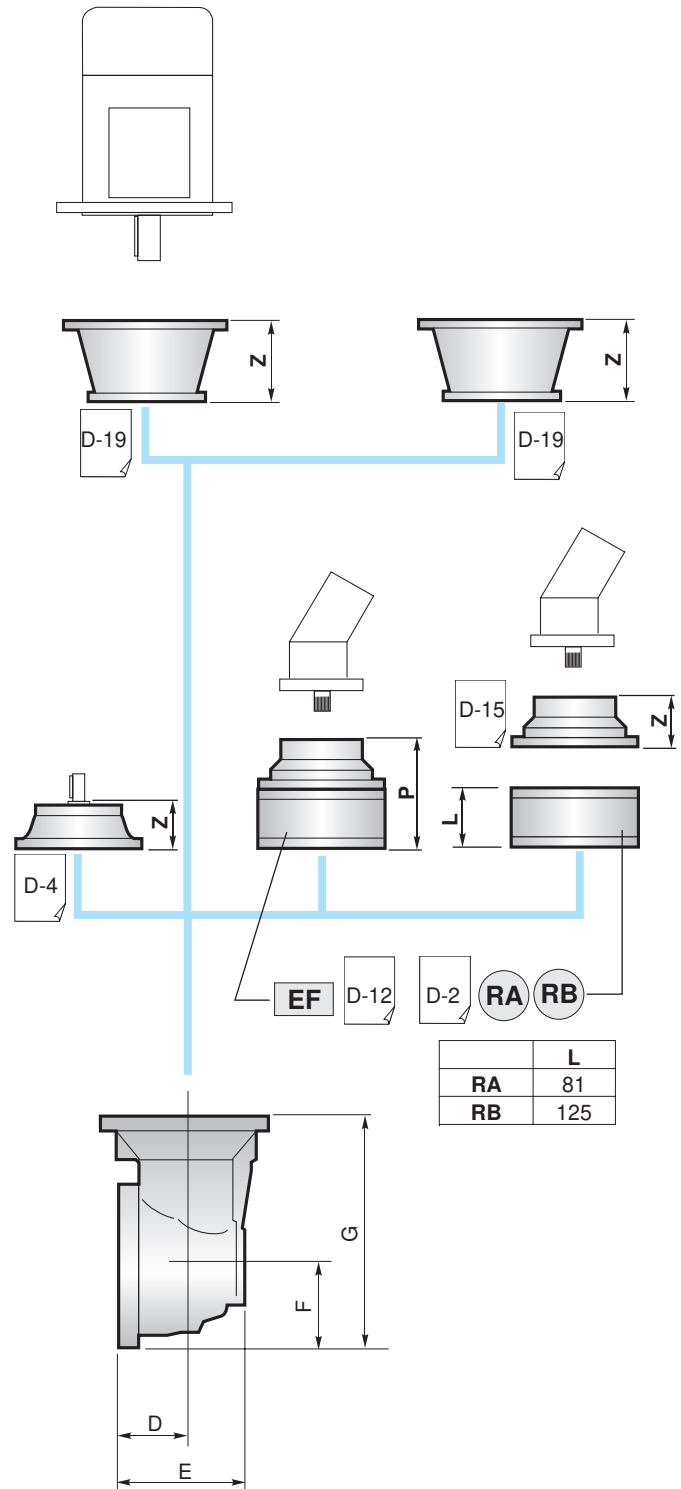

	D	E	F	G
PGA 3502	88	256	235	550
PGA 3503	88	256	235	550
PGA 3504	88	164	140	380

	A	B+16.5	o
--	---	--------	---

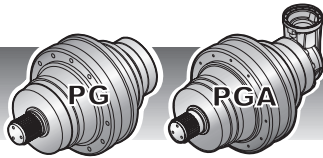

3500

IT EN DE FR ES PT

BS

Boccola scanalata / Splined bushing
Innenverzahnte Buchse / Moyeu cannelé
Casquillo ranurado / Bucha estriada

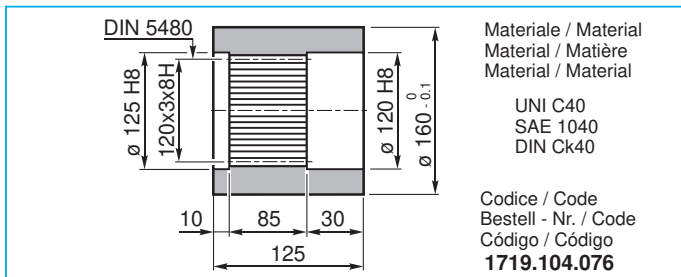

KB

Barra scanalata / Splined rod
Außenverzahnte Welle / Arbre cannelé
Barra ranurada / Barra estriada

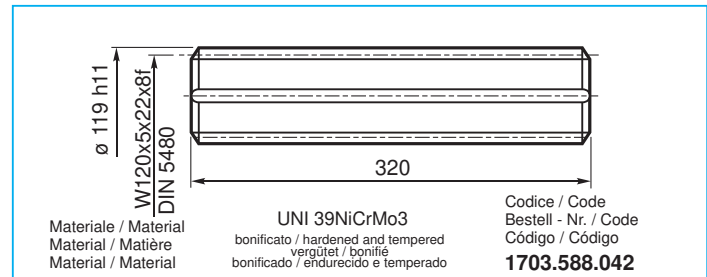

FL

Flangia / Flange
Flansch / Bride
Brida / Flange

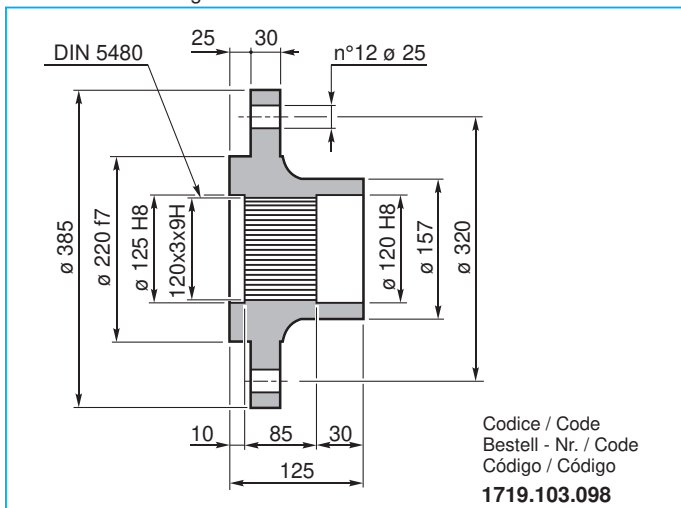

GA

Giunto di attrito / Shrink disc
Schrumpfscheibe / Frette de serrage
Disco de contracción / Disco de contração

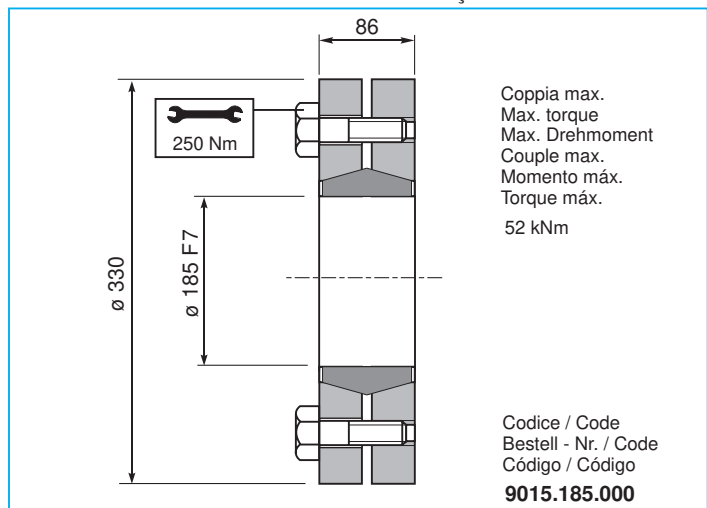

FF

Fondello di arresto / Stop bottom plate
Endscheibe / Bouchon de fermeture
Tapón de detención / Fundo de batente

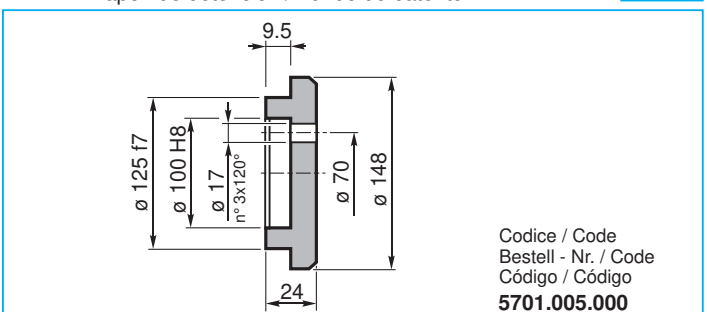

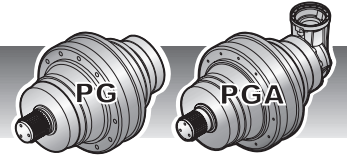

CARICHI RADIALI (Fr)

Nei diagrammi seguenti sono riportati i carichi radiali e i coefficienti K per rapportarli al valore $n_2 \times h$ desiderato.

RADIAL LOADS (Fr)

The following curves show the radial loads and the K factors to obtain the required $n_2 \times h$ value.

RADIALLAST (Fr)

In den nachstehenden Diagrammen ist die Radiallast und der Koeffizient K dargestellt und kann mit dem gewünschten Wert $n_2 \times h$ verglichen werden.

CHARGES RADIALES (Fr)

Dans les diagrammes suivants sont indiqués les charges radiales et les facteurs K de façon à obtenir la valeur $n_2 \times h$ désirée.

CARGAS RADIALES (Fr)

En los siguientes diagramas se indican las cargas radiales y los coeficientes K para obtener el valor requerido $n_2 \times h$.

CARGAS RADIAIS (Fr)

Nos diagramas seguintes são indicadas as cargas radiais e os coeficientes K para obter o valor $n_2 \times h$ desejado.

M - CPC*

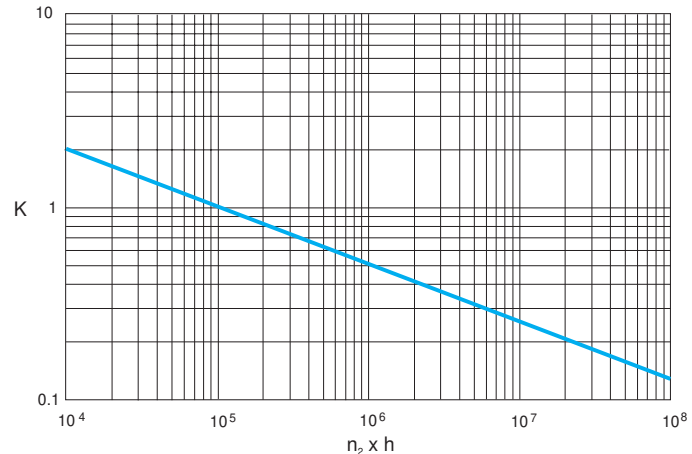
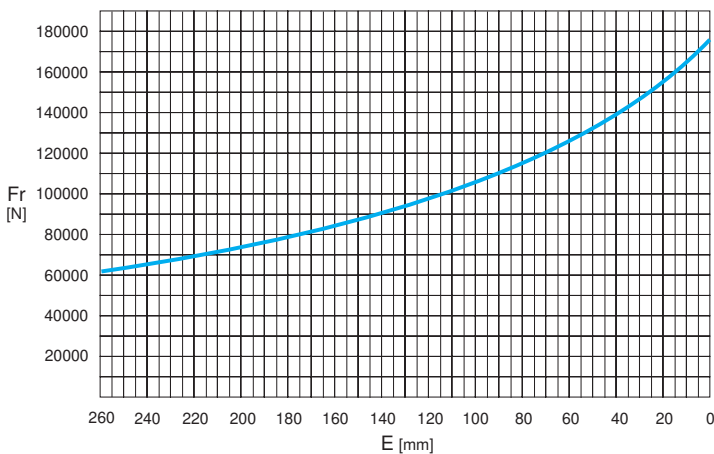

	$n_2 \times h$				
	10^5	10^4	10^6	10^7	10^8
M	Fr		Fr · K		
*CPC	Fr · 0.75		Fr · K · 0.75		

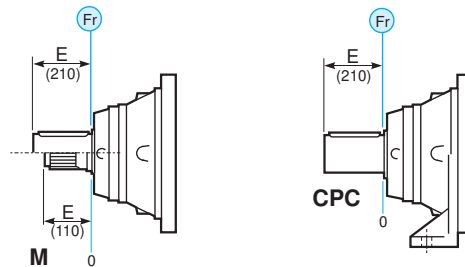

3500

CARICHI ASSIALI (Fa)

I valori dei carichi assiali indicati in tabella sono riferiti alle versioni e alla direzione di applicazione del carico.

AXIAL LOADS (Fa)

The values of the axial loads in the table refer to the output versions and load direction of application.

AXIALLAST (Fa)

Die dargestellten Werte der Axiallast basieren auf der Version und der applizierten Lastrichtung.

CHARGES AXIALES (Fa)

Les valeurs des charges axiales indiquées dans le tableau se réfèrent aux versions et à la direction d'application de la charge.

CARGAS AXIALES (Fa)

Los valores de las cargas axiales indicados en la tabla se refieren a las versiones y a la dirección de aplicación de la carga.

CARGAS AXIAIS (Fa)

Os valores das cargas axiais indicadas na tabela referem-se às versões e à direção de aplicação da carga.

Fa [N]	M	CPC	
		80000	80000
	100000	100000	→

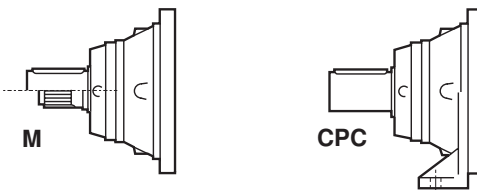



5000

IT EN DE FR ES PT

	i	Mc [kNm]				n _{1max} [min ⁻¹]	Pt [kW]	Kg				
		n ₂ x h	n ₂ x h	n ₂ x h	n ₂ x h			M	P	CPC	F	FS
		10.000	20.000	50.000	100.000							
PG 5001	3.95	68.69	60.80	51.74	45.80	1200	60	314	-	418	256	269
	5.06	50.28	44.50	37.87	33.52							
	6.00	40.11	35.50	30.21	26.74							
PG 5002	14.06	61.30	54.25	46.15	40.85	2000	38	373	-	477	315	328
	16.95	53.41	47.27	40.22	35.62							
	21.70	50.28	44.50	37.87	33.52							
	25.71	40.11	35.50	30.21	26.74							
	28.35	50.07	44.32	37.71	33.39							
	33.60	40.11	35.50	30.21	26.74							
	40.50	40.11	35.50	30.21	26.74							
PG 5003	53.12	47.97	42.49	36.17	32.01	2800	25	389	-	493	331	344
	64.03	53.41	47.27	40.22	35.62							
	74.25	50.28	44.50	37.87	33.52							
	81.96	50.28	44.50	37.87	33.52							
	89.50	50.28	44.50	37.87	33.52							
	107.10	50.07	44.32	37.71	33.39							
	116.94	50.07	44.32	37.71	33.39							
	130.18	44.82	39.71	33.76	29.96							
	146.48	50.07	44.32	37.71	33.39							
	154.29	40.11	35.50	30.21	26.74							
	170.10	50.07	44.32	37.71	33.39							
	205.54	43.72	38.68	32.90	29.20							
	243.60	40.11	35.50	30.21	26.74							
	293.63	40.11	35.50	30.21	26.74							
PG 5004	318.21	50.28	44.50	37.87	33.52	2800	20	397	-	501	339	352
	351.28	50.28	44.50	37.87	33.52							
	383.56	50.28	44.50	37.87	33.52							
	415.80	50.07	44.32	37.71	33.39							
	459.00	50.07	44.32	37.71	33.39							
	520.80	50.07	44.32	37.71	33.39							
	557.91	44.82	39.71	33.76	29.96							
	599.76	50.07	44.32	37.71	33.39							
	627.75	50.28	44.50	37.87	33.52							
	722.93	48.50	42.92	36.48	32.19							
	789.37	50.07	44.32	37.71	33.39							
	878.71	44.82	39.71	33.76	29.96							
	952.56	50.07	44.32	37.71	33.39							
	1044.00	40.11	35.50	30.21	26.74							
	1148.18	50.07	44.32	37.71	33.39							
	1258.39	40.11	35.50	30.21	26.74							
	1387.38	43.72	38.68	32.90	29.20							
	1644.30	40.11	35.50	30.21	26.74							
1981.97	40.11	35.50	30.21	26.74								



	i	Mc [kNm]				n _{1max} [min ⁻¹]	Pt [kW]	Kg				
		n ₂ x h	n ₂ x h	n ₂ x h	n ₂ x h			M	P	CPC	F	FS
		10.000	20.000	50.000	100.000							
PGA 5002	12.15	27.34	24.35	18.51	15.04	2000	38	364	-	468	306	319
	15.55	34.34	28.95	22.00	17.87							
	18.43	40.11	32.60	24.78	20.13							
	23.63	21.94	20.64	19.05	16.27							
	28.00	25.61	24.10	22.24	18.33							
PGA 5003	62.18	26.28	23.93	19.16	15.56	2800	25	410	-	514	293	306
	76.50	31.44	28.63	22.15	17.99							
	97.94	38.93	34.65	26.33	21.39							
	118.05	38.08	33.69	28.67	24.38							
	139.91	40.11	35.50	30.21	26.74							
	220.50	25.89	24.15	22.03	20.55							
PGA 5004	241.51	51.01	45.19	38.50	34.04	2800	20	429	-	533	371	384
	289.01	40.85	36.16	30.77	27.25							
	309.17	50.28	44.50	37.87	33.52							
	366.43	40.11	35.50	30.21	26.74							
	395.26	40.85	36.16	30.77	27.25							
	459.01	40.85	36.16	30.77	27.25							
	497.35	40.85	36.16	30.77	27.25							
	554.64	35.67	31.56	26.84	23.82							
	587.62	50.07	44.32	37.71	33.39							
	636.69	50.07	44.32	37.71	33.39							
	708.75	44.82	39.71	33.76	29.96							
	797.48	50.07	44.32	37.71	33.39							
	855.85	38.08	33.69	28.67	25.39							
	945.16	40.11	35.50	30.21	26.74							
	1139.25	40.11	35.50	30.21	26.74							
1326.27	40.11	35.50	30.21	26.74								

5000



(n₂ x h = 20.000)

$$M_{\max} = M_C \times 2$$

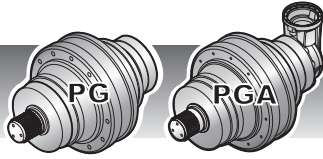

5000

IT EN DE FR ES PT

MS

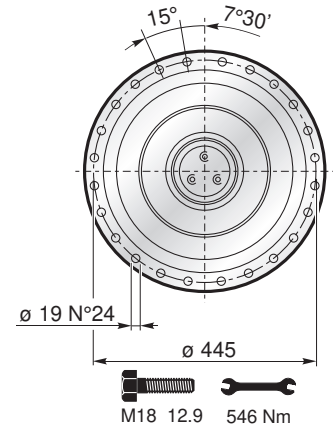
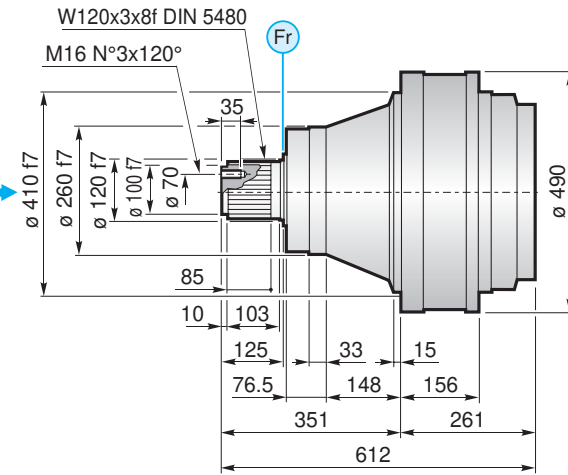
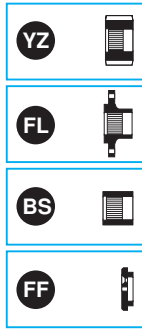

MC

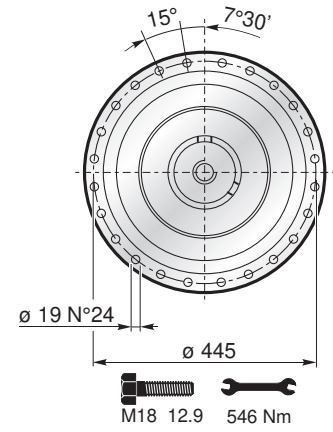
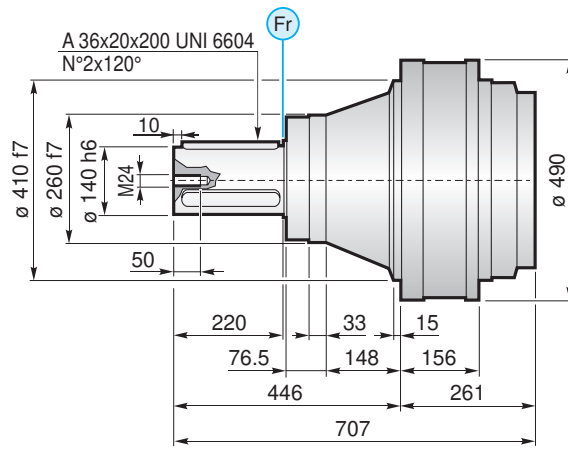

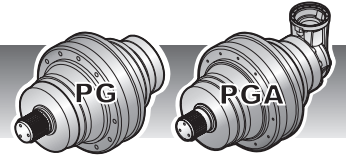

F

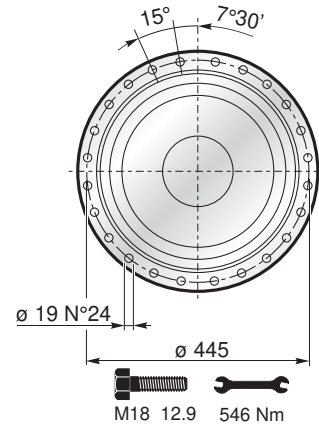
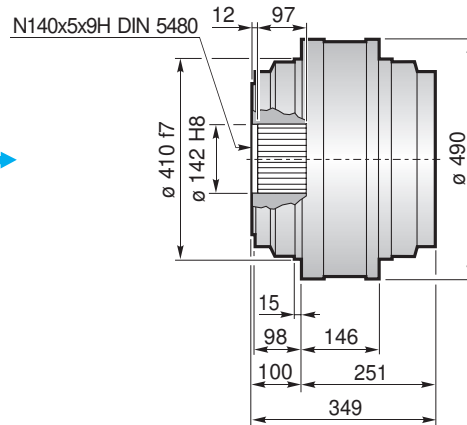
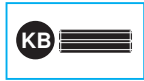

FS

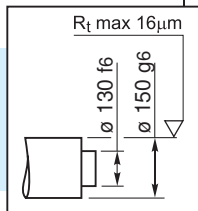
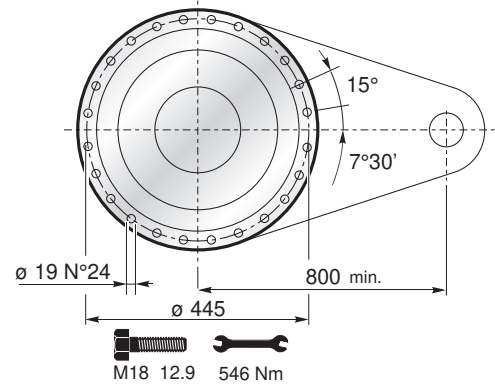
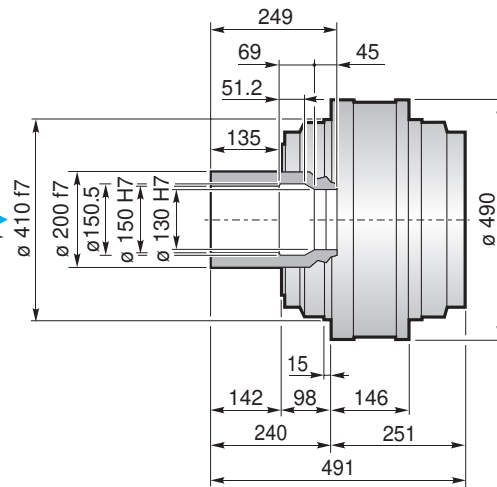

$M_{max} = 92.5 \text{ kNm}$

La coppia massima indicata è valida solo con calettatori forniti da Planetary Drives
 The maximum torque indicated is valid only with shrink discs supplied by Planetary Drives
 Das dargestellte, maximale Drehmoment gilt nur mit von Planetary Drives gelieferter Schrumpfscheibe
 Le couple maximal indiqué n'est valable qu'avec les frettes de serrage fournis par Planetary Drives
 El momento máximo indicado sólo es válido con discos de contracción suministrados por Planetary Drives
 O torque máximo indicado é válido exclusivamente com discos de contração fornecidos pela Planetary Drives

CPC

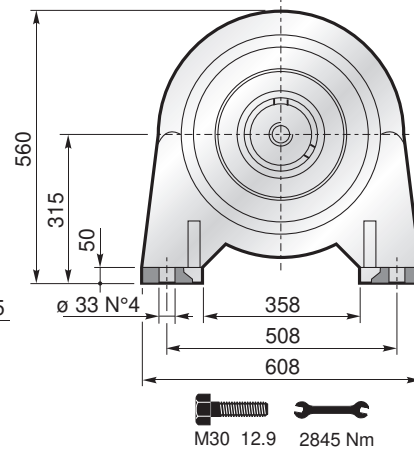
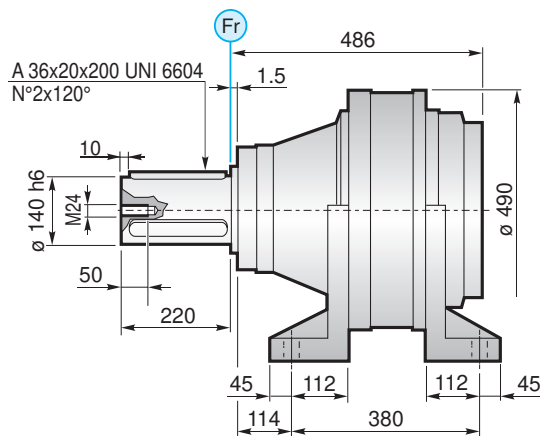

FL YZ BS FF KB GA → B-98



5000

IT EN DE FR ES PT

PG	...MS					
	A	B	RA	RB	EF	EDF
PG 5001	261	612				
PG 5002	368	719		•		
PG 5003	439.5	790.5	•	o	•	
PG 5004	500.5	851.5	•			•

PG	...MC					
	A	B	RA	RB	EF	EDF
PG 5001	261	707				
PG 5002	368	814		•		
PG 5003	439.5	885.5	•	o	•	
PG 5004	500.5	946.5	•			•

PG	...F					
	A	B	RA	RB	EF	EDF
PG 5001	251	349				
PG 5002	358	456		•		
PG 5003	429.5	527.5	•	o	•	
PG 5004	490.5	588.5	•			•

PG	...FS					
	A	B	RA	RB	EF	EDF
PG 5001	251	491				
PG 5002	358	598		•		
PG 5003	429.5	669.5	•	o	•	
PG 5004	490.5	730.5	•			•

PG	...CPC					
	A	B	RA	RB	EF	EDF
PG 5001	486	706				
PG 5002	593	813		•		
PG 5003	664.5	884.5	•	o	•	
PG 5004	725.5	945.5	•			•

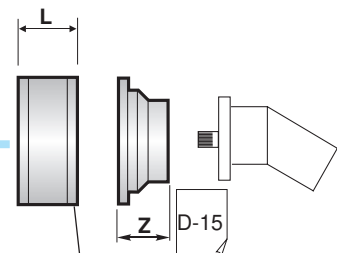
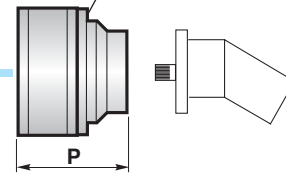
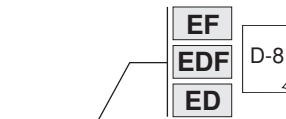
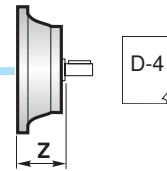
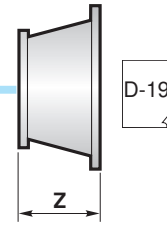
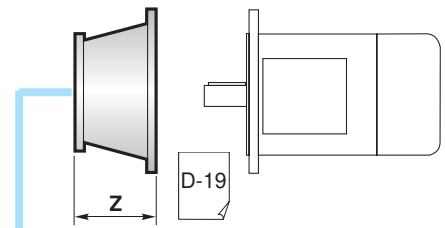

D-2	RA	RB	L
	RA	RB	81
	RA	RB	125

!	A+13.5	B+13.5	o
---	--------	--------	---



	PGA ...MS				
	A	B	RA	RB	EF
PGA 5002	442	315		•	
PGA 5003	456	240	•	o	•
PGA 5004	541	240	•		•

	PGA ...MC				
	A	B	RA	RB	EF
PGA 5002	442	315		•	
PGA 5003	456	240	•	o	•
PGA 5004	541	240	•		•

	PGA ...F				
	A	B	RA	RB	EF
PGA 5002	432	315		•	
PGA 5003	446	240	•	o	•
PGA 5004	531	240	•		•

	PGA ...FS				
	A	B	RA	RB	EF
PGA 5002	432	315		•	
PGA 5003	446	240	•	o	•
PGA 5004	531	240	•		•

	PGA ...CPC				
	A	B	RA	RB	EF
PGA 5002	667	315		•	
PGA 5003	681	240	•	o	•
PGA 5004	766	240	•		•

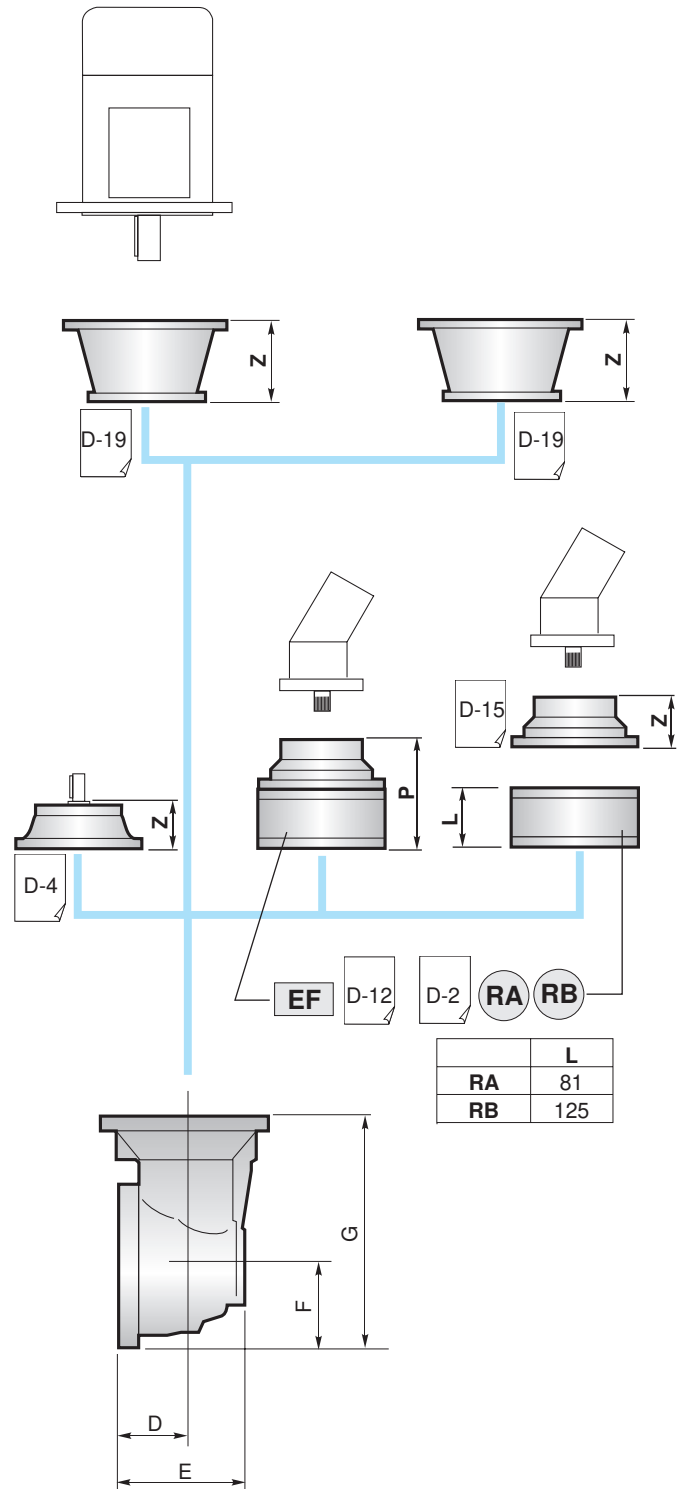

5000

	D	E	F	G
PGA 5002	88	256	235	550
PGA 5003	88	164	140	380
PGA 5004	88	164	140	380

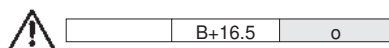

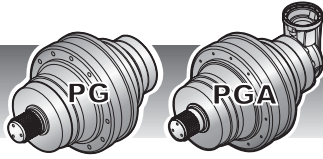

5000

IT EN DE FR ES PT

BS Boccola scanalata / Splined bushing
Innenverzahnte Buchse / Moyeu cannelé
Casquillo ranurado / Bucha estriada

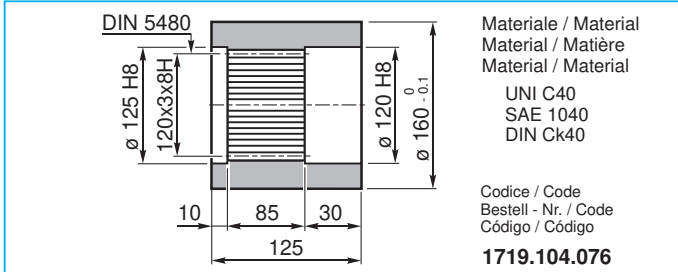

KB Barra scanalata / Splined rod
Außenverzahnte Welle / Arbre cannelé
Barra ranurada / Barra estriada

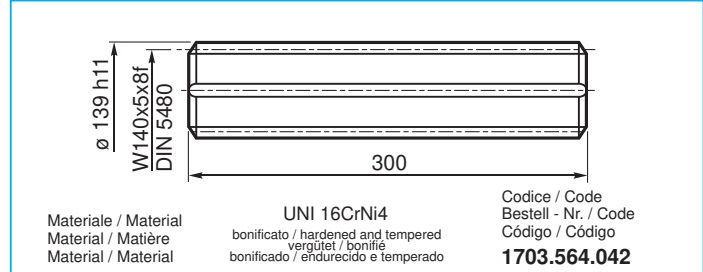

FL Flangia / Flange
Flansch / Bride
Brida / Flange

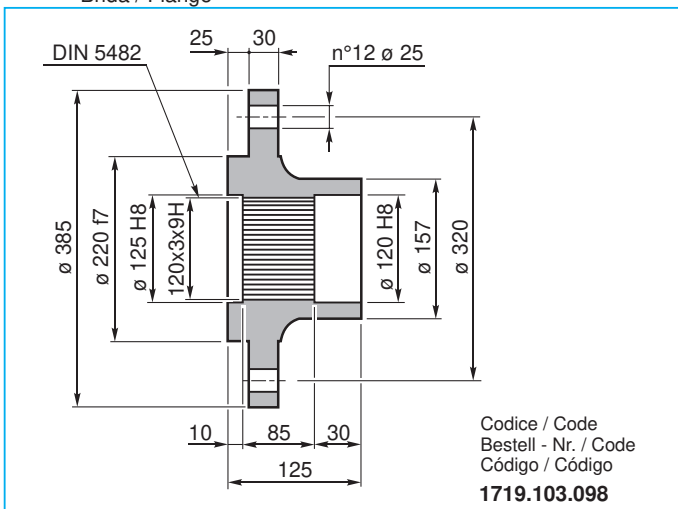

GA Giunto di attrito / Shrink disc
Schrumpfscheibe / Frette de serrage
Disco de contracción / Disco de contração

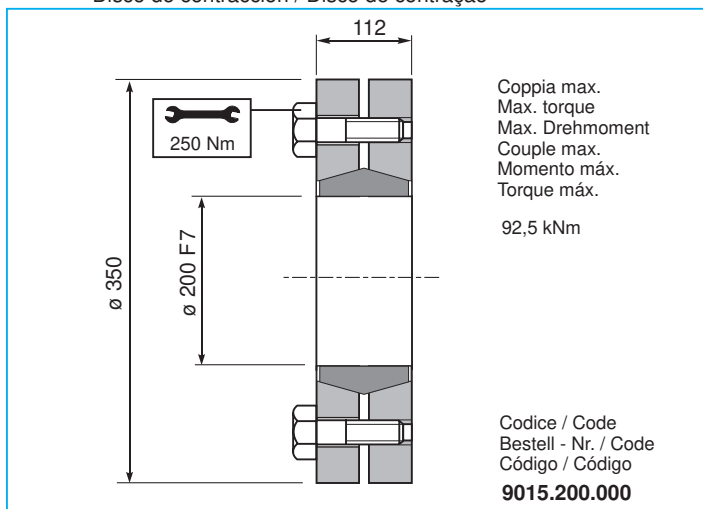

FF Fondello di arresto / Stop bottom plate
Endscheibe / Bouchon de fermeture
Tapón de detención / Fundo de batente

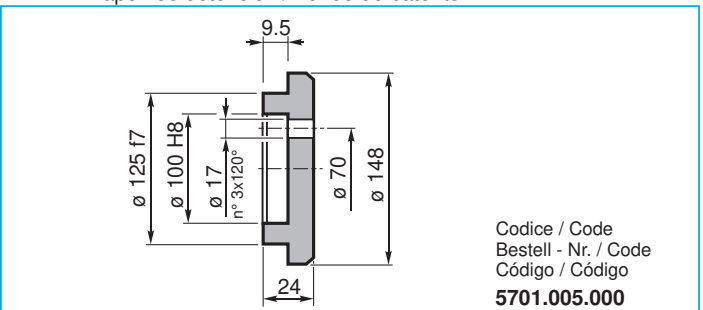

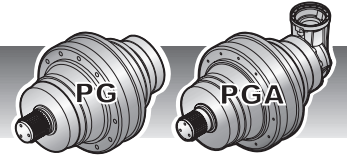

CARICHI RADIALI (Fr)

Nei diagrammi seguenti sono riportati i carichi radiali e i coefficienti K per rapportarli al valore $n_2 \times h$ desiderato.

RADIAL LOADS (Fr)

The following curves show the radial loads and the K factors to obtain the required $n_2 \times h$ value.

RADIALLAST (Fr)

In den nachstehenden Diagrammen ist die Radiallast und der Koeffizient K dargestellt und kann mit dem gewünschten Wert $n_2 \times h$ verglichen werden.

CHARGES RADIALES (Fr)

Dans les diagrammes suivants sont indiqués les charges radiales et les facteurs K de façon à obtenir la valeur $n_2 \times h$ désirée.

CARGAS RADIALES (Fr)

En los siguientes diagramas se indican las cargas radiales y los coeficientes K para obtener el valor requerido $n_2 \times h$.

CARGAS RADIAIS (Fr)

Nos diagramas seguintes são indicadas as cargas radiais e os coeficientes K para obter o valor $n_2 \times h$ desejado.

M - CPC*

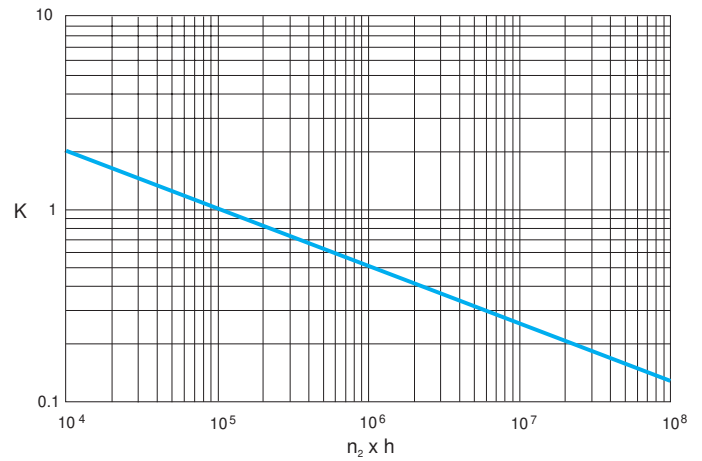
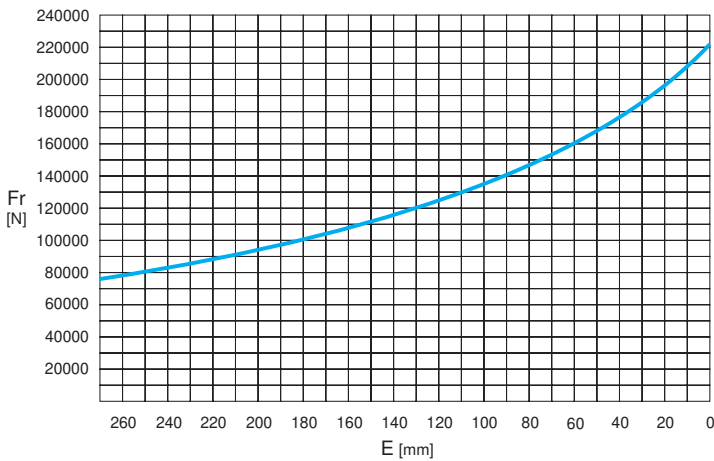

	$n_2 \times h$				
	10^5	10^4	10^6	10^7	10^8
M	Fr				Fr • K
*CPC	Fr • 0.75				Fr • K • 0.75

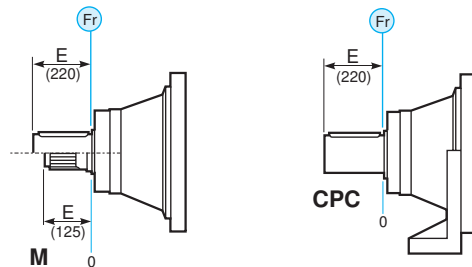

CARICHI ASSIALI (Fa)

I valori dei carichi assiali indicati in tabella sono riferiti alle versioni e alla direzione di applicazione del carico.

AXIAL LOADS (Fa)

The values of the axial loads in the table refer to the output versions and load direction of application.

AXIALLAST (Fa)

Die dargestellten Werte der Axiallast basieren auf der Version und der applizierten Lastrichtung.

CHARGES AXIALES (Fa)

Les valeurs des charges axiales indiquées dans le tableau se réfèrent aux versions et à la direction d'application de la charge.

CARGAS AXIALES (Fa)

Los valores de las cargas axiales indicados en la tabla se refieren a las versiones y a la dirección de aplicación de la carga.

CARGAS AXIAIS (Fa)

Os valores das cargas axiais indicadas na tabela referem-se às versões e à direção de aplicação da carga.

Fa [N]	M	CPC	
	80000	80000	←
120000	120000	→	

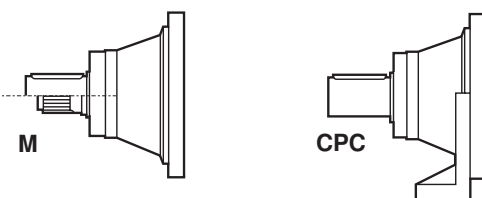



6500

IT EN DE FR ES PT

	i	Mc [kNm]				n _{1max} [min ⁻¹]	Pt [kW]	Kg				
		n ₂ x h	n ₂ x h	n ₂ x h	n ₂ x h			M	P	CPC	F	FS
		10.000	20.000	50.000	100.000							
PG 6501	3.83	78.31	69.31	58.98	52.21	1000	60	334	-	438	276	290
PG 6502	15.30	78.31	69.31	58.98	52.21	1500	50	450	-	554	392	406
	19.90	78.31	69.31	58.98	52.21							
	23.91	60.75	53.78	45.77	40.50							
PG 6503	56.12	70.68	62.57	53.21	47.15	2500	35	477	-	581	419	433
	67.78	64.53	57.14	48.58	43.05							
	72.95	78.31	69.31	58.98	52.21							
	88.11	78.31	69.31	58.98	52.21							
	99.48	70.37	62.30	53.00	46.92							
	115.39	59.53	52.67	44.81	39.72							
	138.70	60.75	53.78	45.77	40.50							
	167.39	56.01	49.57	42.23	37.34							
PG 6504	211.99	70.68	62.57	53.21	47.15	2800	25	489	-	593	431	445
	231.48	70.68	62.57	53.21	47.15							
	275.59	78.31	69.31	58.98	52.21							
	300.92	78.31	69.31	58.98	52.21							
	332.86	78.31	69.31	58.98	52.21							
	363.45	78.31	69.31	58.98	52.21							
	410.35	70.37	62.30	53.00	46.92							
	455.23	78.31	69.31	58.98	52.21							
	513.97	70.37	62.30	53.00	46.92							
	596.87	70.37	62.30	53.00	46.92							
	638.79	71.09	63.07	53.59	47.39							
	721.22	70.37	62.30	53.00	46.92							
	836.61	59.53	52.67	44.81	39.72							
	1005.54	60.75	53.78	45.77	40.50							



	i	Mc [kNm]				n _{1max} [min ⁻¹]	Pt [kW]	Kg				
		n ₂ x h	n ₂ x h	n ₂ x h	n ₂ x h			M	P	CPC	F	FS
		10.000	20.000	50.000	100.000							
PGA 6503	47.01	74.97	60.91	46.29	37.61	2500	35	539	-	643	481	495
	61.11	78.31	69.31	55.62	45.19							
	71.42	58.38	54.93	42.18	34.24							
	92.85	74.16	66.76	50.68	41.15							
	111.59	60.75	53.78	45.77	40.50							
PGA 6504	193.86	66.72	54.20	41.19	33.46	2800	25	514	-	618	456	470
	234.14	64.53	57.14	47.01	38.19							
	252.01	78.31	65.13	49.49	40.20							
	304.38	78.31	69.31	56.48	45.89							
	343.65	70.37	62.30	53.00	46.92							
	413.04	60.75	53.78	45.77	40.50							
	479.13	60.75	53.78	45.77	40.50							
	576.57	57.69	53.78	45.77	40.50							
	650.97	60.75	53.78	45.77	40.50							
	755.12	60.75	53.78	45.77	40.50							
	911.35	56.01	49.57	42.23	37.34							



(n₂ x h = 20.000)

$$M_{\max} = M_C \times 2$$

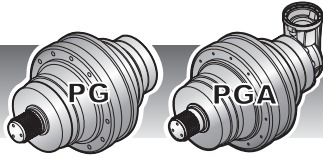

6500

IT EN DE FR ES PT

MS

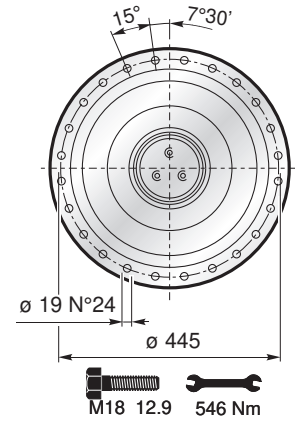
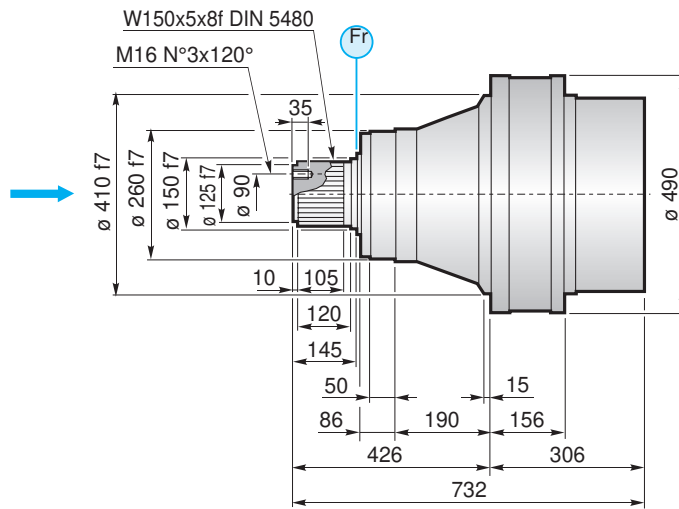
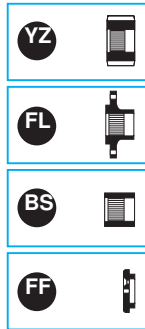

MC

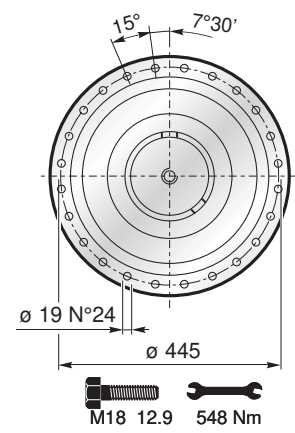
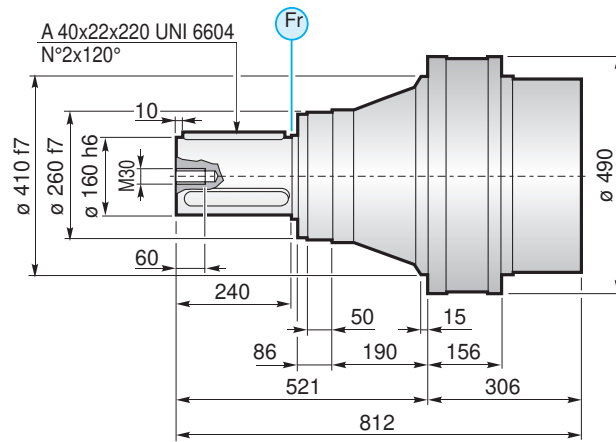



6500

IT EN DE FR ES PT

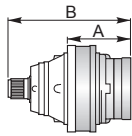
	PG ...MS					
	A	B	RA	RB	EF	EDF
PG6501	306	732				
PG6502	488	914				
PG6503	582	1008		•		
PG6504	614.5	1067.5	•	o	•	

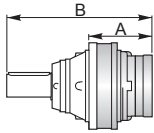
	PG ...MC					
	A	B	RA	RB	EF	EDF
PG6501	306	812				
PG6502	488	994				
PG6503	582	1088		•		
PG6504	641.5	1147.5	•	o	•	

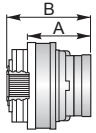
	PG ...F					
	A	B	RA	RB	EF	EDF
PG6501	296	396				
PG6502	478	578				
PG6503	572	672		•		
PG6504	631.5	631.5	•	o	•	

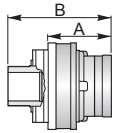
	PG ...FS					
	A	B	RA	RB	EF	EDF
PG6501	296	536				
PG6502	478	718				
PG6503	572	812		•		
PG6504	631.5	871.5	•	o	•	

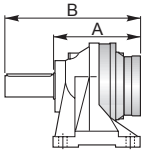
	PG ...CPC					
	A	B	RA	RB	EF	EDF
PG6501	572	812				
PG6502	754	994				
PG6503	848	1088		•		
PG6504	907.5	1147.5	•	o	•	

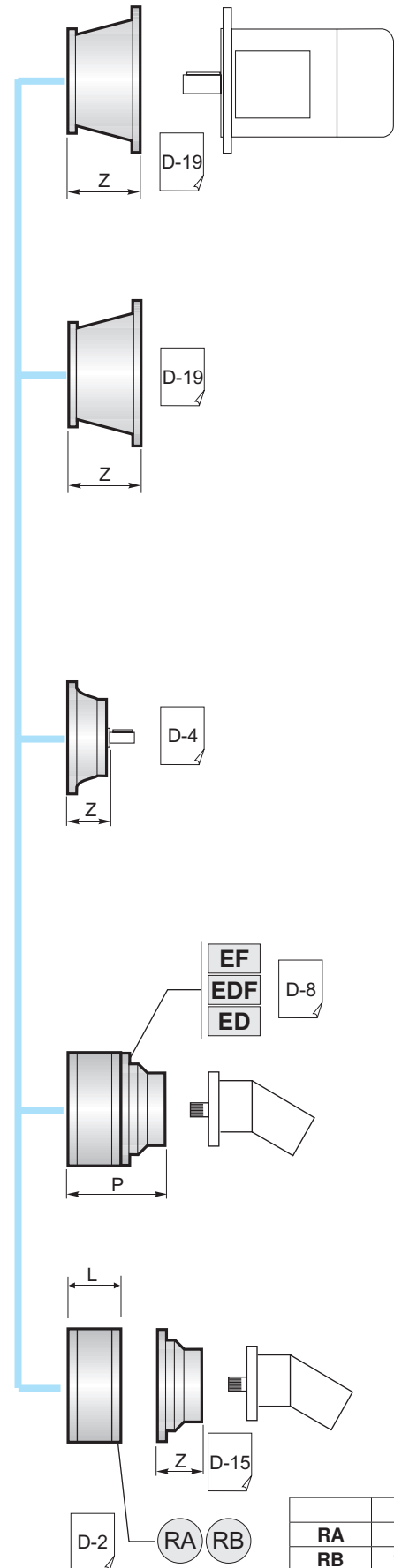

A	B	•
A+13.5	B+13.5	o

RA	L
RB	125

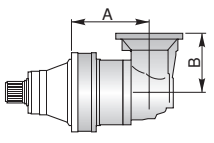

	PGA ...MS				
	A	B	RA	RB	EF
PGA 6503	568	315		•	
PGA 6504	670	240	•	o	•

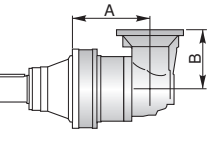
	PGA ...MC				
	A	B	RA	RB	EF
PGA 6503	568	315		•	
PGA 6504	670	240	•	o	•

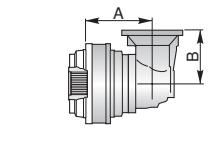
	PGA ...F				
	A	B	RA	RB	EF
PGA 6503	558	315		•	
PGA 6504	660	240	•	o	•

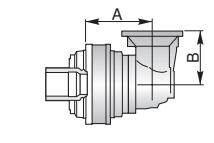
	PGA ...FS				
	A	B	RA	RB	EF
PGA 6503	558	315		•	
PGA 6504	660	240	•	o	•

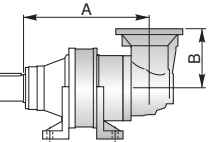
	PGA ...CPC				
	A	B	RA	RB	EF
PGA 6503	834	315		•	
PGA 6504	936	240	•	o	•

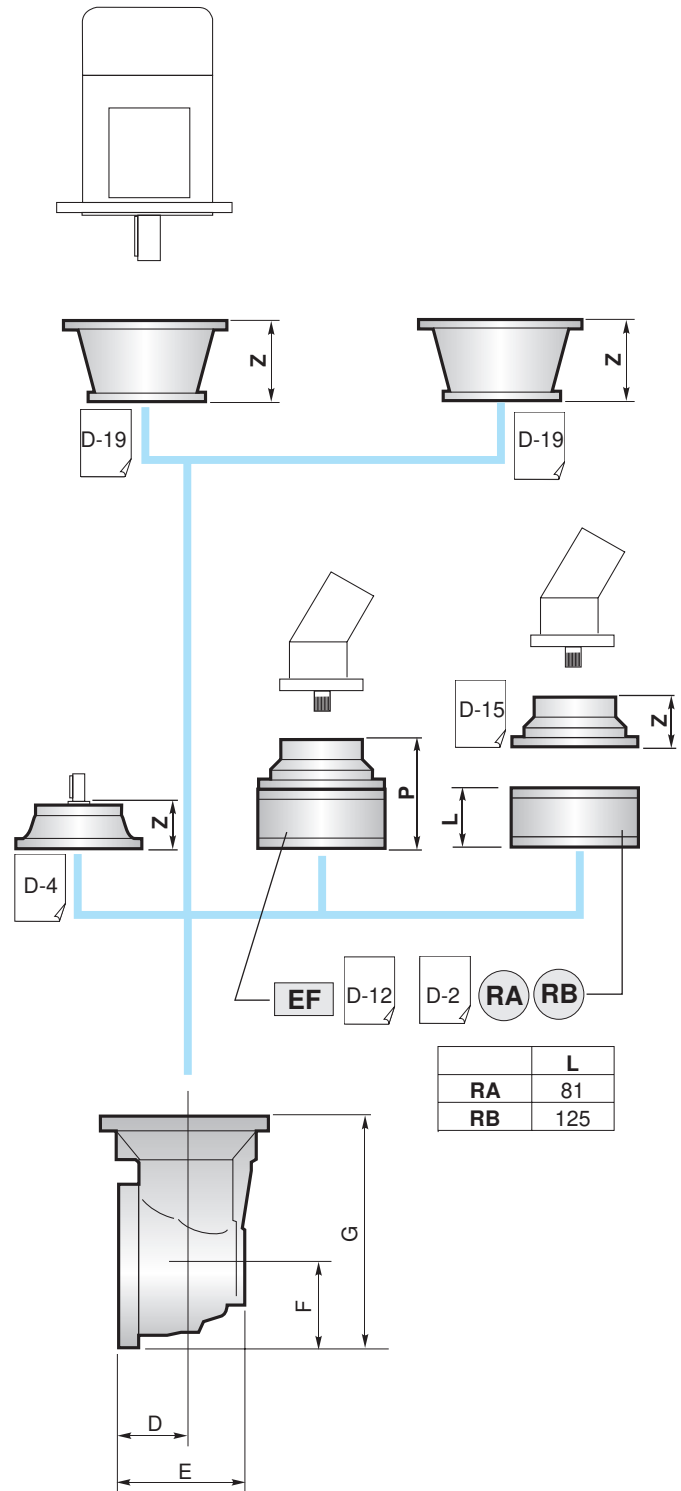

6500

	D	E	F	G
PGA 6503	88	256	235	550
PGA 6504	88	164	140	380

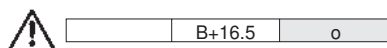

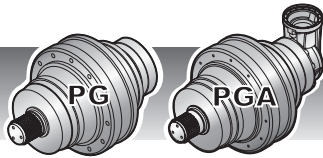

6500

IT EN DE FR ES PT

BS

Boccola scanalata / Splined bushing
Innenverzahnte Buchse / Moyeu cannelé
Casquillo ranurado / Bucha estriada

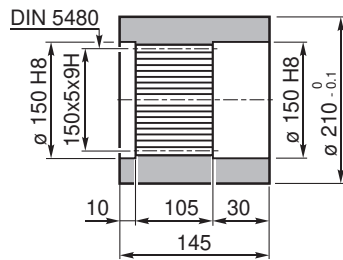

Materiale / Material
Material / Matière
Material / Material
UNI C40
SAE 1040
DIN Ck40

Codice / Code
Bestell - Nr. / Code
Código / Código

1720.102.076

KB

Barra scanalata / Splined rod
Außenverzahnte Welle / Arbre cannelé
Barra ranurada / Barra estriada

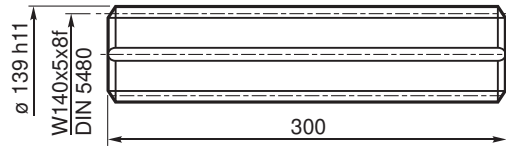

Materiale / Material
Material / Matière
Material / Material

UNI 16CrNi4
bonificato / hardened and tempered
vergütet / bonifié
bonificado / endurecido e temperado

Codice / Code
Bestell - Nr. / Code
Código / Código

1703.564.042

FL

Flangia / Flange
Flansch / Bride
Brida / Flange

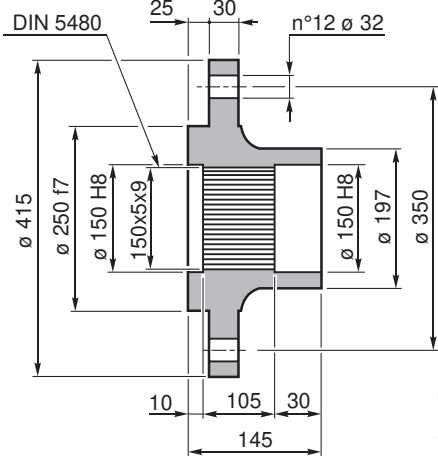

Codice / Code
Bestell - Nr. / Code
Código / Código

1720.106.098

GA

Giunto di attrito / Shrink disc
Schrumpfscheibe / Frette de serrage
Disco de contracción / Disco de contração

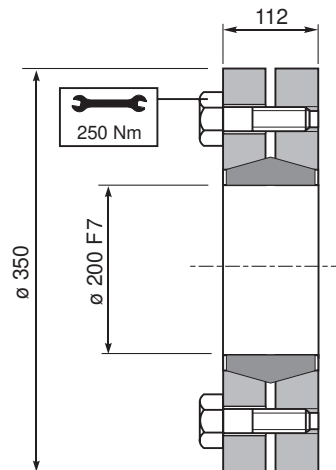

Coppia max.
Max. torque
Max. Drehmoment
Couple max.
Momento máx.
Torque máx.

92,5 kNm

Codice / Code
Bestell - Nr. / Code
Código / Código

9015.200.000

FF

Fondello di arresto / Stop bottom plate
Endscheibe / Bouchon de fermeture
Tapón de detención / Fundo de batente

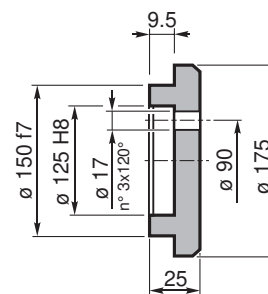

Codice / Code
Bestell - Nr. / Code
Código / Código

5701.043.000

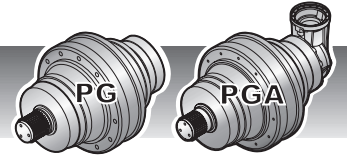

CARICHI RADIALI (Fr)

Nei diagrammi seguenti sono riportati i carichi radiali e i coefficienti K per rapportarli al valore $n_2 \times h$ desiderato.

RADIAL LOADS (Fr)

The following curves show the radial loads and the K factors to obtain the required $n_2 \times h$ value.

RADIALLAST (Fr)

In den nachstehenden Diagrammen ist die Radiallast und der Koeffizient K dargestellt und kann mit dem gewünschten Wert $n_2 \times h$ verglichen werden.

CHARGES RADIALES (Fr)

Dans les diagrammes suivants sont indiqués les charges radiales et les facteurs K de façon à obtenir la valeur $n_2 \times h$ désirée.

CARGAS RADIALES (Fr)

En los siguientes diagramas se indican las cargas radiales y los coeficientes K para obtener el valor requerido $n_2 \times h$.

CARGAS RADIAIS (Fr)

Nos diagramas seguintes são indicadas as cargas radiais e os coeficientes K para obter o valor $n_2 \times h$ desejado.

M - CPC*

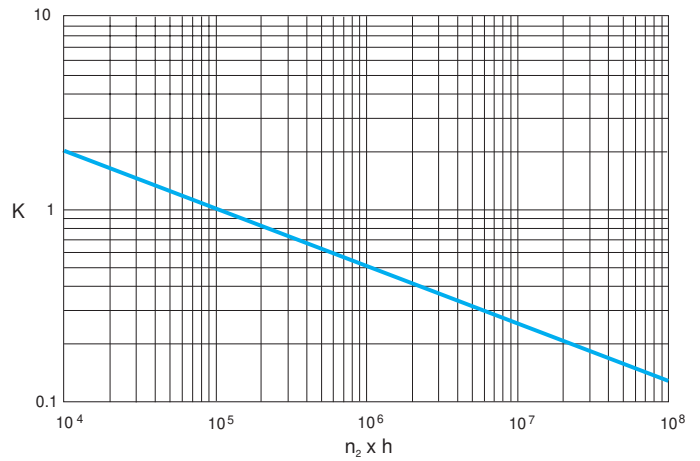
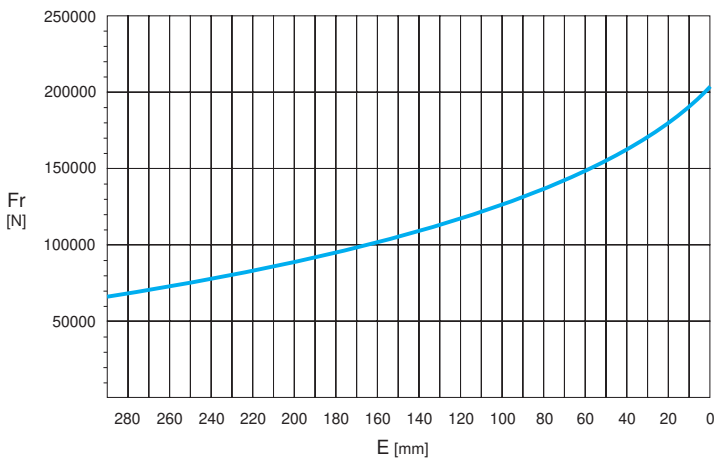

	$n_2 \times h$			
	10^5	10^4	10^6	10^7
M	Fr		Fr • K	
*CPC	Fr • 0.75		Fr • K • 0.75	

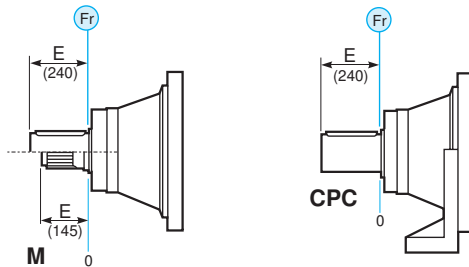

6500

CARICHI ASSIALI (Fa)

I valori dei carichi assiali indicati in tabella sono riferiti alle versioni e alla direzione di applicazione del carico.

AXIAL LOADS (Fa)

The values of the axial loads in the table refer to the output versions and load direction of application.

AXIALLAST (Fa)

Die dargestellten Werte der Axiallast basieren auf der Version und der applizierten Lastrichtung.

CHARGES AXIALES (Fa)

Les valeurs des charges axiales indiquées dans le tableau se réfèrent aux versions et à la direction d'application de la charge.

CARGAS AXIALES (Fa)

Los valores de las cargas axiales indicados en la tabla se refieren a las versiones y a la dirección de aplicación de la carga.

CARGAS AXIAIS (Fa)

Os valores das cargas axiais indicadas na tabela referem-se às versões e à direção de aplicação da carga.

Fa [N]	M	CPC	← →
	50000	50000	
100000	100000	100000	

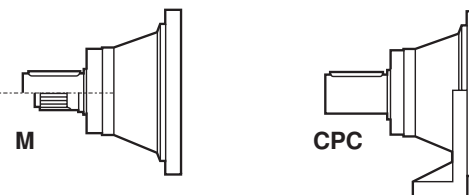



9000

IT EN DE FR ES PT

	i	Mc [kNm]				n _{1max} [min ⁻¹]	Pt [kW]	Kg				
		n ₂ x h	n ₂ x h	n ₂ x h	n ₂ x h			M	P	CPC	F	FS
		10.000	20.000	50.000	100.000							
PG 9001	4.04	111.85	99.00	84.25	74.57	750	80	519	-	691	423	445
	5.12	89.26	79.00	67.23	59.50							
PG 9002	16.17	106.58	94.34	80.30	71.06	1500	65	635	.	807	539	561
	20.47	89.26	79.00	67.23	59.50							
	21.03	82.41	72.93	62.08	54.93							
	26.61	89.26	79.00	67.23	59.50							
	31.99	77.20	68.34	58.17	51.47							
PG 9003	59.30	73.98	65.49	55.69	49.35	2500	45	662	-	834	566	588
	75.06	89.26	79.00	67.23	59.50							
	93.12	82.41	72.93	62.08	54.93							
	97.58	89.26	79.00	67.23	59.50							
	105.13	73.65	65.20	55.47	49.10							
	117.85	89.26	79.00	67.23	59.50							
	133.06	89.26	79.00	67.23	59.50							
	141.65	77.20	68.34	58.17	51.47							
	159.93	77.20	68.34	58.17	51.47							
	185.51	77.20	68.34	58.17	51.47							
PG 9004	224.04	73.98	65.49	55.69	49.35	2800	30	673	-	845	577	599
	244.63	73.98	65.49	55.69	49.35							
	283.56	89.26	79.00	67.23	59.50							
	309.62	89.26	79.00	67.23	59.50							
	351.77	82.41	72.93	62.08	54.93							
	402.50	89.26	79.00	67.23	59.50							
	445.22	89.26	79.00	67.23	59.50							
	468.39	82.01	72.61	61.74	54.71							
	504.15	89.26	79.00	67.23	59.50							
	548.87	89.26	79.00	67.23	59.50							
	585.46	89.26	79.00	67.23	59.50							
	687.47	89.26	79.00	67.23	59.50							
	798.35	89.26	79.00	67.23	59.50							
	854.43	89.26	79.00	67.23	59.50							
	964.68	89.26	79.00	67.23	59.50							
	1113.09	77.20	68.34	58.17	51.47							
1344.98	77.20	68.34	58.17	51.47								
PG 9005	1431.12	89.26	79.00	67.23	59.50	2800	26	679	-	851	583	605
	1579.81	89.26	79.00	67.23	59.50							
	1662.02	89.26	79.00	67.23	59.50							
	1787.26	89.26	79.00	67.23	59.50							
	1908.08	89.26	79.00	67.23	59.50							
	2064.28	89.26	79.00	67.23	59.50							
	2154.29	89.26	79.00	67.23	59.50							
	2493.23	89.26	79.00	67.23	59.50							
	3429.96	89.26	79.00	67.23	59.50							
	4470.78	89.26	79.00	67.23	59.50							
	5402.19	89.26	79.00	67.23	59.50							
	6511.57	89.26	79.00	67.23	59.50							
	7405.04	89.26	79.00	67.23	59.50							
	8360.53	89.26	79.00	67.23	59.50							



	i	Mc [kNm]				n _{1max} [min ⁻¹]	Pt [kW]	Kg				
		n ₂ x h	n ₂ x h	n ₂ x h	n ₂ x h			M	P	CPC	F	FS
		10.000	20.000	50.000	100.000							
PGA 9003	49.68	77.93	63.32	48.12	39.09	2500	45	699	-	871	603	625
	62.87	89.26	74.67	56.74	46.10							
	81.74	89.26	79.00	67.23	55.40							
	98.12	78.00	69.39	52.68	42.77							
	124.19	89.26	79.00	62.13	50.44							
	149.26	77.20	68.34	58.17	51.47							
PGA 9004	247.44	67.54	59.80	48.86	39.69	2800	30	720	-	892	624	646
	266.33	82.41	67.70	51.44	41.79							
	313.17	82.01	72.61	57.62	46.81							
	337.08	89.26	79.00	60.66	49.28							
	407.13	89.26	79.00	67.23	56.25							
	489.33	77.20	68.34	58.17	51.47							
	724.43	70.28	65.55	59.79	54.65							
	840.34	75.66	66.94	56.95	50.48							
	1010.02	77.20	68.34	58.17	51.47							

9000



(n₂ x h = 20.000)

$$M_{\max} = M_c \times 2$$

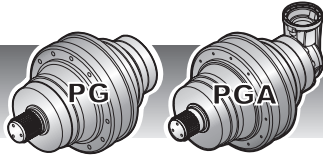

9000

IT EN DE FR ES PT

MS

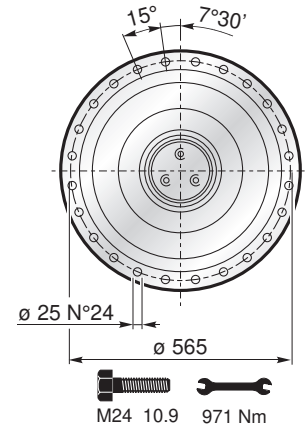
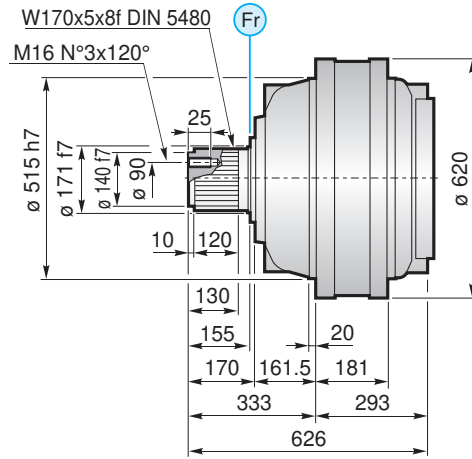
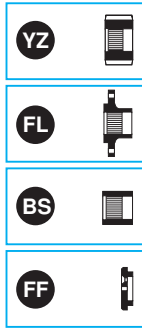

MC

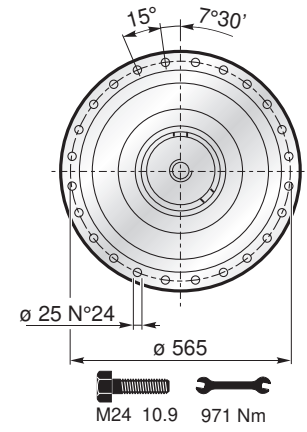
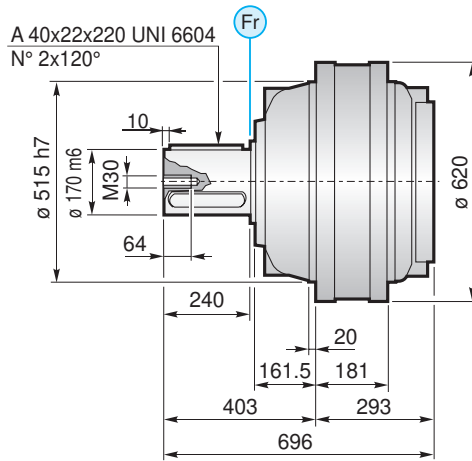

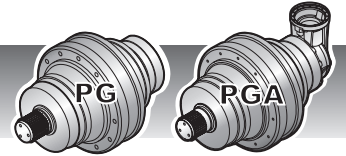

F

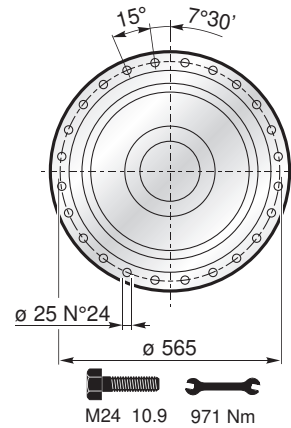
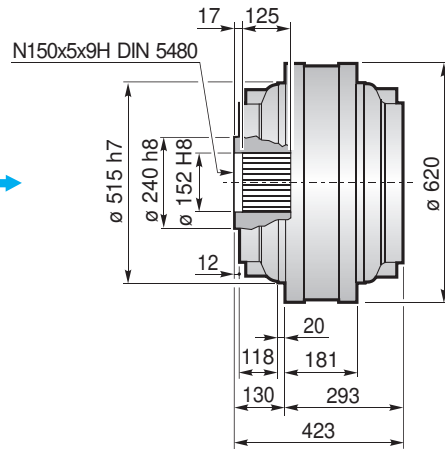

FS

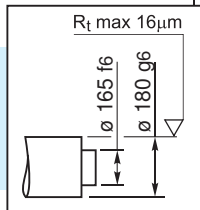
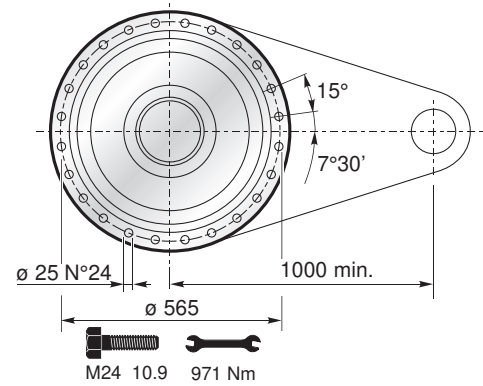
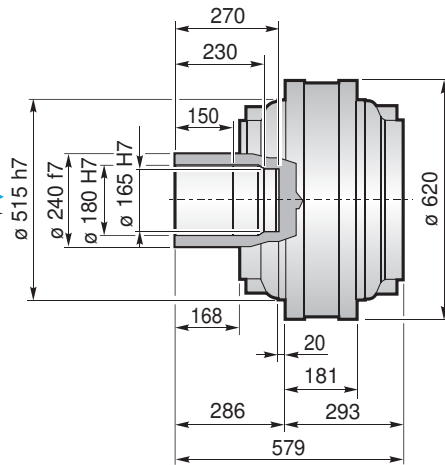

$M_{max} = 176 \text{ kNm}$

La coppia massima indicata è valida solo con calettatori forniti da Planetary Drives
 The maximum torque indicated is valid only with shrink discs supplied by Planetary Drives
 Das dargestellte, maximale Drehmoment gilt nur mit von Planetary Drives gelieferter Schrumpfscheibe
 Le couple maximal indiqué n'est valable qu'avec les frettes de serrage fournis par Planetary Drives
 El momento máximo indicado sólo es válido con discos de contracción suministrados por Planetary Drives
 O torque máximo indicado é válido exclusivamente com discos de contração fornecidos pela Planetary Drives

9000

CPC

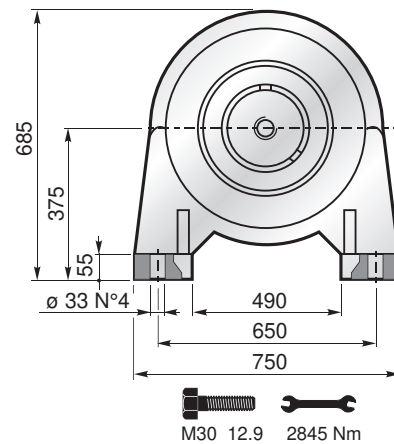
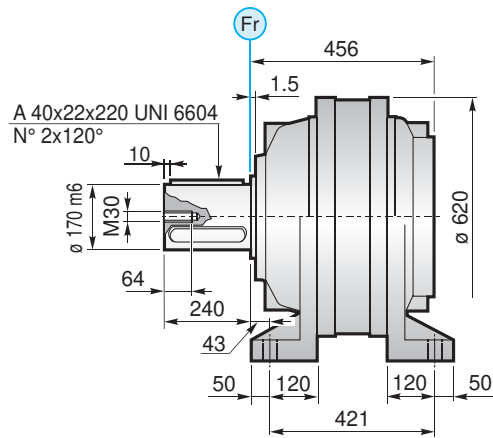

FL YZ BS FF KB GA → B-114



9000

IT EN DE FR ES PT

	PG ...MS					
	A	B	RA	RB	EF	EDF
PG 9001	293	626				
PG 9002	475	808				
PG 9003	569	902		•		
PG 9004	628.5	961.5	•	o	•	

	PG ...MC					
	A	B	RA	RB	EF	EDF
PG 9001	293	696				
PG 9002	475	878				
PG 9003	569	972		•		
PG 9004	628.5	1031.5	•	o	•	

	PG ...F					
	A	B	RA	RB	EF	EDF
PG 9001	293	423				
PG 9002	475	605				
PG 9003	569	699		•		
PG 9004	628.5	758.5	•	o	•	

	PG ...FS					
	A	B	RA	RB	EF	EDF
PG 9001	293	579				
PG 9002	475	761				
PG 9003	569	855		•		
PG 9004	628.5	914.5	•	o	•	

	PG ...CPC					
	A	B	RA	RB	EF	EDF
PG 9001	456	696				
PG 9002	638	878				
PG 9003	732	972		•		
PG 9004	791.5	1031.5	•	o	•	

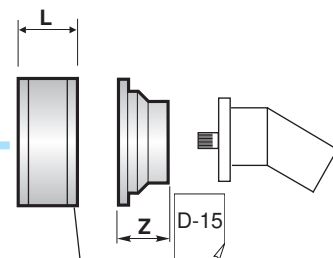
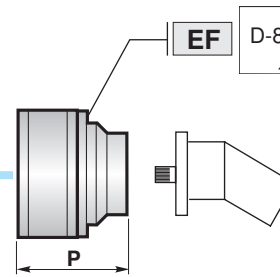
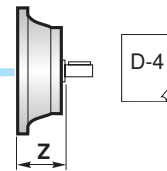
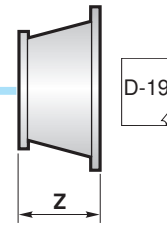
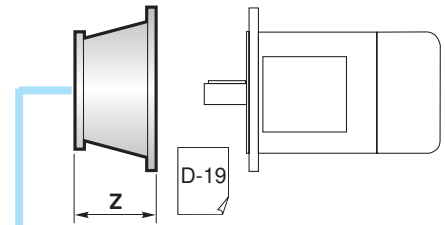

D-2	RA	RB	L
	RA	RB	81 125

	A+13.5	B+13.5	o
--	--------	--------	---



		PGA ...MS				
		A	B	RA	RB	EF
PGA 9003		555	315		•	
PGA 9004		657	240	•	o	•

		PGA ...MC				
		A	B	RA		EF
PGA 9003		555	315			•
PGA 9004		657	240	•	o	•

		PGA ...F				
		A	B	RA	RB	EF
PGA 9003		555	315			•
PGA 9004		657	240	•	o	•

		PGA ...FS				
		A	B	RA	RB	EF
PGA 9003		555	315			•
PGA 9004		657	240	•	o	•

		PGA ...CPC				
		A	B	RA	RB	EF
PGA 9003		718	315			•
PGA 9004		820	240	•	o	•

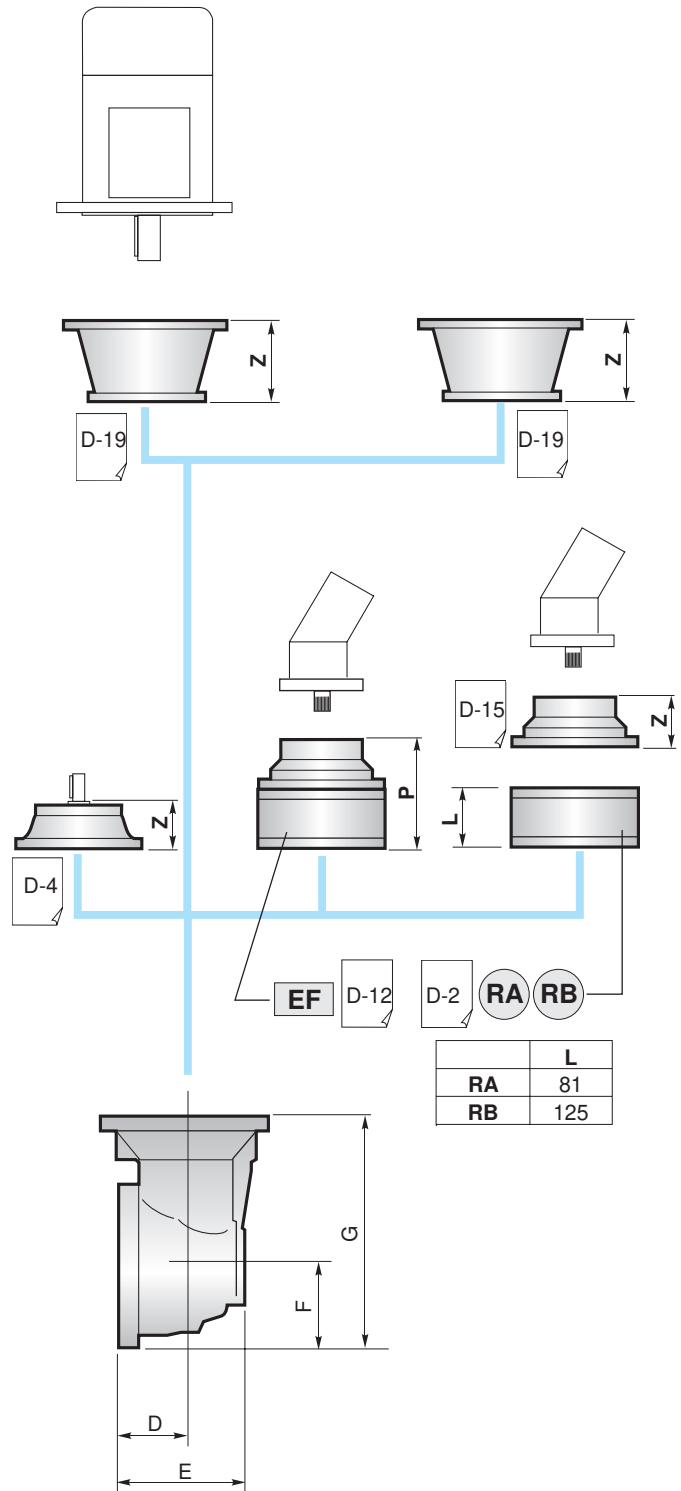

9000

	D	E	F	G
PGA 9003	88	256	235	550
PGA 9004	88	164	140	380

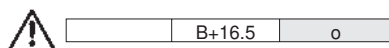

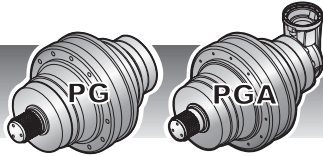

9000

IT EN DE FR ES PT

BS

Boccola scanalata / Splined bushing
Innenverzähnte Buchse / Moyeu cannelé
Casquillo ranurado / Bucha estriada

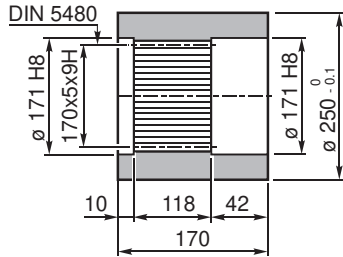

Materiale / Material
Material / Matière
Material / Material
UNI C40
SAE 1040
DIN Ck40

Codice / Code
Bestell - Nr. / Code
Código / Código

1721.115.076

FF

Fondello di arresto / Stop bottom plate
Endscheibe / Bouchon de fermeture
Tapón de detención / Fundo de batente

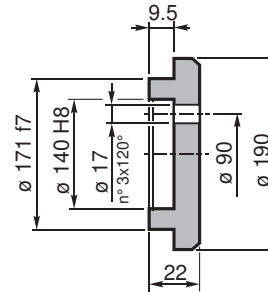

Codice / Code
Bestell - Nr. / Code
Código / Código

5701.044.000

FL

Flangia / Flange
Flansch / Bride
Brida / Flange

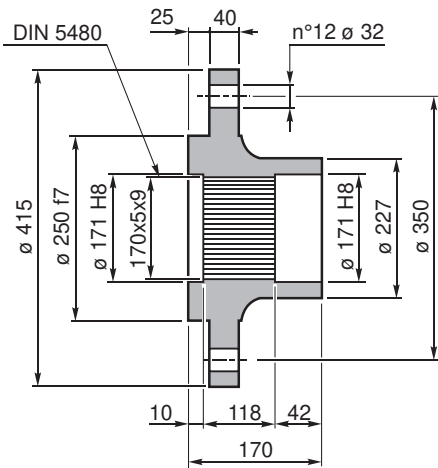

Codice / Code
Bestell - Nr. / Code
Código / Código

1721.133.098

GA

Giunto di attrito / Shrink disc
Schrumpfscheibe / Frette de serrage
Disco de contracción / Disco de contração

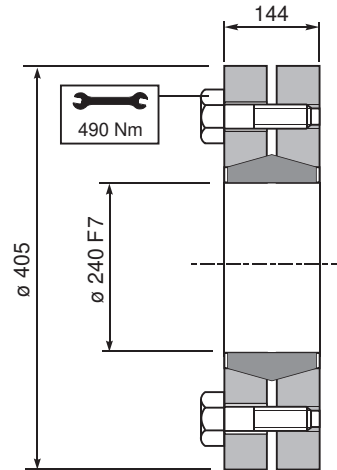

Coppia max.
Max. torque
Max. Drehmoment
Couple max.
Momento máx.
Torque máx.

176 kNm

Codice / Code
Bestell - Nr. / Code
Código / Código

9015.240.000

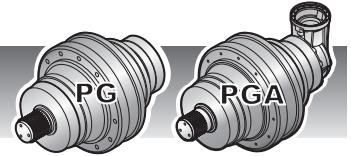

CARICHI RADIALI (Fr)

Nei diagrammi seguenti sono riportati i carichi radiali e i coefficienti K per rapportarli al valore $n_2 \times h$ desiderato.

RADIAL LOADS (Fr)

The following curves show the radial loads and the K factors to obtain the required $n_2 \times h$ value.

RADIALLAST (Fr)

In den nachstehenden Diagrammen ist die Radiallast und der Koeffizient K dargestellt und kann mit dem gewünschten Wert $n_2 \times h$ verglichen werden.

CHARGES RADIALES (Fr)

Dans les diagrammes suivants sont indiqués les charges radiales et les facteurs K de façon à obtenir la valeur $n_2 \times h$ désirée.

CARGAS RADIALES (Fr)

En los siguientes diagramas se indican las cargas radiales y los coeficientes K para obtener el valor requerido $n_2 \times h$.

CARGAS RADIAIS (Fr)

Nos diagramas seguintes são indicadas as cargas radiais e os coeficientes K para obter o valor $n_2 \times h$ desejado.

M - CPC*

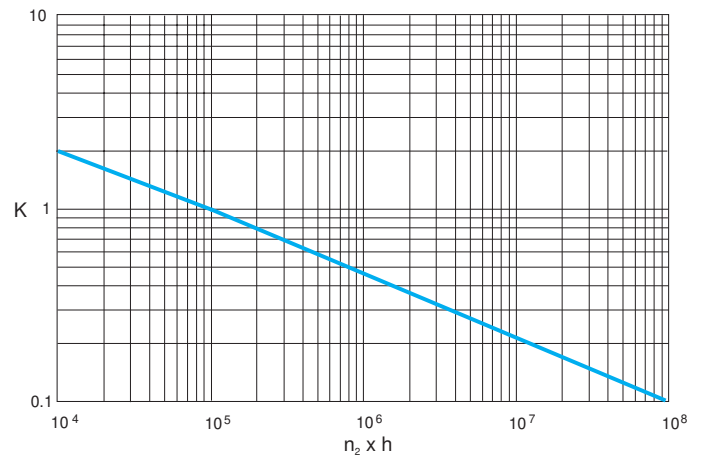
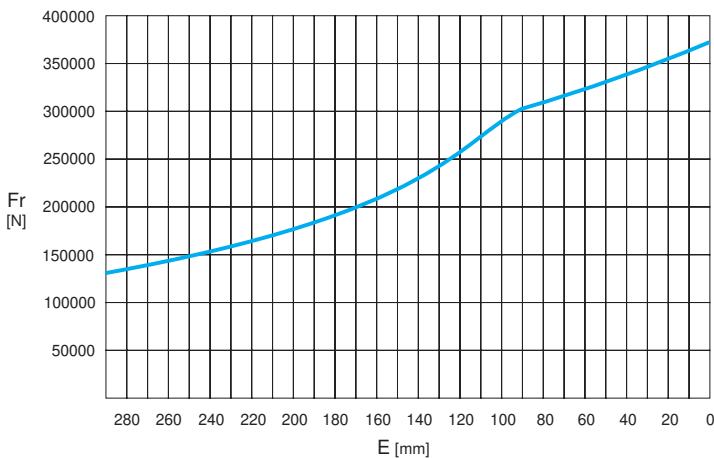

	$n_2 \times h$				
	10 ⁵	10 ⁴	10 ⁶	10 ⁷	10 ⁸
M	Fr		Fr • K		
*CPC	Fr • 0.75		Fr • K • 0.75		

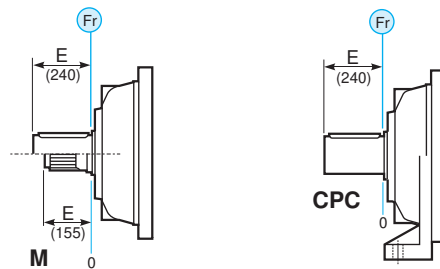

9000

CARICHI ASSIALI (Fa)

I valori dei carichi assiali indicati in tabella sono riferiti alle versioni e alla direzione di applicazione del carico.

AXIAL LOADS (Fa)

The values of the axial loads in the table refer to the output versions and load direction of application.

AXIALLAST (Fa)

Die dargestellten Werte der Axiallast basieren auf der Version und der applizierten Lastrichtung.

CHARGES AXIALES (Fa)

Les valeurs des charges axiales indiquées dans le tableau se réfèrent aux versions et à la direction d'application de la charge.

CARGAS AXIALES (Fa)

Los valores de las cargas axiales indicados en la tabla se refieren a las versiones y a la dirección de aplicación de la carga.

CARGAS AXIAIS (Fa)

Os valores das cargas axiais indicadas na tabela referem-se às versões e à direção de aplicação da carga.

Fa [N]	M	CPC	
	40000	40000	←
70000	70000	→	

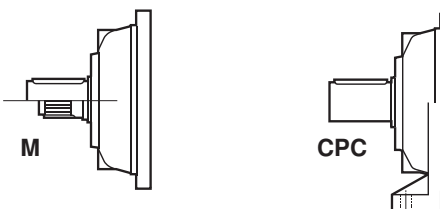

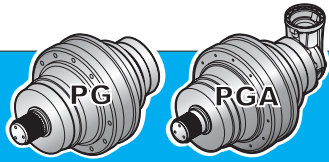

		i	Mc _(n₂h 20.000) [kNm]	
B	(100 ÷ 9000)	(3.56 ÷ 8360.53)	(0.45 ÷ 99.00)	B-1
	C	(12000 ÷ 61000)	(3.43 ÷ 8938.38)	C-1
12000	PG	4.09 ÷ 5665.81	94.3 ÷ 163.4	C-2
	PGA	50.25 ÷ 5566.69	55.6 ÷ 120.8	
16000	PG	3.83 ÷ 8729.66	116.7 ÷ 212.5	C-10
	PGA	59.55 ÷ 7033.95	65.6 ÷ 146.3	
21000	PG	3.68 ÷ 8127.84	114.2 ÷ 238.2	C-18
	PGA	60.00 ÷ 7897.21	71.8 ÷ 181.1	
26000	PG	3.68 ÷ 8018.87	185.9 ÷ 288.7	C-26
	PGA	182.81 ÷ 6021.84	155.3 ÷ 224.2	
31000	PG	3.43 ÷ 8522.08	128.4 ÷ 364.4	C-34
	PGA	264.13 ÷ 6399.72	203.9 ÷ 309.8	
40000	PG	3.43 ÷ 8938.38	262.2 ÷ 452.7	C-42
	PGA	263.81 ÷ 6279.06	257.0 ÷ 338.9	
45000	PG	3.83 ÷ 4952.48	305.8 ÷ 567.4	C-50
	PGA	634.60 ÷ 3187.80	342.6 ÷ 444.8	
53000	PG	3.84 ÷ 7890.76	394.1 ÷ 727.2	C-58
	PGA	819.22 ÷ 5079.11	386.5 ÷ 463.5	
61000	PG	3.84 ÷ 3175.35	448.6 ÷ 858.1	C-62
	PGA	863.53 ÷ 2116.90	401.0 ÷ 463.5	

Le pagine che seguono riportano i dati tecnici prestazionali e dimensionali dei riduttori Serie PG-PGA. Per facilitare la ricerca della grandezza desiderata riportiamo la tabella sopraindicata con i dati indicativi e i riferimenti alle pagine.

The following pages show the technical information on performances and dimensions of the PG-PGA planetary the research and the selection of the required size you can refer to the above table, including some technical data and the corresponding page.

Die folgenden Seiten zeigen die technischen Daten bezüglich Leistung und Dimensionen der Produktserien PG-PGA. Um die Suche der gewünschten Groesse zu erleichtern, liefert die vorstehende Tabelle die Groessen in Verbindung zur entsprechenden Katalogseite.

Les page qui suivent se rapportent aux données techniques des prestations et dimensions des réducteurs série PG-PGA. Pour faciliter la sélection de la taille du réducteur envisagée, se référer au tableau ci-dessus pour se reporter à la page correspondante.

Las páginas siguientes contienen los datos técnicos de las prestaciones y dimensiones de la serie de reductores PG-PGA. Para facilitar la búsqueda de la dimensión deseada se puede consultar la siguiente tabla, con los datos indicativos y las páginas correspondientes.

As páginas seguintes mostram os dados técnicos de desempenho e as características dimensionais dos reductores da Série PG-PGA. Para facilitar a procura do tamanho desejado, reproduzimos a tabela a seguir com os dados indicativos e as referências às páginas.



12000

IT EN DE FR ES PT

	i	Mc [kNm]				n _{1max} [min ⁻¹]	Pt [kW]	Kg				
		n ₂ x h	n ₂ x h	n ₂ x h	n ₂ x h			M	P	CPC	F	FS
		10.000	20.000	50.000	100.000							
PG 12001	4.09	181.5	163.4	142.3	129.4	750	102	650	-	-	615	642
	5.25	134.2	120.8	105.2	98.6							
	6.23	105.4	94.9	82.7	79.0							
PG 12002	16.36	131.2	116.1	98.8	87.5	1200	60	762	-	-	727	754
	19.25	111.8	98.9	84.2	74.5							
	21.00	134.2	120.8	105.2	98.6							
	24.71	134.2	120.8	103.4	91.5							
	29.32	105.4	94.9	82.7	79.0							
PG 12003	58.17	129.9	114.9	97.8	86.6	2000	45	797	-	-	762	789
	68.43	111.8	98.9	84.2	74.5							
	74.67	134.2	120.8	105.2	98.6							
	90.00	134.2	120.8	103.3	91.4							
	117.60	106.6	94.3	80.2	71.1							
	139.55	105.4	94.9	82.7	79.0							
	164.18	105.4	94.9	82.7	79.0							
	197.89	105.4	94.8	80.6	71.4							
PG 12004	219.75	129.9	114.9	97.8	86.6	2800	33	812	-	-	777	804
	239.95	129.9	114.9	97.8	86.6							
	258.53	111.8	98.9	84.2	74.5							
	282.07	134.2	120.8	105.2	98.6							
	308.00	134.2	120.8	105.2	98.6							
	340.00	134.2	120.8	103.3	91.4							
	385.78	134.2	120.8	103.5	91.7							
	448.00	120.4	106.7	90.7	80.5							
	485.10	106.6	94.3	80.2	71.1							
	540.00	134.2	120.8	103.3	91.4							
	607.60	106.6	94.3	80.2	71.1							
	652.50	109.9	97.2	82.7	73.4							
	705.60	106.6	94.3	80.2	71.1							
	816.31	105.4	94.8	80.6	71.4							
	1190.30	105.4	94.9	82.7	79.0							
PG 12005	781.33	129.9	114.9	97.8	86.6	2800	27	822	-	-	787	814
	853.14	129.9	114.9	97.8	86.6							
	941.78	129.9	114.9	97.8	86.6							
	1002.93	134.2	120.8	105.2	98.6							
	1095.11	134.2	120.8	105.2	98.6							
	1208.89	134.2	120.8	105.2	98.6							
	1371.65	134.2	120.8	103.5	91.7							
	1579.61	126.7	111.9	95.2	84.1							
	1724.80	134.2	120.3	102.4	90.5							
	1904.00	134.2	120.8	103.3	91.4							
	2160.36	134.2	120.8	103.5	91.7							
	2604.00	134.2	120.8	103.3	91.4							
	3024.00	134.2	120.8	103.3	91.4							
	3402.56	106.6	94.3	80.2	71.1							
	4037.70	105.4	94.9	82.7	79.0							
5665.81	105.4	94.9	82.7	79.0								



	i	Mc [kNm]				n _{1max} [min ⁻¹]	Pt [kW]	Kg				
		n ₂ x h	n ₂ x h	n ₂ x h	n ₂ x h			M	P	CPC	F	FS
		10.000	20.000	50.000	100.000							
PGA 12003	50.25	78.6	63.8	48.5	39.4	2000	45	845	-	-	810	837
	59.12	88.0	71.5	54.3	44.2							
	64.50	93.6	76.0	57.8	46.9							
	75.88	104.8	85.2	64.7	52.6							
	90.05	105.4	94.9	73.0	59.3							
	116.29	91.1	78.2	59.3	48.2							
PGA 12004	200.95	68.4	55.6	42.2	34.3	2800	33	870	-	-	835	862
	284.96	87.4	71.0	53.9	43.8							
	368.95	104.7	85.0	64.6	52.5							
	434.05	105.4	94.9	72.4	58.8							
	482.09	105.4	94.9	77.9	63.3							
	567.16	105.4	94.9	82.7	70.9							
	683.63	105.4	94.8	80.6	71.4							
	771.75	74.2	69.2	61.3	54.2							
PGA 12005	893.10	111.8	98.9	84.2	74.5	2'800	25	855	-	-	820	847
	1064.00	134.2	120.8	105.2	98.6							
	1174.55	134.2	120.8	103.3	91.4							
	1282.50	134.2	120.8	103.3	91.4							
	1453.28	111.6	98.8	84.1	74.4							
	1676.89	134.2	120.8	105.2	95.4							
	1865.45	134.2	120.8	103.3	91.4							
	2021.25	134.2	120.8	103.3	91.4							
	2196.65	105.4	94.9	82.7	79.0							
	2439.11	120.4	106.7	90.7	80.5							
	2610.75	105.4	94.9	82.7	79.0							
	2940.00	134.2	120.8	103.3	91.4							
	3146.89	105.4	94.9	82.7	79.0							
	3405.19	105.4	94.9	82.7	79.0							
	3552.50	109.9	97.2	82.7	73.4							
	4114.61	105.4	94.9	82.7	79.0							
	4959.57	105.4	94.9	82.7	79.0							
5566.69	105.4	94.8	80.6	71.4								

12000

(n₂ x h = 20.000)
M_{max} = M_c x 1.7

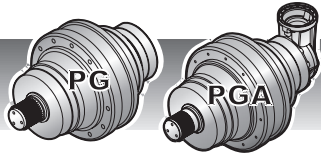

12000

IT EN DE FR ES PT

MS

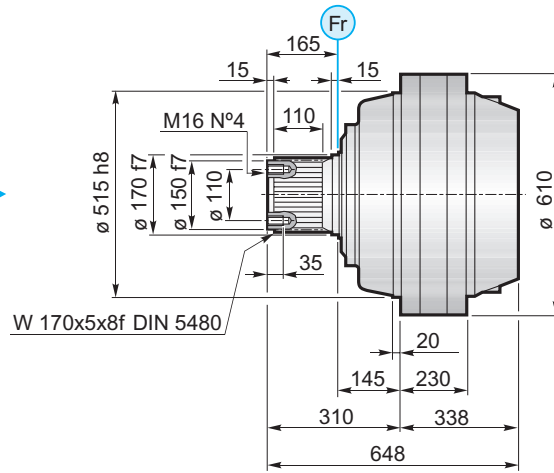
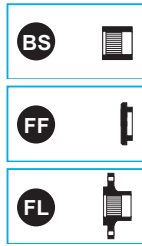

MC

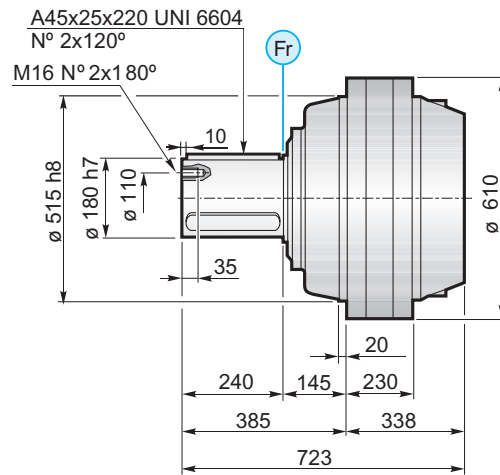

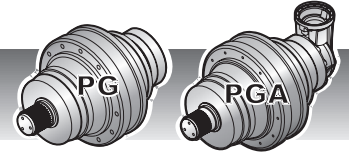

F

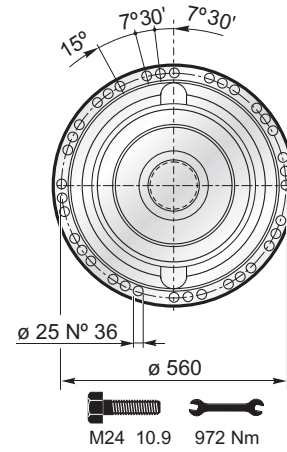
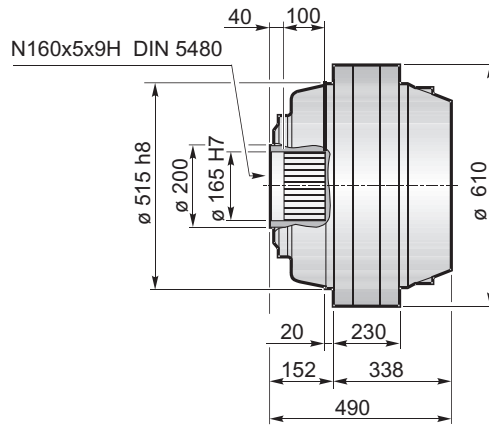

FS

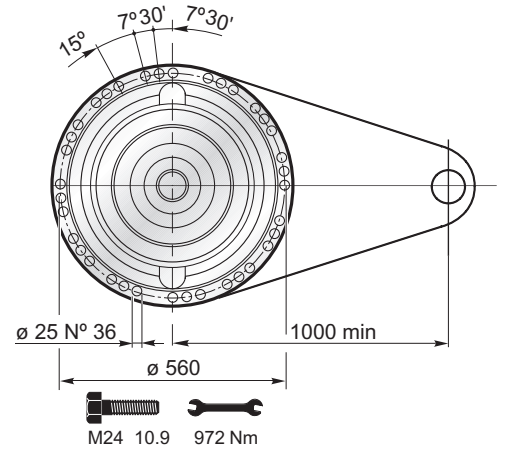
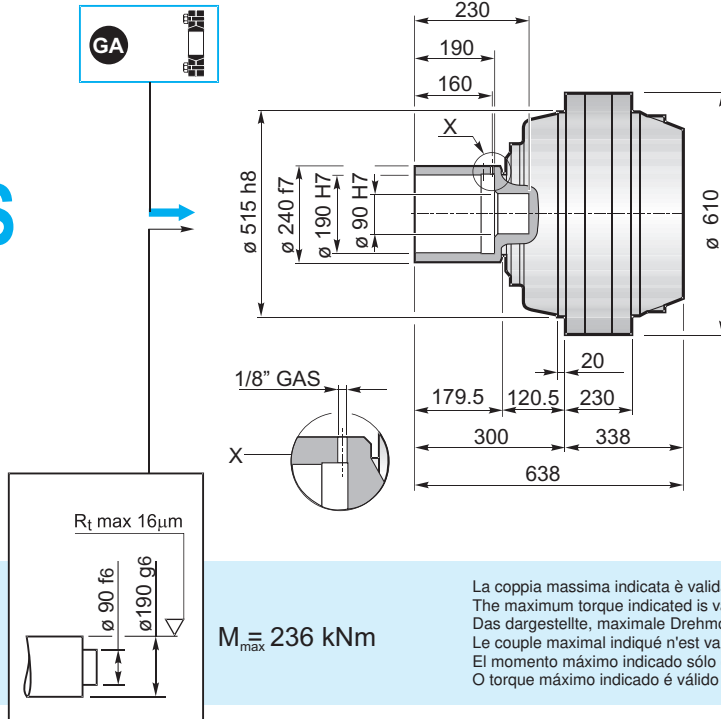

La coppia massima indicata è valida solo con calettatori forniti da Planetary Drives
 The maximum torque indicated is valid only with shrink discs supplied by Planetary Drives
 Das dargestellte, maximale Drehmoment gilt nur mit von Planetary Drives gelieferter Schrumpfscheibe
 Le couple maximal indiqué n'est valable qu'avec les frettes de serrage fournis par Planetary Drives
 El momento máximo indicado sólo es válido con discos de contracción suministrados por Planetary Drives
 O torque máximo indicado é válido exclusivamente com discos de contração fornecidos pela Planetary Drives

12000



12000

IT EN DE FR ES PT

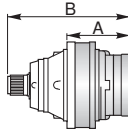
	PG ...MS					
	A	B	RA	RB	EF	EDF
PG12002	535	845				
PG12003	622	932		•		
PG12004	693.5	1003.5	•	o	•	
PG12005	754.5	1064.5	•			•

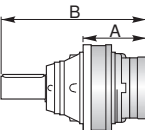
	PG ...MC					
	A	B	RA	RB	EF	EDF
PG12002	535	920				
PG12003	622	1007		•		
PG12004	693.5	1078.5	•	o	•	
PG12005	754.5	1139.5	•			•

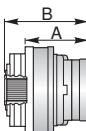
	PG ...F					
	A	B	RA	RB	EF	EDF
PG12002	535	687				
PG12003	622	774		•		
PG12004	693.5	845.5	•	o	•	
PG12005	754.5	906.5	•			•

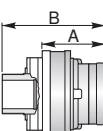
	PG ...FS					
	A	B	RA	RB	EF	EDF
PG12002	535	835				
PG12003	622	922		•		
PG12004	693.5	993.5	•	o	•	
PG12005	754.5	1054.5	•			•



A	B	•
A+13.5	B+13.5	o

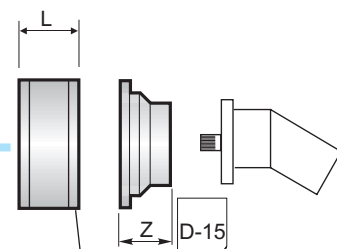
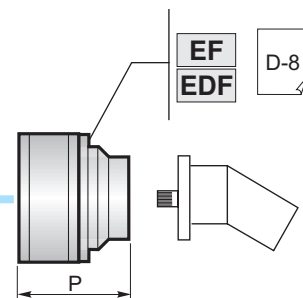
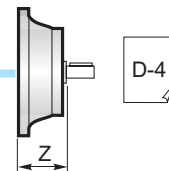
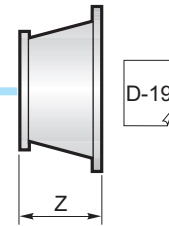
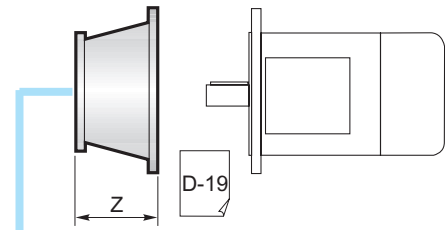

	L
RA	81
RB	125



	PGA ...MS					
	A	B	RA	RB	EF	EDF
PGA12003	600	315		•		
PGA12004	757	315		•		
PGA12005	795	240	•	o	•	

	PGA ...MC					
	A	B	RA	RB	EF	EDF
PGA12003	600	315		•		
PGA12004	757	315		•		
PGA12005	795	240	•	o	•	

	PGA ...F					
	A	B	RA	RB	EF	EDF
PGA12003	600	315		•		
PGA12004	757	315		•		
PGA12005	795	240	•	o	•	

	PGA ...FS					
	A	B	RA	RB	EF	EDF
PGA12003	600	315		•		
PGA12004	757	315		•		
PGA12005	795	240	•	o	•	



B	•
B+13.5	o

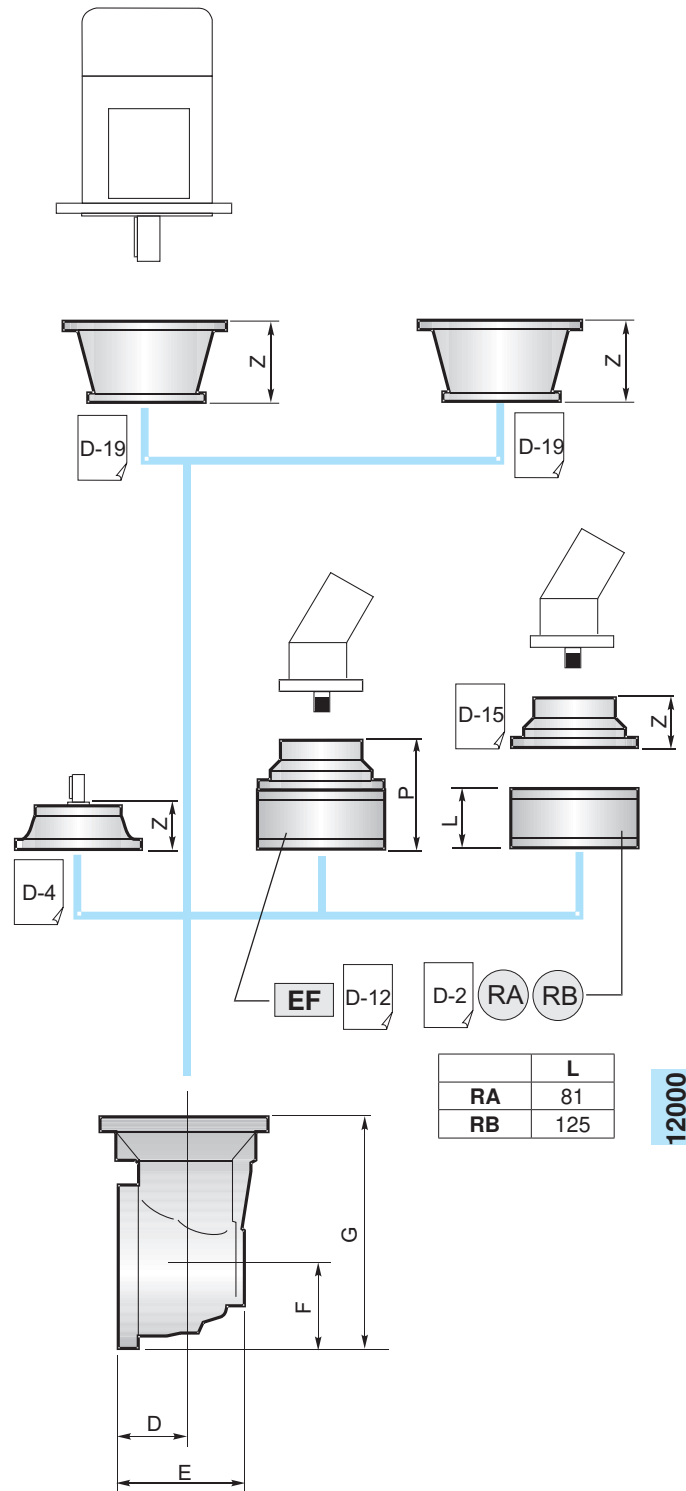

	L
RA	81
RB	125

	D	E	F	G
PGA12003	88	256	235	550
PGA12004	88	256	235	550
PGA12005	88	164	140	380

12000

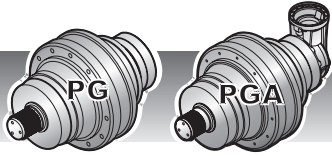

12000

IT EN DE FR ES PT

BS Boccia scanalata / Splined bushing
Innenverzahnte Buchse / Moyeu cannelé
Casquillo ranurado / Bucha estriada

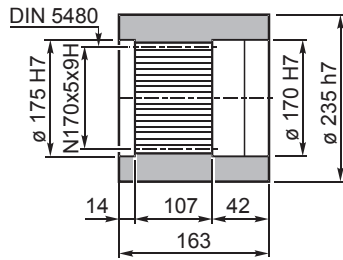

Materiale / Material
Material / Matière
Material / Material
UNI C40
SAE 1040
DIN Ck40

Codice / Code
Bestell - Nr. / Code
Código / Código

FF Fondello di arresto / Stop bottom plate
Endscheibe / Bouchon de fermeture
Tapón de detención / Fundo de batente

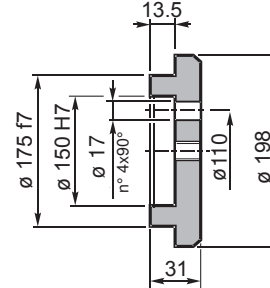

Codice / Code
Bestell - Nr. / Code
Código / Código

FL Flangia / Flange
Flansch / Bride
Brida / Flange

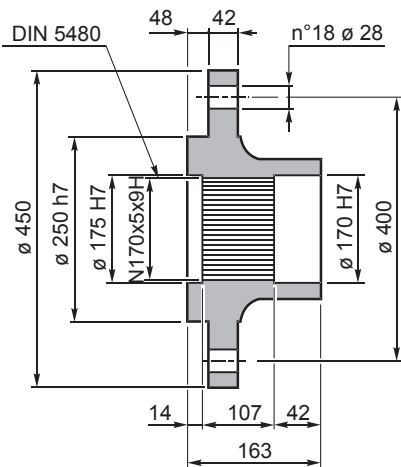

Codice / Code
Bestell - Nr. / Code
Código / Código

GA Giunto di attrito / Shrink disc
Schrumpfscheibe / Frette de serrage
Disco de contracción / Disco de contração

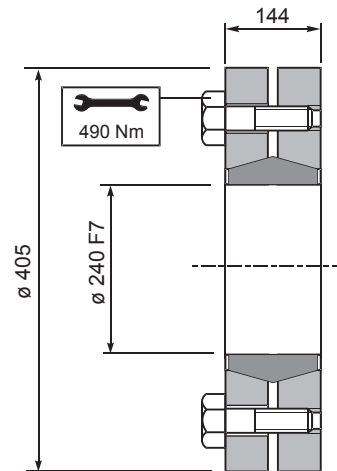

Coppia max.
Max. torque
Max. Drehmoment
Couple max.
Momento máx.
Torque máx.
236 kNm

Codice / Code
Bestell - Nr. / Code
Código / Código

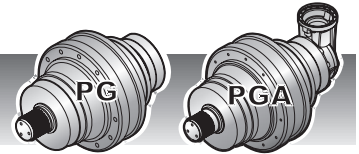

CARICHI RADIALI (Fr)

Nei diagrammi seguenti sono riportati i carichi radiali e i coefficienti K per rapportarli al valore $n_2 \times h$ desiderato.

RADIAL LOADS (Fr)

The following curves show the radial loads and the K factors to obtain the required $n_2 \times h$ value.

RADIALLAST (Fr)

In den nachstehenden Diagrammen ist die Radiallast und der Koeffizient K dargestellt und kann mit dem gewünschten Wert $n_2 \times h$ verglichen werden.

CHARGES RADIALES (Fr)

Dans les diagrammes suivants sont indiqués les charges radiales et les facteurs K de façon à obtenir la valeur $n_2 \times h$ désirée.

CARGAS RADIALES (Fr)

En los siguientes diagramas se indican las cargas radiales y los coeficientes K para obtener el valor requerido $n_2 \times h$.

CARGAS RADIAIS (Fr)

Nos diagramas seguintes são indicadas as cargas radiais e os coeficientes K para obter o valor $n_2 \times h$ desejado.

M

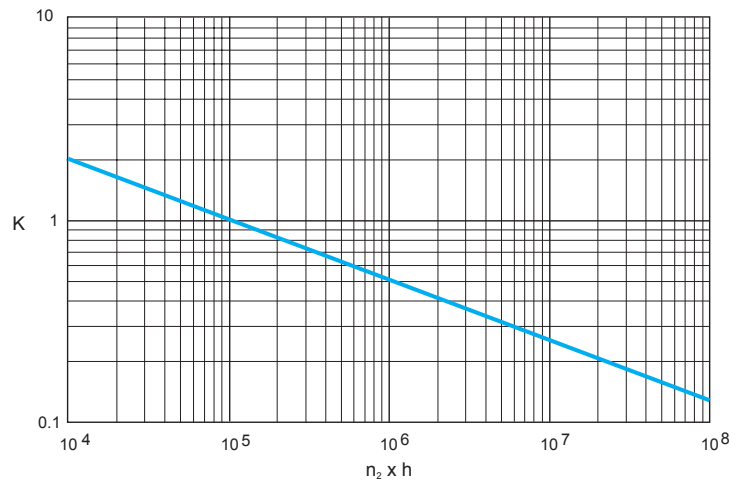
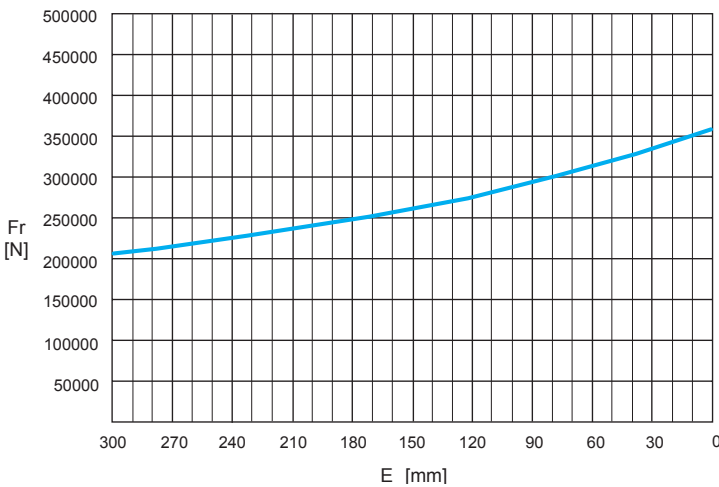

	$n_2 \times h$				
	10^5	10^4	10^6	10^7	10^8
M	Fr		Fr • K		

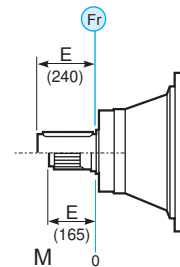

CARICHI ASSIALI (Fa)

I valori dei carichi assiali indicati in tabella sono riferiti alle versioni e alla direzione di applicazione del carico.

AXIAL LOADS (Fa)

The values of the axial loads in the table refer to the output versions and load direction of application.

AXIALLAST (Fa)

Die dargestellten Werte der Axiallast basieren auf der Version und der applizierten Lastrichtung.

CHARGES AXIALES (Fa)

Les valeurs des charges axiales indiquées dans le tableau se réfèrent aux versions et à la direction d'application de la charge.

CARGAS AXIALES (Fa)

Los valores de las cargas axiales indicados en la tabla se refieren a las versiones y a la dirección de aplicación de la carga.

CARGAS AXIAIS (Fa)

Os valores das cargas axiais indicadas na tabela referem-se às versões e à direção de aplicação da carga.

Fa [N]	M	
	75000	←
65250	→	

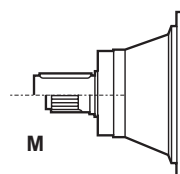



16000

IT EN DE FR ES PT

	i	Mc [kNm]				n _{1max} [min ⁻¹]	Pt [kW]	Kg				
		n ₂ x h	n ₂ x h	n ₂ x h	n ₂ x h			M	P	CPC	F	FS
		10.000	20.000	50.000	100.000							
PG 16001	3.83	236.0	212.5	185.0	171.5	200	109	690	-	-	655	672
	4.40	204.0	183.7	159.9	150.8							
PG 16002	15.15	201.5	178.3	151.8	134.3	1200	67	922	-	-	887	914
	17.40	204.0	183.7	159.9	150.6							
	19.39	147.5	130.5	111.1	98.3							
	22.28	165.3	146.3	124.5	110.2							
	26.40	131.9	116.7	99.3	87.9							
PG 16003	53.85	179.7	159.1	135.3	119.8	2000	47	965	-	-	930	957
	61.87	201.5	178.3	151.7	134.3							
	74.57	175.6	155.4	132.2	117.1							
	83.10	147.5	130.5	111.1	98.3							
	95.46	165.3	146.3	124.5	110.2							
	108.58	146.8	130.0	110.6	97.9							
	124.74	164.6	145.7	124.0	109.8							
	147.84	131.9	116.7	99.3	87.9							
	178.20	131.9	116.7	99.3	87.9							
PG 16004	233.72	157.8	139.8	119.0	105.3	2800	37	980	-	-	945	972
	260.44	147.5	130.5	111.1	98.3							
	326.70	165.3	146.3	124.5	110.2							
	360.64	165.3	146.3	124.5	110.2							
	393.79	165.3	146.3	124.5	110.2							
	429.34	147.5	130.5	111.1	98.3							
	493.23	165.3	146.3	124.5	110.2							
	514.55	164.6	145.7	124.0	109.8							
	572.79	147.4	130.6	111.1	98.6							
	644.49	164.6	145.7	124.0	109.8							
	678.86	131.9	116.7	99.3	87.9							
	748.44	164.6	145.7	124.0	109.8							
	820.29	131.9	116.7	99.3	87.9							
	904.37	143.8	127.3	108.2	96.0							
	1069.20	131.9	116.7	99.3	87.9							
	1291.95	131.9	116.7	99.3	87.9							
PG 16005	1093.71	167.8	148.7	126.7	112.0	2800	30	990	-	-	955	982
	1207.35	175.6	155.4	132.2	117.1							
	1318.32	167.8	148.7	126.7	112.0							
	1400.14	165.3	146.3	124.5	110.2							
	1545.61	165.3	146.3	124.5	110.2							
	1651.22	137.2	121.6	103.4	91.6							
	1722.60	136.0	120.2	102.3	90.4							
	1829.52	164.6	145.7	124.0	109.8							
	2019.60	155.1	137.0	116.6	103.0							
	2205.23	165.3	146.3	124.5	110.2							
	2404.28	147.5	130.5	111.1	98.3							
	2661.12	164.6	145.7	124.0	109.8							
	2762.10	165.3	146.3	124.5	110.2							
	3329.32	165.3	146.3	124.5	109.9							
	4350.31	164.6	145.7	124.0	109.8							
	5051.97	164.6	145.7	124.0	109.8							
	6104.46	143.8	127.3	108.2	96.0							
8720.66	131.9	116.7	99.3	87.9								



	i	Mc [kNm]				n _{1max} [min ⁻¹]	Pt [kW]	Kg				
		n ₂ x h	n ₂ x h	n ₂ x h	n ₂ x h			M	P	CPC	F	FS
		10.000	20.000	50.000	100.000							
PGA 16003	59.55	88.5	71.9	54.6	44.4	2500	42	1005	-	-	970	997
	70.58	99.6	81.0	61.5	50.0							
	81.09	109.8	89.2	67.8	55.1							
	90.48	72.4	65.6	49.8	40.4							
	107.24	84.6	73.8	56.1	45.5							
	123.20	96.0	81.4	61.8	50.2							
PGA 16004	251.31	160.1	130.0	98.7	80.1	2500	35	1038	-	-	1003	1030
	321.72	147.5	130.5	111.1	95.3							
	383.13	164.6	145.7	124.0	109.8							
	445.50	165.3	146.3	124.5	110.2							
	506.71	146.8	130.0	110.6	97.9							
	582.12	164.6	145.7	124.0	109.8							
	689.92	131.9	116.7	99.3	87.9							
	723.87	117.6	104.1	88.6	78.4							
	831.60	131.9	116.7	99.3	87.9							
PGA 16005	1128.60	165.3	146.3	124.5	110.2	2800	27	1023	-	-	988	1015
	1330.99	137.2	121.6	103.4	91.6							
	1417.03	146.8	130.0	110.6	97.9							
	1547.27	146.8	130.0	110.6	97.9							
	1674.75	140.7	131.3	117.5	95.3							
	1777.55	164.6	145.7	124.0	109.8							
	1866.23	147.5	130.5	111.1	98.3							
	2004.14	134.3	118.9	101.1	89.6							
	2226.42	164.6	145.7	124.0	109.8							
	2438.54	146.8	130.0	110.6	97.9							
	2685.38	165.3	146.3	124.5	110.2							
	3054.33	146.8	130.0	110.6	97.9							
	4074.84	164.6	145.7	124.0	109.8							
	4466.00	131.9	116.7	99.3	87.9							
	5821.20	131.9	116.7	99.3	87.9							
	7033.95	131.9	116.7	99.3	87.9							

16000

(n₂ x h = 20.000)

$$M_{\max} = M_c \times 1.6$$

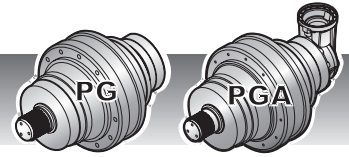

F

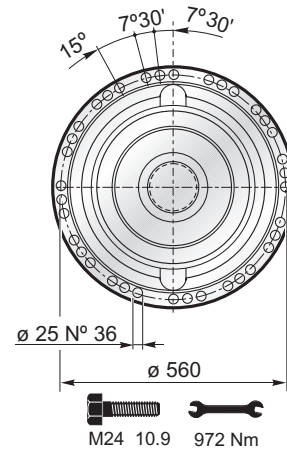
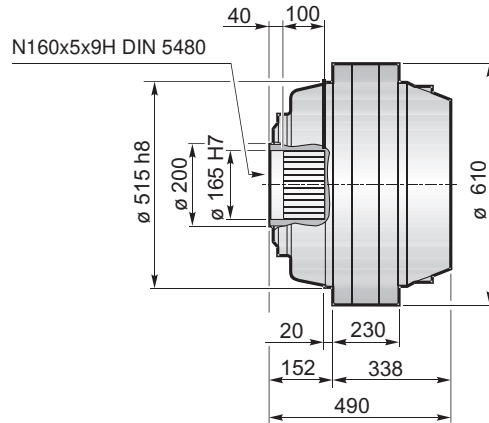

FS

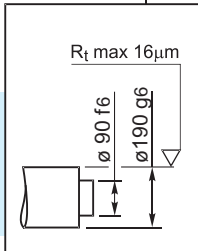
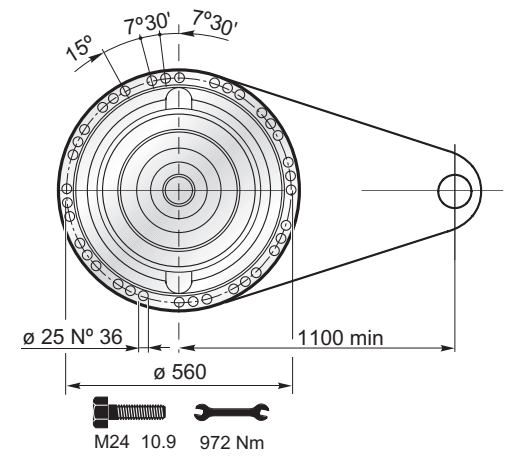
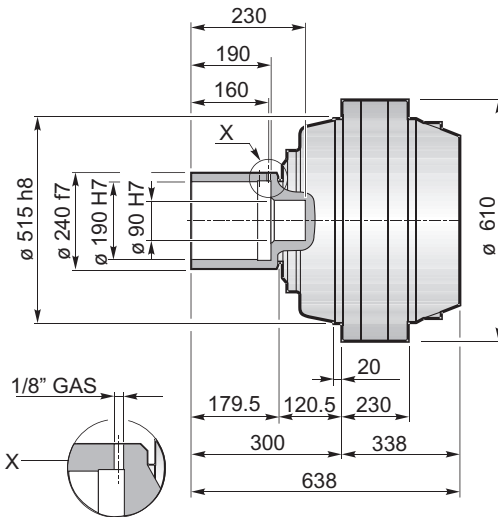

$M_{max} = 236 \text{ kNm}$

La coppia massima indicata è valida solo con calettatori forniti da Planetary Drives
 The maximum torque indicated is valid only with shrink discs supplied by Planetary Drives
 Das dargestellte, maximale Drehmoment gilt nur mit von Planetary Drives gelieferter Schrumpfscheibe
 Le couple maximal indiqué n'est valable qu'avec les frettes de serrage fournis par Planetary Drives
 El momento máximo indicado sólo es válido con discos de contracción suministrados por Planetary Drives
 O torque máximo indicado é válido exclusivamente com discos de contração fornecidos pela Planetary Drives



16000

IT EN DE FR ES PT

PG ...MS						
	A	B	RA	RB	EF	EDF
PG16001	416.5	726.5				
PG16002	637.5	947.5				
PG16003	744.5	1054.5		•		
PG16004	816	1126	•	o	•	
PG16005	877	1187	•			•

PG ...MC						
	A	B	RA	RB	EF	EDF
PG16001	416.5	801.5				
PG16002	637.5	1022.5				
PG16003	744.5	1129.5		•		
PG16004	816	1201	•	o	•	
PG16005	877	1262	•			•

PG ...F						
	A	B	RA	RB	EF	EDF
PG16001	416.5	568.5				
PG16002	637.5	789.5				
PG16003	744.5	896.5		•		
PG16004	816	968	•	o	•	
PG16005	877	1029	•			•

PG ...FS						
	A	B	RA	RB	EF	EDF
PG16001	416.5	716.5				
PG16002	637.5	937.5				
PG16003	744.5	1044.5		•		
PG16004	816	1116	•	o	•	
PG16005	877	1177	•			•

⚠	A	B	•
	A+13.5	B+13.5	o

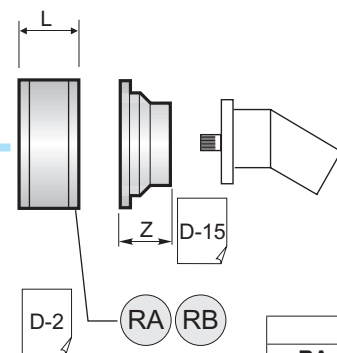
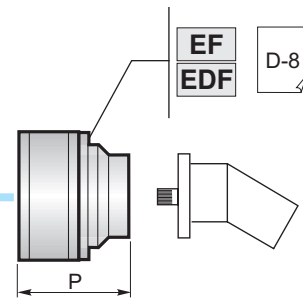
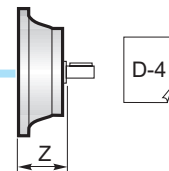
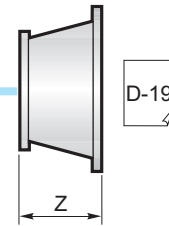
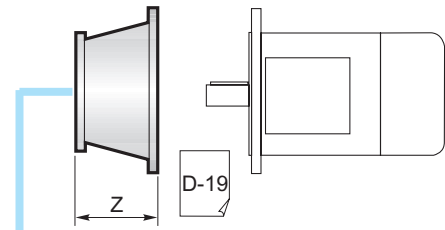

	L
RA	81
RB	125



PGA ...MS						
	A	B	RA	RB	EF	EDF
PGA16003	818.5	315		•		
PGA16004	879.5	315	•	o	•	
PGA16005	917.5	240	•			•

PGA ...MC						
	A	B	RA	RB	EF	EDF
PGA16003	818.5	315		•		
PGA16004	879.5	315	•	o	•	
PGA16005	917.5	240	•			•

PGA ...F						
	A	B	RA	RB	EF	EDF
PGA16003	818.5	315		•		
PGA16004	879.5	315	•	o	•	
PGA16005	917.5	240	•			•

PGA ...FS						
	A	B	RA	RB	EF	EDF
PGA16003	818.5	315		•		
PGA16004	879.5	315	•	o	•	
PGA16005	917.5	240	•			•



B	•
B+16.5	o

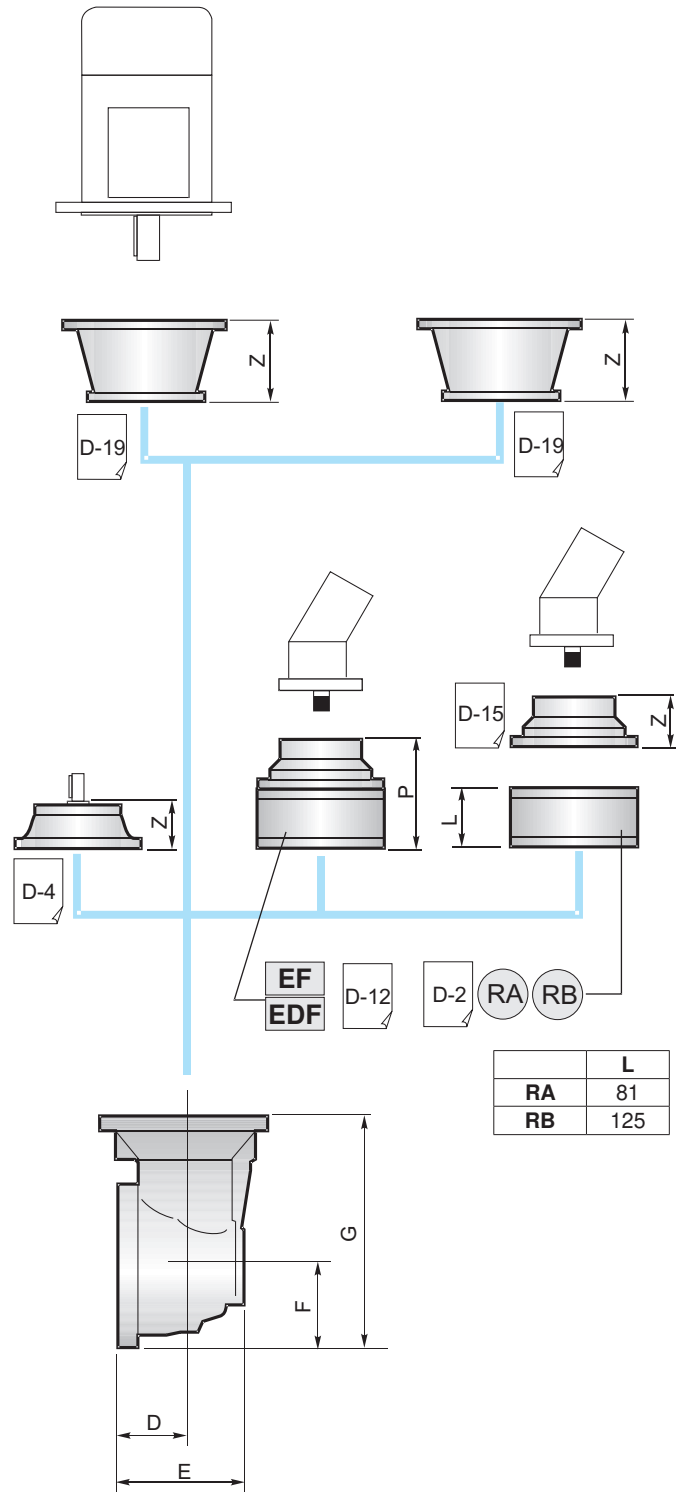

	L
RA	81
RB	125

	D	E	F	G
PGA16003	88	256	235	550
PGA16004	88	256	235	550
PGA16005	88	164	140	380

16000

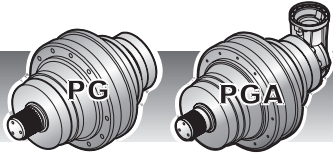

16000

IT EN DE FR ES PT

BS Boccola scanalata / Splined bushing
Innenverzähnte Buchse / Moyeu cannelé
Casquillo ranurado / Bucha estriada

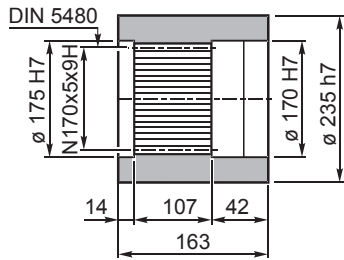

Materiale / Material
Material / Matière
Material / Material
UNI C40
SAE 1040
DIN Ck40

Codice / Code
Bestell - Nr. / Code
Código / Código

FF Fondello di arresto / Stop bottom plate
Endscheibe / Bouchon de fermeture
Tapón de detención / Fundo de batente

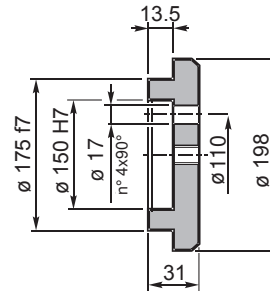

Codice / Code
Bestell - Nr. / Code
Código / Código

FL Flangia / Flange
Flansch / Bride
Brida / Flange

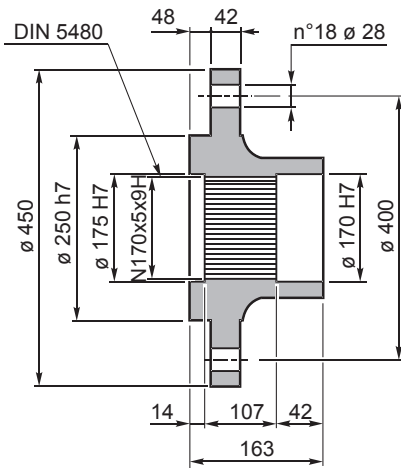

Codice / Code
Bestell - Nr. / Code
Código / Código

GA Giunto di attrito / Shrink disc
Schrumpfscheibe / Frette de serrage
Disco de contracción / Disco de contração

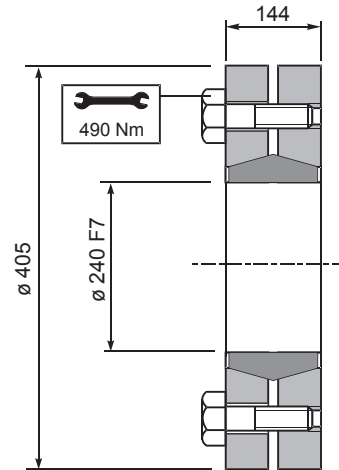

Coppia max.
Max. torque
Max. Drehmoment
Couple max.
Momento máx.
Torque máx.

236 kNm

Codice / Code
Bestell - Nr. / Code
Código / Código

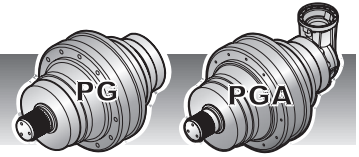

CARICHI RADIALI (Fr)

Nei diagrammi seguenti sono riportati i carichi radiali e i coefficienti K per rapportarli al valore $n_2 \times h$ desiderato.

RADIAL LOADS (Fr)

The following curves show the radial loads and the K factors to obtain the required $n_2 \times h$ value.

RADIALLAST (Fr)

In den nachstehenden Diagrammen ist die Radiallast und der Koeffizient K dargestellt und kann mit dem gewünschten Wert $n_2 \times h$ verglichen werden.

CHARGES RADIALES (Fr)

Dans les diagrammes suivants sont indiqués les charges radiales et les facteurs K de façon à obtenir la valeur $n_2 \times h$ désirée.

CARGAS RADIALES (Fr)

En los siguientes diagramas se indican las cargas radiales y los coeficientes K para obtener el valor requerido $n_2 \times h$.

CARGAS RADIAIS (Fr)

Nos diagramas seguintes são indicadas as cargas radiais e os coeficientes K para obter o valor $n_2 \times h$ desejado.

M

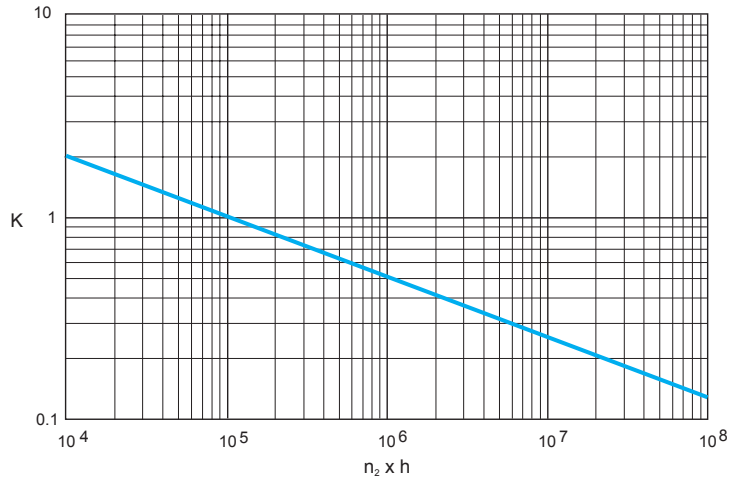
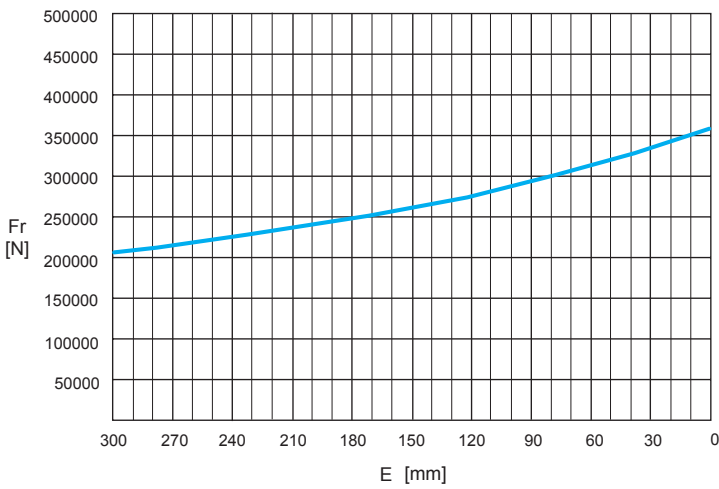

	$n_2 \times h$				
	10^5	10^4	10^6	10^7	10^8
M	Fr		Fr • K		

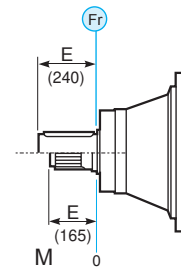

CARICHI ASSIALI (Fa)

I valori dei carichi assiali indicati in tabella sono riferiti alle versioni e alla direzione di applicazione del carico.

AXIAL LOADS (Fa)

The values of the axial loads in the table refer to the output versions and load direction of application.

AXIALLAST (Fa)

Die dargestellten Werte der Axiallast basieren auf der Version und der applizierten Lastrichtung.

CHARGES AXIALES (Fa)

Les valeurs des charges axiales indiquées dans le tableau se réfèrent aux versions et à la direction d'application de la charge.

CARGAS AXIALES (Fa)

Los valores de las cargas axiales indicados en la tabla se refieren a las versiones y a la dirección de aplicación de la carga.

CARGAS AXIAIS (Fa)

Os valores das cargas axiais indicadas na tabela referem-se às versões e à direção de aplicação da carga.

Fa	M	
	[N]	75000
	65250	→

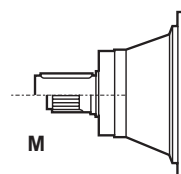



21000/21000H

IT EN DE FR ES PT

	i	Mc [kNm]				n _{1max} [min ⁻¹]	Pt [kW]	Kg				
		n ₂ x h	n ₂ x h	n ₂ x h	n ₂ x h			M	P	CPC	F	FS
		10.000	20.000	50.000	100.000							
PG 21001	3.68	279.3	238.2	181.0	147.0	200	133	930	-	-	880	1002
	4.94	201.1	181.1	157.6	142.0							
PG 21002	H 14.08	222.2	196.7	167.4	147.0	1200	72	1124 (1144-H)	-	-	1074 (1094-H)	1096 (1116-H)
	19.54	201.1	181.1	157.6	142.0							
	25.01	181.9	161.0	137.0	121.3							
	29.64	145.1	128.4	109.3	96.7							
PG 21003	H 56.32	222.2	196.7	167.4	147.0	2000	52	1184 (1261-H)	-	-	1134 (1211-H)	1156 (1233-H)
	H 73.22	222.2	196.7	167.4	147.0							
	83.72	193.1	170.9	145.5	128.8							
	H 98.28	201.1	181.1	157.6	142.0							
	107.18	181.9	161.0	137.0	121.3							
	H 118.13	201.1	181.1	157.6	142.0							
	140.05	181.1	160.3	136.4	120.8							
	165.98	145.1	128.4	109.3	96.7							
200.07	145.1	128.4	109.3	96.7								
PG 21004	H 249.42	183.2	162.2	137.9	122.2	2800	40	1200 (1288-H)	-	-	1150 (1238-H)	1177 (1265-H)
	H 334.82	201.1	181.1	157.6	142.0							
	H 389.71	172.4	152.6	129.9	114.9							
	H 433.14	201.1	181.1	157.6	142.0							
	H 491.42	201.1	181.1	157.6	142.0							
	529.07	181.1	160.3	136.4	120.8							
	H 570.05	201.1	181.1	157.6	142.0							
	625.97	142.1	125.7	107.0	94.8							
	H 685.16	201.1	181.1	157.6	142.0							
	723.59	181.1	160.3	136.4	120.8							
	793.14	129.1	114.2	97.1	86.2							
	H 826.91	201.1	179.4	152.8	135.1							
	920.96	145.1	128.4	109.3	96.7							
	1015.36	158.2	140.0	119.1	105.7							
	1200.42	145.1	128.4	109.3	96.7							
	1450.51	145.1	128.4	109.3	96.7							
PG 21005	H 1486.55	201.1	181.1	157.6	142.0	2800	32	1208 (1300-H)	-	-	1158 (1250-H)	1185 (1277-H)
	H 1559.32	201.1	181.1	154.5	136.8							
	H 1675.25	222.2	196.7	167.4	147.0							
	H 1729.88	201.1	181.1	157.6	142.0							
	H 1795.45	201.1	181.1	157.6	142.0							
	H 1856.49	201.1	181.1	157.6	142.0							
	H 1945.45	222.2	196.7	167.4	147.0							
	H 2008.89	201.1	181.1	157.6	142.0							
	H 2105.40	172.4	152.6	129.9	114.9							
	H 2196.48	199.8	176.8	150.5	133.2							
	H 2268.10	201.1	181.1	154.5	136.8							
	2314.39	147.7	130.8	111.3	98.5							
	H 2427.41	201.1	181.1	156.0	138.0							
	2475.87	181.9	161.0	137.0	121.3							
	H 2539.02	201.1	181.1	157.6	142.0							
	H 2654.08	199.8	176.8	150.5	133.2							
	3155.64	201.1	181.1	157.6	142.0							
	H 4132.86	201.1	181.1	157.6	142.0							
	H 5995.12	201.1	179.4	152.8	135.1							
	6853.65	158.2	140.0	119.1	105.7							
8122.84	145.1	128.4	109.3	96.7								



	i	Mc [kNm]				n _{1max} [min ⁻¹]	Pt [kW]	Kg				
		n ₂ x h	n ₂ x h	n ₂ x h	n ₂ x h			M	P	CPC	F	FS
		10.000	20.000	50.000	100.000							
PGA 21003	60.00	88.9	72.3	54.9	44.6	2500	48	1206	-	-	1156	1178
	76.81	105.7	85.9	65.3	53.0							
	91.04	119.1	96.8	73.5	59.7							
	103.04	81.6	71.8	54.5	44.3							
	116.71	91.4	78.3	59.5	48.3							
	138.32	106.7	88.2	67.0	54.4							
PGA 21004	H 232.21	201.1	181.1	141.6	115.1	2500	40	1266 (1343-H)	-	-	1216 (1293-H)	1238 (1315-H)
	H 341.67	204.7	166.2	126.2	102.4							
	390.71	193.1	170.9	138.6	112.5							
	H 458.66	201.1	181.1	155.0	125.9							
	H 551.28	201.1	181.1	157.6	142.0							
	592.80	145.1	128.4	109.3	96.7							
	653.56	181.1	160.3	136.4	120.8							
	774.59	145.1	128.4	109.3	96.7							
	933.66	145.1	128.4	109.3	96.7							
PGA 21005	H 1120.11	220.9	179.5	136.4	110.8	2800	31	1246 (1334-H)	-	-	1196 (1284-H)	1218 (1306-H)
	H 1264.64	199.8	176.8	148.5	120.6							
	1398.76	181.9	161.0	137.0	121.3							
	H 1496.32	201.1	181.1	157.6	135.7							
	1527.32	181.9	161.0	137.0	121.3							
	H 1697.64	201.1	181.1	157.6	142.0							
	H 1756.74	146.7	136.8	121.5	98.6							
	1827.71	181.1	160.3	136.4	120.8							
	H 1969.26	201.1	181.1	157.6	142.0							
	2204.48	178.5	161.0	137.0	115.5							
	2267.53	147.7	130.8	111.3	98.5							
	H 2358.23	189.2	176.5	149.3	121.1							
	2499.66	181.1	160.3	136.4	120.8							
	H 2675.52	201.1	181.1	157.6	132.3							
	H 3103.61	201.1	181.1	157.6	142.0							
	3501.23	162.2	143.7	122.2	108.4							
	H 4502.08	201.1	179.4	152.8	135.1							
	5528.05	158.2	140.0	119.1	105.7							
7897.21	145.1	128.4	109.3	96.7								

21000

(n₂ x h = 20.000)

$$M_{max} = M_C \times 1.7$$

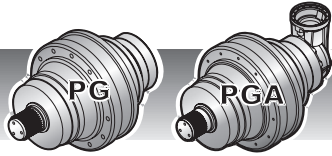

21000/21000H

IT EN DE FR ES PT

MS

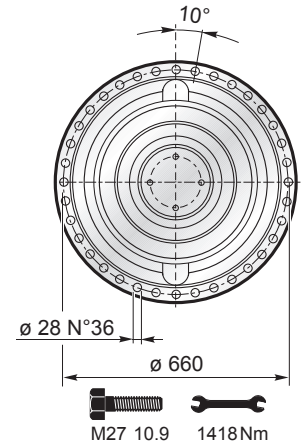
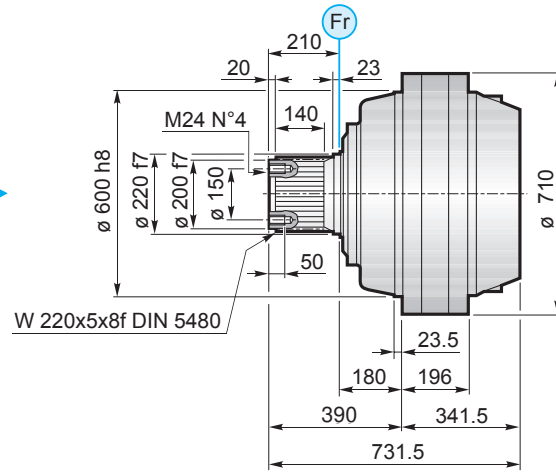

MC

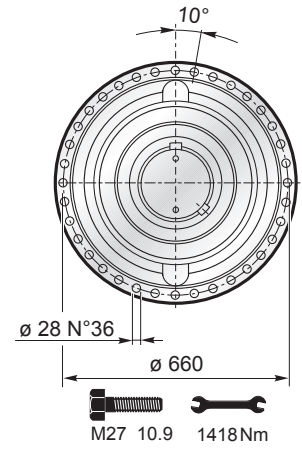
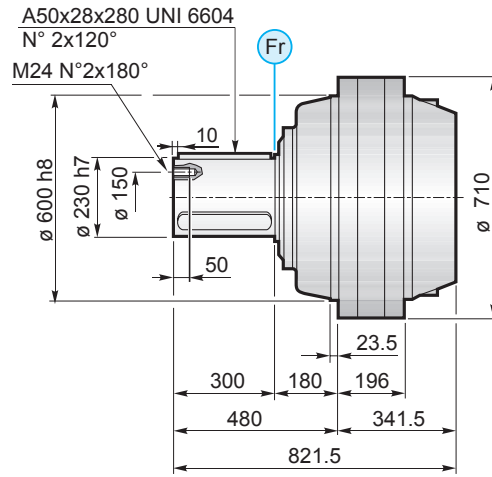

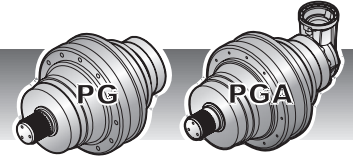

F

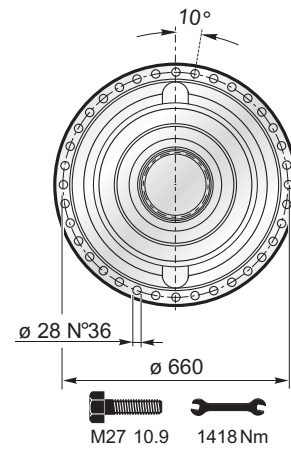
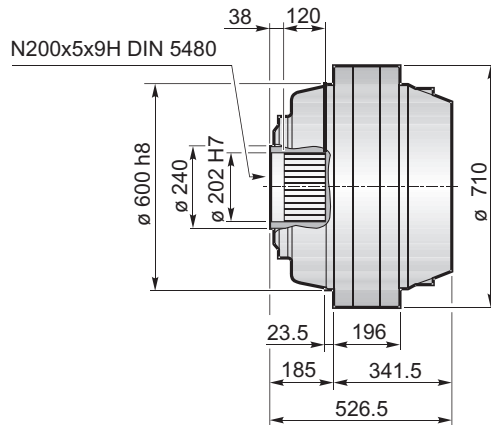

FS

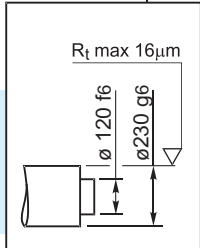
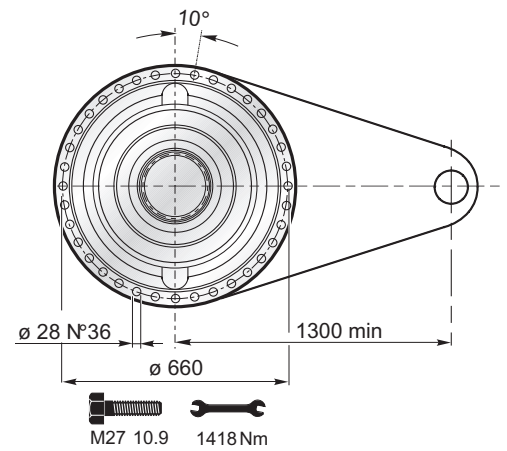
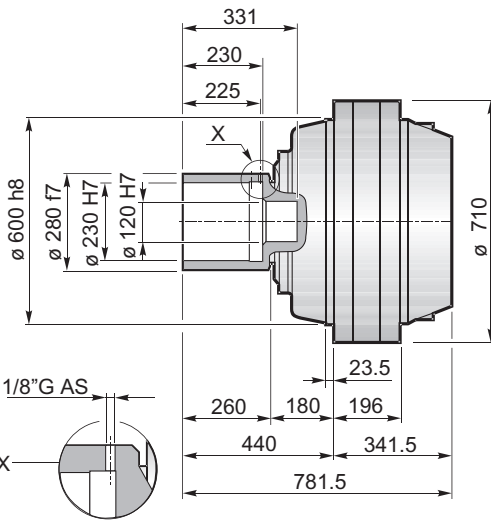

$M_{max} = 407 \text{ kNm}$

La coppia massima indicata è valida solo con calettatori forniti da Planetary Drives
 The maximum torque indicated is valid only with shrink discs supplied by Planetary Drives
 Das dargestellte, maximale Drehmoment gilt nur mit von Planetary Drives gelieferter Schrumpfscheibe
 Le couple maximal indiqué n'est valable qu'avec les frettes de serrage fournis par Planetary Drives
 El momento máximo indicado sólo es válido con discos de contracción suministrados por Planetary Drives
 O torque máximo indicado é válido exclusivamente com discos de contração fornecidos pela Planetary Drives



21000/21000H

IT EN DE FR ES PT

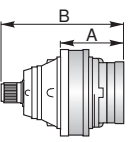
	PG ...MS						Vers. H					
	A	B	RA	RB	EF	EDF	A	B	RA	RB	EF	EDF
PG21001	341.5	731.5					341.5	731.5				
PG21002	562.5	952.5					607.5	997.5				
PG21003	669.5	1059.5		•			789.5	1179.5		•		
PG21004	741	1131	•	o	•		883.5	1273.5		•	o	•
PG21005	802	1192	•			•	943	1333	•	o	•	

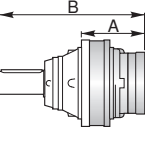
	PG ...MC						Vers. H					
	A	B	RA	RB	EF	EDF	A	B	RA	RB	EF	EDF
PG21001	341.5	821.5					341.5	821.5				
PG21002	562.5	1042.5					607.5	1087.5				
PG21003	669.5	1149.5		•			789.5	1269.5		•		
PG21004	741	1221	•	o	•		883.5	1363.5	•	o	•	
PG21005	802	1282	•			•	943	1423	•			•

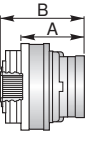
	PG ...F						Vers. H					
	A	B	RA	RB	EF	EDF	A	B	RA	RB	EF	EDF
PG21001	341.5	526.5					341.5	526.5				
PG21002	562.5	747.5					607.5	792.5				
PG21003	669.5	854.5		•			789.5	974.5		•		
PG21004	741	926	•	o	•		883.5	1068.5	•	o	•	
PG21005	802	987	•			•	943	1128	•			•

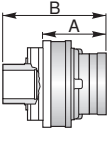
	PG ...FS						Vers. H					
	A	B	RA	RB	EF	EDF	A	B	RA	RB	EF	EDF
PG21001	341.5	781.5					341.5	781.5				
PG21002	562.5	1002.5					607.5	1047.5				
PG21003	669.5	1109.5		•			789.5	1229.5		•		
PG21004	741	1181	•	o	•		883.5	1323.5	•	o	•	
PG21005	802	1242	•			•	943	1383	•			•



A	B	•
A+13.5	B+13.5	o

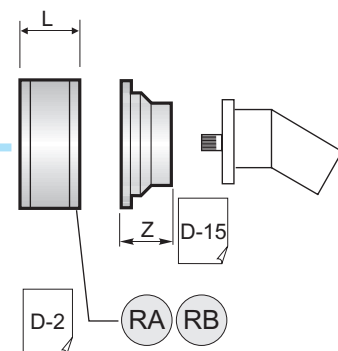
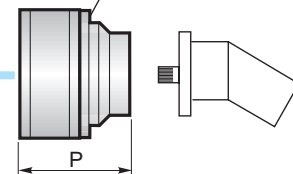
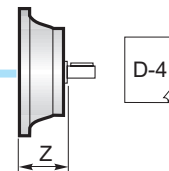
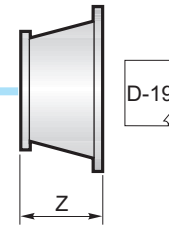
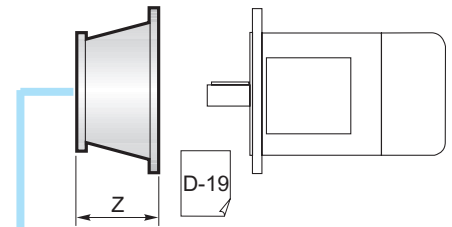

	L
RA	81
RB	125



	PGA ...MS						Vers. H				
	A	B	RA	RB	EF	EDF	A	B	RA	RB	EF
PGA21003	818.5	315		•							
PGA21004	832.5	315	•	o	•		869,5	315		•	
PGA21005	917.5	240	•			•	971,5	240	•	o	•

	PGA ...MC						Vers. H				
	A	B	RA	RB	EF	EDF	A	B	RA	RB	EF
PGA21003	818.5	315		•							
PGA21004	832.5	315	•	o	•		869,5	1349.5		•	
PGA21005	917.5	240	•			•	971,5	1451.5	•	o	•

	PGA ...F						Vers. H				
	A	B	RA	RB	EF	EDF	A	B	RA	RB	EF
PGA21003	818.5	315		•							
PGA21004	832.5	315	•	o	•		869,5	315		•	
PGA21005	917.5	240	•			•	971,5	240	•	o	•

	PGA ...FS						Vers. H				
	A	B	RA	RB	EF	EDF	A	B	RA	RB	EF
PGA21003	818.5	315		•							
PGA21004	832.5	315	•	o	•		869,5	315		•	
PGA21005	917.5	240	•			•	971,5	240	•	o	•



B	•
B+16.5	o

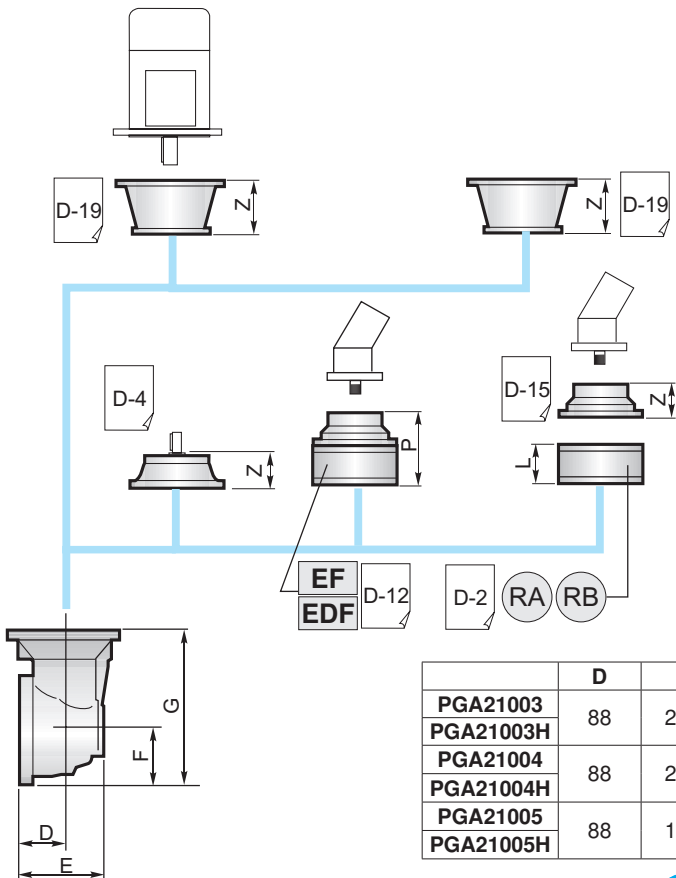

	L
RA	81
RB	125

	D	E	F	G
PGA21003	88	256	235	550
PGA21003H	88	256	235	550
PGA21004	88	256	235	550
PGA21004H	88	256	235	550
PGA21005	88	164	140	380
PGA21005H	88	164	140	380

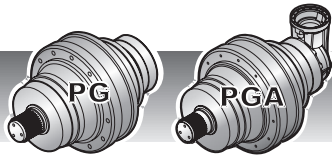

21000/21000H

IT EN DE FR ES PT

BS Boccia scanalata / Splined bushing
Innenverzahnte Buchse / Moyeu cannelé
Casquillo ranurado / Bucha estriada

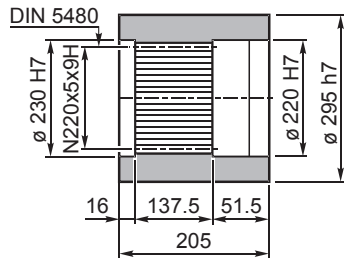

Materiale / Material
Material / Matière
Material / Material
UNI C40
SAE 1040
DIN Ck40

Codice / Code
Bestell - Nr. / Code
Código / Código

FF Fondello di arresto / Stop bottom plate
Endscheibe / Bouchon de fermeture
Tapón de detención / Fundo de batente

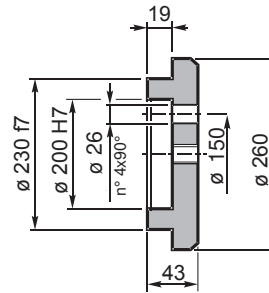

Codice / Code
Bestell - Nr. / Code
Código / Código

FL Flangia / Flange
Flansch / Bride
Brida / Flange

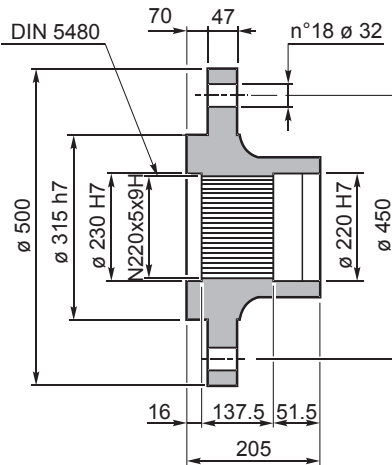

Codice / Code
Bestell - Nr. / Code
Código / Código

GA Giunto di attrito / Shrink disc
Schrumpfscheibe / Frette de serrage
Disco de contracción / Disco de contração

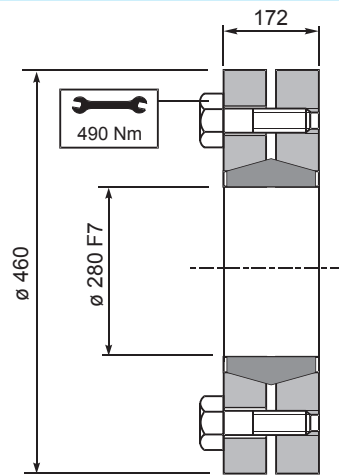

Coppia max.
Max. torque
Max. Drehmoment
Couple max.
Momento máx.
Torque máx.

407 kNm

Codice / Code
Bestell - Nr. / Code
Código / Código

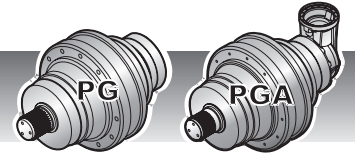

CARICHI RADIALI (Fr)

Nei diagrammi seguenti sono riportati i carichi radiali e i coefficienti K per rapportarli al valore $n_2 \times h$ desiderato.

RADIAL LOADS (Fr)

The following curves show the radial loads and the K factors to obtain the required $n_2 \times h$ value.

RADIALLAST (Fr)

In den nachstehenden Diagrammen ist die Radiallast und der Koeffizient K dargestellt und kann mit dem gewünschten Wert $n_2 \times h$ verglichen werden.

CHARGES RADIALES (Fr)

Dans les diagrammes suivants sont indiqués les charges radiales et les facteurs K de façon à obtenir la valeur $n_2 \times h$ désirée.

CARGAS RADIALES (Fr)

En los siguientes diagramas se indican las cargas radiales y los coeficientes K para obtener el valor requerido $n_2 \times h$.

CARGAS RADIAIS (Fr)

Nos diagramas seguintes são indicadas as cargas radiais e os coeficientes K para obter o valor $n_2 \times h$ desejado.

M

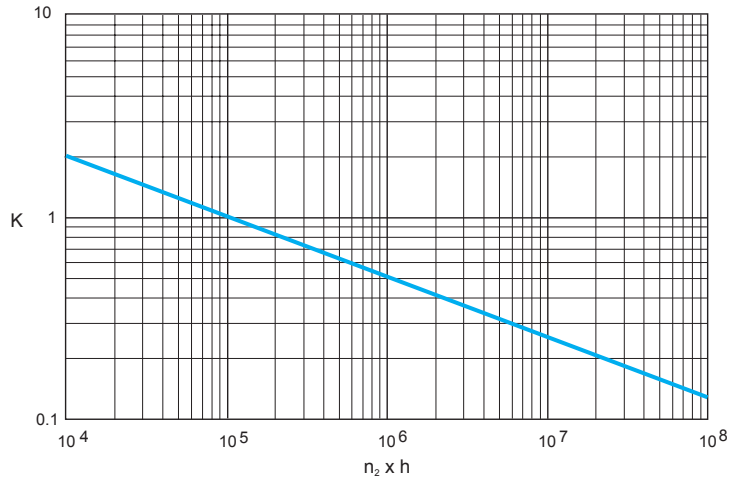
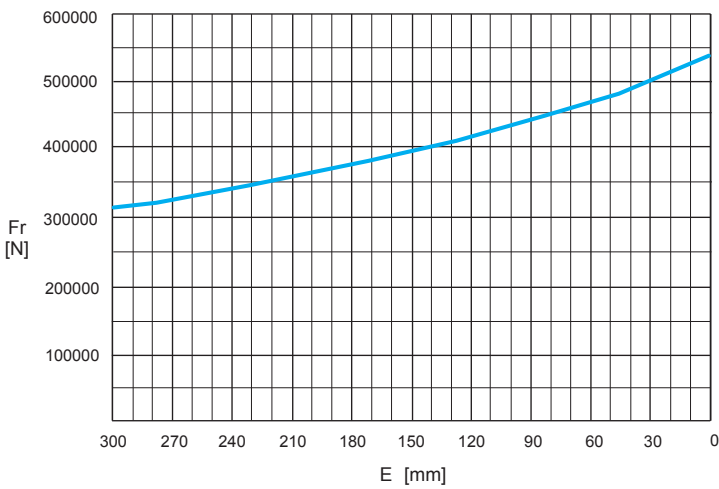

	$n_2 \times h$				
	10^5	10^4	10^6	10^7	10^8
M	Fr		Fr • K		

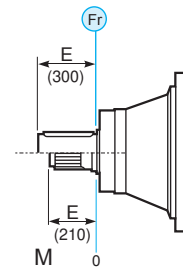

CARICHI ASSIALI (Fa)

I valori dei carichi assiali indicati in tabella sono riferiti alle versioni e alla direzione di applicazione del carico.

AXIAL LOADS (Fa)

The values of the axial loads in the table refer to the output versions and load direction of application.

AXIALLAST (Fa)

Die dargestellten Werte der Axiallast basieren auf der Version und der applizierten Lastrichtung.

CHARGES AXIALES (Fa)

Les valeurs des charges axiales indiquées dans le tableau se réfèrent aux versions et à la direction d'application de la charge.

CARGAS AXIALES (Fa)

Los valores de las cargas axiales indicados en la tabla se refieren a las versiones y a la dirección de aplicación de la carga.

CARGAS AXIAIS (Fa)

Os valores das cargas axiais indicadas na tabela referem-se às versões e à direção de aplicação da carga.

Fa	M	
	[N]	113600
	113600	→

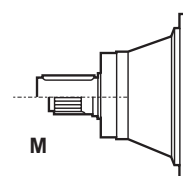



26000

IT EN DE FR ES PT

	i	Mc [kNm]				n _{1max} [min ⁻¹]	Pt [kW]	Kg				
		n ₂ x h	n ₂ x h	n ₂ x h	n ₂ x h			M	P	CPC	F	FS
		10.000	20.000	50.000	100.000							
PG 26001	3.68	320.6	288.7	251.3	220.5	200	136	980	-	-	920	958
	4.94	230.9	207.9	181.0	173.1							
PG 26002	14.88	317.4	280.9	239.1	211.6	1200	83	1303	-	-	1243	1281
	18.83	253.3	224.2	190.8	168.9							
	25.28	230.9	207.9	181.0	173.1							
PG 26003	59.52	302.5	267.7	227.9	201.7	2000	60	1419	-	-	1359	1397
	75.33	253.3	224.2	190.8	168.9							
	79.90	230.9	207.9	181.0	173.1							
	97.93	253.3	224.2	190.8	168.9							
	103.87	230.9	207.9	181.0	173.1							
	117.71	219.1	193.9	165.1	146.1							
	131.46	230.9	207.9	181.0	173.1							
	158.01	230.9	207.9	181.0	173.1							
PG 26004	218.24	210.0	185.9	158.1	140.1	2800	46	1446	-	-	1386	1424
	276.22	253.3	224.2	190.8	168.9							
	333.61	232.8	206.1	175.3	155.3							
	380.85	230.9	207.9	181.0	173.1							
	433.70	253.3	224.2	190.8	168.9							
	489.66	253.3	224.2	190.8	168.9							
	521.27	219.1	193.9	165.1	146.1							
	579.36	230.9	207.9	181.0	173.1							
	624.21	230.0	203.6	173.3	153.3							
	682.69	219.1	193.9	165.1	146.1							
	724.09	230.0	203.6	173.3	153.3							
	790.04	230.9	207.9	181.0	173.1							
	873.90	212.1	187.7	159.9	141.4							
	920.23	221.4	195.9	166.9	147.6							
	1106.05	230.9	207.9	181.0	171.7							
PG 26005	1139.39	253.3	224.2	190.8	168.9	2800	40	1458	-	-	1398	1436
	1260.31	232.8	206.1	175.3	155.3							
	1356.53	253.3	224.2	190.8	168.9							
	1427.12	253.3	224.2	190.8	168.9							
	1571.02	230.9	207.9	181.0	173.1							
	1691.83	230.9	207.9	181.0	173.1							
	1757.78	230.9	207.9	180.7	159.8							
	1849.81	253.3	224.2	190.8	168.9							
	1967.74	230.9	207.9	181.0	173.1							
	2085.70	230.9	207.9	181.0	173.1							
	2188.69	230.9	207.9	181.0	173.1							
	2240.76	253.3	224.2	190.8	168.9							
	2313.83	230.9	207.9	181.0	173.1							
	2401.53	230.9	207.9	181.0	173.1							
	2483.17	230.9	207.9	181.0	173.1							
	2602.17	253.3	224.2	190.8	168.9							
	3144.29	253.3	224.2	190.8	168.9							
	4200.36	230.9	207.9	181.0	173.1							
	5073.16	230.9	207.9	181.0	173.1							
	5973.57	202.1	178.9	152.4	134.7							
8018.87	230.9	207.9	181.0	171.7								



	i	Mc [kNm]				n _{1max} [min ⁻¹]	Pt [kW]	Kg				
		n ₂ x h	n ₂ x h	n ₂ x h	n ₂ x h			M	P	CPC	F	FS
		10.000	20.000	50.000	100.000							
PGA 26004	182.81	194.0	157.6	119.8	97.3	2500	40	1529	-	-	1469	1507
	231.38	228.8	185.9	141.3	114.8							
	300.79	253.3	223.3	169.7	137.9							
	351.55	208.8	169.5	128.7	104.5							
	383.44	230.0	203.6	173.3	153.3							
	457.01	250.9	203.7	154.7	125.6							
	485.31	230.9	207.9	181.0	173.1							
	549.29	219.1	193.9	165.1	142.8							
	613.49	230.9	207.9	181.0	154.3							
	737.37	230.9	207.9	181.0	173.1							
PGA 26005	910.58	191.1	155.3	118.0	95.8	2800	35	1500	-	-	1440	1478
	1012.06	205.8	167.2	127.0	103.2							
	1240.46	237.3	192.8	146.5	119.0							
	1380.08	214.7	190.0	157.8	128.2							
	1498.22	253.3	220.0	167.2	135.8							
	1547.08	230.9	207.9	171.0	138.9							
	1691.54	253.3	224.2	182.0	147.9							
	1746.70	230.9	207.9	181.0	151.2							
	1909.93	230.0	203.6	173.3	153.3							
	2001.43	230.9	207.9	181.0	166.3							
	2156.37	230.0	203.6	173.3	153.3							
	2270.71	230.9	207.9	181.0	173.1							
	2358.40	219.1	193.9	165.1	146.1							
	2501.39	230.0	203.6	173.3	153.3							
	2634.02	230.9	207.9	181.0	173.1							
	2846.34	202.1	178.9	152.4	134.7							
	3398.49	230.0	203.6	173.3	153.3							
	4151.28	230.9	207.9	181.0	173.1							
	5010.17	221.4	195.9	166.9	147.6							
	6021.84	230.9	207.9	181.0	171.7							

(n₂ x h = 20.000)

$$M_{\max} = M_c \times 1.9$$

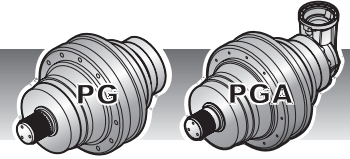

F

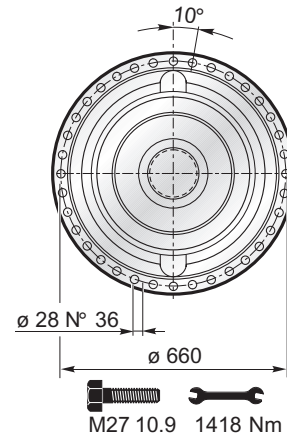
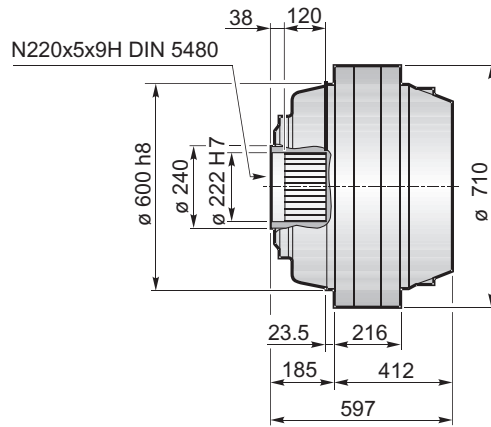

FS

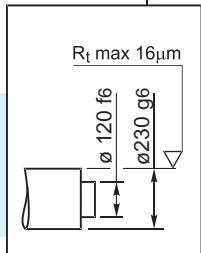
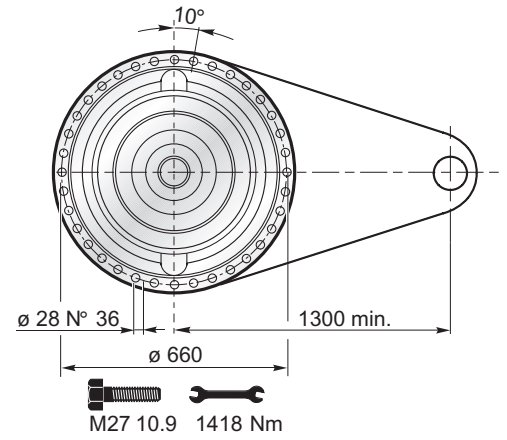
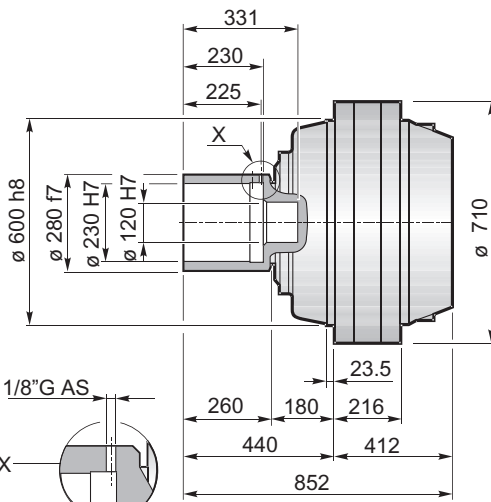

$M_{max} = 407 \text{ kNm}$

La coppia massima indicata è valida solo con calettatori forniti da Planetary Drives
 The maximum torque indicated is valid only with shrink discs supplied by Planetary Drives
 Das dargestellte, maximale Drehmoment gilt nur mit von Planetary Drives gelieferter Schrumpfscheibe
 Le couple maximal indiqué n'est valable qu'avec les frettes de serrage fournis par Planetary Drives
 El momento máximo indicado sólo es válido con discos de contracción suministrados por Planetary Drives
 O torque máximo indicado é válido exclusivamente com discos de contração fornecidos pela Planetary Drives





26000

IT EN DE FR ES PT

PG ...MS						
	A	B	RA	RB	EF	EDF
PG26001	412	802				
PG26002	667	1057				
PG26003	849	1239				
PG26004	943	1333		•		
PG26005	1002.5	1392.5	•	o	•	

PG ...MC						
	A	B	RA	RB	EF	EDF
PG26001	412	892				
PG26002	667	1147				
PG26003	849	1329				
PG26004	943	1423		•		
PG26005	1002.5	1482.5	•	o	•	

PG ...F						
	A	B	RA	RB	EF	EDF
PG26001	412	597				
PG26002	667	852				
PG26003	849	1034				
PG26004	943	1128		•		
PG26005	1002.5	1187.5	•	o	•	

PG ...FS						
	A	B	RA	RB	EF	EDF
PG26001	412	852				
PG26002	667	1107				
PG26003	849	1289				
PG26004	943	1383		•		
PG26005	1002.5	1442.5	•	o	•	

!	A	B	•
	A+13.5	B+13.5	o

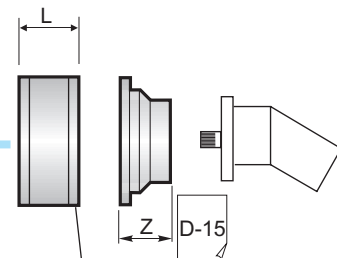
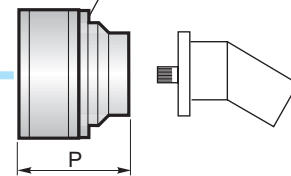
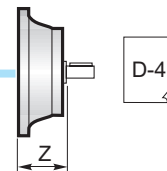
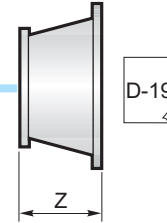
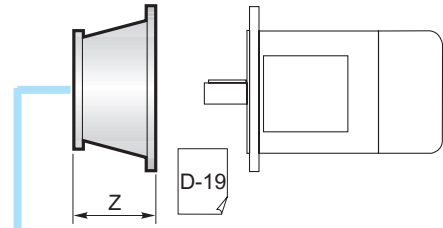

	L
RA	81
RB	125



		PGA ...MS					
		A	B	RA	RB	EF	EDF
	PGA26004	929	315		•		
	PGA26005	1031	240	•	o	•	

		PGA ...MC					
		A	B	RA	RB	EF	EDF
	PGA26004	929	315		•		
	PGA26005	1031	240	•	o	•	

		PGA ...F					
		A	B	RA	RB	EF	EDF
	PGA26004	929	315		•		
	PGA26005	1031	240	•	o	•	

		PGA ...FS					
		A	B	RA	RB	EF	EDF
	PGA26004	929	315		•		
	PGA26005	1031	240	•	o	•	

⚠	B	•
	B+16.5	o

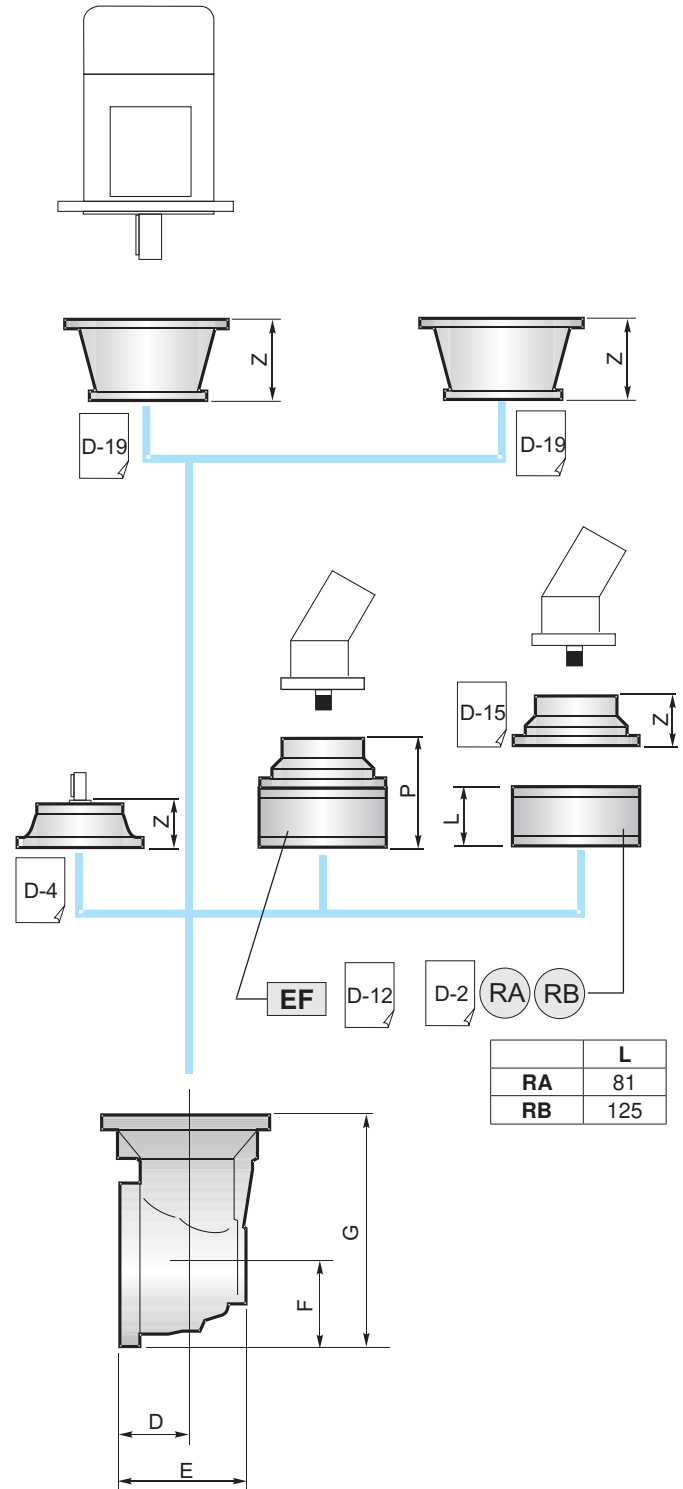

	L
RA	81
RB	125

	D	E	F	G
PGA26004	88	256	235	550
PGA26005	88	164	140	380

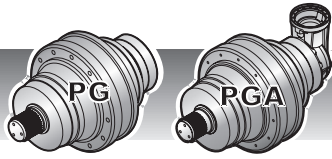

26000

IT EN DE FR ES PT

GA Giunto di attrito / Shrink disc
Schrumpfscheibe / Frette de serrage
Disco de contracción / Disco de contração

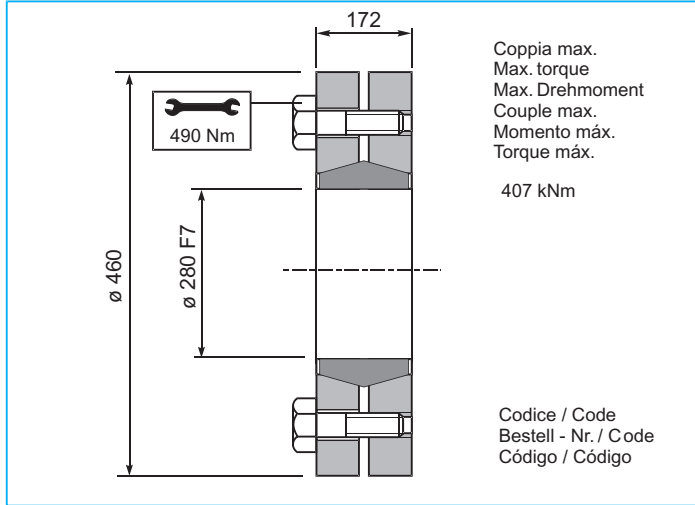

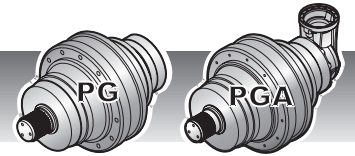

CARICHI RADIALI (Fr)

Nei diagrammi seguenti sono riportati i carichi radiali e i coefficienti K per rapportarli al valore $n_2 \times h$ desiderato.

RADIAL LOADS (Fr)

The following curves show the radial loads and the K factors to obtain the required $n_2 \times h$ value.

RADIALLAST (Fr)

In den nachstehenden Diagrammen ist die Radiallast und der Koeffizient K dargestellt und kann mit dem gewünschten Wert $n_2 \times h$ verglichen werden.

CHARGES RADIALES (Fr)

Dans les diagrammes suivants sont indiqués les charges radiales et les facteurs K de façon à obtenir la valeur $n_2 \times h$ désirée.

CARGAS RADIALES (Fr)

En los siguientes diagramas se indican las cargas radiales y los coeficientes K para obtener el valor requerido $n_2 \times h$.

CARGAS RADIAIS (Fr)

Nos diagramas seguintes são indicadas as cargas radiais e os coeficientes K para obter o valor $n_2 \times h$ desejado.

M

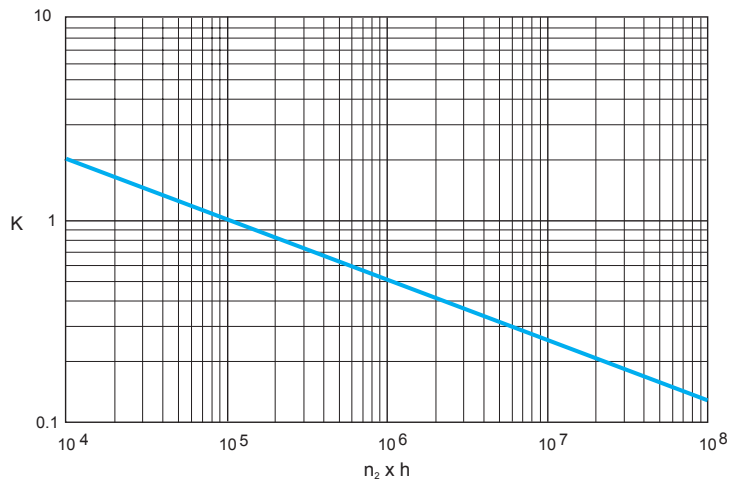
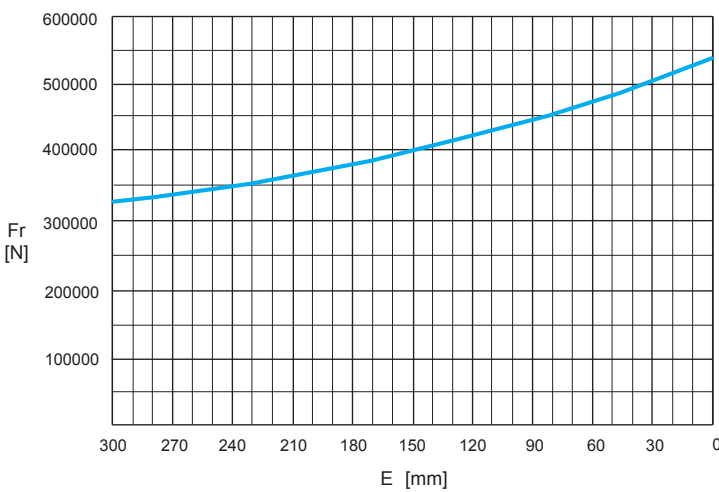

	$n_2 \times h$				
	10^5	10^4	10^6	10^7	10^8
M	Fr		Fr • K		

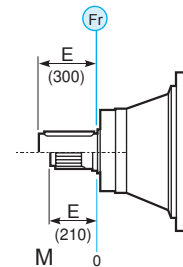

CARICHI ASSIALI (Fa)

I valori dei carichi assiali indicati in tabella sono riferiti alle versioni e alla direzione di applicazione del carico.

AXIAL LOADS (Fa)

The values of the axial loads in the table refer to the output versions and load direction of application.

AXIALLAST (Fa)

Die dargestellten Werte der Axiallast basieren auf der Version und der applizierten Lastrichtung.

CHARGES AXIALES (Fa)

Les valeurs des charges axiales indiquées dans le tableau se réfèrent aux versions et à la direction d'application de la charge.

CARGAS AXIALES (Fa)

Los valores de las cargas axiales indicados en la tabla se refieren a las versiones y a la dirección de aplicación de la carga.

CARGAS AXIAIS (Fa)

Os valores das cargas axiais indicadas na tabela referem-se às versões e à direção de aplicação da carga.

Fa	M	
	[N]	160500
	113600	→

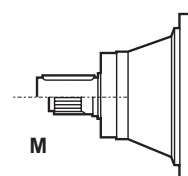



31000/31000H

IT EN DE FR ES PT

	i	Mc [kNm]				n _{1max} [min ⁻¹]	Pt [kW]	Kg				
		n ₂ x h	n ₂ x h	n ₂ x h	n ₂ x h			M	P	CPC	F	FS
		10.000	20.000	50.000	100.000							
PG 31001	3.43	344.1	309.8	269.7	242.9	200	214	1900	-	-	1750	1858
	4.09	404.7	364.4	317.2	285.5							
	5.25	302.9	272.7	237.4	222.5							
PG 31002	H 14.03	344.1	309.8	269.7	242.9	750	110	2208 (2280-H)	-	-	2058 (2130-H)	2166 (2238-H)
	16.54	346.3	306.5	260.8	230.9							
	H 18.01	344.1	309.8	269.7	242.9							
	21.23	302.9	272.7	237.4	222.5							
	H 25.48	340.1	306.2	266.6	254.8							
	29.64	145.1	128.4	109.3	96.7							
PG 31003	H 56.11	344.1	309.8	264.6	234.2	1500	81	2382 (2464-H)	-	-	2232 (2314-H)	2340 (2422-H)
	66.15	330.0	292.1	248.6	220.0							
	H 72.03	344.1	309.8	269.7	242.9							
	84.74	344.1	309.8	269.7	242.9							
	107.47	302.9	272.7	237.4	222.5							
	H 129.71	302.9	272.7	237.4	222.5							
	139.71	302.9	272.7	237.4	222.5							
	167.92	293.6	259.9	221.2	195.7							
PG 31004	H 199.52	344.1	307.7	261.8	231.8	2800	65	2402 (2514-H)	-	-	2252 (2359-H)	2360 (2467-H)
	H 256.11	344.1	309.8	269.7	242.9							
	H 308.70	344.1	309.8	269.7	242.9							
	394.06	302.9	272.7	237.4	222.5							
	H 433.06	302.9	272.7	237.4	222.5							
	488.86	302.9	272.7	236.1	208.9							
	H 555.88	302.9	272.7	237.4	222.5							
	618.72	302.9	272.7	237.4	222.5							
	698.56	302.9	272.7	237.4	222.5							
	743.66	293.6	259.9	221.2	195.7							
	839.61	293.6	259.9	221.2	195.7							
	973.95	293.6	259.9	221.2	195.7							
	PG 31005	H 1154.57	346.1	306.4	260.7							
H 1273.39		344.1	309.8	269.7	242.9							
H 1391.67		346.1	306.4	260.7	230.7							
1529.06		302.9	272.7	236.1	208.9							
H 1594.95		344.1	309.8	269.7	242.9							
1669.60		302.9	272.7	236.1	208.9							
H 1743.10		346.1	306.4	260.7	230.7							
1846.79		302.9	272.7	236.1	208.9							
1935.27		302.9	272.7	237.4	222.5							
H 2024.24		346.1	306.4	260.7	230.7							
2113.14		302.9	272.7	237.4	222.5							
H 2277.65		307.1	271.8	231.1	204.8							
2364.35		302.9	270.7	230.6	203.9							
2525.76		302.9	272.7	236.1	208.9							
2646.76		302.9	272.7	237.4	222.5							
H 2767.06		302.9	272.7	237.4	222.5							
2855.65		302.9	272.7	234.9	208.2							
3609.22		302.9	272.7	237.4	222.5							
4485.75		302.9	272.7	237.4	222.5							
5064.55		302.9	272.7	237.4	222.5							
H 6347.48		302.9	272.7	237.4	222.5							
8522.08		270.8	239.7	204.2	180.6							



	i	Mc [kNm]				n _{1max} [min ⁻¹]	Pt [kW]	Kg				
		n ₂ x h	n ₂ x h	n ₂ x h	n ₂ x h			M	P	CPC	F	FS
		10.000	20.000	50.000	100.000							
PGA 31004	264.13	251.0	203.9	155.0	125.9	2500	56	2498 (2580-H)	-	-	2348 (2430-H)	2456 (2538-H)
	339.05	298.9	242.9	184.6	150.0							
	429.11	302.9	272.7	217.7	176.8							
	515.76	293.6	259.9	221.2	195.7							
	H 605.29	302.9	248.0	188.3	152.9							
	651.99	302.9	261.2	198.3	161.0							
	783.64	293.6	259.9	221.2	183.1							
PGA 31005	H 931.09	344.1	307.7	239.5	194.4	2800	48	2518 (2630-H)	-	-	2368 (2480-H)	2476 (2588-H)
	H 1036.22	346.1	306.4	260.7	230.7							
	H 1195.16	344.1	309.8	269.7	231.6							
	H 1338.25	345.5	305.9	260.4	230.4							
	H 1457.55	326.3	288.8	245.6	217.7							
	H 1574.41	346.1	306.4	260.7	230.7							
	1688.78	294.5	239.3	181.8	147.7							
	1769.68	302.9	247.2	187.9	152.6							
	H 1829.33	302.9	272.7	237.4	222.5							
	1906.68	280.2	248.1	197.9	160.8							
	H 2020.94	302.9	272.7	237.4	222.5							
	2137.41	302.9	272.7	214.4	174.2							
	H 2214.57	326.3	288.8	245.6	217.7							
	2413.20	302.9	272.7	233.4	189.6							
	2569.00	293.6	259.9	221.2	195.7							
	2900.48	293.6	259.9	221.2	195.7							
	3364.56	293.6	259.9	221.2	195.7							
	4571.23	293.6	259.9	221.2	192.5							
	5302.63	293.6	259.9	221.2	195.7							
	6399.72	270.8	239.7	204.2	180.6							

(n₂ x h = 20.000)

M_{max} = M_c x 1.8

31000/31000H

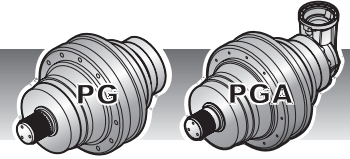

F

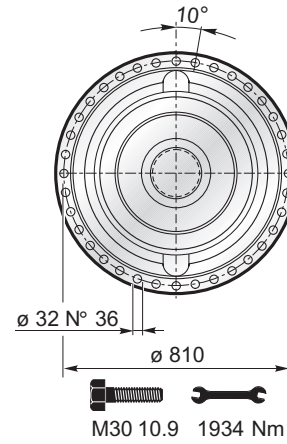
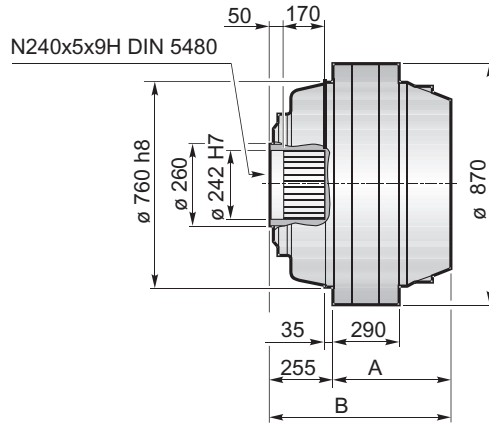

F	A	B
PG31000	485	740
PG31000H	497.5	752.5

FS

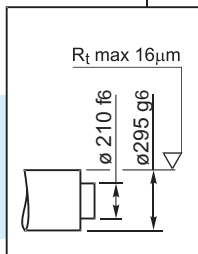
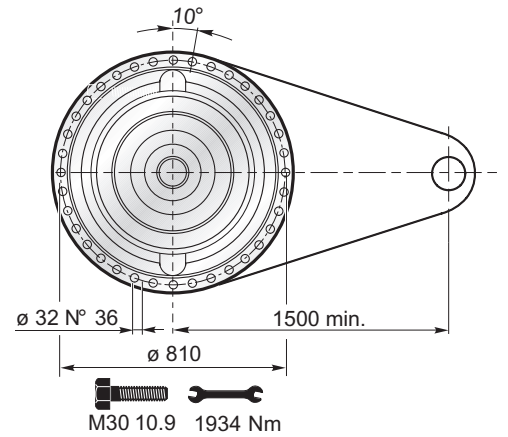
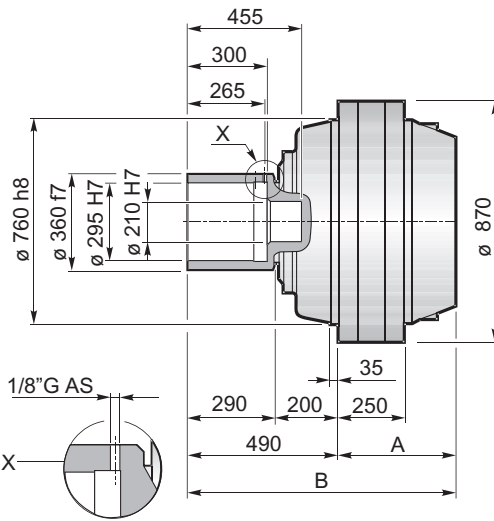

$M_{max} = 753 \text{ kNm}$

La coppia massima indicata è valida solo con calettatori forniti da Planetary Drives
 The maximum torque indicated is valid only with shrink discs supplied by Planetary Drives
 Das dargestellte, maximale Drehmoment gilt nur mit von Planetary Drives gelieferter Schrumpfscheibe
 Le couple maximal indiqué n'est valable qu'avec les frettes de serrage fournis par Planetary Drives
 El momento máximo indicado sólo es válido con discos de contracción suministrados por Planetary Drives
 O torque máximo indicado é válido exclusivamente com discos de contração fornecidos pela Planetary Drives

FS	A	B
PG31000	485	975
PG31000H	497.5	987.5





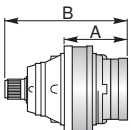

31000/31000H

IT EN DE FR ES PT

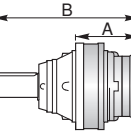
	PG ...MS						Vers. H					
	A	B	RA	RB	EF	EDF	A	B	RA	RB	EF	EDF
PG31001	485	970					497.5	982.5				
PG31002	740	1225					766	1251				
PG31003	922	1407					943	1428				
PG31004	1016	1501		•			1050	1535		•		
PG31005	1075.5	1560.5	•	o	•		1121.5	1606.5	•	o	•	

	PG ...MC						Vers. H					
	A	B	RA	RB	EF	EDF	A	B	RA	RB	EF	EDF
PG31001	485	1135					497.5	1147.5				
PG31002	740	1390					766	1416				
PG31003	922	1572					943	1593				
PG31004	1016	1666		•			1050	1700		•		
PG31005	1075.5	1725.5	•	o	•		1121.5	1771.5	•	o	•	

	PG ...F						Vers. H					
	A	B	RA	RB	EF	EDF	A	B	RA	RB	EF	EDF
PG31001	485	740					497.5	752.5				
PG31002	740	995					766	1021				
PG31003	922	1177					943	1198				
PG31004	1016	1271		•			1050	1305		•		
PG31005	1075.5	1330.5	•	o	•		1121.5	1376.5	•	o	•	

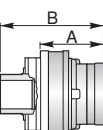
	PG ...FS						Vers. H					
	A	B	RA	RB	EF	EDF	A	B	RA	RB	EF	EDF
PG31001	485	975					497.5	987.5				
PG31002	740	1230					766	1256				
PG31003	922	1412					943	1433				
PG31004	1016	1506		•			1050	1540		•		
PG31005	1075.5	1565.5	•	o	•		1121.5	1611.5	•	o	•	



A	B	•
A+13.5	B+13.5	o

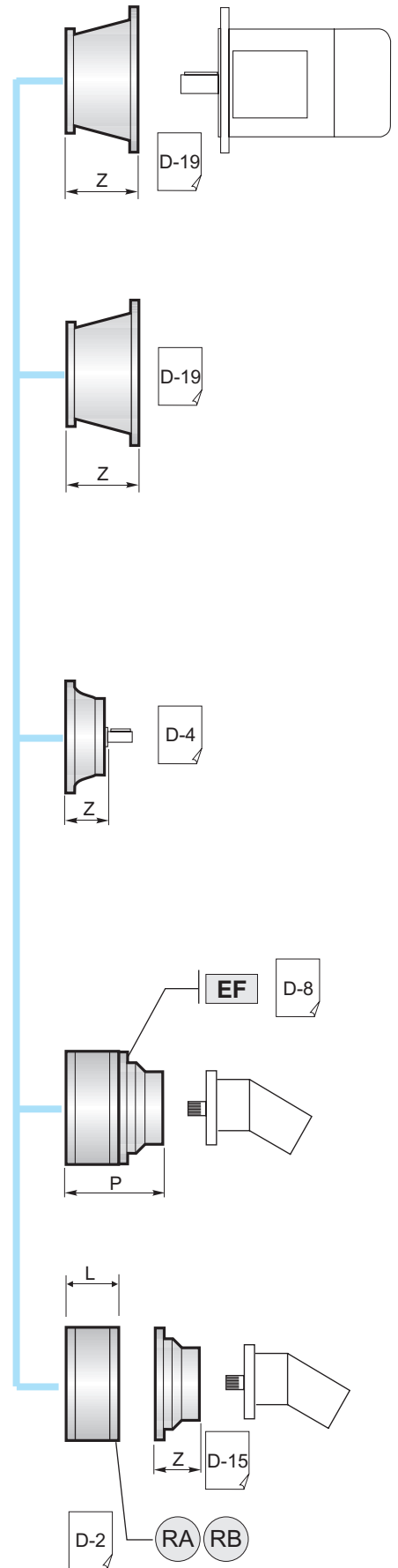

	L
RA	81
RB	125

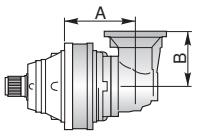

	PGA...MS						Vers. H					
	A	B	RA	RB	EF	EDF	A	B	RA	RB	EF	EDF
PGA31004	1002	315		•			1028	315		•		
PGA31005	1104	240	•	o	•		1138	240	•	o	•	

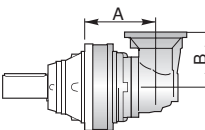
	PGA ...MC						Vers. H					
	A	B	RA	RB	EF	EDF	A	B	RA	RB	EF	EDF
PGA31004	1002	315	•	o	•		1028	315		•		
PGA31005	1104	240	•			•	1138	240	•	o	•	

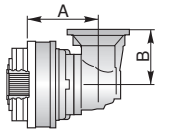
	PGA ...F						Vers. H					
	A	B	RA	RB	EF	EDF	A	B	RA	RB	EF	EDF
PGA31004	1002	315	•	o	•		1028	315		•		
PGA31005	1104	240	•			•	1138	240	•	o	•	

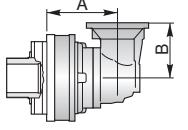
	PGA...FS						Vers. H					
	A	B	RA	RB	EF	EDF	A	B	RA	RB	EF	EDF
PGA31004	1002	315	•	o	•		1028	315		•		
PGA31005	1104	240	•			•	1138	240	•	o	•	



B	•
B+16.5	o

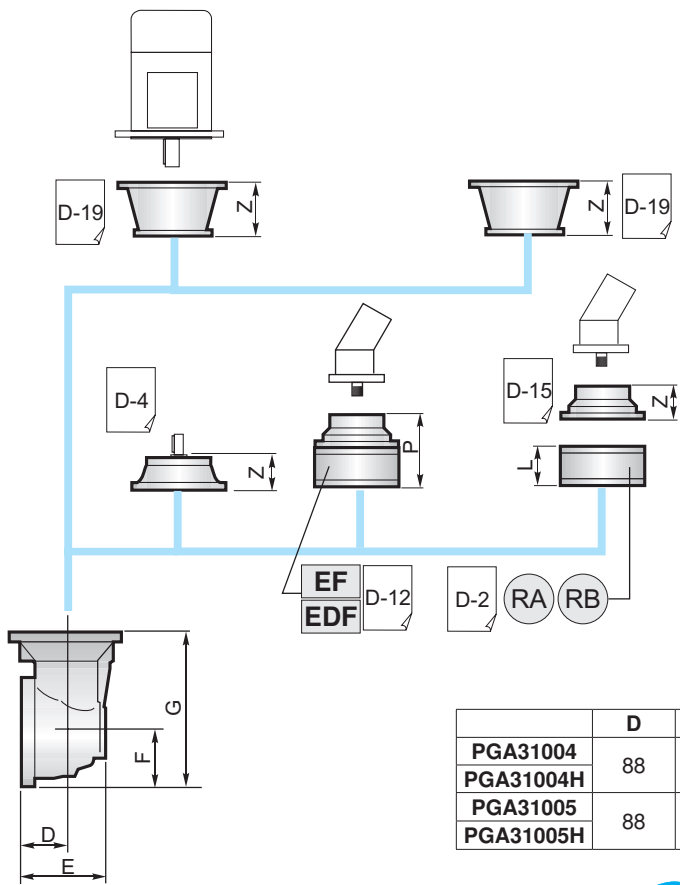

	L
RA	81
RB	125

	D	E	F	G
PGA31004	88	256	235	550
PGA31004H	88	256	235	550
PGA31005	88	256	235	550
PGA31005H	88	256	235	550

31000

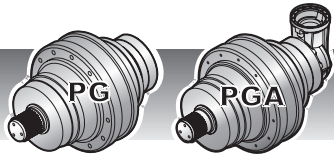

31000/31000H

IT EN DE FR ES PT

GA Giunto di attrito / Shrink disc
Schrumpfscheibe / Frette de serrage
Disco de contracción / Disco de contração

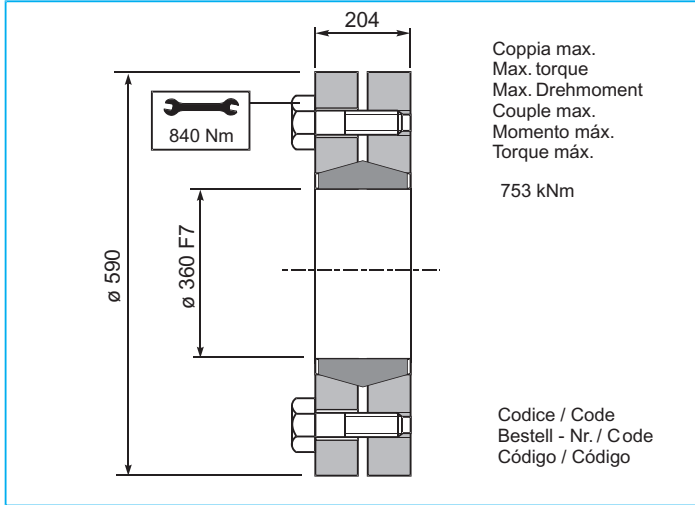

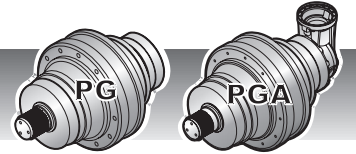

CARICHI RADIALI (Fr)

Nei diagrammi seguenti sono riportati i carichi radiali e i coefficienti K per rapportarli al valore $n_2 \times h$ desiderato.

RADIAL LOADS (Fr)

The following curves show the radial loads and the K factors to obtain the required $n_2 \times h$ value.

RADIALLAST (Fr)

In den nachstehenden Diagrammen ist die Radiallast und der Koeffizient K dargestellt und kann mit dem gewünschten Wert $n_2 \times h$ verglichen werden.

CHARGES RADIALES (Fr)

Dans les diagrammes suivants sont indiqués les charges radiales et les facteurs K de façon à obtenir la valeur $n_2 \times h$ désirée.

CARGAS RADIALES (Fr)

En los siguientes diagramas se indican las cargas radiales y los coeficientes K para obtener el valor requerido $n_2 \times h$.

CARGAS RADIAIS (Fr)

Nos diagramas seguintes são indicadas as cargas radiais e os coeficientes K para obter o valor $n_2 \times h$ desejado.

M

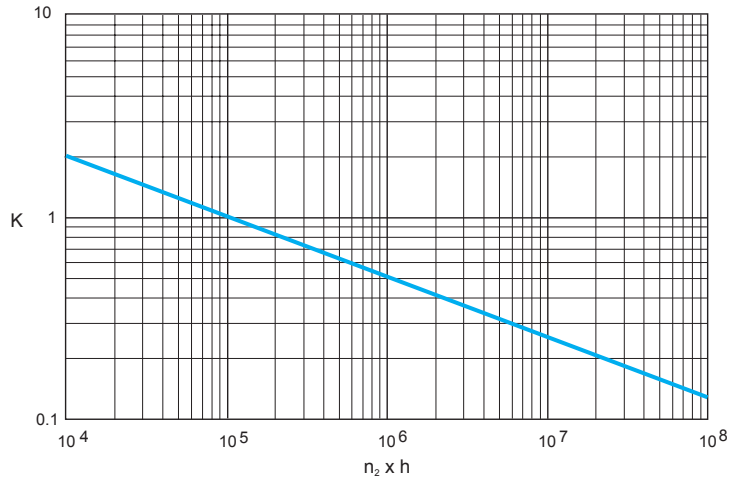
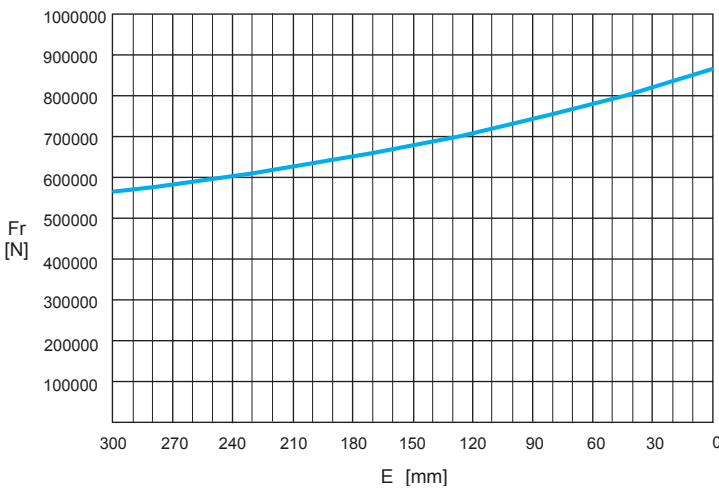

	$n_2 \times h$				
	10^5	10^4	10^6	10^7	10^8
M	Fr		Fr • K		

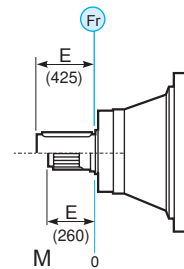

CARICHI ASSIALI (Fa)

I valori dei carichi assiali indicati in tabella sono riferiti alle versioni e alla direzione di applicazione del carico.

AXIAL LOADS (Fa)

The values of the axial loads in the table refer to the output versions and load direction of application.

AXIALLAST (Fa)

Die dargestellten Werte der Axiallast basieren auf der Version und der applizierten Lastrichtung.

CHARGES AXIALES (Fa)

Les valeurs des charges axiales indiquées dans le tableau se réfèrent aux versions et à la direction d'application de la charge.

CARGAS AXIALES (Fa)

Los valores de las cargas axiales indicados en la tabla se refieren a las versiones y a la dirección de aplicación de la carga.

CARGAS AXIAIS (Fa)

Os valores das cargas axiais indicadas na tabela referem-se às versões e à direção de aplicação da carga.

Fa	M	
	[N]	240000
	160500	→

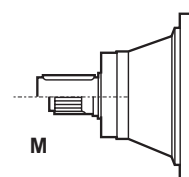



40000

IT EN DE FR ES PT

	i	Mc [kNm]				n _{1max} [min ⁻¹]	Pt [kW]	Kg												
		n ₂ x h	n ₂ x h	n ₂ x h	n ₂ x h			M	P	CPC	F	FS								
		10.000	20.000	50.000	100.000															
PG 40001	3.43	426.9	384.4	334.7	301.4	200	224	2030	-	-	1880	1988								
	4.09	502.7	452.7	394.1	336.8															
	5.25	376.4	338.9	295.0	276.5															
PG 40002	14.03	426.9	384.4	334.7	301.4	750	130	2400	-	-	2250	2358								
	16.73	502.7	452.7	394.1	336.8															
	18.01	372.5	335.4	292.0	273.7															
	21.47	432.8	389.7	339.3	318.0															
	27.56	376.4	338.9	295.0	276.5															
	32.71	376.4	338.9	295.0	276.5															
PG 40003	56.11	351.3	310.9	264.6	234.2	1500	75	2512	-	-	2362	2470								
	66.91	406.1	359.5	305.9	270.8															
	72.03	372.5	335.4	292.0	273.7															
	85.89	376.4	338.9	295.0	276.5															
	110.25	376.4	338.9	295.0	276.5															
	129.71	376.4	338.9	295.0	276.5															
	153.92	291.2	262.2	228.3	218.2															
	182.65	291.2	262.2	228.3	218.2															
PG 40004	237.91	402.0	355.7	302.7	268.0	2800	68	2547	-	-	2397	2505								
	256.11	372.5	335.4	292.0	273.7															
	305.39	376.4	338.9	295.0	276.5															
	392.00	376.4	338.9	295.0	276.5															
	433.06	376.4	338.9	295.0	276.5															
	472.50	376.4	338.9	295.0	276.5															
	555.88	376.4	338.9	295.0	276.5															
	617.40	376.4	338.9	295.0	270.3															
	726.35	376.4	338.9	295.0	276.5															
	744.19	309.5	273.9	233.0	206.2															
	875.51	353.8	313.1	266.4	235.7															
	1038.94	291.2	262.2	228.3	218.2															
	PG 40005	1153.68	376.4	338.9	295.0								276.5	2800	55	2562	-	-	2412	2520
		1259.72	376.4	338.9	295.0								276.5							
1390.60		376.4	338.9	295.0	276.5															
1518.41		376.4	338.9	295.0	276.5															
1577.83		376.4	338.9	295.0	276.5															
1679.37		346.1	306.4	260.7	230.7															
1742.22		376.4	338.9	295.0	276.5															
1832.32		373.0	330.4	281.0	249.3															
1949.06		376.4	338.9	295.0	276.5															
2025.33		376.4	338.9	295.0	276.5															
2100.00		376.4	338.9	295.0	276.5															
2293.01		376.4	338.9	295.0	276.5															
2382.75		376.4	338.9	295.0	276.5															
2546.78		376.4	338.9	295.0	270.3															
2668.73		340.4	301.2	256.2	227.3															
2767.06		376.4	338.9	295.0	276.5															
2872.06		376.4	338.9	295.0	276.5															
3611.50		353.8	313.1	266.4	235.7															
4476.15		376.4	338.9	295.0	270.3															
5253.09		353.8	313.1	266.4	235.7															
6347.48		353.8	313.1	266.4	235.7															
8938.38	291.2	262.2	228.3	218.2																



	i	Mc [kNm]				n _{1max} [min ⁻¹]	Pt [kW]	Kg				
		n ₂ x h	n ₂ x h	n ₂ x h	n ₂ x h			M	P	CPC	F	FS
		10.000	20.000	50.000	100.000							
PGA 40005	925.43	367.8	325.5	277.0	245.2	2500	52	2663	-	-	2513	2621
	1103.50	376.4	338.9	295.0	276.5							
	1204.00	376.4	338.9	295.0	276.5							
	1330.11	376.4	338.9	295.0	276.5							
	1451.25	376.4	338.9	295.0	276.5							
	1574.41	346.1	306.4	260.7	230.7							
	1676.63	376.4	338.9	295.0	276.5							
	1738.01	376.4	333.8	283.9	251.6							
	1829.33	376.4	338.9	295.0	276.5							
	1896.30	376.4	338.9	295.0	270.3							
	2020.94	376.4	338.9	295.0	276.5							
	2152.16	376.4	338.9	295.0	276.5							
	2230.94	376.4	338.9	295.0	276.5							
	2485.97	291.2	262.2	228.3	218.2							
	2594.12	376.4	338.9	295.0	276.5							
	2881.20	376.4	338.9	295.0	270.3							
	3389.65	376.4	338.9	295.0	276.5							
	4085.74	353.8	313.1	266.4	235.7							
	5753.44	291.2	262.2	228.3	218.2							
	6279.06	290.2	257.0	218.6	193.5							

(n₂ x h = 20.000)
 $M_{max} = M_c \times 1.5$

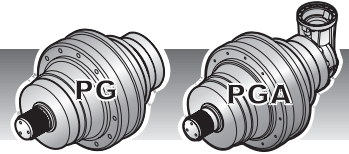

F

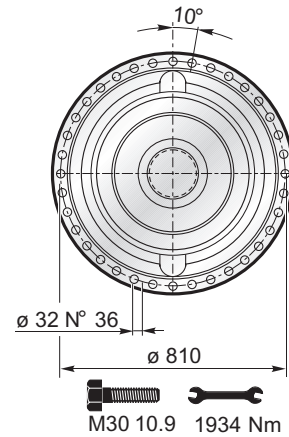
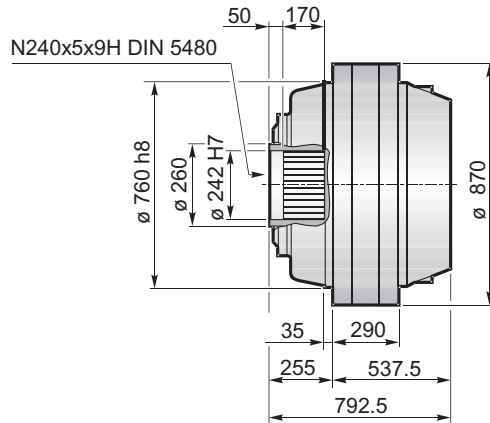

FS

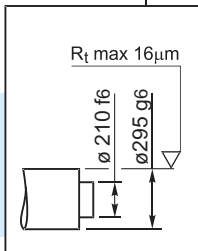
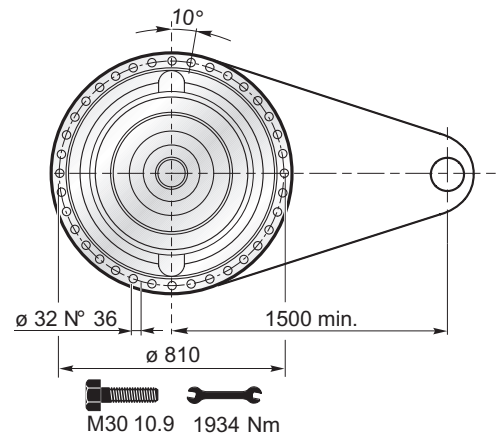
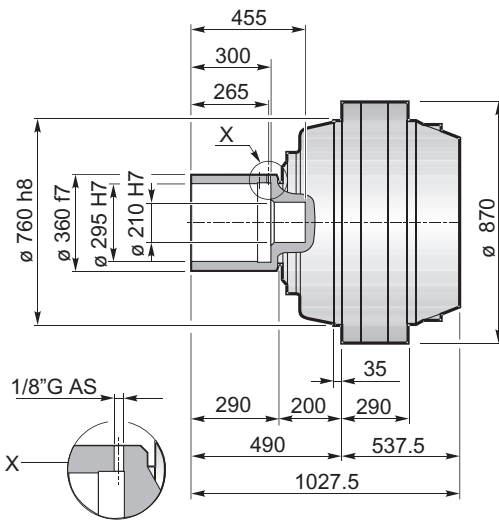

$M_{max} = 753 \text{ kNm}$

La coppia massima indicata è valida solo con calettatori forniti da Planetary Drives
 The maximum torque indicated is valid only with shrink discs supplied by Planetary Drives
 Das dargestellte, maximale Drehmoment gilt nur mit von Planetary Drives gelieferter Schrumpfscheibe
 Le couple maximal indiqué n'est valable qu'avec les frettes de serrage fournis par Planetary Drives
 El momento máximo indicado sólo es válido con discos de contracción suministrados por Planetary Drives
 O torque máximo indicado é válido exclusivamente com discos de contração fornecidos pela Planetary Drives



40000

IT EN DE FR ES PT

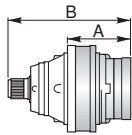
	PG ...MS					
	A	B	RA	RB	EF	EDF
PG40001	537.5	1022.5				
PG40002	806	1291				
PG40003	1003	1488				
PG40004	1090	1575		•		
PG40005	1161.5	1646.5	•	o	•	

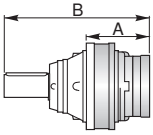
	PG ...MS					
	A	B	RA	RB	EF	EDF
PG40001	537.5	1187.5				
PG40002	806	1456				
PG40003	1003	1653				
PG40004	1090	1740		•		
PG40005	1161.5	1811.5	•	o	•	

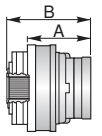
	PG ...MS					
	A	B	RA	RB	EF	EDF
PG40001	537.5	792.5				
PG40002	806	1061				
PG40003	1003	1258				
PG40004	1090	1345		•		
PG40005	1161.5	1416.5	•	o	•	

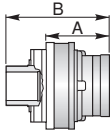
	PG ...MS					
	A	B	RA	RB	EF	EDF
PG40001	537.5	1027.5				
PG40002	806	1296				
PG40003	1003	1493				
PG40004	1090	1580		•		
PG40005	1161.5	1651.5	•	o	•	



A	B	•
A+13.5	B+13.5	o

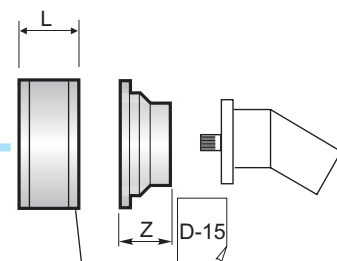
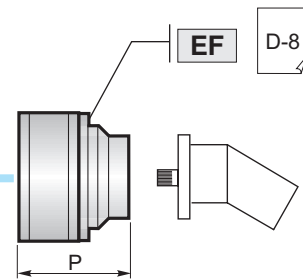
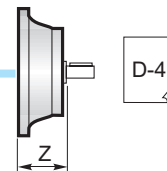
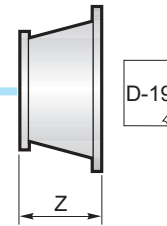
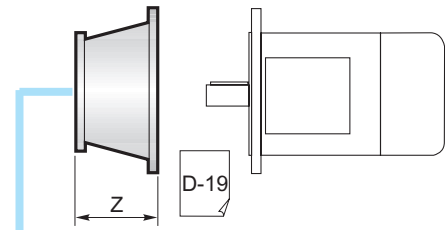

	L
RA	81
RB	125



		PGA ...MS					
		A	B	RA	RB	EF	EDF
PGA40005		1178	240	•	o	•	

		PGA ...MC					
		A	B	RA	RB	EF	EDF
PGA40005		1178	240	•	o	•	

		PGA ...F					
		A	B	RA	RB	EF	EDF
PGA40005		1178	240	•	o	•	

		PGA ...FS					
		A	B	RA	RB	EF	EDF
PGA40005		1178	240	•	o	•	



B	•
B+16.5	o

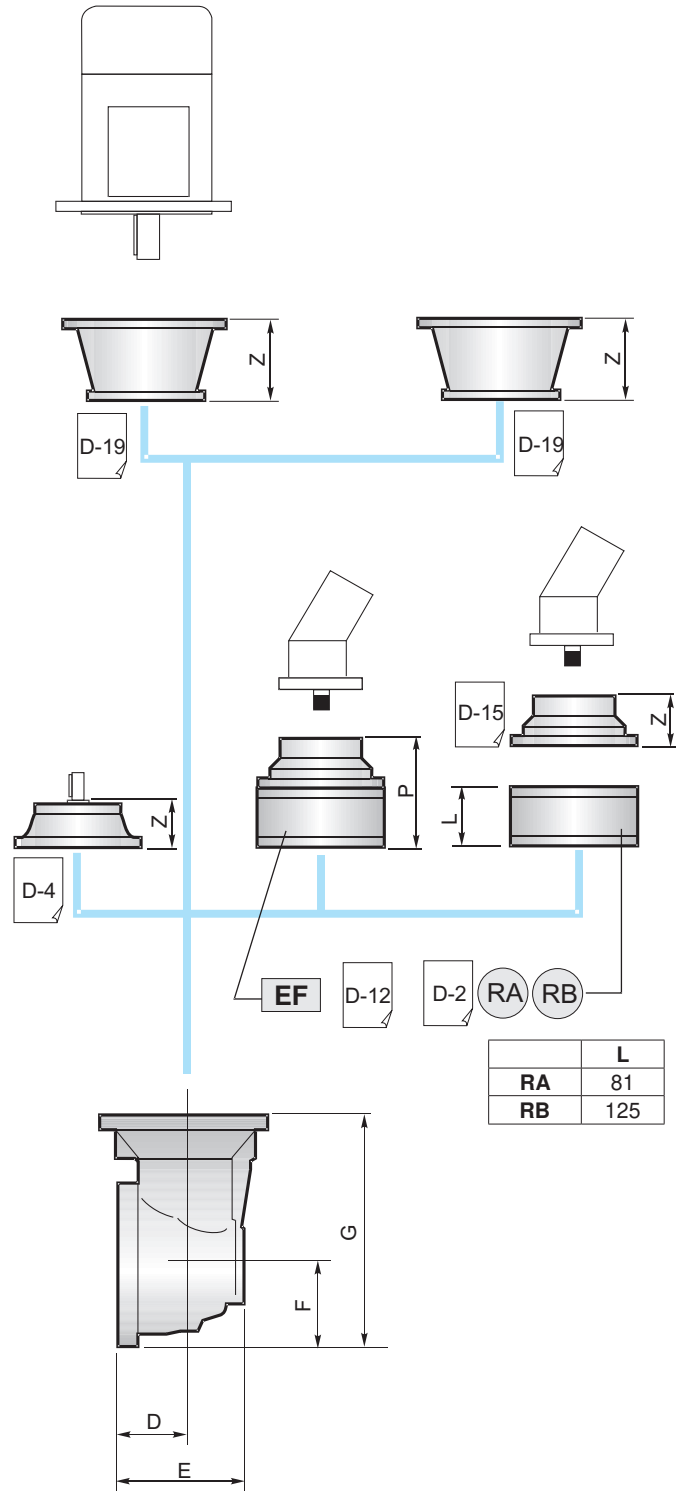

	D	E	F	G
PGA40005	88	256	235	550

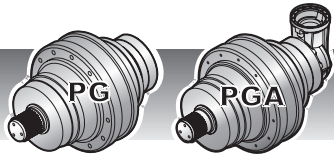

40000

IT EN DE FR ES PT

GA Giunto di attrito / Shrink disc
Schrumpfscheibe / Frette de serrage
Disco de contracción / Disco de contração

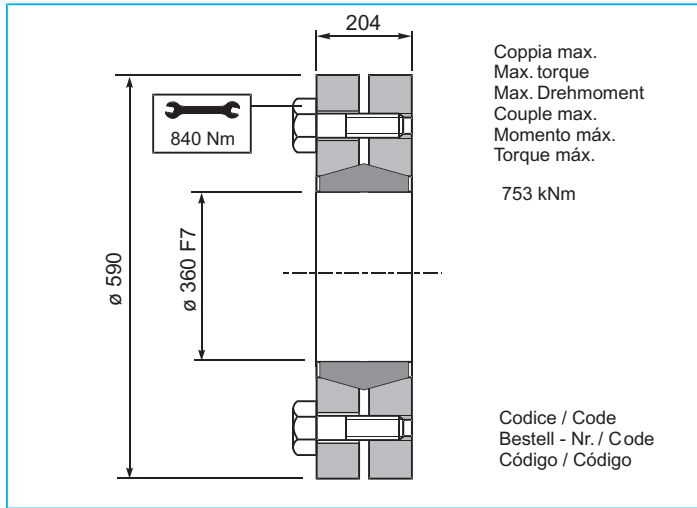



CARICHI RADIALI (Fr)

Nei diagrammi seguenti sono riportati i carichi radiali e i coefficienti K per rapportarli al valore $n_2 \times h$ desiderato.

RADIAL LOADS (Fr)

The following curves show the radial loads and the K factors to obtain the required $n_2 \times h$ value.

RADIALLAST (Fr)

In den nachstehenden Diagrammen ist die Radiallast und der Koeffizient K dargestellt und kann mit dem gewünschten Wert $n_2 \times h$ verglichen werden.

CHARGES RADIALES (Fr)

Dans les diagrammes suivants sont indiqués les charges radiales et les facteurs K de façon à obtenir la valeur $n_2 \times h$ désirée.

CARGAS RADIALES (Fr)

En los siguientes diagramas se indican las cargas radiales y los coeficientes K para obtener el valor requerido $n_2 \times h$.

CARGAS RADIAIS (Fr)

Nos diagramas seguintes são indicadas as cargas radiais e os coeficientes K para obter o valor $n_2 \times h$ desejado.

M

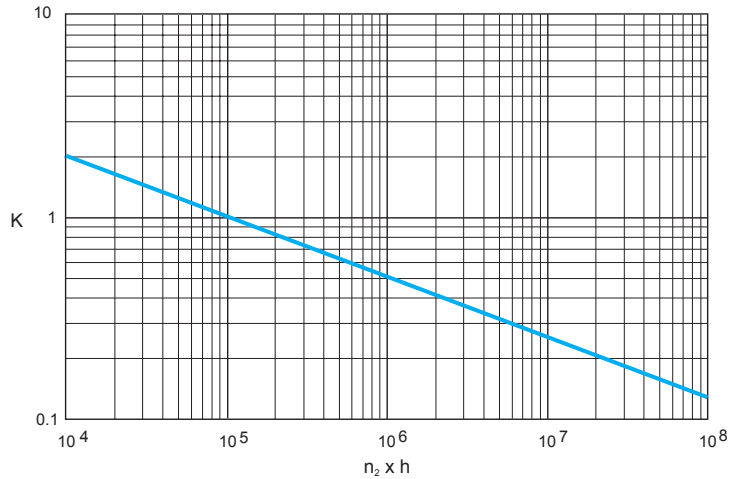
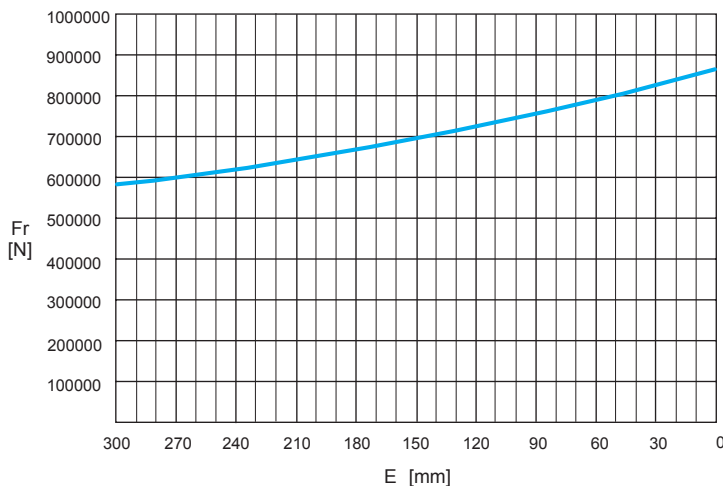

	$n_2 \times h$				
	10^5	10^4	10^6	10^7	10^8
M	Fr		Fr • K		

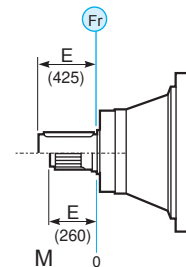

CARICHI ASSIALI (Fa)

I valori dei carichi assiali indicati in tabella sono riferiti alle versioni e alla direzione di applicazione del carico.

AXIAL LOADS (Fa)

The values of the axial loads in the table refer to the output versions and load direction of application.

AXIALLAST (Fa)

Die dargestellten Werte der Axiallast basieren auf der Version und der applizierten Lastrichtung.

CHARGES AXIALES (Fa)

Les valeurs des charges axiales indiquées dans le tableau se réfèrent aux versions et à la direction d'application de la charge.

CARGAS AXIALES (Fa)

Los valores de las cargas axiales indicados en la tabla se refieren a las versiones y a la dirección de aplicación de la carga.

CARGAS AXIAIS (Fa)

Os valores das cargas axiais indicadas na tabela referem-se às versões e à direção de aplicação da carga.

Fa	M	
	[N]	240000
	160500	→

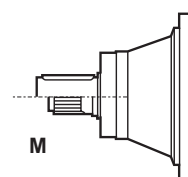

40000



45000

IT EN DE FR ES PT

	i	Mc [kNm]				n _{1max} [min ⁻¹]	Pt [kW]	Kg				
		n ₂ x h	n ₂ x h	n ₂ x h	n ₂ x h			M	P	CPC	F	FS
		10.000	20.000	50.000	100.000							
PG 45001	3.83	630.2	567.4	493.9	452.0	200	224	2030	-	-	1880	1918
PG 45002	14.69	630.2	567.4	493.9	452.0	750	133	2435	-	-	2285	2323
	16.87	629.4	566.8	493.4	452.0							
PG 45003	58.11	591.8	523.8	445.7	394.6	1500	90	2551	-	-	2401	2439
	66.70	629.4	566.8	493.4	442.0							
	74.39	433.2	383.4	326.2	288.8							
	85.39	485.3	429.5	365.5	323.5							
	101.20	387.1	342.6	291.6	258.1							
PG 45004	237.16	591.3	523.3	445.2	394.1	2800	73	2578	-	-	2428	2466
	285.86	515.2	456.0	388.0	343.6							
	318.82	433.2	383.4	326.2	288.8							
	365.95	485.3	429.5	365.5	323.5							
	416.59	431.2	381.6	324.7	287.6							
	478.17	483.0	427.5	363.8	322.1							
	566.72	387.1	342.6	291.6	258.1							
	683.10	387.1	342.6	291.6	258.1							
PG 45005	780.54	413.6	366.3	311.8	276.0	2800	59	2592	-	-	2442	2480
	895.92	463.4	410.4	349.4	309.2							
	940.83	459.9	407.0	346.3	306.7							
	1079.90	515.2	456.0	388.0	343.6							
	1252.35	485.3	429.5	365.5	323.5							
	1382.46	485.3	429.5	365.5	323.5							
	1509.53	485.3	429.5	365.5	323.5							
	1647.22	433.2	383.4	326.2	288.8							
	1890.72	485.3	429.5	365.5	323.5							
	1972.45	483.0	427.5	363.8	322.1							
	2152.37	431.2	381.6	324.7	287.6							
	2470.55	483.0	427.5	363.8	322.1							
	2602.29	387.1	342.6	291.6	258.1							
	2869.02	483.0	427.5	363.8	322.1							
	3144.43	387.1	342.6	291.6	258.1							
	3466.73	422.3	373.7	317.8	282.0							
	4098.60	387.1	342.6	291.6	258.1							
	4314.66	345.5	305.8	260.3	230.4							
4952.48	387.1	342.6	291.6	258.1								



	i	Mc [kNm]				n _{1max} [min ⁻¹]	Pt [kW]	Kg				
		n ₂ x h	n ₂ x h	n ₂ x h	n ₂ x h			M	P	CPC	F	FS
		10.000	20.000	50.000	100.000							
PGA 45005	634.60	436.2	354.4	269.3	218.8	2500	52	2698	-	-	2548	2586
	728.41	480.4	390.3	296.6	241.0							
	764.92	459.9	403.9	306.9	249.4							
	877.99	515.2	444.8	338.0	274.6							
	932.49	485.3	429.5	352.6	286.5							
	1123.98	485.3	429.5	365.5	323.5							
	1234.33	433.2	383.4	291.7	236.8							
	1334.00	499.7	405.7	308.0	250.1							
	1468.67	483.0	427.5	363.8	322.1							
	1707.75	485.3	429.5	365.5	297.3							
	1944.08	431.2	381.6	324.7	287.6							
	2231.46	483.0	427.5	363.8	322.1							
	2644.69	387.1	342.6	291.6	258.1							
	3187.80	387.1	342.6	291.6	258.1							

(n₂ x h = 20.000)
 $M_{max} = M_C \times 1.2$

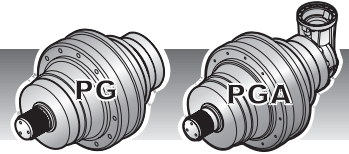

F

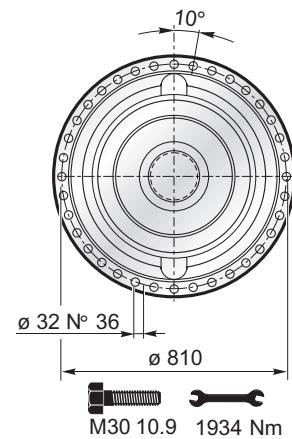
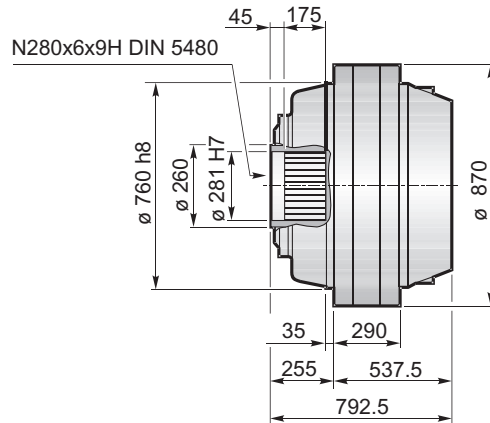

FS

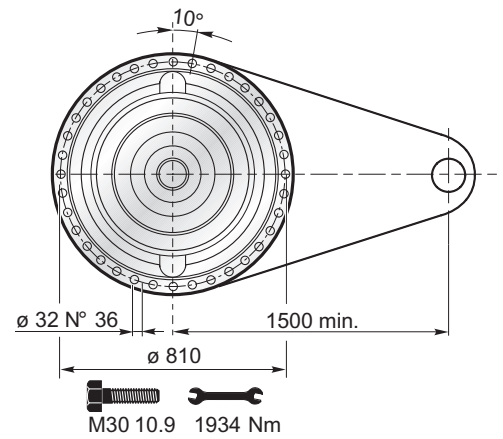
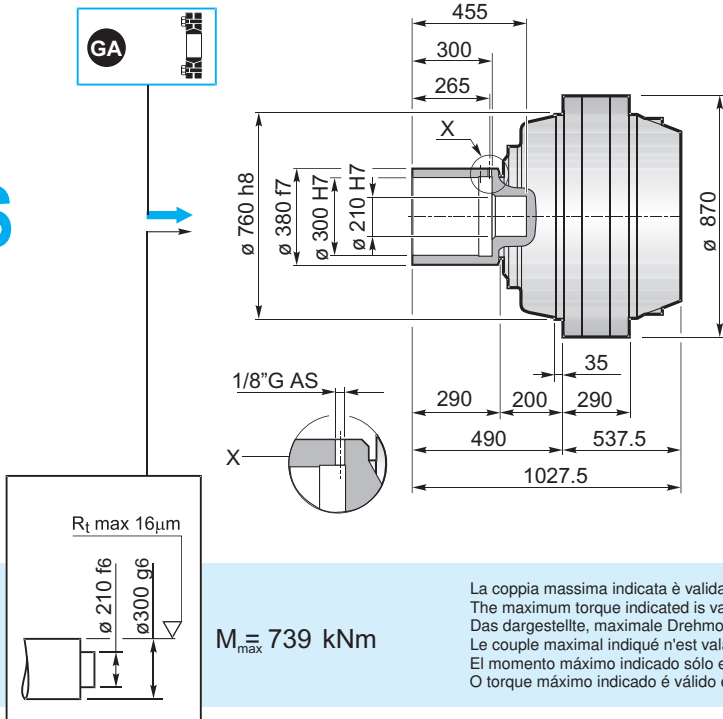

$M_{max} = 739 \text{ kNm}$

La coppia massima indicata è valida solo con calettatori forniti da Planetary Drives
 The maximum torque indicated is valid only with shrink discs supplied by Planetary Drives
 Das dargestellte, maximale Drehmoment gilt nur mit von Planetary Drives gelieferter Schrumpfscheibe
 Le couple maximal indiqué n'est valable qu'avec les frettes de serrage fournis par Planetary Drives
 El momento máximo indicado sólo es válido con discos de contracción suministrados por Planetary Drives
 O torque máximo indicado é válido exclusivamente com discos de contração fornecidos pela Planetary Drives



45000

IT EN DE FR ES PT

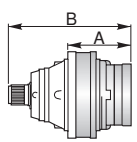

PG		...MS				
	A	B	RA	RB	EF	EDF
PG45001	537.5	1022.5				
PG45002	884.5	1369.5				
PG45003	1105.5	1590.5				
PG45004	1212.5	1697.5		•		
PG45005	1284	1769	•	o	•	

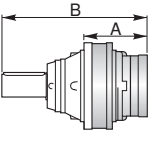

PG		...MS				
	A	B	RA	RB	EF	EDF
PG45001	537.5	1187.5				
PG45002	884.5	1534.5				
PG45003	1105.5	1755.5				
PG45004	1212.5	1862.5		•		
PG45005	1284	1934	•	o	•	

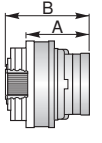

PG		...MS				
	A	B	RA	RB	EF	EDF
PG45001	537.5	797.5				
PG45002	884.5	1144.5				
PG45003	1105.5	1365.5				
PG45004	1212.5	1472.5		•		
PG45005	1284	1544	•	o	•	

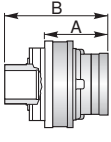

PG		...MS				
	A	B	RA	RB	EF	EDF
PG45001	537.5	1027.5				
PG45002	884.5	1374.5				
PG45003	1105.5	1595.5				
PG45004	1212.5	1702.5		•		
PG45005	1284	1774	•	o	•	



A	B	•
A+13.5	B+13.5	o

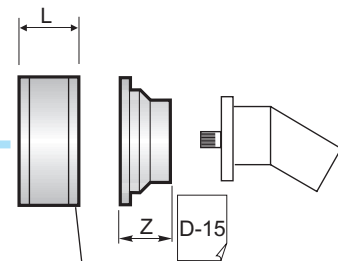
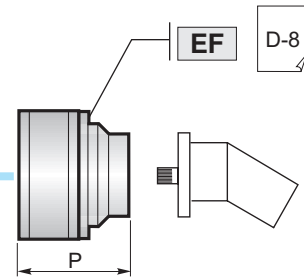
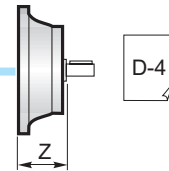
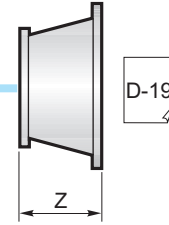
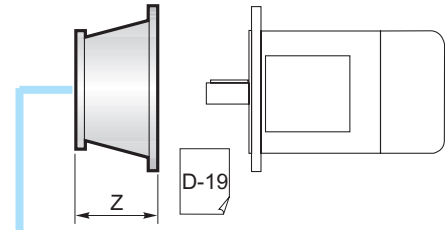

	L
RA	81
RB	125



		PGA ...MS					
		A	B	RA	RB	EF	EDF
PGA45005		1300.5	240	•	o	•	

		PGA ...MC					
		A	B	RA	RB	EF	EDF
PGA45005		1178	240	•	o	•	

		PGA ...F					
		A	B	RA	RB	EF	EDF
PGA45005		1178	240	•	o	•	

		PGA ...FS					
		A	B	RA	RB	EF	EDF
PGA45005		1178	240	•	o	•	



B	•
B+16.5	o

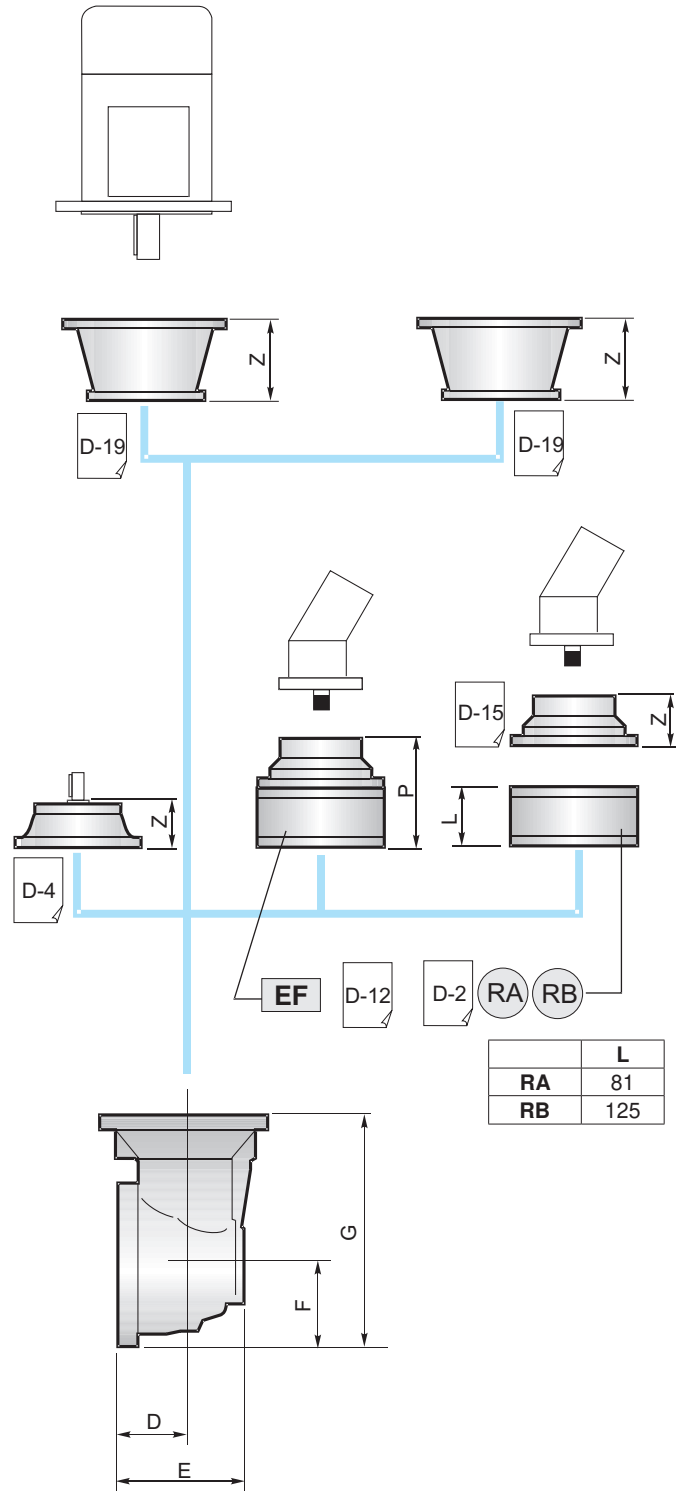

	D	E	F	G
PGA45005	88	256	235	550

45000

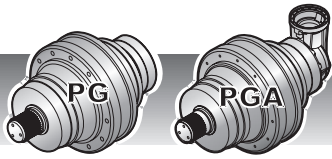

45000

IT EN DE FR ES PT

GA Giunto di attrito / Shrink disc
Schrumpfscheibe / Frette de serrage
Disco de contracción / Disco de contração

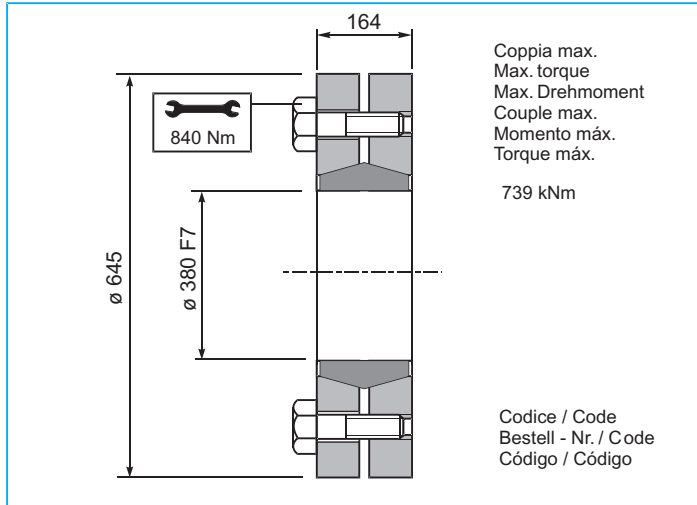

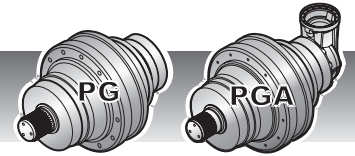

CARICHI RADIALI (Fr)

Nei diagrammi seguenti sono riportati i carichi radiali e i coefficienti K per rapportarli al valore $n_2 \times h$ desiderato.

RADIAL LOADS (Fr)

The following curves show the radial loads and the K factors to obtain the required $n_2 \times h$ value.

RADIALLAST (Fr)

In den nachstehenden Diagrammen ist die Radiallast und der Koeffizient K dargestellt und kann mit dem gewünschten Wert $n_2 \times h$ verglichen werden.

CHARGES RADIALES (Fr)

Dans les diagrammes suivants sont indiqués les charges radiales et les facteurs K de façon à obtenir la valeur $n_2 \times h$ désirée.

CARGAS RADIALES (Fr)

En los siguientes diagramas se indican las cargas radiales y los coeficientes K para obtener el valor requerido $n_2 \times h$.

CARGAS RADIAIS (Fr)

Nos diagramas seguintes são indicadas as cargas radiais e os coeficientes K para obter o valor $n_2 \times h$ desejado.

M

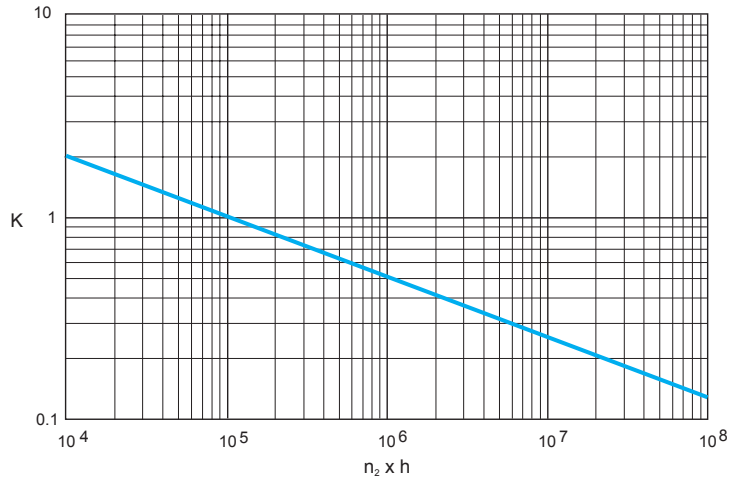
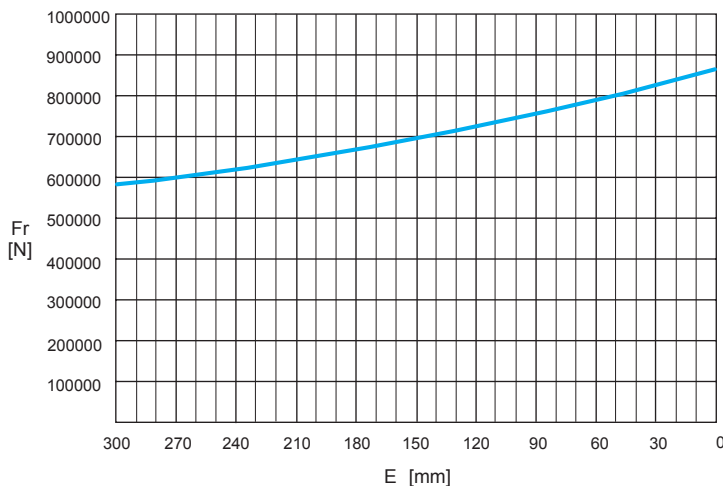

	$n_2 \times h$				
	10^5	10^4	10^6	10^7	10^8
M	Fr				Fr • K

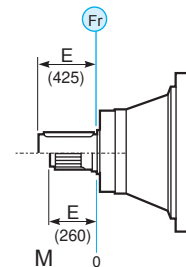

CARICHI ASSIALI (Fa)

I valori dei carichi assiali indicati in tabella sono riferiti alle versioni e alla direzione di applicazione del carico.

AXIAL LOADS (Fa)

The values of the axial loads in the table refer to the output versions and load direction of application.

AXIALLAST (Fa)

Die dargestellten Werte der Axiallast basieren auf der Version und der applizierten Lastrichtung.

CHARGES AXIALES (Fa)

Les valeurs des charges axiales indiquées dans le tableau se réfèrent aux versions et à la direction d'application de la charge.

CARGAS AXIALES (Fa)

Los valores de las cargas axiales indicados en la tabla se refieren a las versiones y a la dirección de aplicación de la carga.

CARGAS AXIAIS (Fa)

Os valores das cargas axiais indicadas na tabela referem-se às versões e à direção de aplicação da carga.

Fa	M	
	[N]	240000
	160500	→

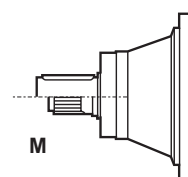



53000

IT EN DE FR ES PT

	i	Mc [kNm]				n _{1max} [min ⁻¹]	Pt [kW]	Kg				
		n ₂ x h	n ₂ x h	n ₂ x h	n ₂ x h			M	P	CPC	F	FS
		10.000	20.000	50.000	100.000							
PG 53001	3.84	807.6	727.2	633.1	571.3	100	324	-	-	-	3200	3257
	5.44	458.3	412.7	359.3	338.1							
PG 53002	14.13	715.0	609.9	463.3	376.3	200	185	-	-	-	3710	3767
	18.97	514.7	463.5	403.5	363.4							
	26.87	458.3	412.7	359.3	338.1							
PG 53003	55.88	573.0	507.2	431.6	376.3	1200	125	-	-	-	3905	3962
	75.02	514.7	463.5	403.5	363.4							
	96.03	514.7	463.5	402.6	356.4							
	106.27	458.3	412.7	359.3	338.1							
	136.05	458.3	412.7	359.3	338.1							
	161.24	458.3	412.7	359.3	338.1							
PG 53004	198.69	511.1	452.4	384.8	340.6	2000	92	-	-	-	3964	4021
	239.50	445.3	394.1	335.4	297.0							
	266.72	514.7	463.5	403.5	363.4							
	321.50	514.7	463.5	403.5	363.4							
	411.57	514.7	463.5	402.6	356.4							
	455.46	458.3	412.7	359.3	338.1							
	537.79	514.7	463.5	400.8	354.9							
	595.13	458.3	412.7	359.3	338.1							
	691.04	458.3	412.7	359.3	338.1							
	761.87	458.3	412.7	359.3	338.1							
	902.95	458.3	412.7	359.3	338.1							
	1088.38	458.3	412.7	359.3	338.1							
	PG 53005	1214.55	514.7	463.5	403.5							
1326.18		514.7	463.5	403.5	362.3							
1408.49		514.7	463.5	402.6	356.4							
1486.43		458.3	412.7	359.3	338.1							
1554.83		514.7	463.5	402.6	356.4							
1640.86		458.3	412.7	359.3	338.1							
1752.98		458.3	411.1	349.6	309.7							
1861.79		458.3	412.7	359.3	325.4							
1952.27		458.3	412.7	359.3	338.1							
2031.64		514.7	463.5	400.8	354.9							
2126.46		514.7	463.5	402.6	356.4							
2218.38		514.7	463.5	400.8	354.9							
2364.88		458.3	412.7	359.3	338.1							
2499.24		458.3	412.7	359.3	338.1							
2660.01		453.9	401.7	341.8	302.7							
2778.57		514.7	463.5	400.8	354.9							
2878.16		458.3	412.7	359.3	338.1							
3226.73		514.7	463.5	400.8	354.9							
4489.57		458.3	412.7	359.3	338.1							
5010.01		458.3	412.7	359.3	338.1							
6546.41	458.3	412.7	359.3	338.1								
7890.76	458.3	412.7	359.3	338.1								



	i	Mc [kNm]				n _{1max} [min ⁻¹]	Pt [kW]	Kg				
		n ₂ x h	n ₂ x h	n ₂ x h	n ₂ x h			M	P	CPC	F	FS
		10.000	20.000	50.000	100.000							
PGA 53005	819.22	514.7	423.8	322.0	261.6	2500	73	-	-	-	4086	4143
	864.55	458.3	412.7	334.4	271.7							
	987.46	514.7	463.5	367.0	298.2							
	1160.57	458.3	412.7	359.3	333.9							
	1244.71	476.1	386.5	293.4	238.2							
	1334.06	458.3	412.7	359.3	338.1							
	1398.90	458.3	412.7	359.3	338.1							
	1500.32	514.7	440.5	334.4	271.5							
	1593.45	514.7	459.5	348.8	283.2							
	1743.17	458.3	412.7	359.3	338.1							
	1827.89	458.3	412.7	359.3	338.1							
	1920.67	514.7	463.5	397.5	322.7							
	2125.46	458.3	412.7	359.3	338.1							
	2340.02	458.3	412.7	359.3	338.1							
	2509.68	514.7	463.5	400.8	354.9							
	2820.56	458.3	412.7	359.3	338.1							
	3224.83	458.3	412.7	359.3	338.1							
	4213.78	458.3	412.7	359.3	338.1							
	5079.11	458.3	412.7	359.3	338.1							

(n₂ x h = 20.000)
 $M_{max} = M_c \times 1.6$

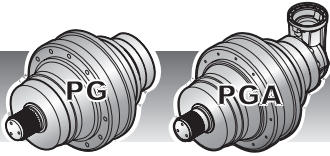

53000

IT EN DE FR ES PT

F

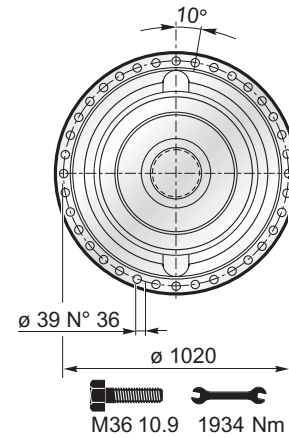
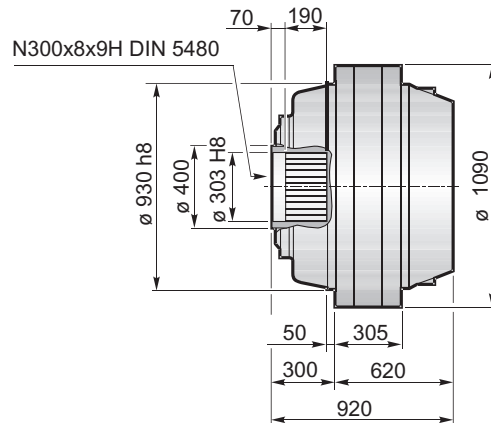

FS

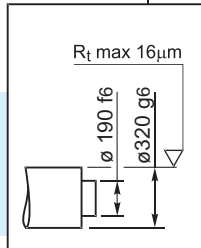
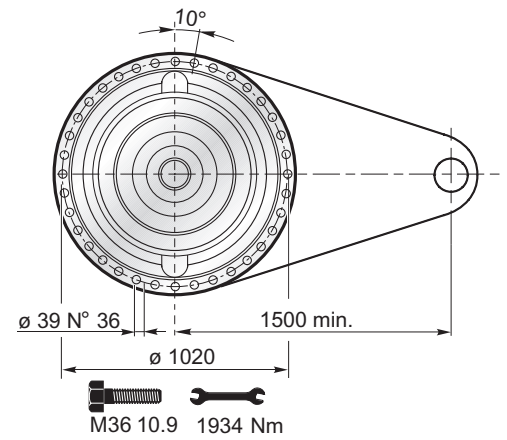
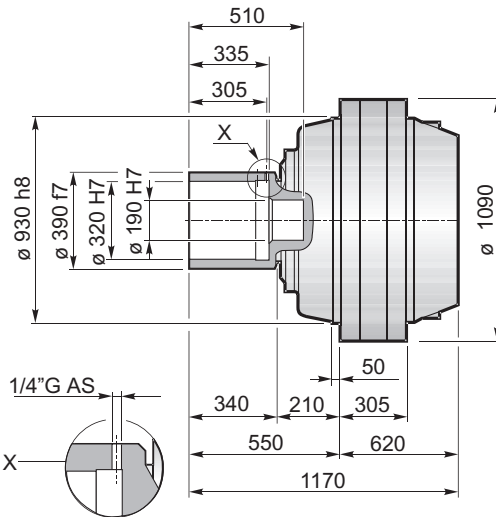

$M_{max} \cong 986 \text{ kNm}$

La coppia massima indicata è valida solo con calettatori forniti da Planetary Drives
 The maximum torque indicated is valid only with shrink discs supplied by Planetary Drives
 Das dargestellte, maximale Drehmoment gilt nur mit von Planetary Drives gelieferter Schrumpfscheibe
 Le couple maximal indiqué n'est valable qu'avec les frettes de serrage fournis par Planetary Drives
 El momento máximo indicado sólo es válido con discos de contracción suministrados por Planetary Drives
 O torque máximo indicado é válido exclusivamente com discos de contração fornecidos pela Planetary Drives

GA Giunto di attrito / Shrink disc
 Schrumpfscheibe / Frette de serrage
 Disco de contração / Disco de contração

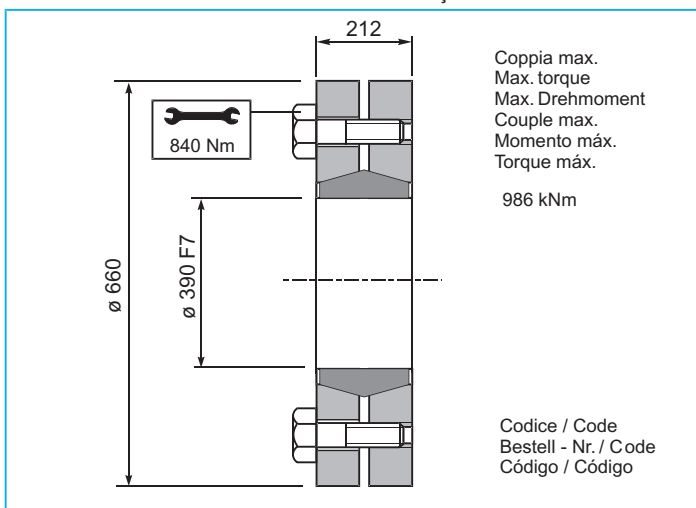

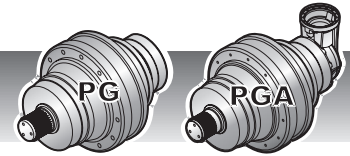

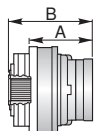
	PG ...F					
	A	B	RA	RB	EF	EDF
PG53001	620	920				
PG53002	903.5	1203.5				
PG53003	1124.5	1424.5				
PG53004	1231.5	1531.5		•		
PG53005	1303	1603	•	o	•	

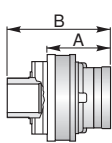
	PG ...FS					
	A	B	RA	RB	EF	EDF
PG53001	620	1170				
PG53002	903.5	1453.5				
PG53003	1124.5	1674.5				
PG53004	1231.5	1781.5		•		
PG53005	1303	1853	•	o	•	

	A	B	•
	A+13.5	B+13.5	o

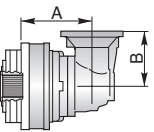
	PGA ...F					
	A	B	RA	RB	EF	
PGA53005	1366.5	315	•	o	•	

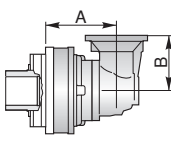
	PGA ...FS					
	A	B	RA	RB	EF	
PGA53005	1366.5	315	•	o	•	

	B	•
	B+16.5	o

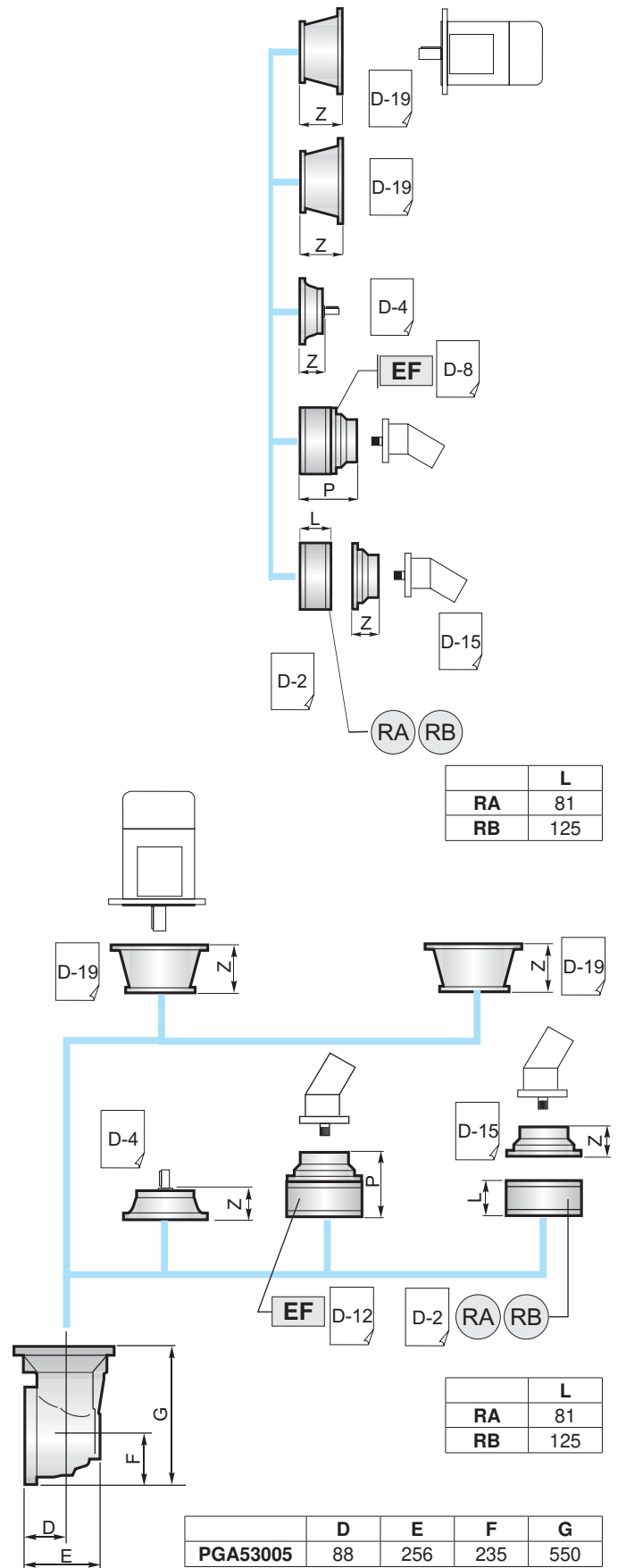

RA	L
RB	81
	125

RA	L
RB	81
	125

PGA53005	D	E	F	G
	88	256	235	550



61000

IT EN DE FR ES PT

	i	Mc [kNm]				n _{1max} [min ⁻¹]	Pt [kW]	Kg				
		n ₂ x h	n ₂ x h	n ₂ x h	n ₂ x h			M	P	CPC	F	FS
		10.000	20.000	50.000	100.000							
PG 61001	3.84	953.0	858.1	747.1	692.6	100	324	-	-	-	3200	3257
PG 61002	14.13	715.0	609.9	463.3	376.3	200	185	-	-	-	3710	3767
	18.97	514.7	463.5	403.5	363.4							
PG 61003	54.07	653.2	578.1	463.3	376.3	1200	129	-	-	-	3982	4039
	72.58	514.7	463.5	403.5	363.4							
PG 61004	216.27	653.2	578.1	463.3	376.3	2000	98	-	-	-	4041	4098
	281.15	653.2	578.1	463.3	376.3							
	290.32	514.7	463.5	403.5	363.4							
	337.92	506.8	448.6	381.8	337.8							
	377.41	514.7	463.5	403.5	363.4							
	453.62	514.7	463.5	403.5	363.4							
PG 61005	792.99	590.0	522.3	444.1	376.3	2800	81	-	-	-	4062	4119
	957.76	538.6	476.9	405.5	359.3							
	1030.88	653.2	578.1	463.3	376.3							
	1245.09	653.2	578.1	463.3	376.3							
	1405.75	587.4	520.0	442.4	376.3							
	1663.28	514.7	463.5	403.5	363.4							
	1887.06	514.7	463.5	403.5	363.4							
	1959.94	506.8	448.6	381.8	337.8							
	2631.00	514.7	463.5	403.5	363.4							
	3175.35	514.7	463.5	403.5	363.4							



	i	Mc [kNm]				n _{1max} [min ⁻¹]	Pt [kW]	Kg				
		n ₂ x h	n ₂ x h	n ₂ x h	n ₂ x h			M	P	CPC	F	FS
		10.000	20.000	50.000	100.000							
PGA 61005	863.53	541.2	439.7	334.1	271.5	2500	75	-	-	-	4163	4220
	1037.90	506.8	448.6	380.0	308.8							
	1159.20	514.7	463.5	403.5	333.6							
	1312.03	493.9	401.0	304.5	247.2							
	1393.26	514.7	463.5	403.5	363.4							
	1576.96	506.8	448.6	346.3	281.1							
	1761.26	514.7	463.5	374.1	303.8							
	2116.90	514.7	463.5	403.5	345.5							

(n₂ x h = 20.000)

$$M_{\max} = M_c \times 1.5$$

61000

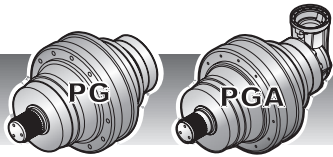

61000

IT EN DE FR ES PT

F

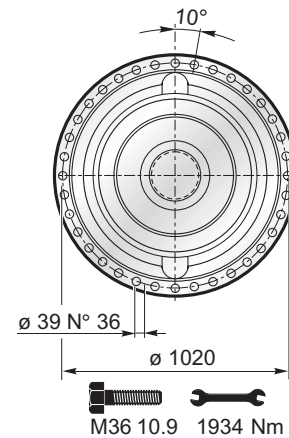
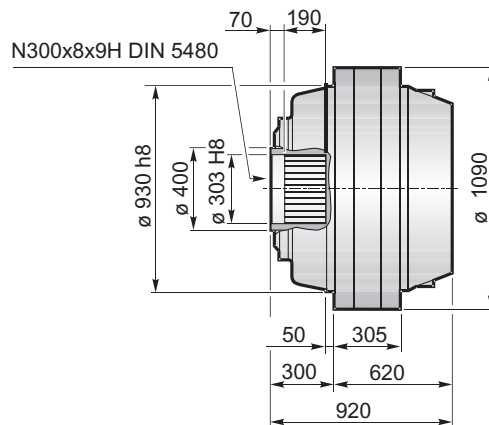

FS

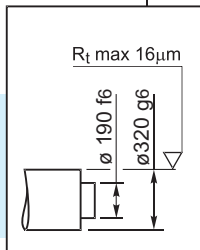
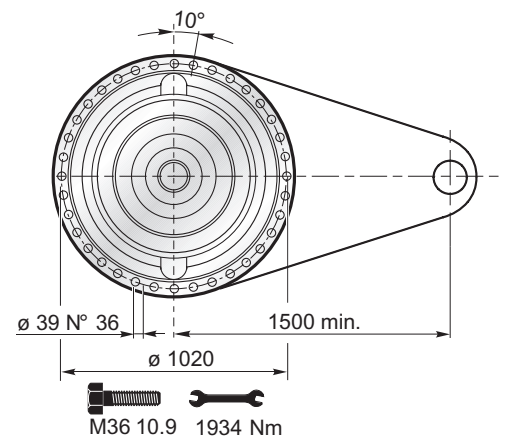
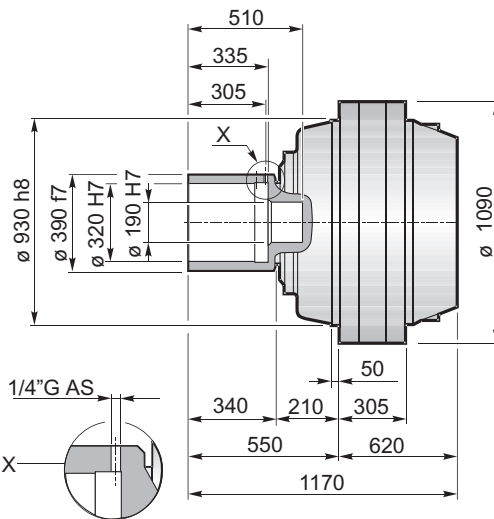

$M_{max} = 986 \text{ kNm}$

La coppia massima indicata è valida solo con calettatori forniti da Planetary Drives
 The maximum torque indicated is valid only with shrink discs supplied by Planetary Drives
 Das dargestellte, maximale Drehmoment gilt nur mit von Planetary Drives gelieferter Schrumpfscheibe
 Le couple maximal indiqué n'est valable qu'avec les frettes de serrage fournis par Planetary Drives
 El momento máximo indicado sólo es válido con discos de contracción suministrados por Planetary Drives
 O torque máximo indicado é válido exclusivamente com discos de contração fornecidos pela Planetary Drives

GA Giunto di attrito / Shrink disc
 Schrumpfscheibe / Frette de serrage
 Disco de contração / Disco de contração

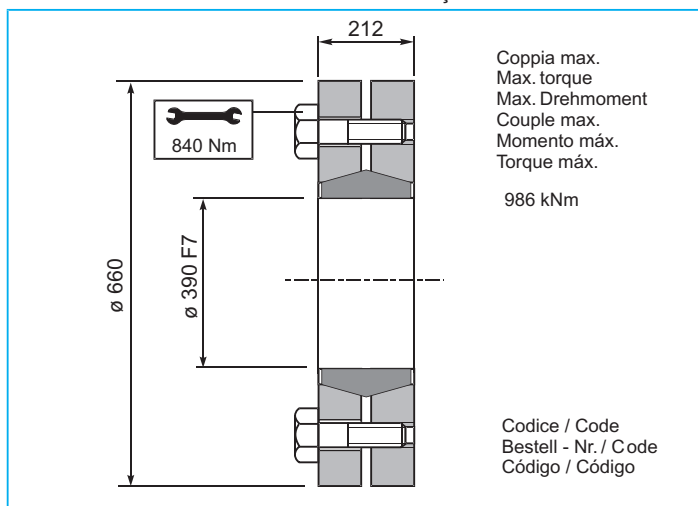

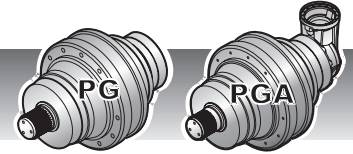

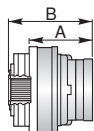
	PG ...F					
	A	B	RA	RB	EF	EDF
PG61001	620	920				
PG61002	903.5	1203.5				
PG61003	1124.5	1424.5				
PG61004	1231.5	1531.5		•		
PG61005	1303	1603	•	o	•	

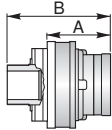
	PG ...FS					
	A	B	RA	RB	EF	EDF
PG61001	620	1170				
PG61002	903.5	1453.5				
PG61003	1124.5	1674.5				
PG61004	1231.5	1781.5		•		
PG61005	1303	1853	•	o	•	

	A	B	•
	A+13.5	B+13.5	o

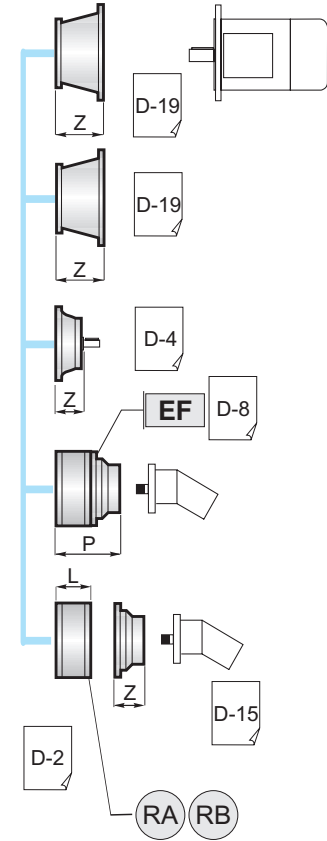

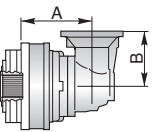
	PGA ...F					
	A	B	RA	RB	EF	
PGA61005	1366.5	315	•	o	•	

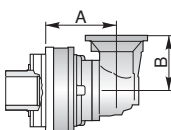
	PGA ...FS					
	A	B	RA	RB	EF	
PGA61005	1366.5	315	•	o	•	

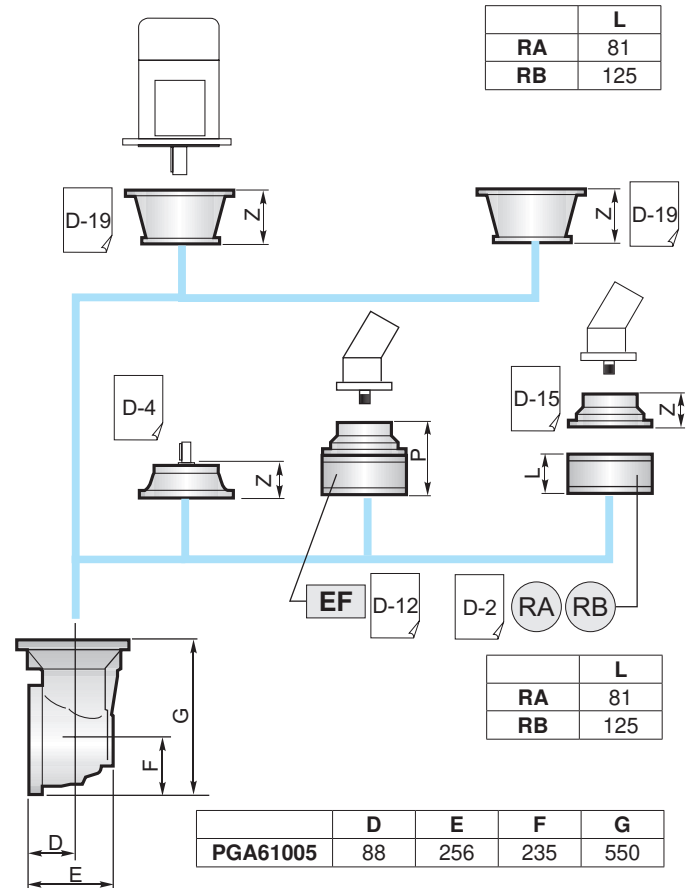

	B	•
	B+16.5	o



	L
RA	81
RB	125

	L
RA	81
RB	125

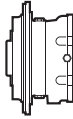
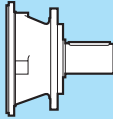
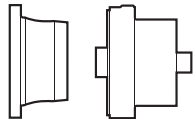
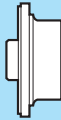
	D	E	F	G
PGA61005	88	256	235	550

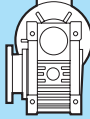
			
D		D-1	
		Freni modulari Modular brakes Bremsmodule Freins modulaires Frenos modulares Freios modulares	D-2
		Alberi entrata Input shafts Antriebswellen Arbre d'entrées Ejes de entrada Eixos de entrada	D-4
		Entrate dirette Direct inputs Standardantriebs Entrée directes Entradas directas Entradas diretas	D-8
		Predisposizioni per motori idraulici Hydraulic motor couplings Anbauvorrichtung fuer hydraulikmotore Adaptations pour moteurs hydraulique Acoplamientos para motores hidráulicos Predisposições para motores hidráulicos	D-16
		Predisposizioni per motori elettrici Electric motor couplings Anbauvorrichtung für Elektromotore Adaptations pour moteurs electriques Acoplamientos para motores eléctricos Predisposições para motores elétricos	D-19
		Predisposizioni per riduttori a vite senza fine Worm gearbox adaptors Anschluss für Schneckengetriebe Adaptation pour reducteurs a vis sans fin Acoplamiento para reductores de tornillo sin fin Predisposições para redutores de rosca sem fim	D-20

IT

FRENI MODULARI

I freni in dotazione ai riduttori epicicloidali Planetary Drives sono di tipo idraulico, con dischi a bagno d'olio, adatti esclusivamente alla fre- natura statica, ovvero di parcheggio.

I freni hanno la lubrificazione separata da quella del riduttore epicicloidale. In fase di immissione del lubrificante bisognerà quindi provvedere anche al riempimento del freno, mediante un apposito foro adduzione olio posto sullo stesso.

Il lubrificante consigliato è un ISO VG 32. Normalmente possono andar bene gli olii idraulici.

EN

MODULAR BRAKES

Planetary Drives planetary reduction units are equipped with hydraulic brakes with oil-bath disks, expressly designed for static or parking braking.

The lubrication for the brakes is separated from the lubrication of the planetary gear units. Thus, during the lubricant inlet phase, it is necessary to pour the fluid also into the brake through the proper hole mounted on its casing.

We suggest to use lubricant ISO VG 32 (however, hydraulic lubricants can be used as well).

DE

BREMSMODULE

Fuer die Planetary Drives - Planetengetriebe stehen hydraulische Federdruck-Lamellenbremsen zur Verfuegung.

Diese sind ausschliesslich als statische Haltebremsen ausgelegt. Die Lamellen liegen im Oelbad, das vom Oelkreislauf des Getriebes getrennt ist. Deshalb ist beim Befuellen darauf zu achten, dass der Schmierstoff direkt in den Bremskoerper gegeben wird.

In der Regel koennen Hydraulikoele verwendet werden. Empfohlener Schmierstoff: ISO VG 32.

FR

FREINS MODULAIRES

Les freins dont sont équipés les réducteurs planétaires Planetary Drives sont du type hydraulique, avec disques en bain d'huile, appropriés exclusivement pour le freinage statique, c'est à dire de stationnement.

Les freins ont une lubrification séparée de celle du réducteur planétaire. Lors de l'introduction du lubrifiant, il est donc nécessaire d'introduire de l'huile par le trou pratiqué sur le corps du frein.

Il est conseillé d'utiliser du lubrifiant ISO VG 32 (on peut utiliser normalement des huiles hydrauliques).

ES

FRENOS MODULARES

Los reductores epicicloidales Planetary Drives se suministran con frenos de tipo hidráulico, con discos sumergidos en baño de aceite, aptos exclusivamente para el frenado estático o sea, para el estacionamiento.

Los frenos tienen la lubricación separada del reductor epicicloidale. Por tanto, durante la introducción del lubricante también habrá que efectuar el llenado del freno, mediante el respectivo agujero de aducción de aceite que está en su carcasa.

Se aconseja utilizar el lubricante ISO VG 32 (también se pueden utilizar los aceites hidráulicos).

PT

FREIOS MODULARES

Os freios fornecidos com os reductores planetários Planetary Drives são do tipo hidráulico, com discos em banho de óleo, adequados exclusivamente para a frenagem estática, ou seja, de estacionamento.

A lubrificação dos freios é separada da lubrificação do reductor planetário. No momento de introduzir o lubrificante, é preciso abastecer também o freio através de um furo próprio de distribuição do óleo presente no mesmo.

O lubrificante aconselhado é um ISO VG 32. Normalmente, também podem ser utilizados os óleos hidráulicos.

PG	RA	PGA	RA
PG 100	1-2-3-4	PGA 100	2-3-4
PG 160	1-2-3-4	PGA 160	2-3-4
PG 250	1-2-3-4	PGA 250	2-3-4
PG 500	1-2-3-4	PGA 500	2-3-4
PG 700	2-3-4	PGA 700	2-3-4
PG 1000	2-3-4	PGA 1000	2-3-4
PG 1600	2-3-4	PGA 1600	3-4
PG 1800	3-4	PGA 1800	3-4
PG 2500	3-4	PGA 2500	3-4
PG 3000	3-4	PGA 3000	3-4
PG 3500	3-4	PGA 3500	3-4
PG 5000	3-4	PGA 5000	3-4
PG 6500	4	PGA 6500	4
PG 9000	4	PGA 9000	4
PG 12000	4-5	PGA 12000	4-5
PG 16000	4-5	PGA 16000	5
PG 21000	4-5	PGA 21000	5
PG 21000 H	4-5	PGA 21000 H	5
PG 26000	5	PGA 26000	5
PG 31000	5	PGA 31000	5
PG 31000 H	5	PGA 31000 H	—
PG 40000	5	PGA 40000	—
PG 45000	5	PGA 45000	—
PG 53000	5	PGA 53000	—
PG 61000	—	PGA 61000	—

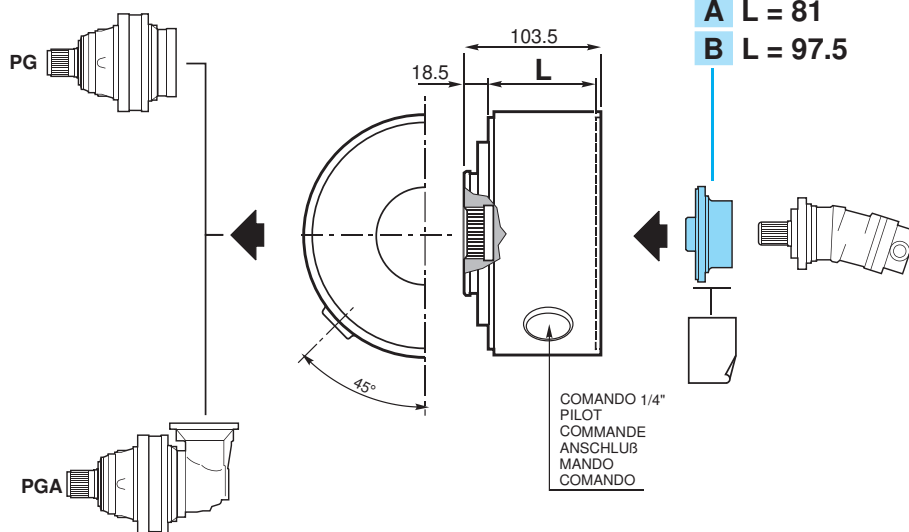

RA							
PG	Cfs _{min} [Nm]	Pa _{min} [bar]	Codice / Code Code / Bestell Nr.	P _{max} [bar]	OIL [lt]		Kg
					V1	B5	
RA 10	90	17	4706.000.500	300	0.4	0.2	14
RA 16	140	23	4706.001.500				
RA 25	220	19	4706.002.500				
RA 35	330	23	4706.003.500				
RA 45	430	33	4706.004.500				
RA 55	550	39	4706.006.500				

N.B.: i numeri 1-2-3-4-5 indicano il numero di stadi dei riduttori.

N.B.: Les numéros 1-2-3-4-5 indiquent le nombre d'étages des réducteurs.

N.B.: Numbers 1-2-3-4-5 refer to the number of stages of the planetary gear unit.

Nota: los números 1-2-3-4-5 indican el número de etapas de los reductores.

N.B. Die Ziffern 1-2-3-4-5 geben die Anzahl der Getriebestufen an.

OBS.: os números 1-2-3-4-5 indicam o número de estágios do reductor.

	RB
PG 100	—
PG 160	—
PG 250	1
PG 500	1
PG 700	1-2
PG 1000	1-2
PG 1600	1-2
PG 1800	2-3
PG 2500	2-3
PG 3000	2-3
PG 3500	2-3
PG 5000	2-3
PG 6500	3-4
PG 9000	3-4
PG 12000	3-4
PG 16000	3-4
PG 21000	3-4
PG 21000 H	4-5
PG 26000	4-5
PG 31000	4-5
PG 31000 H	4-5
PG 40000	4-5
PG 45000	4-5
PG 53000	4-5
PG 61000	5

	RB
PGA 100	—
PGA 160	—
PGA 250	—
PGA 500	—
PGA 700	—
PGA 1000	—
PGA 1600	2
PGA 1800	—
PGA 2500	2
PGA 3000	—
PGA 3500	2-3
PGA 5000	2
PGA 6500	3
PGA 9000	3
PGA 12000	3
PGA 16000	3-4
PGA 21000	3-4
PGA 21000 H	3-4
PGA 26000	4
PGA 31000	4
PGA 31000 H	4-5
PGA 40000	4-5
PGA 45000	5
PGA 53000	5
PGA 61000	5

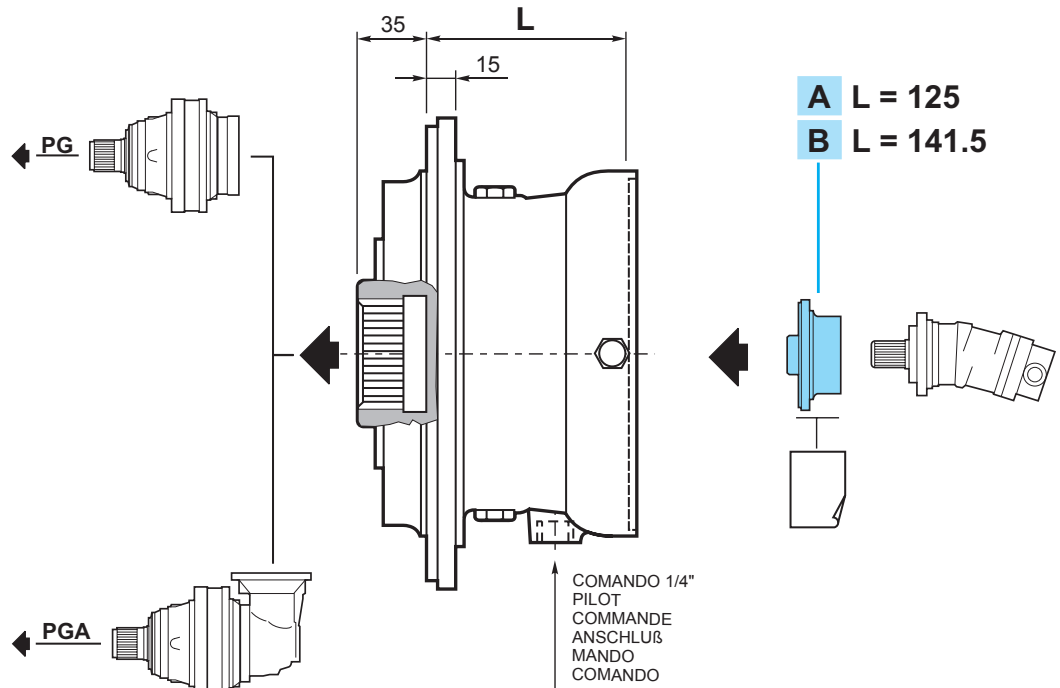

RB							
	Cfs _{min} [Nm]	Pa _{min} [bar]	Codice / Code Bestell Nr. / Code Código / Código	P _{max} [bar]	OIL [lt]		Kg
					V1	B5	
RB 25	250	22	4705.300.500	300	0.6	0.3	21
RB 40	400	35	4705.301.500				
RB 63	650	50	4705.302.500				
RB 80	800	38	4705.303.500				
RB 100	1000	45	4705.304.500				
RB 125	1250	45	4705.305.500				
RB 160	1500	45	4705.306.500				
RB 180	1700	50	4705.307.500				

N.B.: i numeri 1-2-3-4-5 indicano il numero di stadi dei riduttori.

N.B.: Numbers 1-2-3-4-5 refer to the number of stages of the planetary gear unit.

N.B. Die Ziffern 1-2-3-4-5 geben die Anzahl der Getriebestufen an.

N.B.: Les numéros 1-2-3-4-5 indiquent le nombre d'étages des réducteurs.

Nota: los números 1-2-3-4-5 indican el número de etapas de los reductores.

OBS.: os números 1-2-3-4-5 indicam o número de estágios do redutor

EL C 28

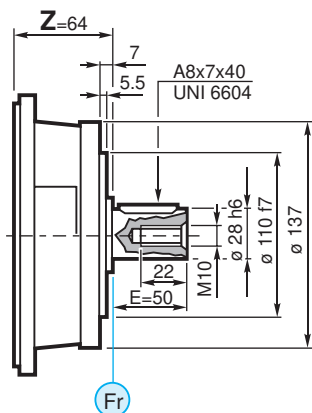

Peso
Weight
Gewicht
Poids
Peso
Peso

Kg 5.5

Codice / Code
Bestell - Nr. / Code
Código / Código

Nr. **4708.517.400**

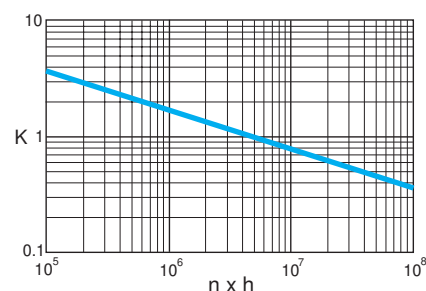
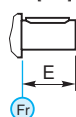
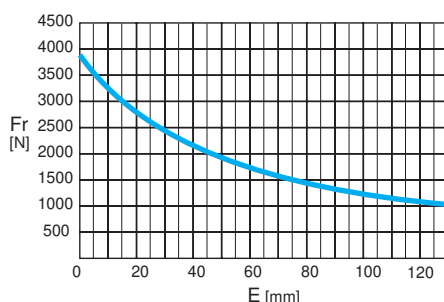

EL C 42

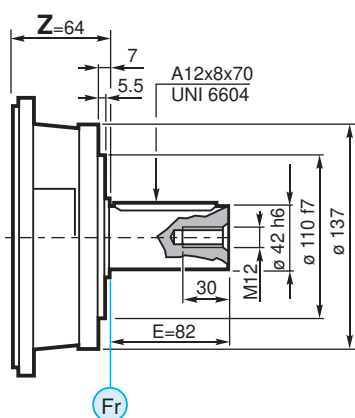

Peso
Weight
Gewicht
Poids
Peso
Peso

Kg 6.0

Codice / Code
Bestell - Nr. / Code
Código / Código

Nr. **4708.507.400**

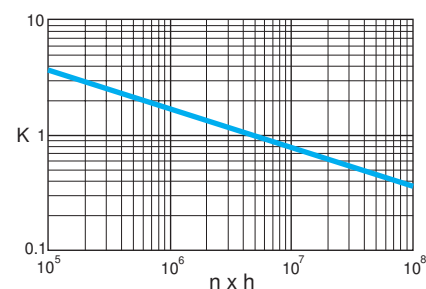
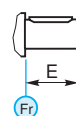
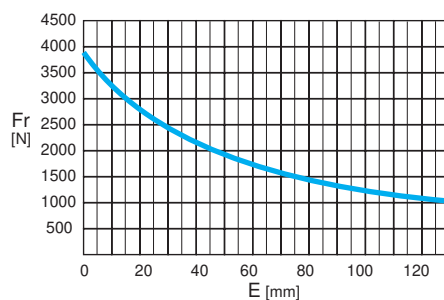

EML42

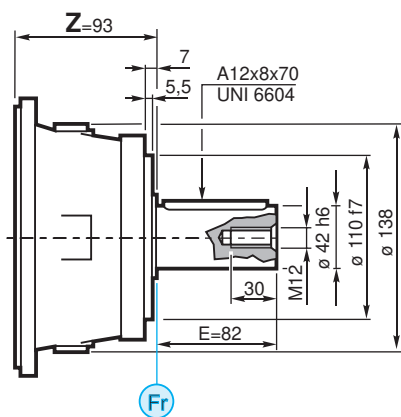

Peso
Weight
Gewicht
Poids
Peso
Peso

Kg 9.0

Codice / Code
Bestell - Nr. / Code
Código / Código

Nr. **4708.505.400**

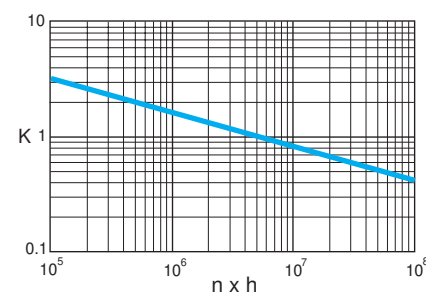
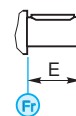
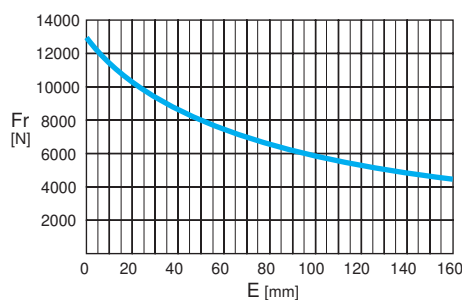

Le dimensioni Z riportate vanno verificate con la tabella a pag. D-7.
Z dimensions have to be verified in the table on page D-7.
Das Mass Z wird in der entsprechenden Tabelle auf der Seite D-7 festgestellt.
Les dimensions de Z sont à vérifier dans le tableau à page D-7.
Las dimensiones Z indicadas tienen que verificarse con la tabla de la Pág. D-7.
As dimensões Z indicadas devem ser verificadas com a tabela da pag. D-7.

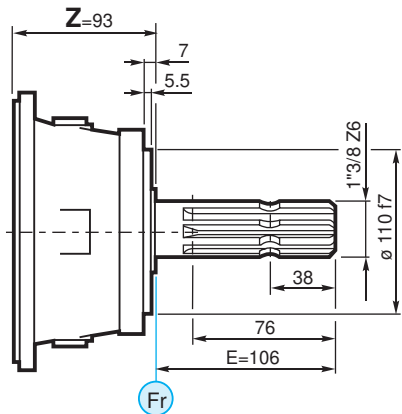

EML1"3/8 Z=6

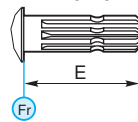
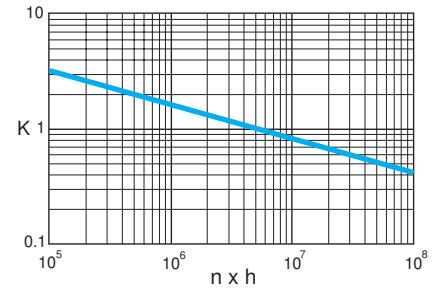
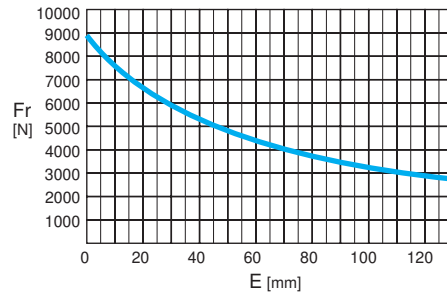

Peso
 Weight
 Gewicht
 Poids
 Peso
 Peso

Kg 9.0

Codice / Code
 Bestell - Nr. / Code
 Código / Código

Nr. **4708.508.400**

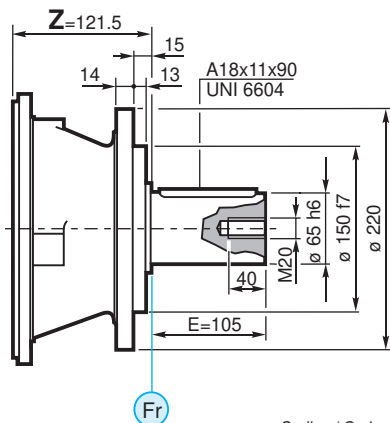

EM65

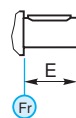
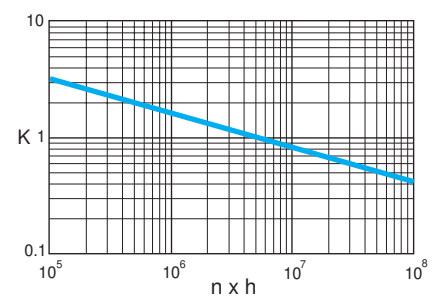
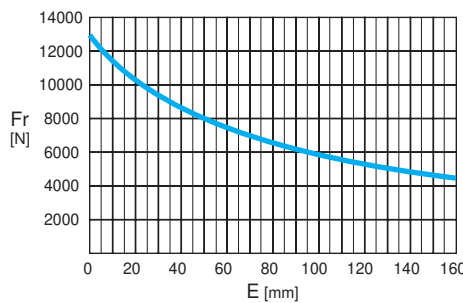

Peso
 Weight
 Gewicht
 Poids
 Peso
 Peso

Kg 17

Codice / Code
 Bestell - Nr. / Code
 Código / Código

Nr. **4712.501.400 (size < 1000)**
 Nr. **4714.501.400 (size > 1000)**

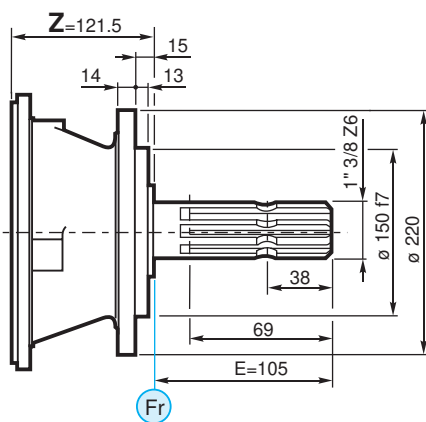

EM1"3/8 Z=6

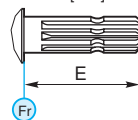
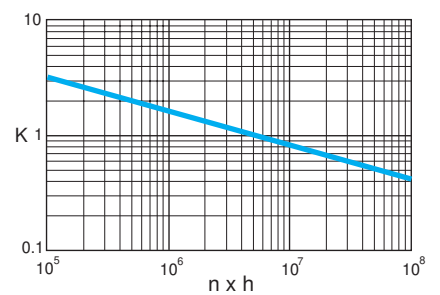
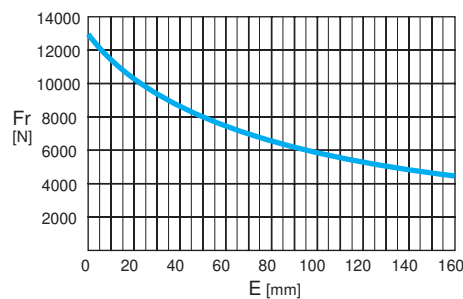

Peso
 Weight
 Gewicht
 Poids
 Peso
 Peso

Kg 17

Codice / Code
 Bestell - Nr. / Code
 Código / Código

Nr. **4712.505.400 (size < 1000)**
 Nr. **4714.504.400 (size > 1000)**

Le dimensioni Z riportate vanno verificate con la tabella a pag. D-7.
 Z dimensions have to be verified in the table on page D-7.
 Das Mass Z wird in der entsprechenden Tabelle auf der Seite D-7 festgestellt.
 Les dimensions de Z sont à vérifier dans le tableau à page D-7.
 Las dimensiones Z indicadas tienen que verificarse con la tabla de la Pág. D-7.
 As dimensões Z indicadas devem ser verificadas com a tabela da pag. D-7.



EP65

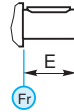
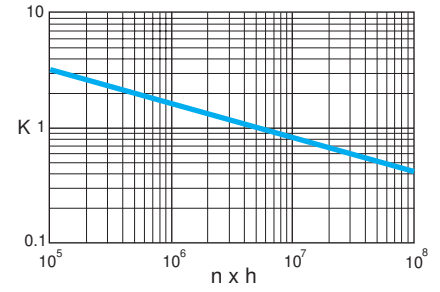
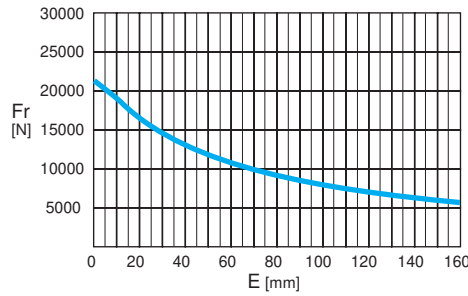
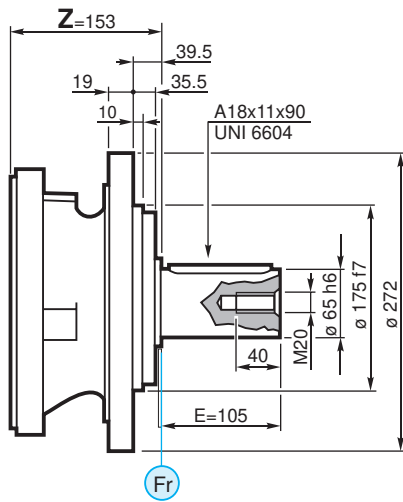

Peso
 Weight
 Gewicht
 Poids
 Peso
 Peso

Kg 26

Codice / Code
 Bestell - Nr. / Code
 Código / Código

Nr. **4712.503.400** (size < 1000)
 Nr. **4714.503.400** (size > 1000)

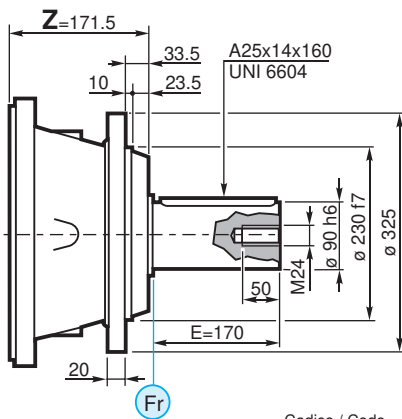

ET90

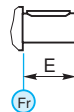
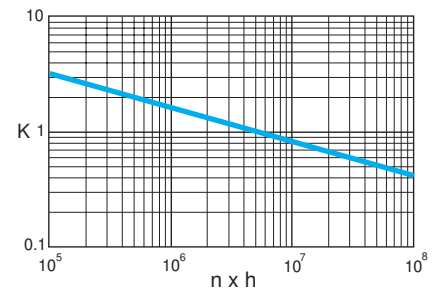
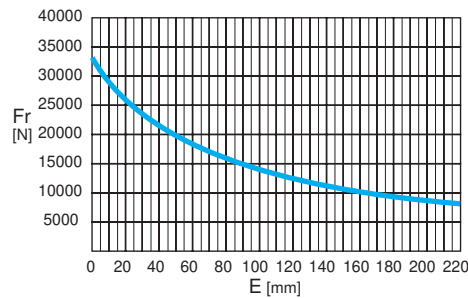



Peso
 Weight
 Gewicht
 Poids
 Peso
 Peso



Kg 48

Codice / Code
 Bestell - Nr. / Code
 Código / Código

Nr. **4716.500.400** (size < 2500)
 Nr. **4717.500.400** (size > 2500)

Le dimensioni Z riportate vanno verificate con la tabella a pag. D-7.
 Z dimensions have to be verified in the table on page D-7.
 Das Mass Z wird in der entsprechenden Tabelle auf der Seite D-7 festgestellt.
 Les dimensions de Z sont à vérifier dans le tableau à page D-7.
 Las dimensiones Z indicadas tienen que verificarse con la tabla de la Pág. D-7.
 As dimensões Z indicadas devem ser verificadas com a tabela da Pág. D-7.

							
		EL-EML	EM-EP		ET		
		Z	Z	Z+13.5	Z	Z+15	Z+31
PG 100	100	1-2-3-4	—	—	—	—	—
PG 160	160	1-2-3-4	—	—	—	—	—
PG 250	250	1-2-3-4	—	1	—	—	—
PG 500	500	1-2-3-4	—	1	—	—	—
PG 700	700	2-3-4	1	2	—	—	—
PG 1000	1000	2-3-4	1	2	—	—	—
PG 1600	1600	2-3-4	1	2	—	—	—
PG 1800	1800	3-4	2	3	—	—	—
PG 2500	2500	3-4	2	3	—	1	—
PG 3000	3000	3-4	2	3	—	—	2
PG 3500	3500	3-4	2	3	—	—	2
PG 5000	5000	3-4	2	3	1	—	2
PG 6500	6500	4	3	4	—	2	—
PG 9000	9000	4	3	4	—	2	—
PG 12000	12000	4-5	3	4	—	2	3
PG 16000	16000	4-5	3	4	2	—	3
PG 21000	21000	4-5	3	4	2	—	3
PG 21000 H	21000 H	5	4	5	—	3	—
PG 26000	26000	5	4	5	—	3	—
PG 31000	31000	5	4	5	—	3	—
PG 31000 H	31000 H	5	4	5	—	3	4
PG 40000	40000	5	4	5	—	3	4
PG 45000	45000	5	4	5	—	3	4
PG 53000	53000	5	4	5	3	—	4
PG 61000	61000	5	4	5	3	—	4

					
		EL-EML	EM-EP		ET
		Z	Z	Z+16	
PGA 100	100	2-3-4	—	—	—
PGA 160	160	2-3-4	—	—	—
PGA 250	250	2-3-4	—	2-3-4	—
PGA 500	500	2-3-4	—	2-3-4	—
PGA 700	700	2-3-4	—	2-3-4	—
PGA 1000	1000	2-3-4	—	2-3-4	—
PGA 1600	1600	3-4	2	3-4	—
PGA 1800	1800	3-4	—	3-4	—
PGA 2500	2500	3-4	2	3-4	—
PGA 3000	3000	4	—	3-4	—
PGA 3500	3500	4	2-3	4	—
PGA 5000	5000	4	—	2-3-4	—
PGA 6500	6500	4	2	3-4	—
PGA 9000	9000	4	2	3-4	—
PGA 12000	12000	4-5	3	4-5	—
PGA 16000	16000	5	3-4	5	—
PGA 21000	21000	5	3-4	5	—
PGA 21000 H	21000 H	5	3-4	5	—
PGA 26000	26000	5	4	5	—
PGA 31000	31000	5	4	5	—
PGA 31000 H	31000 H	—	4-5	—	—
PGA 40000	40000	—	4-5	—	—
PGA 45000	45000	—	5	—	—
PGA 53000	53000	—	5	—	—
PGA 61000	61000	—	5	—	—

N.B.: i numeri 1-2-3-4-5 indicano il numero di stadi dei riduttori.

N.B.: Numbers 1-2-3-4-5 refer to the number of stages of the planetary gear unit.

N.B. Die Ziffern 1-2-3-4-5 geben die Anzahl der Getriebestufen an.

N.B.: Les numéros 1-2-3-4-5 indiquent le nombre d'étages des réducteurs.

Nota: los números 1-2-3-4-5 indican el número de etapas de los reductores.

OBS.: os números 1-2-3-4-5 indicam o número de estágios do redutor.



ENTRATA DIRETTA SENZA FRENO CON ATTACCO MOTORE

Le tabelle seguenti indicano l'applicabilità delle entrate dirette EDF, EF sui riduttori PG, PGA.



DIRECT INPUT MOTOR ADAPTOR WITHOUT BRAKE

The following tables show how to apply direct inputs EDF, EF on PG, PGA planetary gear units.



STANDARDANTRIEB OHNE BREMSE MIT MOTORFLANSCH

Die nachfolgenden Tabellen zeigen die Anbaumöglichkeiten der EF- und EDF-Antriebe an die Getriebe der Serien PG und PGA.



ENTRÉE STANDARD SANS FREIN POUR ADAPTATION MOTEUR

Les tableaux ci-dessous montrent l'applicabilité des entrées standards EDF, EF aux réducteurs PG, PGA.



ENTRADAS DIRECTAS SIN FRENO PARA ACOPLAMIENTO MOTOR

Las siguientes tablas indican la factibilidad de aplicación de las entradas directas EDF, EF en los reductores PG, PGA.



ENTRADAS DIRETAS SEM FREIO COM ACOPLAMENTO AO MOTOR

As tabelas seguintes indicam a aplicabilidade das entradas diretas EDF, EF nos reductores PG, PGA.

PG 100	100	1-2-3-4
PG 160	160	1-2-3-4
PG 250	250	2-3-4
PG 500	500	2-3-4
PG 700	700	3-4
PG 1000	1000	3-4
PG 1600	1600	3-4
PG 1800	1800	4
PG 2500	2500	4
PG 3000	3000	4
PG 3500	3500	4
PG 5000	5000	4
PG 6500	6500	—
PG 9000	9000	—

PG 12000	12000	5
PG 16000	16000	5
PG 21000	21000	5
PG 21000 H	21000 H	—
PG 26000	26000	—
PG 31000	31000	—
PG 31000 H	31000 H	—
PG 40000	40000	—
PG 45000	45000	—
PG 53000	53000	—
PG 61000	61000	—

N.B.: i numeri 1-2-3-4-5 indicano il numero di stadi dei riduttori.
 N.B.: Numbers 1-2-3-4-5 refer to the number of stages of the planetary gear unit.
 N.B.: Die Ziffern 1-2-3-4-5 geben die Anzahl der Getriebestufen an.
 N.B.: Les numéros 1-2-3-4-5 indiquent le nombre d'étages des réducteurs.
 Nota: los números 1-2-3-4-5 indican el número de etapas de los reductores.
 OBS.: os números 1-2-3-4-5 indicam o número de estágios do redutor.

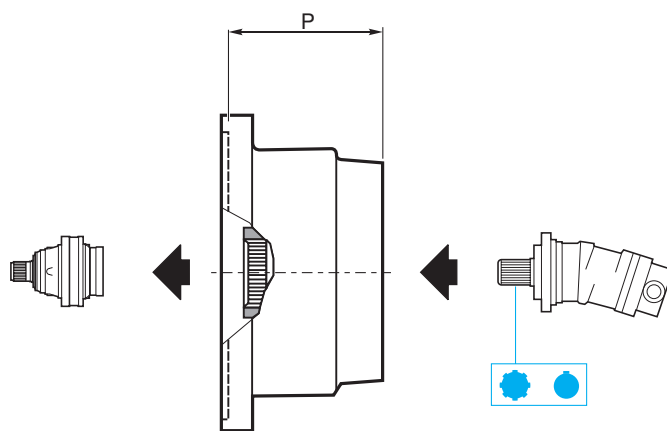

ED		
	P	Codice / Code Bestell Nr. / Code Código / Código
ED SAE A 2-4 F 16/32 DP 9TH	89	4708.550.700
ED SAE A 2-4 F 16/32 DP 13TH	89	4708.551.700
ED SAE A 2-4 F 12/24 DP 14TH	105	4708.552.700
ED SAE A 2-4 F 12/24 DP 14TH	105	4708.553.700
ED SAE A 2-4 F 1" 6B	89	4708.554.700
ED SAE A 2-4 F 1" 6B	105	4708.555.700
ED SAE A 2-4 F 25x22 DIN 5482	89	4708.556.700



ED		
	P	Codice / Code Bestell Nr. / Code Código / Código
ED SAE A 2-4 F D. 19.5 CH 4.8	89	4708.530.700
ED SAE A 2-4 F D. 25 CH 8	89	4708.531.700
ED SAE A 2-4 F D. 25.4 CH 6.35	89	4708.532.700
ED SAE A 2-4 F D. 25.4 CH 6.35	105	4708.533.700
ED SAE A 2-4 F D. 31.75 CH 7.96	89	4708.534.700
ED SAE A 2-4 F D. 31.75 CH 7.96	105	4708.535.700
ED SAE A 2-4 F D. 32 CH 10	105	4708.536.700

**ENTRATA DIRETTA
CON FRENO E ATTACCO
MOTORE**



**DIRECT INPUT MOTOR
ADAPTOR WITH BRAKE**



**MOTORFLANSCH MIT
INTEGRIERTER BREMSE**



Le tabelle seguenti indicano l'applicabilità delle entrate dirette EDF, EF sui riduttori PG, PGA.

The following tables show how to apply direct inputs EDF, EF on PG, PGA planetary gear units

Die nachfolgenden Tabellen zeigen die Anbaumöglichkeiten der EF- und EDF-Antriebe an die Getriebe der Serien PG und PGA

**ENTRÉE DIRECTE AVEC
FREIN POUR ADAPTATION
MOTEUR**



**ENTRADAS DIRECTAS CON
FRENO PARA
ACOPLAMIENTO MOTOR**



**ENTRADAS DIRETAS COM
FREIO E ACOPLAMENTO AO
MOTOR**



Le tabelle seguenti indicano l'applicabilità delle entrate dirette EDF, EF sui riduttori PG, PGA.

Las siguientes tablas indican la factibilidad de aplicación de las entradas directas EDF, EF en los reductores PG, PGA.

As tabelas seguintes indicam a aplicabilidade das entradas diretas EDF, EF nos reductores PG, PGA.

PG	100	ED	
		ED	EDF
PG 100	100	—	1-2-3-4
PG 160	160	—	1-2-3-4
PG 250	250	1	2-3-4
PG 500	500	1	2-3-4
PG 700	700	2	3-4
PG 1000	1000	2	3-4
PG 1600	1600	2	3-4
PG 1800	1800	3	4
PG 2500	2500	3	4
PG 3000	3000	3	4
PG 3500	3500	3	4
PG 5000	5000	3	4
PG 6500	6500	4	—
PG 9000	9000	4	—

PG	12000	ED	
		ED	EDF
PG 12000	12000	4	5
PG 16000	16000	4	5
PG 21000	21000	4	5
PG 21000 H	21000 H	5	—
PG 26000	26000	5	—
PG 31000	31000	5	—
PG 31000 H	31000 H	5	—
PG 40000	40000	5	—
PG 45000	45000	5	—
PG 53000	53000	5	—
PG 61000	61000	—	—

PGA	100	ED	
		ED	EDF
PGA 100	100	2-3-4	—
PGA 160	160	2-3-4	—
PGA 250	250	2-3-4	—
PGA 500	500	2-3-4	—
PGA 700	700	2-3-4	—
PGA 1000	1000	2-3-4	—
PGA 1600	1600	3-4	—
PGA 1800	1800	3-4	—
PGA 2500	2500	3-4	—
PGA 3000	3000	3-4	—
PGA 3500	3500	4	—
PGA 5000	5000	4	—
PGA 6500	6500	4	—
PGA 9000	9000	4	—

PGA	12000	ED	
		ED	EDF
PGA 12000	12000	4-5	—
PGA 16000	16000	5	—
PGA 21000	21000	5	—
PGA 21000 H	21000 H	5	—
PGA 26000	26000	5	—
PGA 31000	31000	5	—
PGA 31000 H	31000 H	—	—
PGA 40000	40000	—	—
PGA 45000	45000	—	—
PGA 53000	53000	—	—
PGA 61000	61000	—	—

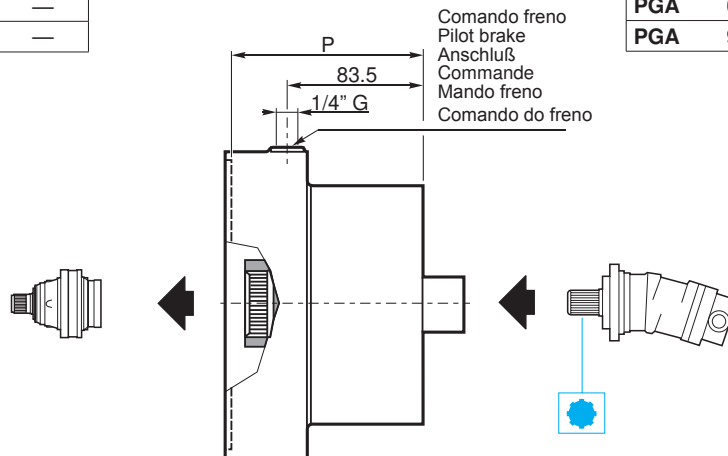

EDF	Cfs _{min} [Nm]	Pa _{min} [bar]	P	Codice / Code Bestell Nr. / Code Código / Código	P _{max} [bar]	OIL [lt]		Kg
						V1	B5	
EDF 10 per/for GLC-OMSS-HPRC	110	13	118	4708.100.710	300	0.3	0.15	20
EDF 16 per/for GLC-OMSS-HPRC	160	17	118	4708.101.710				
EDF 20 per/for GLC-OMSS-HPRC	220	23	118	4708.102.710				
EDF 25 per/for GLC-OMSS-HPRC	260	17	118	4708.103.710				
EDF 35 per/for GLC-OMSS-HPRC	360	17	118	4708.104.710				
EDF 45 per/for GLC-OMSS-HPRC	470	23	118	4708.105.710				
EDF 55 per/for GLC-OMSS-HPRC	600	27	118	4708.106.710				

EDF	Cfs _{min} [Nm]	Pa _{min} [bar]	P	Codice / Code Bestell Nr. / Code Código / Código	P _{max} [bar]	OIL [lt]		Kg
						V1	B5	
EDF 10 per/for EATON 2000 BEARINGLESS	110	13	118	A richiesta On request Auf Anfrage Sur demande Bajo demanda Sob consulta	300	0.3	0.15	20
EDF 16 per/for EATON 2000 BEARINGLESS	160	17	118					
EDF 20 per/for EATON 2000 BEARINGLESS	220	23	118					
EDF 25 per/for EATON 2000 BEARINGLESS	260	17	118					
EDF 35 per/for EATON 2000 BEARINGLESS	360	17	118					
EDF 45 per/for EATON 2000 BEARINGLESS	470	23	118					
EDF 55 per/for EATON 2000 BEARINGLESS	600	27	118					



**ENTRATA DIRETTA
CON FRENO E ATTACCO
MOTORE**

Le tabelle seguenti indicano l'applicabilità delle entrate dirette EDF, EF sui riduttori PG, PGA.



**DIRECT INPUT MOTOR
ADAPTOR WITH BRAKE**

The following tables show how to apply direct inputs EDF, EF on PG, PGA planetary gear units.



**MOTORFLANSCH MIT
INTEGRIERTER BREMSE**

Die nachfolgenden Tabellen zeigen die Anbaumöglichkeiten der EF- und EDF-Antriebe an die Getriebe der Serien PG und PGA.



**ENTRÉE DIRECTE AVEC
FREIN POUR ADAPTATION
MOTEUR**

Les tableaux ci-dessous montrent l'applicabilité des entrées standards EDF, EF aux réducteurs PG, PGA.



**ENTRADAS DIRECTAS CON
FRENO PARA
ACOPLAMIENTO MOTOR**

Las siguientes tablas indican la factibilidad de aplicación de las entradas directas EDF, EF en los reductores PG, PGA.



**ENTRADAS DIRETAS COM
FREIO E ACOPLAMENTO AO
MOTOR**

As tabelas seguintes indicam a aplicabilidade das entradas diretas EDF, EF nos reductores PG, PGA.

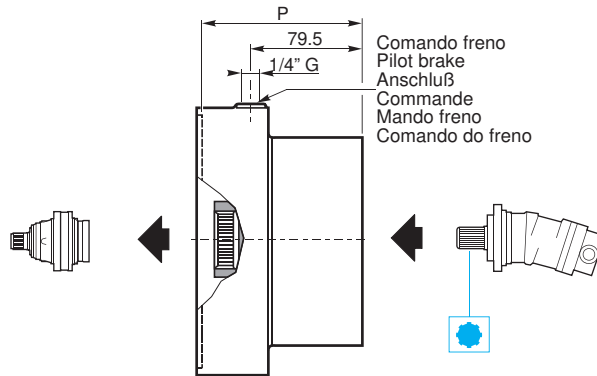

EDF								
	Cfs _{min} [Nm]	Pa _{min} [bar]	P	Codice / Code Bestell Nr. / Code Código / Código.	P _{max} [bar]	OIL [lt]		Kg
						V1	B5	
EDF 10 SAE A 2-4 F 16/32 DP 9TH	110	13	114	A richiesta On request Auf Anfrage Sur demande Bajo demanda Sob consulta	300	0.3	0.15	20
EDF 16 SAE A 2-4 F 16/32 DP 9TH	160	17	114					
EDF 20 SAE A 2-4 F 16/32 DP 9TH	220	23	114					
EDF 25 SAE A 2-4 F 16/32 DP 9TH	260	17	114					
EDF 25 SAE A 2-4 F 16/32 DP 9TH	360	17	114					
EDF 45 SAE A 2-4 F 16/32 DP 9TH	470	23	114					
EDF 55 SAE A 2-4 F 16/32 DP 9TH	600	27	114					

EDF								
	Cfs _{min} [Nm]	Pa _{min} [bar]	P	Codice / Code Bestell Nr. / Code Código / Código.	P _{max} [bar]	OIL [lt]		Kg
						V1	B5	
EDF 10 SAE A 2-4 F 16/32 DP 13TH	110	13	114	A richiesta On request Auf Anfrage Sur demande Bajo demanda Sob consulta	300	0.3	0.15	20
EDF 16 SAE A 2-4 F 16/32 DP 13TH	160	17	114					
EDF 20 SAE A 2-4 F 16/32 DP 13TH	220	23	114					
EDF 25 SAE A 2-4 F 16/32 DP 13TH	260	17	114					
EDF 35 SAE A 2-4 F 16/32 DP 13TH	360	17	114					
EDF 45 SAE A 2-4 F 16/32 DP 13TH	470	23	114					
EDF 55 SAE A 2-4 F 16/32 DP 13TH	600	27	114					

EDF								
	Cfs _{min} [Nm]	Pa _{min} [bar]	P	Codice / Code Bestell Nr. / Code Código / Código.	P _{max} [bar]	OIL [lt]		Kg
						V1	B5	
EDF 10 SAE A 2-4 F 12/24 DP 14TH	110	13	114	A richiesta On request Auf Anfrage Sur demande Bajo demanda Sob consulta	300	0.3	0.15	20
EDF 16 SAE A 2-4 F 12/24 DP 14TH	160	17	114					
EDF 20 SAE A 2-4 F 12/24 DP 14TH	220	23	114					
EDF 25 SAE A 2-4 F 12/24 DP 14TH	260	17	114					
EDF 35 SAE A 2-4 F 12/24 DP 14TH	360	17	114					
EDF 45 SAE A 2-4 F 12/24 DP 14TH	470	23	114					
EDF 55 SAE A 2-4 F 12/24 DP 14TH	600	27	114					

EDF								
	Cfs _{min} [Nm]	Pa _{min} [bar]	P	Codice / Code Bestell Nr. / Code Código / Código.	P _{max} [bar]	OIL [lt]		Kg
						V1	B5	
EDF 10 SAE A 2-4 F 1" 6B	110	13	114	4708.080.710	300	0.3	0.15	20
EDF 16 SAE A 2-4 F 1" 6B	160	17	114	4708.081.710				
EDF 20 SAE A 2-4 F 1" 6B	220	23	114	4708.082.710				
EDF 25 SAE A 2-4 F 1" 6B	260	17	114	4708.083.710				
EDF 35 SAE A 2-4 F 1" 6B	360	17	114	4708.084.710				
EDF 45 SAE A 2-4 F 1" 6B	470	23	114	4708.085.710				
EDF 55 SAE A 2-4 F 1" 6B	600	27	114	4708.086.710				

ENTRATE DIRETTE
CON FRENO E ATTACCO
MOTORE



DIRECT INPUT MOTOR
ADAPTOR WITH BRAKE



MOTORFLANSCH MIT
INTEGRIERTER BREMSE



ENTRÉE DIRECTE AVEC
FREIN POUR ADAPTATION
MOTEUR





ENTRADAS DIRECTAS CON
FRENO PARA
ACOPLAMIENTO MOTOR



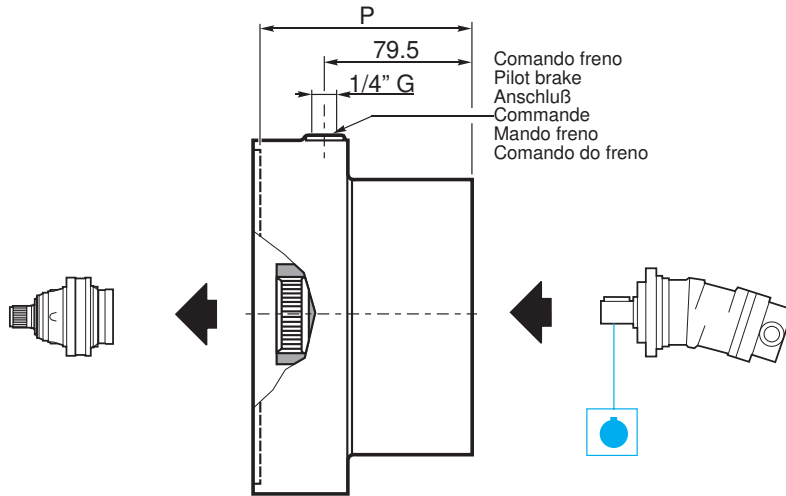

ENTRADAS DIRETAS COM
FREIO E ACOPLAMENTO
AO MOTOR



EDF								
	Cfs _{min} [Nm]	Pa _{min} [bar]	P	Codice / Code Bestell Nr. / Code Código / Código	P _{max} [bar]	OIL [lt]		Kg
						V1	B5	
EDF 10 SAE A 2-4 F D. 25 CH 8	110	13	114	4708.010.710	300	0.3	0.15	20
EDF 16 SAE A 2-4 F D. 25 CH 8	160	17	114	4708.011.710				
EDF 20 SAE A 2-4 F D. 25 CH 8	220	23	114	4708.012.710				
EDF 25 SAE A 2-4 F D. 25 CH 8	260	17	114	4708.013.710				
EDF 35 SAE A 2-4 F D. 25 CH 8	360	17	114	4708.014.710				
EDF 45 SAE A 2-4 F D. 25 CH 8	470	23	114	4708.015.710				
EDF 55 SAE A 2-4 F D. 25 CH 8	600	27	114	4708.016.710				

EDF								
	Cfs _{min} [Nm]	Pa _{min} [bar]	P	Codice / Code Bestell Nr. / Code Código / Código	P _{max} [bar]	OIL [lt]		Kg
						V1	B5	
EDF 10 SAE A 2-4 F D. 25.4 CH 6.35	110	13	114	A richiesta On request Auf Anfrage Sur demande Bajo demanda Sob consulta	300	0.3	0.15	20
EDF 16 SAE A 2-4 F D. 25.4 CH 6.35	160	17	114					
EDF 20 SAE A 2-4 F D. 25.4 CH 6.35	220	23	114					
EDF 25 SAE A 2-4 F D. 25.4 CH 6.35	260	17	114					
EDF 35 SAE A 2-4 F D. 25.4 CH 6.35	360	17	114					
EDF 45 SAE A 2-4 F D. 25.4 CH 6.35	470	23	114					
EDF 55 SAE A 2-4 F D. 25.4 CH 6.35	600	27	114					

EDF								
	Cfs _{min} [Nm]	Pa _{min} [bar]	P	Codice / Code Bestell Nr. / Code Código / Código	P _{max} [bar]	OIL [lt]		Kg
						V1	B5	
EDF 10 SAE A 2-4 F D. 31.75 CH 7.96	110	13	114	A richiesta On request Auf Anfrage Sur demande Bajo demanda Sob consulta	300	0.3	0.15	20
EDF 16 SAE A 2-4 F D. 31.75 CH 7.96	160	17	114					
EDF 20 SAE A 2-4 F D. 31.75 CH 7.96	220	23	114					
EDF 25 SAE A 2-4 F D. 31.75 CH 7.96	260	17	114					
EDF 35 SAE A 2-4 F D. 31.75 CH 7.96	360	17	114					
EDF 45 SAE A 2-4 F D. 31.75 CH 7.96	470	23	114					
EDF 55 SAE A 2-4 F D. 31.75 CH 7.96	600	27	114					

EDF								
	Cfs _{min} [Nm]	Pa _{min} [bar]	P	Codice / Code Bestell Nr. / Code Código / Código	P _{max} [bar]	OIL [lt]		Kg
						V1	B5	
EDF 10 SAE A 2-4 F D. 32 CH 10	110	13	114	4708.040.710	300	0.3	0.15	20
EDF 16 SAE A 2-4 F D. 32 CH 10	160	17	114	4708.041.710				
EDF 20 SAE A 2-4 F D. 32 CH 10	220	23	114	4708.042.710				
EDF 25 SAE A 2-4 F D. 32 CH 10	260	17	114	4708.043.710				
EDF 35 SAE A 2-4 F D. 32 CH 10	360	17	114	4708.044.710				
EDF 45 SAE A 2-4 F D. 32 CH 10	470	23	114	4708.045.710				
EDF 55 SAE A 2-4 F D. 32 CH 10	600	27	114	4708.046.710				

ACC.



**ENTRATA DIRETTE
CON FRENO E ATTACCO
MOTORE**



**DIRECT INPUT MOTOR
ADAPTOR WITH BRAKE**



**MOTORFLANSCH MIT
INTEGRIERTER BREMSE**



**ENTRÉE DIRECTE AVEC
FREIN POUR ADAPTATION
MOTEUR**





**ENTRADAS DIRECTAS CON
FRENO PARA
ACOPLAMIENTO MOTOR**

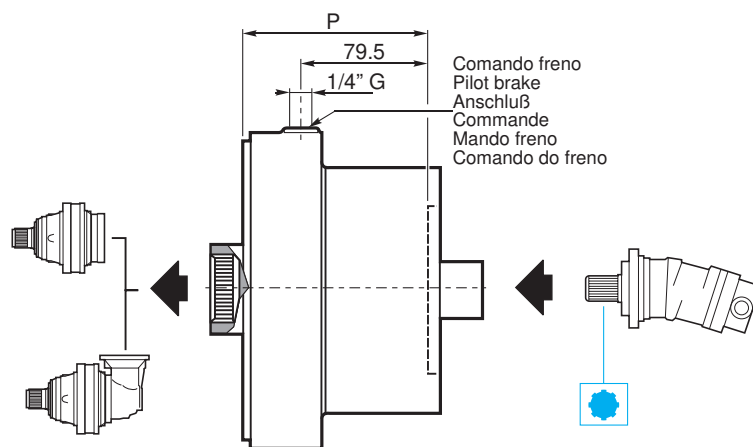

**ENTRADAS DIRETAS COM
FREIO E ACOPLAMENTO AO
MOTOR**



EF								
	Cfs _{min} [Nm]	Pa _{min} [bar]	P	Codice / Code Bestell Nr. / Code Código / Código	P _{max} [bar]	OIL [lt]		Kg
						V1	B5	
EF 10 per/for GLC-OMSS-HPRC	110	13	118	4702.015.060	300	0.3	0.15	20
EF 16 per/for GLC-OMSS-HPRC	160	17	118	4702.015.061				
EF 20 per/for GLC-OMSS-HPRC	220	23	118	4702.015.062				
EF 25 per/for GLC-OMSS-HPRC	260	17	118	4702.015.063				
EF 35 per/for GLC-OMSS-HPRC	360	17	118	4702.015.064				
EF 45 per/for GLC-OMSS-HPRC	470	23	118	4702.015.065				
EF 55 per/for GLC-OMSS-HPRC	600	27	118	4702.015.066				

EF								
	Cfs _{min} [Nm]	Pa _{min} [bar]	P	Codice / Code Bestell Nr. / Code Código / Código	P _{max} [bar]	OIL [lt]		Kg
						V1	B5	
EF 10 per/for EATON 2000 BEARINGLESS	110	13	118	A richiesta On request Auf Anfrage Sur demande Bajo demanda Sob consulta	300	0.3	0.15	20
EF 16 per/for EATON 2000 BEARINGLESS	160	17	118					
EF 20 per/for EATON 2000 BEARINGLESS	220	23	118					
EF 25 per/for EATON 2000 BEARINGLESS	260	17	118					
EF 35 per/for EATON 2000 BEARINGLESS	360	17	118					
EF 45 per/for EATON 2000 BEARINGLESS	470	23	118					
EF 55 per/for EATON 2000 BEARINGLESS	600	27	118					

ENTRATE DIRETTE
CON FRENO E ATTACCO
MOTORE



DIRECT INPUT MOTOR
ADAPTOR WITH BRAKE



MOTORFLANSCH MIT
INTEGRIERTER BREMSE



ENTRÉE DIRECTE AVEC
FREIN POUR ADAPTATION
MOTEUR



ENTRADAS DIRECTAS CON
FRENO PARA
ACOPLAMIENTO MOTOR



ENTRADAS DIRETAS COM
FREIO E ACOPLAMENTO
AO MOTOR

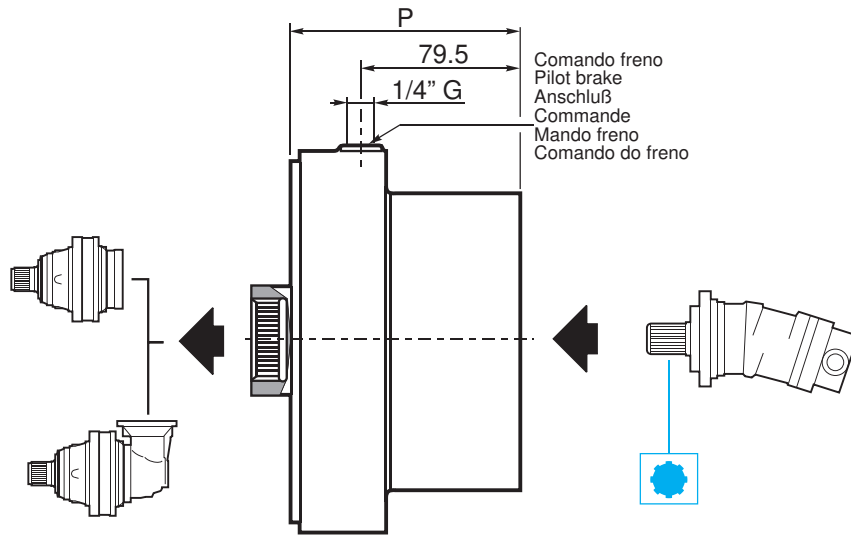

Comando freno
Pilot brake
Anschluß
Commande
Mando freno
Comando do freno



EF								
	Cfs _{min} [Nm]	Pa _{min} [bar]	P	Codice / Code Bestell Nr. / Code Código / Código	P _{max} [bar]	OIL [lt]		Kg
						V1	B5	
EF 10 SAE A 2-4 F 16/32 DP 9TH	110	13	114	A richiesta On request Auf Anfrage Sur demande Bajo demanda Sob consulta	300	0.3	0.15	20
EF 16 SAE A 2-4 F 16/32 DP 9TH	160	17	114					
EF 20 SAE A 2-4 F 16/32 DP 9TH	220	23	114					
EF 25 SAE A 2-4 F 16/32 DP 9TH	260	17	114					
EF 35 SAE A 2-4 F 16/32 DP 9TH	360	17	114					
EF 45 SAE A 2-4 F 16/32 DP 9TH	470	23	114					
EF 55 SAE A 2-4 F 16/32 DP 9TH	600	27	114					

EF								
	Cfs _{min} [Nm]	Pa _{min} [bar]	P	Codice / Code Bestell Nr. / Code Código / Código	P _{max} [bar]	OIL [lt]		Kg
						V1	B5	
EF 10 SAE A 2-4 F 16/32 DP 13TH	110	13	114	A richiesta On request Auf Anfrage Sur demande Bajo demanda Sob consulta	300	0.3	0.15	20
EF 16 SAE A 2-4 F 16/32 DP 13TH	160	17	114					
EF 20 SAE A 2-4 F 16/32 DP 13TH	220	23	114					
EF 25 SAE A 2-4 F 16/32 DP 13TH	260	17	114					
EF 35 SAE A 2-4 F 16/32 DP 13TH	360	17	114					
EF 45 SAE A 2-4 F 16/32 DP 13TH	470	23	114					
EF 55 SAE A 2-4 F 16/32 DP 13TH	600	27	114					

EF								
	Cfs _{min} [Nm]	Pa _{min} [bar]	P	Codice / Code Bestell Nr. / Code Código / Código	P _{max} [bar]	OIL [lt]		Kg
						V1	B5	
EF 10 SAE A 2-4 F 12/24 DP 14TH	110	13	114	A richiesta On request Auf Anfrage Sur demande Bajo demanda Sob consulta	300	0.3	0.15	20
EF 16 SAE A 2-4 F 12/24 DP 14TH	160	17	114					
EF 20 SAE A 2-4 F 12/24 DP 14TH	220	23	114					
EF 25 SAE A 2-4 F 12/24 DP 14TH	260	17	114					
EF 35 SAE A 2-4 F 12/24 DP 14TH	360	17	114					
EF 45 SAE A 2-4 F 12/24 DP 14TH	470	23	114					
EF 55 SAE A 2-4 F 12/24 DP 14TH	600	27	114					

EF								
	Cfs _{min} [Nm]	Pa _{min} [bar]	P	Codice / Code Bestell Nr. / Code Código / Código	P _{max} [bar]	OIL [lt]		Kg
						V1	B5	
EF 10 SAE A 2-4 F 1" 6B	110	13	114	4702.015.040	300	0.3	0.15	20
EF 16 SAE A 2-4 F 1" 6B	160	17	114	4702.015.041				
EF 20 SAE A 2-4 F 1" 6B	220	23	114	4702.015.042				
EF 25 SAE A 2-4 F 1" 6B	260	17	114	4702.015.043				
EF 35 SAE A 2-4 F 1" 6B	360	17	114	4702.015.044				
EF 45 SAE A 2-4 F 1" 6B	470	23	114	4702.015.045				
EF 55 SAE A 2-4 F 1" 6B	600	27	114	4702.015.046				

ACC.



**ENTRATE DIRETTE
CON FRENO E ATTACCO
MOTORE**



**DIRECT INPUT MOTOR
ADAPTOR WITH BRAKE**



**MOTORFLANSCH MIT
INTEGRIERTER BREMSE**



**ENTRÉE DIRECTE AVEC
FREIN POUR ADAPTATION
MOTEUR**



**ENTRADAS DIRECTAS CON
FRENO PARA
ACOPLAMIENTO MOTOR**



**ENTRADAS DIRETAS COM
FREIO E ACOPLAMENTO AO
MOTOR**

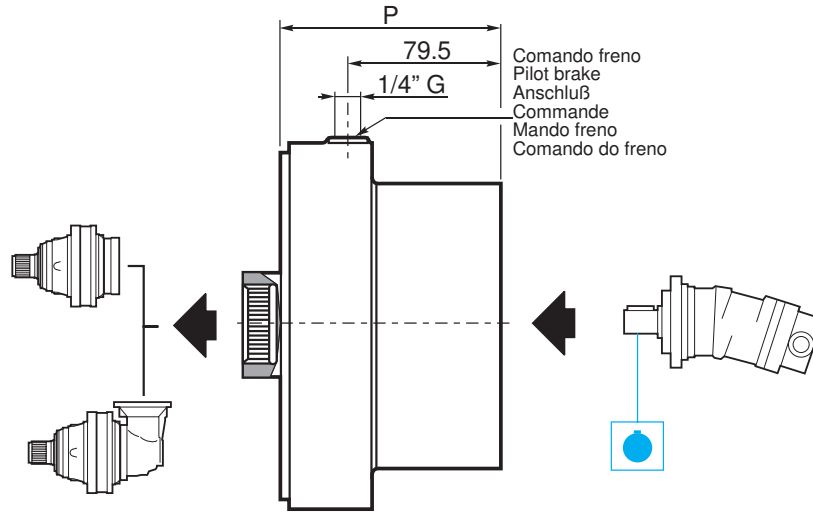



EF								
	Cfs _{min} [Nm]	Pa _{min} [bar]	P	Codice / Code Bestell Nr. / Code Código / Código	P _{max} [bar]	OIL [lt]		Kg
						V1	B5	
EF 10 SAE A 2-4 F D. 25 CH 8	110	13	114	4702.014.010	300	0.3	0.15	20
EF 16 SAE A 2-4 F D. 25 CH 8	160	17	114	4702.014.011				
EF 20 SAE A 2-4 F D. 25 CH 8	220	23	114	4702.014.012				
EF 25 SAE A 2-4 F D. 25 CH 8	260	17	114	4702.014.013				
EF 35 SAE A 2-4 F D. 25 CH 8	360	17	114	4702.014.014				
EF 45 SAE A 2-4 F D. 25 CH 8	470	23	114	4702.014.015				
EF 55 SAE A 2-4 F D. 25 CH 8	600	27	114	4702.014.016				

EF								
	Cfs _{min} [Nm]	Pa _{min} [bar]	P	Codice / Code Bestell Nr. / Code Código / Código	P _{max} [bar]	OIL [lt]		Kg
						V1	B5	
EF 10 SAE A 2-4 F D. 25.4 CH 6.35	110	13	114	A richiesta On request Auf Anfrage Sur demande Bajo demanda Sob consulta	300	0.3	0.15	20
EF 16 SAE A 2-4 F D. 25.4 CH 6.35	160	17	114					
EF 20 SAE A 2-4 F D. 25.4 CH 6.35	220	23	114					
EF 25 SAE A 2-4 F D. 25.4 CH 6.35	260	17	114					
EF 35 SAE A 2-4 F D. 25.4 CH 6.35	360	17	114					
EF 45 SAE A 2-4 F D. 25.4 CH 6.35	470	23	114					
EF 55 SAE A 2-4 F D. 25.4 CH 6.35	600	27	114					

EF								
	Cfs _{min} [Nm]	Pa _{min} [bar]	P	Codice / Code Bestell Nr. / Code Código / Código	P _{max} [bar]	OIL [lt]		Kg
						V1	B5	
EF 10 SAE A 2-4 F D. 31.75 CH 7.96	110	13	114	A richiesta On request Auf Anfrage Sur demande Bajo demanda Sob consulta	300	0.3	0.15	20
EF 16 SAE A 2-4 F D. 31.75 CH 7.96	160	17	114					
EF 20 SAE A 2-4 F D. 31.75 CH 7.96	220	23	114					
EF 25 SAE A 2-4 F D. 31.75 CH 7.96	260	17	114					
EF 35 SAE A 2-4 F D. 31.75 CH 7.96	360	17	114					
EF 45 SAE A 2-4 F D. 31.75 CH 7.96	470	23	114					
EF 55 SAE A 2-4 F D. 31.75 CH 7.96	600	27	114					

EF								
	Cfs _{min} [Nm]	Pa _{min} [bar]	P	Codice / Code Bestell Nr. / Code Código / Código	P _{max} [bar]	OIL [lt]		Kg
						V1	B5	
EF 10 SAE A 2-4 F D. 32 CH 10	110	13	114	4702.014.040	300	0.3	0.15	20
EF 16 SAE A 2-4 F D. 32 CH 10	160	17	114	4702.014.041				
EF 20 SAE A 2-4 F D. 32 CH 10	220	23	114	4702.014.042				
EF 25 SAE A 2-4 F D. 32 CH 10	260	17	114	4702.014.043				
EF 35 SAE A 2-4 F D. 32 CH 10	360	17	114	4702.014.044				
EF 45 SAE A 2-4 F D. 32 CH 10	470	23	114	4702.014.045				
EF 55 SAE A 2-4 F D. 32 CH 10	600	27	114	4702.014.046				

		A		B		C		D	
		Z	Z	Z+13.5	Z+15	Z	Z+31	Z	Z+31
PG 100		1-2-3-4	—	—	—	—	—	—	—
PG 160		1-2-3-4	—	—	—	—	—	—	—
PG 250		1-2-3-4	—	1	—	—	—	—	—
PG 500		1-2-3-4	—	1	—	—	—	—	—
PG 700		2-3-4	1	2	—	—	—	—	—
PG 1000		2-3-4	1	2	—	—	—	—	—
PG 1600		2-3-4	1	2	—	—	—	—	—
PG 1800		3-4	2	3	—	—	—	—	—
PG 2500		3-4	2	3	1	—	—	—	—
PG 3000		3-4	2	3	—	—	—	2	—
PG 3500		3-4	2	3	—	—	—	2	—
PG 5000		3-4	2	3	—	—	1	2	—
PG 6500		4	3	4	2	—	—	—	—
PG 9000		4	3	4	2	—	—	—	—
PG 12000		4-5	3	4	2	—	—	3	—
PG 16000		4-5	3	4	—	—	2	3	—
PG 21000		4-5	3	4	—	—	2	3	—
PG 21000 H		5	4	5	3	—	—	—	—
PG 26000		5	4	5	3	—	—	—	—
PG 31000		5	4	5	3	—	—	—	—
PG 31000 H		5	4	5	3	—	—	4	—
PG 40000		5	4	5	3	—	—	4	—
PG 45000		5	4	5	—	—	3	4	—
PG 53000		5	4	5	—	—	3	4	—
PG 61000		—	—	5	4	—	—	—	—

		A		B		C		D	
		Z	Z	Z+16	Z	Z	Z	Z	Z
PGA 100		2-3-4	—	—	—	—	—	—	—
PGA 160		2-3-4	—	—	—	—	—	—	—
PGA 250		2-3-4	—	2-3-4	—	—	—	—	—
PGA 500		2-3-4	—	2-3-4	—	—	—	—	—
PGA 700		2-3-4	—	2-3-4	—	—	—	—	—
PGA 1000		2-3-4	—	2-3-4	—	—	—	—	—
PGA 1600		2-3-4	—	2-3-4	—	—	—	—	—
PGA 1800		3-4	2	3-4	—	—	—	—	—
PGA 2500		3-4	2	3-4	—	—	—	—	—
PGA 3000		3-4	—	3-4	—	—	—	—	—
PGA 3500		4	2-3	4	—	—	—	—	—
PGA 5000		4	—	2-3-4	—	—	—	—	—
PGA 6500		4	—	3-4	—	—	—	—	—
PGA 9000		4	—	3-4	—	—	—	—	—
PGA 12000		5	3-4	5	—	—	—	—	—
PGA 16000		5	3-4	5	—	—	—	—	—
PGA 21000		5	3-4	5	—	—	—	—	—
PGA 21000 H		5	3-4	5	—	—	—	—	—
PGA 26000		5	4	5	—	—	—	—	—
PGA 31000		5	4	5	—	—	—	—	—
PGA 31000 H		—	4-5	—	—	—	—	—	—
PGA 40000		—	4-5	—	—	—	—	—	—
PGA 45000		—	5	—	—	—	—	—	—
PGA 53000		—	5	—	—	—	—	—	—
PGA 61000		—	5	—	—	—	—	—	—

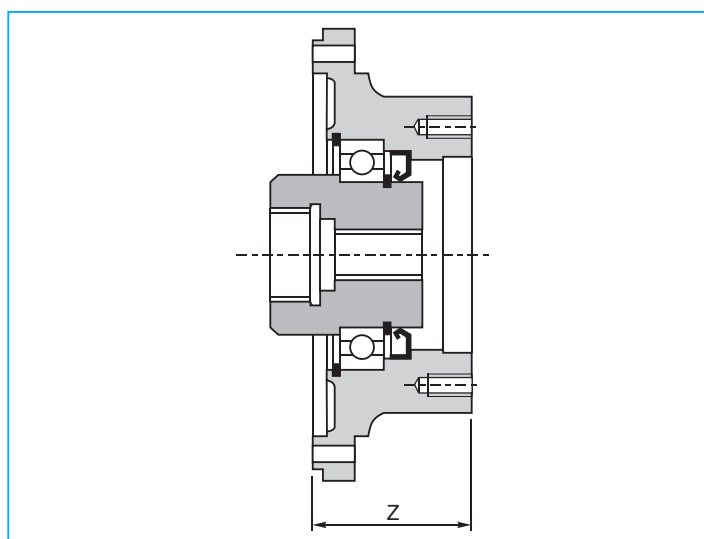

COMER INDUSTRIES (AXIAL PUMP)

Motore tipo / Motor type Motortyp / Moteur type Tipos de motor / Tipos de motor	Z	Codice / Code Bestell Nr. / Code Código / Código	A
M2-AMVCS 34-40-50-55/32 DP TH13	52	4702.013.001	
M2-AMVCS 34-40-50-55/32 DP TH15	52	4702.013.003	
AMF 24-34	81	4702.013.070	
AMF 55	81	4702.013.060	

COMER INDUSTRIES (GEOLINK)

Motore tipo / Motor type Motortyp / Moteur type Tipos de motor / Tipos de motor	Z	Codice / Code Bestell Nr. / Code Código / Código	A
GHL/GFS/GFS Ø 25 CH8	61.5	4702.012.012	
GHL/GFS/GFS Ø 25.4 CH6.35	61.5	4702.012.014	
GHL/GFS/GFS SAE 1"6B	61.5	4702.013.013	
GHL/GFS/GFS 25x22 DIN 5482 TH14	61.5	4702.013.011	
GLS Ø 32 CH10	77.5	4702.012.019	
GLC	38	4702.013.006	
GWS/GWP/GWR - ED	61	4708.502.700	
GWS/GWP/GWR - EDF	61	4708.505.700	

SAUER - DANFOSS

Motore tipo / Motor type Motortyp / Moteur type Tipos de motor / Tipos de motor	Z	Codice / Code Bestell Nr. / Code Código / Código	A
OMM Ø CH5	70.5	4702.012.035	
OMP - OMR Ø 25	61.5	4702.012.012	
OMP - OMR Ø 25.4	61.5	4702.012.014	
OMP - OMR SAE 1"6B	61.5	4702.013.013	
OMS Ø 32	77.5	4702.012.019	
OMS 12/24 DP TH14	77.5	4702.013.039	
OMSS	38	4702.013.006	
OMT Ø 40	134	4702.012.031	
OMTS	78	4702.013.032	

N.B. I numeri 1-2-3-4-5 indicano il numero di stadi dei riduttori.
 N.B.: Numbers 1-2-3-4-5 refer to the number of stages of the planetary gear unit.
 Die Ziffern 1-2-3-4-5 geben die Anzahl der Getriebestufen an.
 N.B.: Les numéros 1-2-3-4-5 indiquent le nombre d'étages des réducteurs.
 Nota: los números 1-2-3-4-5 indican el número de etapas de los reductores.
 OBS.: os números 1-2-3-4-5 indicam o número de estágios do redutor.

Le dimensioni Z riportate vanno verificate con le tabelle di questa pagina.
 Z dimensions have to be verified in the tables of this page.
 Das Mass Z wird in den entsprechenden Tabellen auf dieser Seite festgestellt.
 Les dimensions de Z sont à vérifier dans le tableaux de cette page.
 Las dimensiones Z indicadas tienen que verificarse con las tablas de esta página.
 As dimensões Z indicadas devem ser verificadas com as tabelas desta página.



PREDISPOSIZIONI PER
MOTORI IDRAULICI



HYDRAULIC MOTOR
COUPLINGS



ANBAUVORRICHTUNG FUER
HYDRAULIKMOTORE



ADAPTATIONS POUR
MOTEURS HYDRAULIQUE



ACOPLAMIENTOS PARA
MOTORES HIDRÁULICOS



PREDISPOSIÇÕES PARA
MOTORES HIDRÁULICOS

DINAMIC OIL			
Motore tipo / Motor type Motortyp / Moteur type Tipos de motor / Tipos de motor	Z	Codice / Code Bestell Nr. / Code Código / Código	
AH100/BH150/BH175/BH200 28x34 UNI 8953	55.5	4702.013.024	A
CH250/DH300/DH 35032x38 UNI 8953	138	4702.053.003	B
PH250/PH300 32x38 UNI 8953	130	4702.053.016	
PH800 46x50 UNI 8953	118	4702.053.020	C
PH800/PH1250/MH1000 46x50 UNI 8953	148	4702.073.001	D
PH800/PH1250/MH1000 46x50 UNI 8953	148	4702.083.001	

EATON (CHAR-LYNN)			
Motore tipo / Motor type Motortyp / Moteur type Tipos de motor / Tipos de motor	Z	Codice / Code Bestell Nr. / Code Código / Código	
A-H-S Ø 25	61.5	4702.012.012	A
A-H-S Ø 25.4	61.5	4702.012.014	
A-H-S SAE 1"6B	61.5	4702.013.013	
SERIE 2000			
BEARINGLESS	52	4702.013.033	
Ø 32 CH10	77	4702.012.019	
Ø 31.75 CH7.96	61.5	4702.012.017	
12/24 DP TH14	77.5	4702.013.038	
SERIE 4000			
BEARINGLESS	78	4702.013.045	
Ø 40 CH12	78	4702.012.027	
Ø 31.75 CH7.96	78	4702.012.020	
12/24 DP TH17	78	4702.013.016	
SERIE 6000			
Ø 40 CH12	78	4702.012.027	
12/24 DP TH14	77.5	4702.013.038	

EATON			
Motore tipo / Motor type Motortyp / Moteur type Tipos de motor / Tipos de motor	Z	Codice / Code Bestell Nr. / Code Código / Código	
MF-MV25 16/32 DP TH13	52	4702.013.001	A
MF-MV25 16/32 DP TH15	52	4702.013.003	
MF-MV (33/39/46) 16/32 DP TH21	78	4702.013.017	
MF-MV54 16/32 DP TH23	78	4702.013.018	
MF-MV (33/39/46/54) 12/24 DP TH14	78	4702.013.015	
MF-MV25 Ø 22.22 CH6.25	52	4702.012.001	

HAGGLUNDS-ABEX DENISON			
Motore tipo / Motor type Motortyp / Moteur type Tipos de motor / Tipos de motor	Z	Codice / Code Bestell Nr. / Code Código / Código	
M3D/M1D/M4E/12/24 DP TH14	78	4702.013.015	A
M3B/M3B1/TM3B 16/32 DP TH9	61.5	4702.013.010	
M1C/M4C/M4SC 16/32 DP TH13	52	4702.013.001	
M4C/M4SC Ø 22.22 CH4/75	67	4702.012.003	

REXROTH BOSCH GROUP (HYDROMATIK)			
Motore tipo / Motor type Motortyp / Moteur type Tipos de motor / Tipos de motor	Z	Codice / Code Bestell Nr. / Code Código / Código	
A2FM (10/12/16) W25x1.25 DIN 5480 TH18	61.5	4702.013.009	A
A2FM (23/28/32) W25x1.25 DIN 5480 TH18	81	4702.013.062	
A2FM (23/28/32) W30x2 DIN 5480 TH14	81	4702.013.063	
A2FM (45/56) W30x2 DIN 5480 TH14	78	4702.013.019	
A2FM 45W 32x2 DIN 5480 TH14	78	4702.013.020	
A2FM (56/83) W35x2 DIN 5480 TH16	78	4702.013.021	
A2FM 80 W35x2 DIN 5480 TH16	81.5	4702.013.071	
A2FM (80/90) W40x2 DIN 5480 TH18	81.5	4702.013.064	
A2FM 107 W40x2 DIN 5480 TH18	88.5	4702.013.065	
A2FM 107 W40x2 DIN 5480 TH18	112	4702.053.007	
A2FM (107/125) W45x2 DIN 5480 TH21	112	4702.053.006	B
A2FM 160 W45x2 DIN 5480 TH21	112	4702.053.009	
A2FM (160/180) W50x2 DIN 5480 TH24	112	4702.053.008	
A6VM55 W35x2 DIN 5480 TH16	78	4702.013.021	A
A6VM55 W30x2 DIN 5480 TH14	78	4702.013.019	
A6VM80 W35x2 DIN 5480 TH16	81.5	4702.013.071	
A6VM80 W40x2 DIN 5480 TH18	81.5	4702.013.064	
A6VM107 W40x2 DIN 5480 TH18	88.5	4702.013.065	B
A6VM107 W40x2 DIN 5480 TH18	112	4702.053.007	
A6VM107 W45x2 DIN 5480 TH21	112	4702.053.006	
A6VM160 W45x2 DIN 5480 TH21	112	4702.053.009	

INTERMOT			
Motore tipo / Motor type Motortyp / Moteur type Tipos de motor / Tipos de motor	Z	Codice / Code Bestell Nr. / Code Código / Código	
NHM 100/150 26x32 UNI 8953	72.5	4702.013.052	A
NHM 200/250/300 32x38 UNI 8953	130	4702.053.016	B
NHM 400/450/500/600 36x42 UNI 8953	143	4702.053.017	
NHM 700/800/900/1000/1100 46x50 UNI 8953	118	4702.053.020	C
NHM 700/800/900/1000/1100 46x50 UNI 8953	148	4702.073.002	D
NHM 700/800/900/1000/1100 46x50 UNI 8953	148	4702.083.002	
NHM 1400/1600/1800/2000 62x72 UNI 8953	179	4702.053.021	B
NHM 1400/1600/1800/2000 62x72 UNI 8953	148	4702.073.003	C
NHM 1400/1600/1800/2000 62x72 UNI 8953	148	4702.083.003	D

LINDE			
Motore tipo / Motor type Motortyp / Moteur type Tipos de motor / Tipos de motor	Z	Codice / Code Bestell Nr. / Code Código / Código	
MF43M 16/32 DP TH15	52	4702.013.003	A
MF63M 12/24 DP TH14	78	4702.013.015	
BMF35 25x22 DIN 5482 TH14	81	4702.013.070	
BMF50 30x27 DIN 5482 TH16	81	4702.013.060	
BMF75 35x31 DIN 5482 TH18	98	4702.013.061	
BMF 105 40x36 DIN 5482 TH20	90.5	4702.013.068	

Le dimensioni Z riportate vanno verificate con la tabella a pag. D-15.
Z dimensions have to be verified in the table on page D-15.
Das Mass Z wird in der entsprechenden Tabelle auf der Seite D-15 festgestellt.
Les dimensions de Z sont à vérifier dans le tableau à page D-15.
Las dimensiones Z indicadas tienen que verificarse con la tabla de la Pág. D-15.
As dimensões Z indicadas devem ser verificadas com a tabela da pag. D-15.

SAUER - DANFOSS (SAUER-SUNSTRAND)			
Motore tipo / Motor type Motortyp / Moteur type Tipos de motor / Tipos de motor	Z	Codice / Code Bestell Nr. / Code Código / Código	
SERIE 90 (FLANGE SAE)			
90M032/042 16/32 DP TH13	52	4702.013.001	A
90M032/042 16/32 DP TH15	52	4702.013.003	
90M055 16/32 DP TH21	78	4702.013.017	
90M075/100 16/32 DP TH23	78	4702.013.018	
90M130 16/32 DP TH27	112	4702.053.012	
SERIE 40 (FLANGE SAE)			
MMF025 16/32 DP TH13	52	4702.013.001	A
MMF035/MMV035 16/32 DP TH15	52	4702.013.003	
MMF046/MMV046 16/32 DP TH13	52	4702.013.001	
MMF046/MMV046 16/32 DP TH15	52	4702.013.003	
SERIE 51 (FLANGE SAE)			
51V060 (C6) 13/32 DP TH21	78	4702.013.017	A
51V060 (S1) 12/24 DP TH14	78	4702.013.015	
51V080 (C7) 16/32 DP TH23	78	4702.013.018	
51V080 (S1) 12/24 DP TH14	78	4702.013.015	
51V110 (C8) 16/32 DP TH27	112	4702.053.012	
51V110 (F1) 8/16 DP TH13	112	4702.053.005	B
OMF/SMF18 16/32 DP TH13			
OMF/SMF18 16/32 DP TH13	52	4702.013.001	A
OMV/SMV 16/32 DP TH13	67	4702.013.067	
SMF2 (033/052/070) 16/32 DP TH21	78	4702.013.017	
SMF3 (049/066) 16/32 DP TH21	78	4702.013.017	

SAI			
Motore tipo / Motor type Motortyp / Moteur type Tipos de motor / Tipos de motor	Z	Codice / Code Bestell Nr. / Code Código / Código	
SAI M05 28x34 UNI 8953	73.5	4702.013.041	A
SAI M05 35x2 DIN 5480 TH16	73.5	4702.013.044	
SAI M1 28x34 UNI 8953	55.5	4702.013.022	
SAI M1 35x2 DIN 5480 TH16	55.5	4702.013.040	
SAI M2 36x40 UNI 8953	78.5	4702.013.066	
SAI M2/M3 36x40 UNI 8953	137	4702.053.010	B
SAI M4 56x65 UNI 8953	96	4702.053.025	

SAE J744C			
Motore tipo / Motor type Motortyp / Moteur type Tipos de motor / Tipos de motor	Z	Codice / Code Bestell Nr. / Code Código / Código	
SAE A 16/32 DP TH9	61.5	4702.013.010	A
SAE B 16/32 DP TH13	52	4702.013.001	
SAE BB 16/32 DP TH15	52	4702.013.003	
SAE C 12/24 DP TH14	78	4702.013.015	
SAE CC 12/24 DP TH17	78	4702.013.016	
SAE D 8/16 DP TH13	112	4702.053.005	B

STAFFA			
Motore tipo / Motor type Motortyp / Moteur type Tipos de motor / Tipos de motor	Z	Codice / Code Bestell Nr. / Code Código / Código	
HMC 030	142	4702.052.001	B

SAMHYDRAULIC			
Motore tipo / Motor type Motortyp / Moteur type Tipos de motor / Tipos de motor	Z	Codice / Code Bestell Nr. / Code Código / Código	
AG/AR Ø 25 CH8	61.5	4702.012.012	A
AG/AR Ø 25.4 CH6.35	61.5	4702.012.014	
AG/AR Ø 25x22 DIN 5482 TH14	61.5	4702.013.011	
AG/AR SAE 1"6B	61.5	4702.013.013	
AGS/ARS Ø 25 CH8	61.5	4702.012.026	
AGS/ARS Ø 32 CH10	77.5	4702.012.019	
AGS/ARS SAE 1"6B	61.5	4702.013.012	
HPR Ø 32 CH10	77.5	4702.012.019	
HPRC	38	4702.013.006	

PARKER (TRW TORQMOTOR)			
Motore tipo / Motor type Motortyp / Moteur type Tipos de motor / Tipos de motor	Z	Codice / Code Bestell Nr. / Code Código / Código	
MF/MAC/MAF/MAB Ø 25 CH8	61.5	4702.012.012	A
MF/MAC/MAF/MAB Ø 25.4 CH6.35	61.5	4702.013.014	
MF/MAC/MAF/MAB SAE 1"6B	61.5	4702.013.013	
MAB/MAE Ø 31.75 CH7.96	77.5	4702.012.016	
ME 12/24 DP TH14	77.5	4702.013.047	

EATON (VICKERS)			
Motore tipo / Motor type Motortyp / Moteur type Tipos de motor / Tipos de motor	Z	Codice / Code Bestell Nr. / Code Código / Código	
25M 16/32 DP TH13	52	4702.013.001	A
35M-45M 12/24 DP TH14	78	4702.013.015	
MVE-MFE19 16/32 DP TH15	52	4702.013.003	
35M-45M Ø 31.75	78	4702.012.020	

PARKER (VOLVO)			
Motore tipo / Motor type Motortyp / Moteur type Tipos de motor / Tipos de motor	Z	Codice / Code Bestell Nr. / Code Código / Código	
F11/10 (M-C-K) Ø 20 CH6	81	4702.012.065	A
F11/10 (C-T) W20x1.25 DIN 5480 TH14	49	4702.013.046	
F11/39/58 (M-C-D) W30x2 DIN 5480 TH14	81.5	4702.013.030	
F11/78 (M-C-D) W40x2 DIN 5480 TH18	88.5	4702.013.065	
F11/110 (M-C-D) W40x2 DIN 5480 TH18	88.5	4702.013.034	
F11/110 (M-C-D) W40x2 DIN 5480 TH18	112	4702.053.018	B
F12/30 (M-F-Z) W25x1.25 DIN 5480 TH18	81	4702.013.062	A
F12/40 (M-F-D) W32x2 DIN 5480 TH14	78	4702.013.020	
F12/80 (M-I-D) W40x2 DIN 5480 TH18	81.5	4702.013.064	
V11 (60/80) (M-S-S) 12/24 DP TH14	78	4702.013.015	
V12/60 (M-I-C) W30x2 DIN 5480 TH14	78	4702.013.019	
V12/60 (M-I-D) W35x2 DIN 5480 TH16	78	4702.013.021	
V12-110 (U-S) S8/16 DP TH13	112	4702.053.005	
V12/110 (M-I-D) W45x2 DIN 5480 TH21	112	4702.053.006	

WHITE			
Motore tipo / Motor type Motortyp / Moteur type Tipos de motor / Tipos de motor	Z	Codice / Code Bestell Nr. / Code Código / Código	
HS-RS Ø 25	61.5	4702.012.012	A
HS-RS Ø 1"6B	61.5	4702.013.013	
RE Ø 32	77.5	4702.012.019	
RE Ø 31.75	77.5	4702.012.016	

Le dimensioni Z riportate vanno verificate con la tabella a pag. D-15.
Z dimensions have to be verified in the table on page D-15.
Das Mass Z wird in der entsprechenden Tabelle auf der Seite D-15 festgestellt.
Les dimensions de Z sont à vérifier dans le tableau à page D-15.
Las dimensiones Z indicadas tienen que verificarse con la tabla de la Pág. D-15.
As dimensões Z indicadas devem ser verificadas com a tabela da pag. D-15.

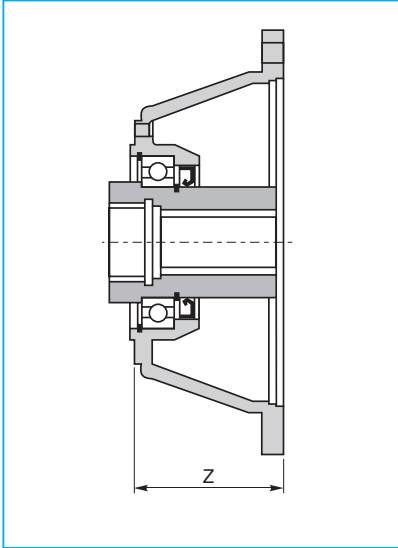

UNEL/IEC B5			
	Z	Codice / Code Bestell Nr. / Code Código / Código.	
H63	36	4702.011.005	A
H71	36	4702.011.006	
H80	56	4702.011.001	
H90	56	4702.011.002	
H100/112	66	4702.011.003	
H132	100	4702.011.004	B
H160	139	4702.011.047	
H180	139	4702.011.048	
H160	118	4702.051.001	
H180	118	4702.051.002	
H200	148	4702.051.015	C
H225	139	4702.051.016	
H250	148.5	4702.051.024	
H280	148.5	4702.051.025	
H160	150	4702.071.001	
H180	150	4702.071.002	D
H200	150	4702.071.003	
H225	139	4702.071.004	
H250	139	4702.071.005	
H280	139	4702.071.006	
H160	150	4702.081.001	
H180	150	4702.081.002	
H200	150	4702.081.003	
H225	139	4702.081.004	
H250	139	4702.081.005	
H280	139	4702.081.006	

NEMA C			
	Z	Codice / Code Bestell Nr. / Code Código / Código.	
143TC-145TC	80	4702.011.008	A
182TC-184TC			
182TC-184TC	88.5	4702.011.009	
213TC-215TC			
213TC-215TC	88.5	4702.011.010	
286TC	139	4702.051.006	B
326TC	149	4702.051.007	
365TS	149	4702.051.010	

Le dimensioni Z riportate vanno verificate con le tabelle di questa pagina.
Z dimensions have to be verified in the tables of this page.
Das Mass Z wird in den entsprechenden Tabellen auf dieser Seite festgestellt.
Les dimensions de Z sont à vérifier dans les tableaux de cette page.
Las dimensiones Z indicadas tienen que verificarse con las tablas de esta página.
As dimensões Z indicadas devem ser verificadas com as tabelas desta página.

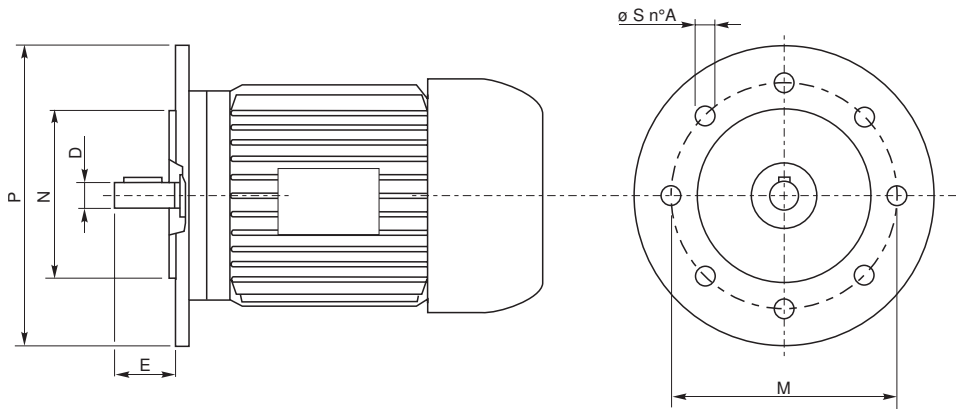

	N° poli - Number of poles - Anzahl Pole Numero poles - N° de polos - N° de pólos									D	E	P	M	N	S	A
	2		4		6											
	[kW]	[kW]	[kW]	[kW]	[kW]	[kW]										
63	0.18		0.25	0.12		0.18	0.06	0.09	11	23	140	115	95	9.5	4	
71	0.37		0.55	0.25		0.37	0.18	0.25	14	30	160	130	110	9.5	4	
80	0.75		1.1	0.55		0.75	0.37	0.55	19	40	200	165	130	11.5	4	
90	1.5		2.2	1.1		1.5	0.75	1.1	24	50	200	165	130	11.5	4	
100/112	3		4	2.2	3	4	1.5	2.2	28	60	250	215	180	14	4	
132	5.5		7.5	5.5		7.5	3	4	38	80	300	265	230	14	4	
160	11	15	18.5	11		15	7.5	11	42	110	350	300	250	18	4	
180	22			18.5		22	15		48	110	350	300	250	18	4	
200	30		37	30			18.5	22	55	110	400	350	300	18	4	
225	45			37		45	30		60 (55-2p)	140	450	400	350	18	8	
250	55			55			37		65 (60-2p)	140	550	500	450	18	8	
280	75		90	75		90	45	55	75 (65-2p)	140	550	500	450	18	8	

ACC.



**PREDISPOSIZIONI PER
RIDUTTORI A VITE
SENZA FINE**



**WORM GEARBOX
ADAPTORS**



**ANSCHLUSS FÜR
SCHNECKENGETRIEBE**

Comer Industries può fornire i riduttori combinati nelle seguenti configurazioni:

- 1) Completi di riduttore a vite senza fine.
- 2) Predisposti per riduttori a vite senza fine.

Inoltre ricordiamo che i riduttori epicicloidali hanno la lubrificazione separata da quella del riduttore a vite senza fine.

Comer Industries can supply the combined reduction units as follows:

- 1) Complete of worm reduction units.
- 2) Preset for worm reduction units.

Furthermore, we would like to remind you that the lubrication of the planetary gear units is separated from the lubrication of the worm reduction units.

Comer Industries kann kombinierte Getriebe wie folgt liefern:

- 1) komplett mit Schneckengetriebe.
- 2) Vorrichtung für Schnecken- getriebe.

Weiterhin weisen wir darauf hin, das die Schmierung der Planetengetriebe getrennt von der des Schneckengetriebes erfolgt.



**ADAPTATION POUR
REDUCTEURS A VIS
SANS FIN**

Les réducteurs combinés peuvent être fournis de la manière suivante:

- 1) Equipés d'un réducteur à vis sans fin.
- 2) Equipés pour recevoir un réducteur à vis sans fin.

En outre, nous vous rappelons que le réducteurs planétaires ont une lubrification séparée de celle du réducteur à vis sans fin.



**ACOPLAMIENTO PARA
REDUCTORES DE TORNILLO
SIN FIN**

Comer Industries puede suministrar las unidades de reducción combinadas del siguiente modo:

- 1) Completos con reductor de tornillo sin fin.
- 2) Predisuestos para reductores de tornillo sin fin.

Además, queremos recordar que los reductores epicicloidales tienen la lubricación separada de aquella del reductor de tornillo sin fin.



**PREDISPOSIÇÕES PARA
REDUTORES DE ROSCA
SEM FIM**

A Comer Industries pode fornecer os reductores combinados nas seguintes configurações:

- 1) Munidos de reductor de rosca sem fim.
- 2) Com predisposição para reductores de rosca sem fim.

Lembramos ainda que a lubrificação dos reductores planetários é separada da lubrificação do reductor de rosca sem fim.

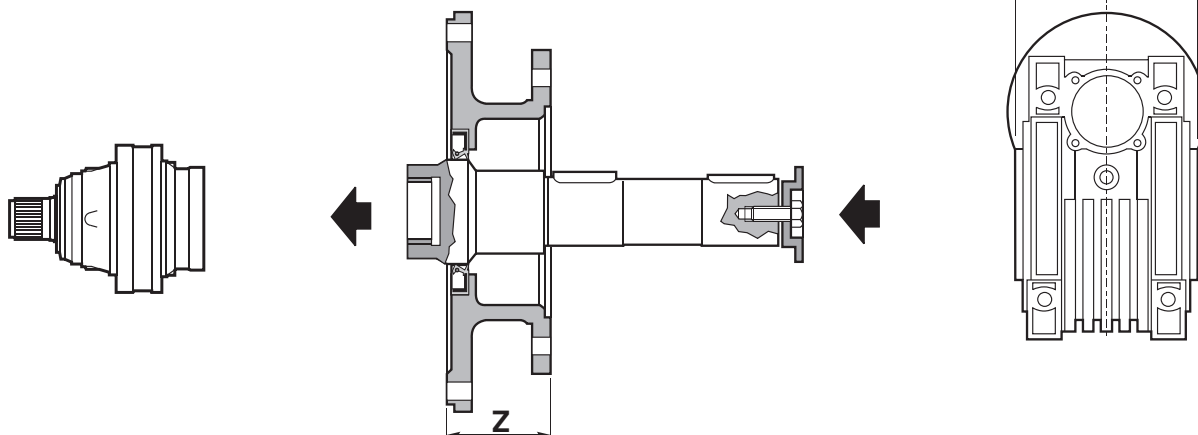

PREDISPOSIZIONI PER RIDUTTORI VITE SENZA FINE WORM GEARBOX ADAPTORS ANSCHLUSS FÜR SCHNECKENGETRIEBE ADAPTATIONS POUR REDUCTEURS A VIS SANS FIN ACOPLAMIENTO PARA REDUCTORES DE TORNILLO SIN FIN PREDISPOSIÇÕES PARA REDUTORES DE ROSCA SEM FIM			
Tipo - Type - Type - Typ - Tipos - Tipos	Z	Codice / Code Bestell Nr. / Code Código / Código	
NMRV 50 / NRV 50	82	4702.017.004	A
NMRV 63 / NRV 63	82	4702.017.005	
NMRV 75 / NRV 75	57	4702.017.006	
NMRV 90 / NRV 90	57	4702.017.007	
NMRV 110 / NRV 110	64	4702.057.002	
NMRV 130 / NRV 130	64	4702.057.001	B

RIDUTTORI VITE SENZA FINE WORM REDUCTION UNITS SCHNECKENGETRIEBE REDUCTEURS A VIS SANS FIN REDUCTORES DE TORNILLO SIN FIN REDUTORES DE ROSCA SEM FIM		
Tipo - Type - Type Typ - Tipos - Tipos	F	P
NMRV 50 / NRV 50	46	46
NMRV 63 / NRV 63	56	56
NMRV 75 / NRV 75	60	60
NMRV 90 / NRV 90	70	70
NMRV 110 / NRV 110	77.5	77.5
NMRV 130 / NRV 130	85	85

	A		B	
	Z	Z	Z	Z+13.5
PG 100	1-2-3-4	—	—	—
PG 160	1-2-3-4	—	—	—
PG 250	1-2-3-4	—	1	1
PG 500	1-2-3-4	—	1	1
PG 700	2-3-4	1	2	2
PG 1000	2-3-4	1	2	2
PG 1600	2-3-4	1	2	2
PG 1800	3-4	2	3	3
PG 2500	3-4	2	3	3
PG 3000	3-4	2	3	3
PG 3500	3-4	2	3	3
PG 5000	3-4	2	3	3
PG 6500	4	3	4	4
PG 9000	4	3	4	4

	A		B	
	Z	Z	Z	Z+13.5
PG 12000	4-5	3	4	4
PG 16000	4-5	3	4	4
PG 21000	4-5	3	4	4
PG 21000 H	5	4	5	5
PG 26000	5	4	5	5
PG 31000	5	4	5	5
PG 31000 H	5	4	5	5
PG 40000	5	4	5	5
PG 45000	5	4	5	5
PG 53000	5	4	5	5
PG 61000	—	5	—	—

N.B. I numeri 1-2-3-4-5 indicano il numero di stadi dei riduttori.
 N.B.: Numbers 1-2-3-4-5 refer to the number of stages of the planetary gear unit.
 Die Ziffern 1-2-3-4-5 geben die Anzahl der Getriebestufen an.
 N.B.: Les numéros 1-2-3-4-5 indiquent le nombre d'étages des réducteurs.
 Nota: los números 1-2-3-4-5 indican el número de etapas de los reductores.
 OBS.: os números 1-2-3-4-5 indicam o número de estágios do reductor.

PREDISPOSIZIONI PER
RIDUTTORI A VITE
SENZA FINE

IT

WORM GEARBOX
ADAPTORS

EN

ANSCHLUSS FÜR
SCHNECKENGETRIEBE

DE

ADAPTATION POUR
REDUCTEURS A VIS
SANS FIN

FR

ACOPLAMIENTO PARA
REDUCTORES DE TORNILLO
SIN FIN

ES

PREDISPOSIÇÕES PARA
REDUTORES DE ROSCA
SEM FIM

PT

NMRV

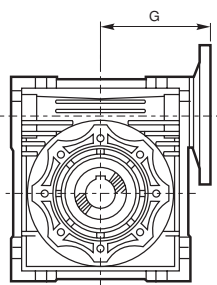

RIDUTTORI VITE SENZA FINE / WORM REDUCTION UNITS SCHNECKENGETRIEBE / REDUCTEURS A VIS SANS FIN REDUCTORES DE TORNILLO SIN FIN / REDUTORES DE ROSCA SEM FIM	
Tipo - Type - Type - Typ - Tipo - Tipo	G
NMRV 50 PAM 63 71 80	80
NMRV 63 PAM 71 80 90	95
NMRV 75 PAM 71 80 90 112	112.5
NMRV 90 PAM 80 90 100 112	129.5
NMRV 110 PAM 80 90 100 112 132	160
NMRV 130 PAM 90 100 112 132	180

Riduttore vite senza fine con predisposizione per motore elettrico (PAM/IEC).

Worm gear reduction unit with input adaptor for electric motor (PAM/IEC).
Schneckengetriebe vorgesehen für Elektromotoranbau (PAM/IEC).

Réducteur à vis sans fin avec prédisposition pour moteur électrique (PAM/IEC).

Reductor de tornillo sin fin con acoplamiento para motor eléctrico (PAM/IEC).

Redutor de rosca sem fim com predisposição para motor elétrico (PAM/IEC).

NRV

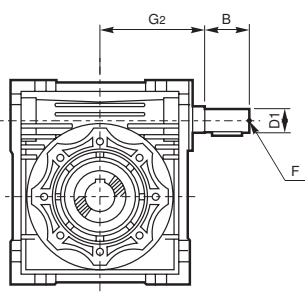

SPORGENZA ALBERO DI ENTRATA / INPUT SHAFT LENGTH ANTRIEBSWELLENÄNGE / ARBRE D'ENTREE MALE SALIENTE EJE DE ENTRADA / SALIÊNCIA DO EIXO DE ENTRADA				
Tipo - Type - Type - Typ - Tipo - Tipo	G2	B	D1 (J6)	F
NRV 50	72	30	14	M6
NRV 63	90	40	19	M6
NRV 75	105	50	24	M8
NRV 90	125	50	24	M8
NRV 110	142	60	28	M10
NRV 130	162	80	30	M10

Riduttore vite senza fine con albero maschio in ingresso.

Worm gear reduction unit with male input shaft.

Schneckengetriebe mit Zapfwelle am Eingang.

Réducteur à vis sans fin avec arbre mâle en entrée.

Reductor de tornillo sin fin con eje macho en entrada.

Redutor de rosca sem fim com eixo macho na entrada.

Per la selezione del riduttore vite senza fine contattare il Servizio Tecnico Commerciale Comer Industries.

To select the worm reduction unit please contact the Comer Industries Technical-Commercial Service Department.

Für die Auswahl des Schneckengetriebes kontaktieren sie bitte dem Kundenservice (Sales) von Comer Industries.

Pour choisir le réducteur à vis sans fin, s'adresser an Service Technico-Commercial Comer Industries.

Para la elección del reductor de tornillo sin fin se aconseja ponerse en contacto con el Servicio Técnico-Comercial de Comer Industries.

Para a seleção do redutor de rosca sem fim, entre em contato com o Serviço Técnico Comercial da Comer Industries.

Posizioni di montaggio

Mounting positions

Einbauposition

Positions de montage

Posiciones de montaje

Posições de montagem

F
M
P
FS

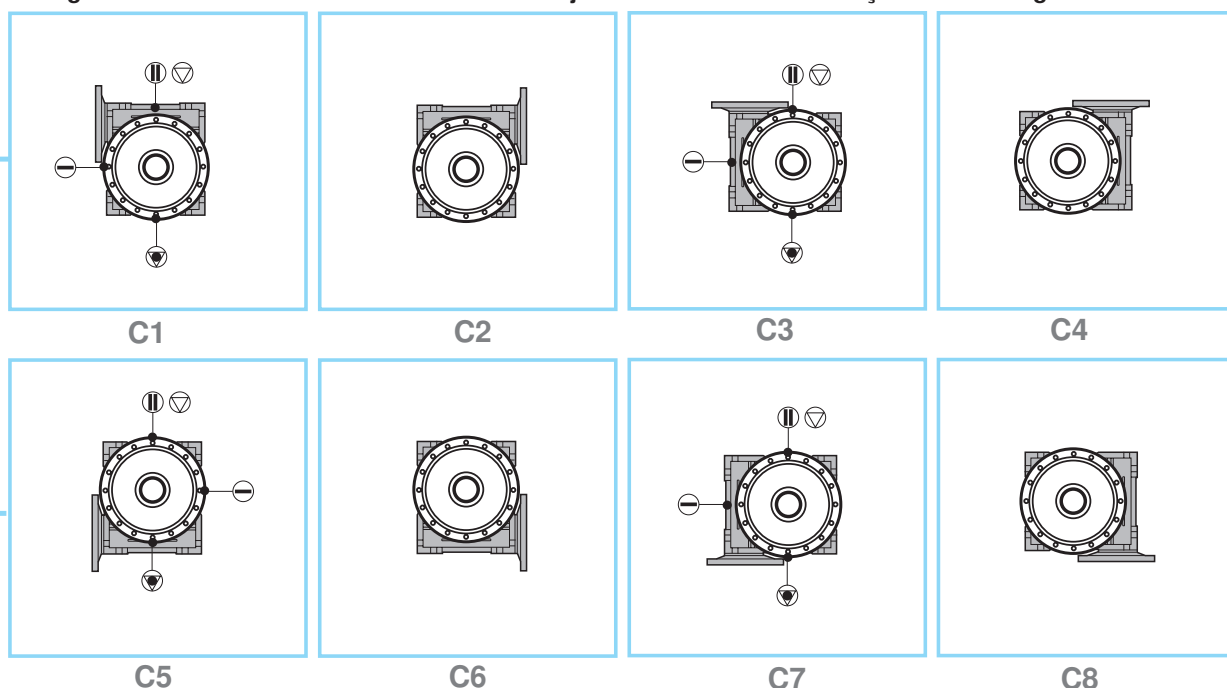

ACC.

IT

PREDISPOSIZIONI PER
RIDUTTORI A VITE
SENZA FINE

EN

WORM GEARBOX ADAPTORS

DE

ANSCHLUSS FÜR
SCHNECKENGETRIEBE

FR

ADAPTATION POUR
REDUCTEURS A VIS
SANS FIN

ES

ACOPLAMIENTO PARA
REDUCTORES DE TORNILLO
SIN FIN

PT

PREDISPOSIÇÕES PARA
REDUTORES DE ROSCA
SEM FIM

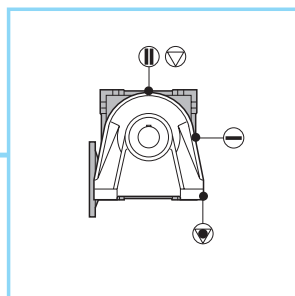

C9

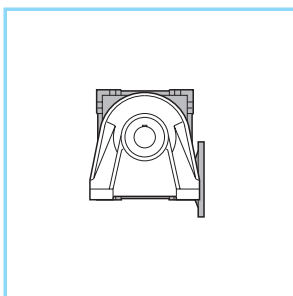

C10

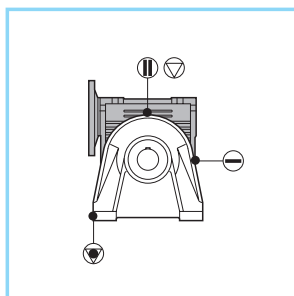

C11

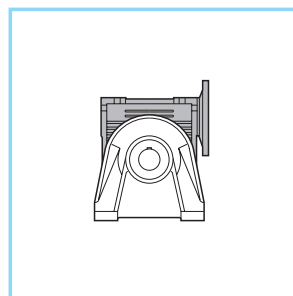

C12

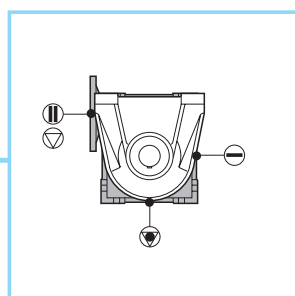

C13

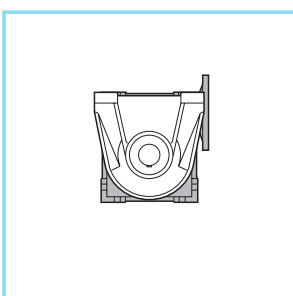

C14

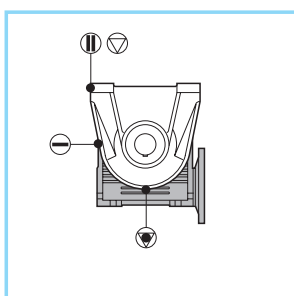

C15

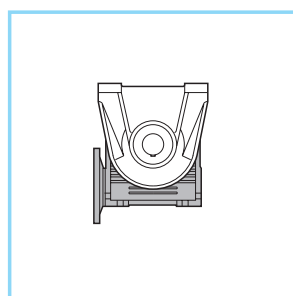

C16

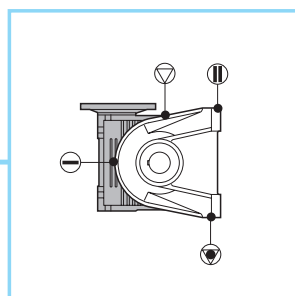

C17

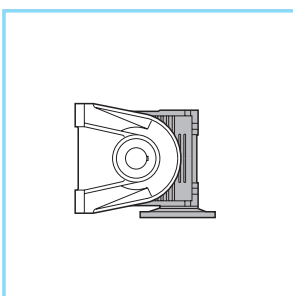

C18

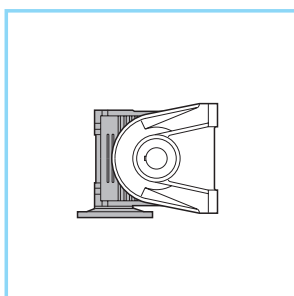

C19

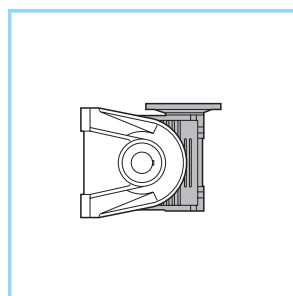

C20

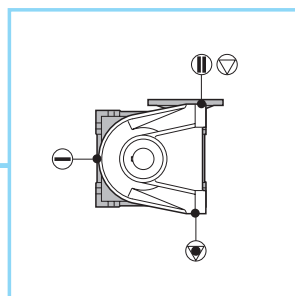

C21

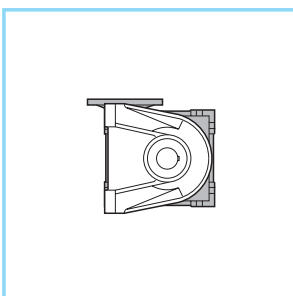

C22

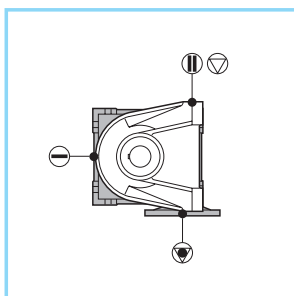

C23

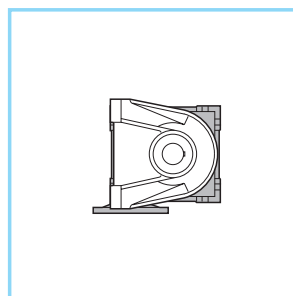

C24

Tappi olio
Oil plugs
Ölstopfen
Bouchons huile
Tapón de aceite
Bujão de óleo



Tappo sfiato
Vent plug
Entlüftungstopfen
Bouchon à évent
Tapón de venteo
Bujão de respiro



Tappo carico
Filling plug
Einfüllstopfen
Bouchon remplissage
Tapón de carga
Bujão de enchimento



Tappo livello
Level plug
Ölstandstopfen
Bouchon jauge
Tapón de nivel
Bujão de nível



Tappo scarico
Drain plug
Ablassstopfen
Bouchon vidange
Tapón de descarga
Bujão de descarga

N.B.

L'orientamento della foratura della flangia di fissaggio è come illustrato nelle schede dei dati dimensionali dei riduttori

N.B.

L'orientation de la flasque de montage est indiquée dans chaque fiche technique réducteur

N.B.

The mounting flange orientation is shown in each planetary gears technical sheets

N.B.

La orientación del perforado de la brida de fijación se ilustra en las fichas de los datos dimensionales de los reductores

N.B.

Die Ausfuehrung der Befestigungs- vorrichtung (Flansch, Bohrung) ist in den Datenblaettern der Getriebe auf den ersichtlich

N.B.

A orientação da furação do flange de fixação é a ilustrada nas fichas de dados técnicos dimensionais dos reductores

PREDISPOSIZIONI PER
RIDUTTORI A VITE
SENZA FINE

IT

WORM GEARBOX ADAPTORS

EN

ANSCHLUSS FÜR
SCHNECKENGETRIEBE

DE

ADAPTATION POUR
REDUCTEURS A VIS
SANS FIN

FR

ACOPAMIENTO PARA
REDUCTORES DE TORNILLO
SIN FIN

ES

PREDISPOSIÇÕES PARA
REDUTORES DE ROSCA
SEM FIM

PT

M-P

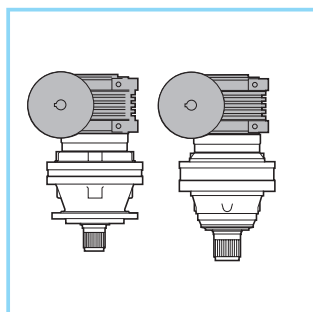

C25

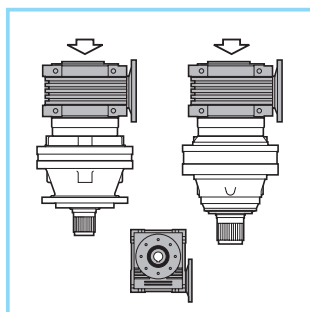

C26

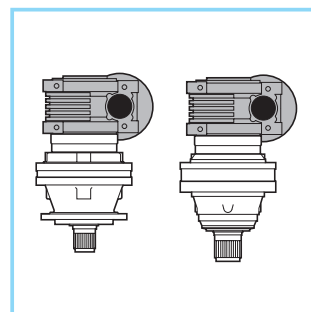

C27

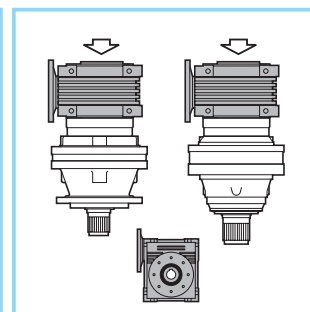

C28

F

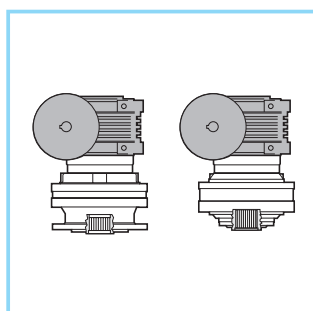

C25

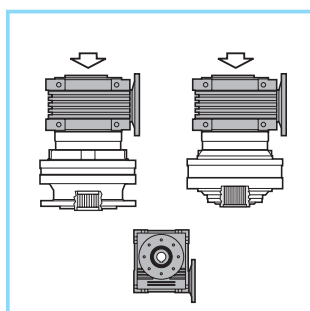

C26

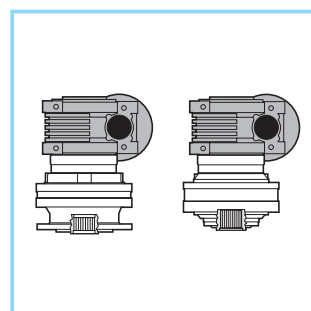

C27

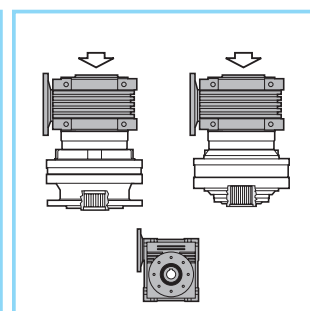

C28

FS

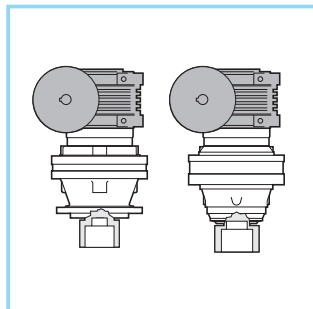

C25

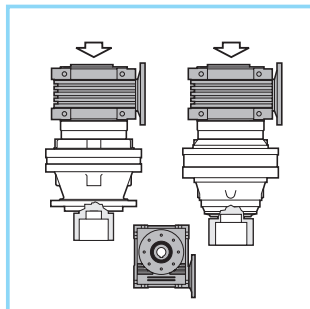

C26

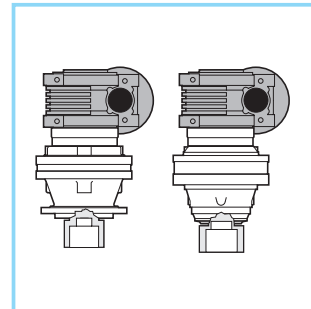

C27

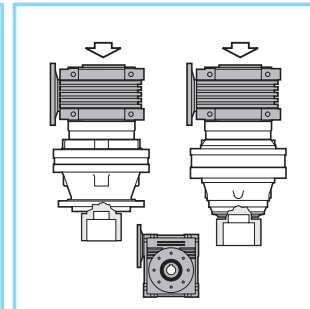

C28

CPC

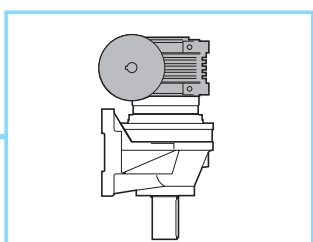

C41

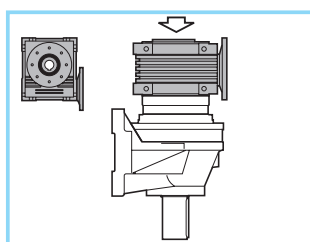

C42

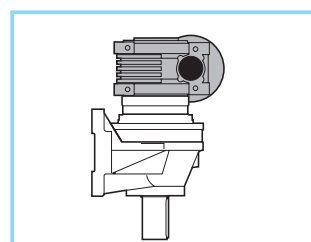

C43

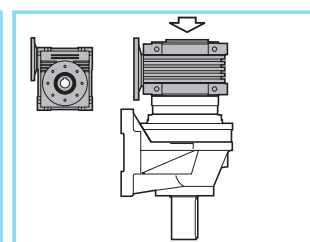

C44

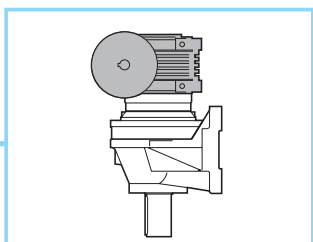

C45

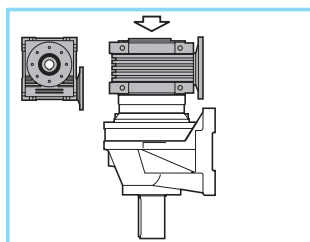

C46

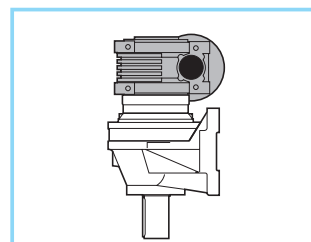

C47

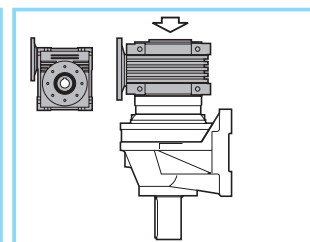

C48

ACC.

IT

PREDISPOSIZIONI PER RIDUTTORI A VITE SENZA FINE

EN

WORM GEARBOX ADAPTORS

DE

ANSCHLUSS FÜR SCHNECKENGETRIEBE

FR

ADAPTATION POUR REDUCTEURS A VIS SANS FIN

ES

ACOPLAMIENTO PARA REDUCTORES DE TORNILLO SIN FIN

PT

PREDISPOSIÇÕES PARA REDUTORES DE ROSCA SEM FIM

M-P

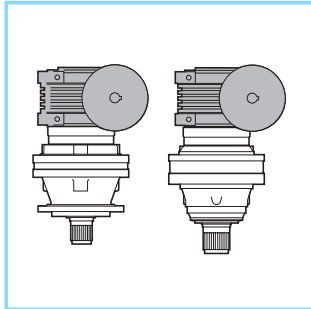

C29

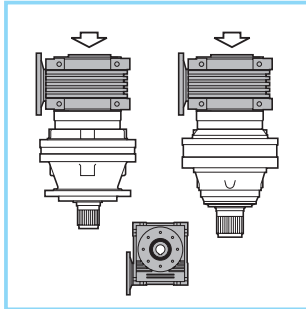

C30

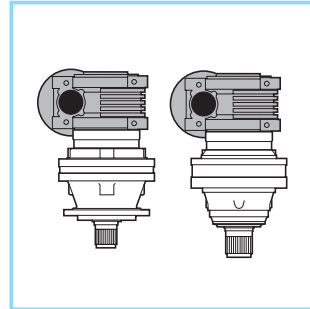

C31

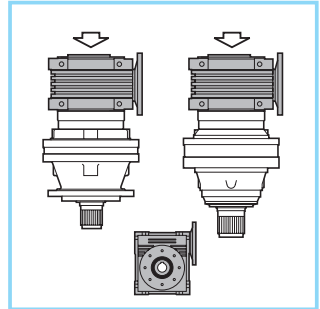

C32

F

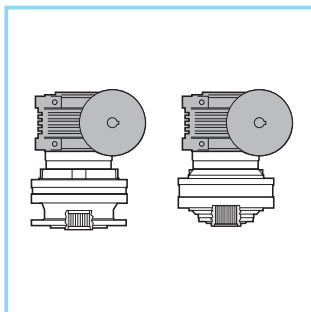

C29

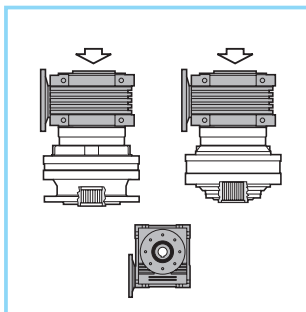

C30

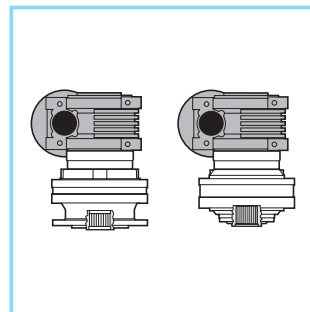

C31

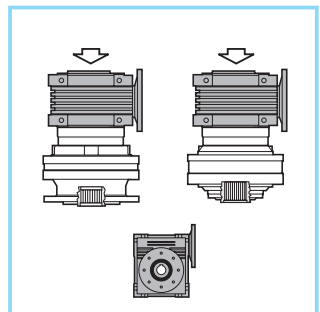

C32

FS

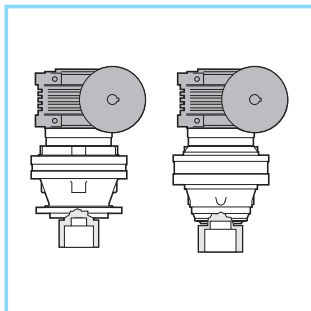

C29

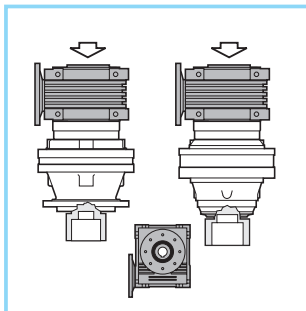

C30

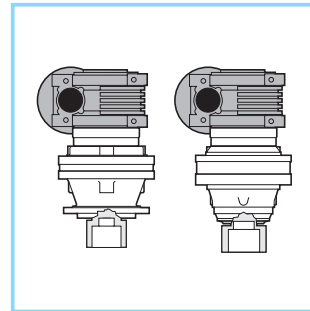

C31

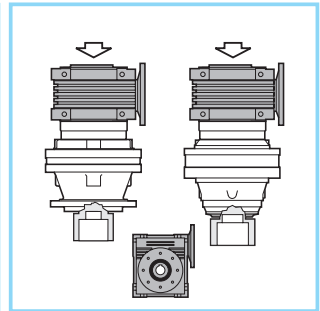

C32

CPC

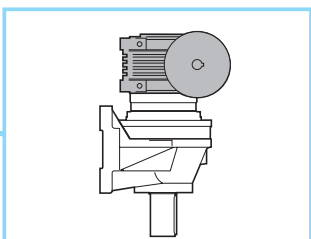

C49

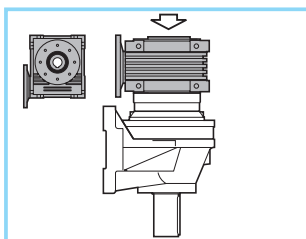

C50

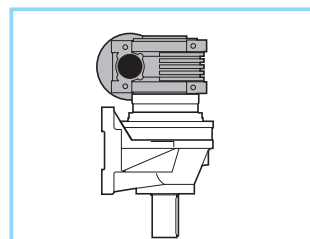

C51

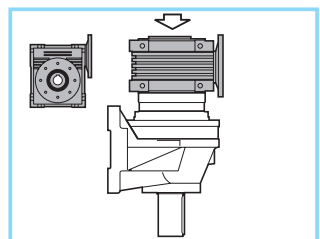

C52

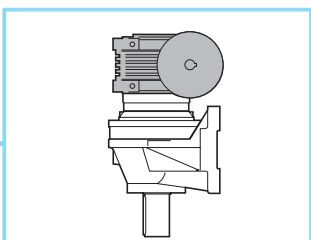

C53

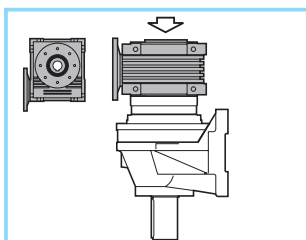

C54

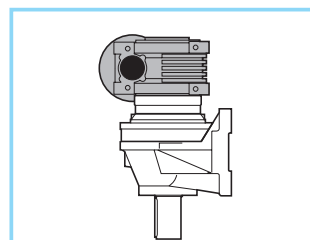

C55

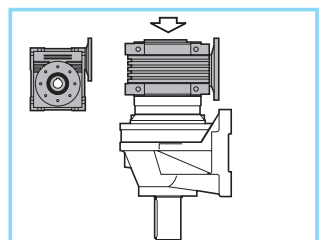

C56

PREDISPOSIZIONI PER
RIDUTTORI A VITE
SENZA FINE

IT

WORM GEARBOX ADAPTORS

EN

ANSCHLUSS FÜR
SCHNECKENGETRIEBE

DE

ADAPTATION POUR
REDUCTEURS A VIS
SANS FIN

FR

ACOPLAMIENTO PARA
REDUCTORES DE TORNILLO
SIN FIN

ES

PREDISPOSIÇÕES PARA
REDUTORES DE ROSCA
SEM FIM

PT

M-P

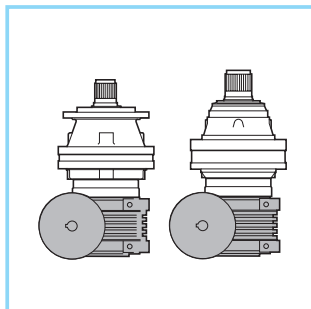

C33

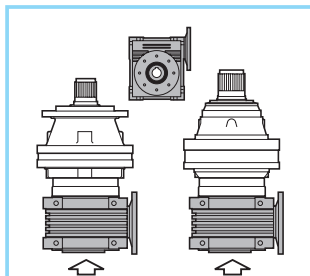

C34

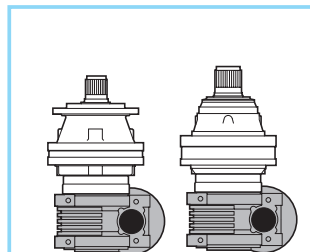

C35

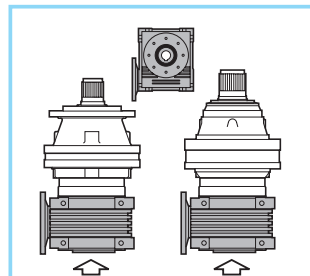

C36

F

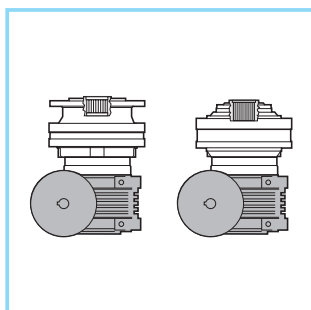

C33

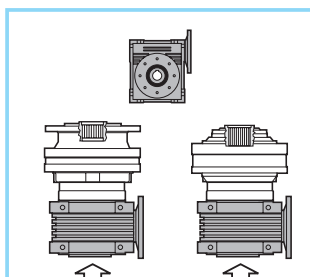

C34

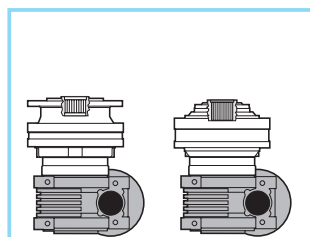

C35

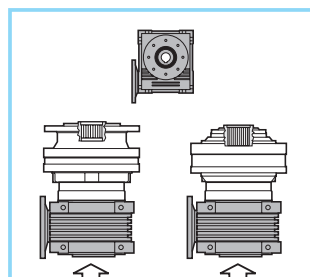

C36

FS

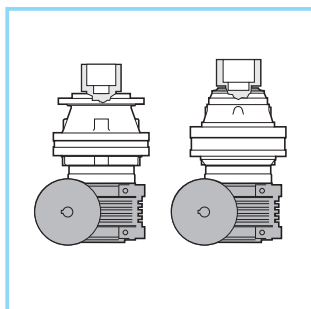

C33

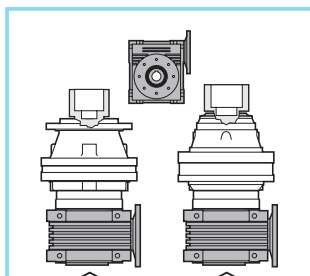

C34

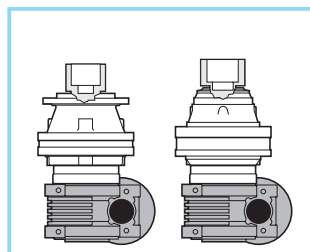

C35

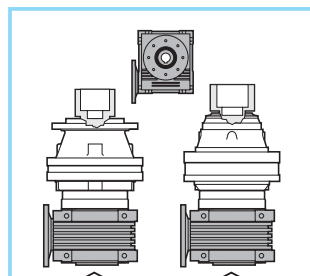

C36

CPC

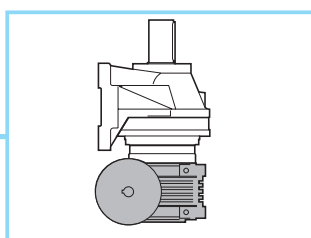

C57

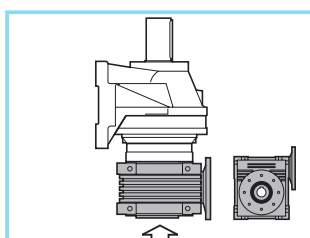

C58

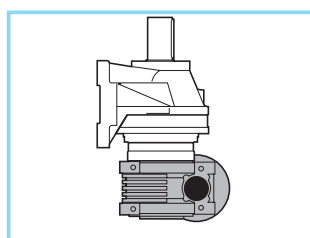

C59

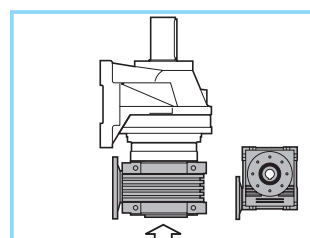

C60

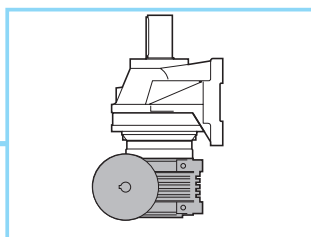

C61

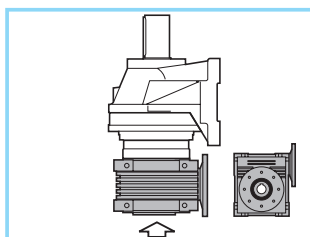

C62

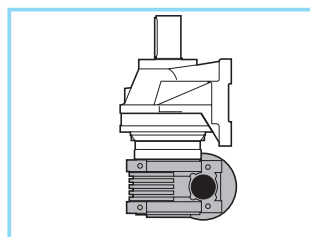

C63

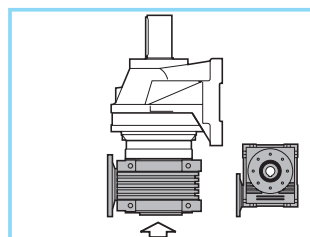

C64

ACC.



IT

PREDISPOSIZIONI PER
RIDUTTORI A VITE
SENZA FINE

EN

WORM GEARBOX ADAPTORS

DE

ANSCHLUSS FÜR
SCHNECKENGETRIEBE

FR

ADAPTATION POUR
REDUCTEURS A VIS
SANS FIN

ES

ACOPLAMIENTO PARA
REDUCTORES DE TORNILLO
SIN FIN

PT

PREDISPOSIÇÕES PARA
REDUTORES DE ROSCA
SEM FIM

M-P

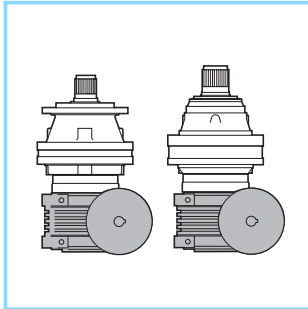

C37

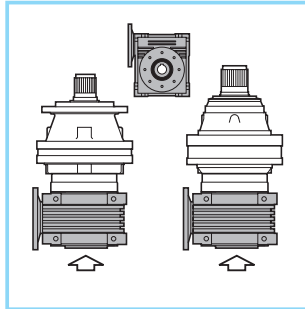

C38

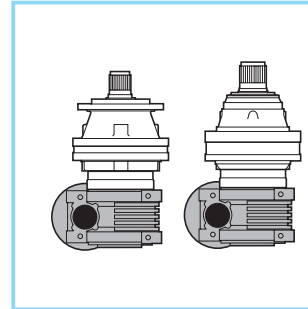

C39

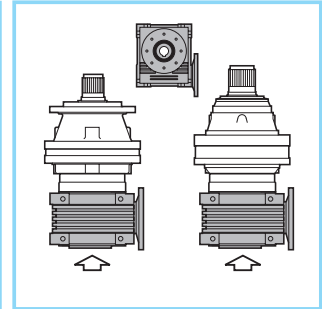

C40

F

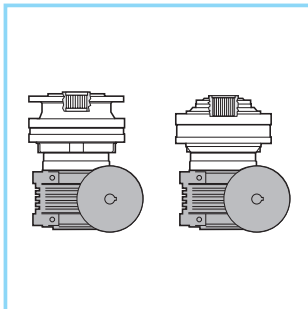

C37

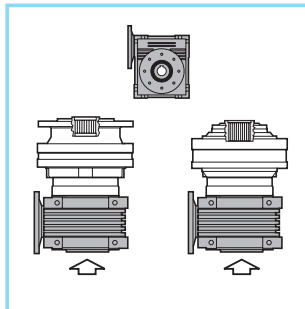

C38

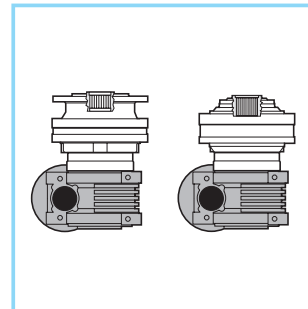

C39

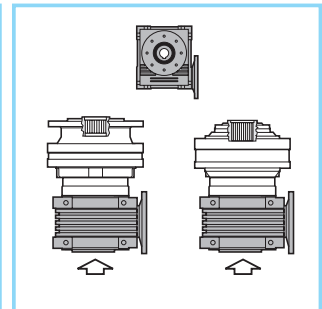

C40

FS

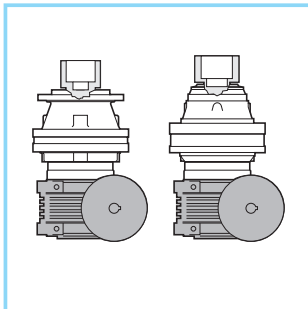

C37

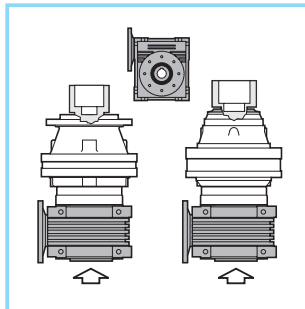

C38

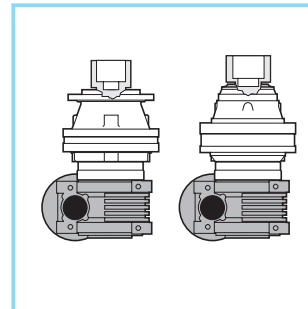

C39

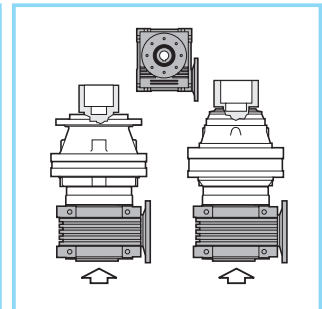

C40

CPC

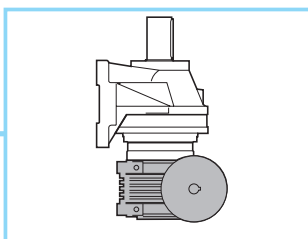

C65

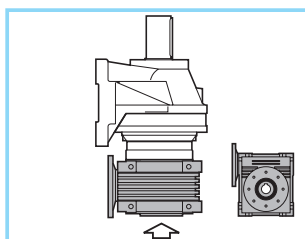

C66

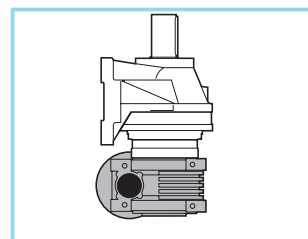

C67

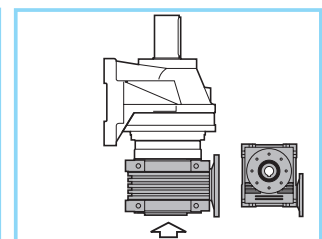

C68

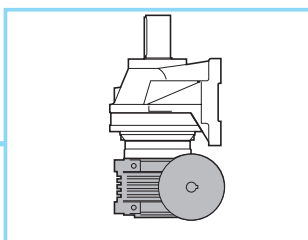

C69

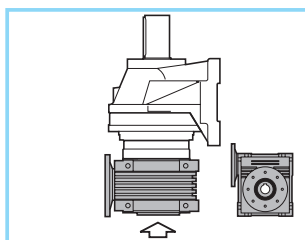

C70

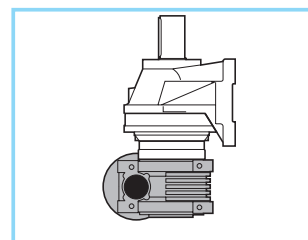

C71

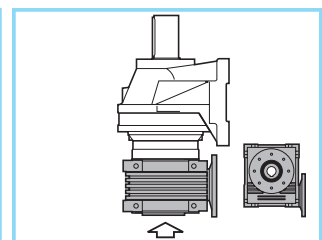

C72

