

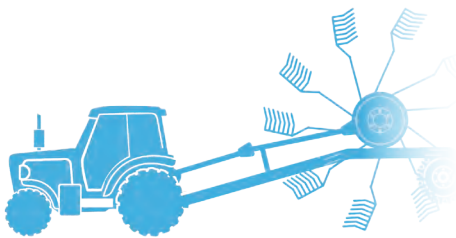

comer industries

DRIVESHAFTS

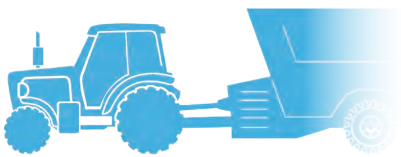

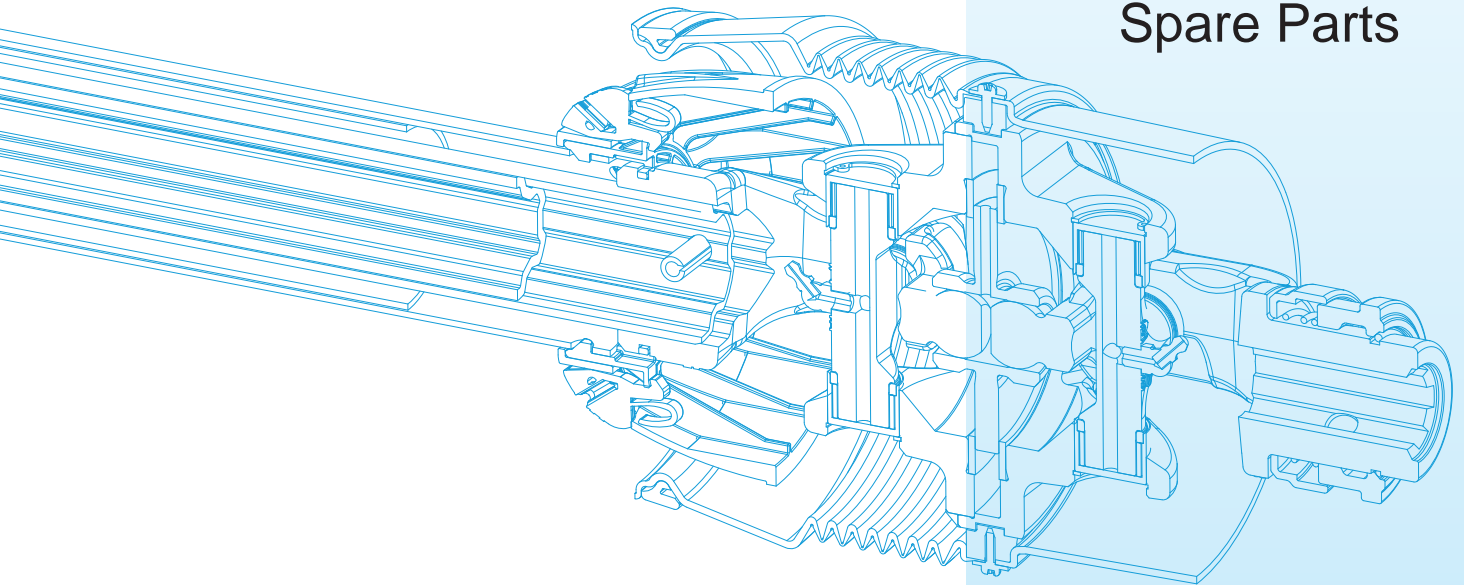







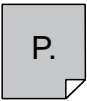



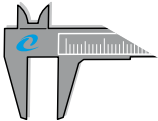

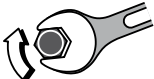
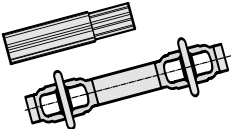
Spare Parts

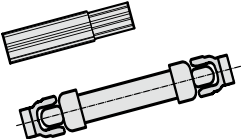

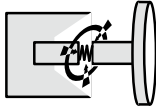
The easiest way to go far in agriculture

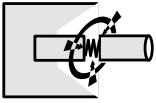
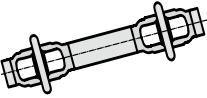
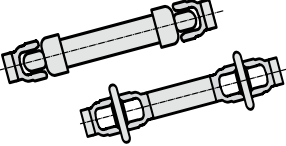
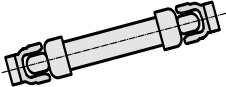
		p.
Simbologia	<i>Symbology</i>	3
Profilo aziendale	<i>Company Profile</i>	4
Teoria del giunto cardanico	<i>Cardan Joint Theory</i>	6
Caratteristiche cinematiche	<i>Kinematic Characteristics</i>	7
Nomogramma irregolarità di rotazione dell'albero cardanico	<i>PTO Driveshaft Rotation Irregularity Alignment Chart</i>	8
Giunto omocinetico	<i>CVJ Joint</i>	9
Potenze e coppie trasmissibili	<i>Power and Torque Ratings</i>	10
Calcolo durata crociere serie V-D	<i>Calculation of Cross and Bearings Kit Life V-D Series</i>	11
Calcolo durata crociere serie T-E	<i>Calculation of Cross and Bearings Kit Life T-E Series</i>	12
PARTI DI RICAMBIO SPARE PARTS		13
Programma di produzione alberi cardanici omocinetici	<i>CVJ PTO Driveshafts Production Program</i>	14
Programma di produzione alberi cardanici	<i>PTO Driveshafts Production Program</i>	16
Parti di ricambio alberi cardanici omocinetici	<i>CVJ PTO Driveshafts Spare Parts</i>	18
Parti di ricambio alberi cardanici	<i>PTO Driveshafts Spare Parts</i>	22
FORCELLE PER ALBERI CARDANICI E ALBERI CARDANICI OMOCINETICI YOKES FOR PTO DRIVESHAFTS AND CVJ PTO DRIVESHAFTS		27
Forcelle per alberi cardanici omocinetici	<i>Yokes for CVJ PTO Driveshafts</i>	28
Forcelle per alberi cardanici	<i>Yokes for PTO Driveshafts</i>	31
SNODI E FORCELLE DOPPIE JOINTS AND DOUBLE YOKES		45
Snodi per alberi cardanici omocinetici	<i>Joint for CVJ PTO Driveshafts</i>	46
Snodi per alberi cardanici	<i>Joint for PTO Driveshafts</i>	47
Forcelle doppie	<i>Double Yokes</i>	50
PROFILI PER ALBERI CARDANICI E ALBERI CARDANICI OMOCINETICI PROFILES FOR PTO DRIVESHAFTS AND CVJ PTO DRIVESHAFTS		53
Profili per alberi cardanici omocinetici	<i>Profile for CVJ PTO Driveshafts</i>	54
Profili per alberi cardanici	<i>Profile for PTO Driveshafts</i>	56
Codifica profili esterni serie V/T	<i>Outer Profiles Coding V/T Series</i>	60
DISPOSITIVI DI SICUREZZA INTEGRALI INTEGRAL SAFETY DEVICES		61
Programma di produzione	<i>Production Program</i>	62
B Limitatore a bullone di trancio	<i>Shear Bolt Torque Limiter</i>	66
M Limitatore a nottolini bidirezionale	<i>Bi-Directional Ratchet Clutch Torque Limiter</i>	68
R Ruota libera	<i>Overrunning Clutch</i>	70
F Frizione a dischi multipli	<i>Disc Clutch Torque Limiter</i>	72
W Frizione chiusa a dischi multipli	<i>Closed Disc Clutch Torque Limiter</i>	78
RB Limitatore a bullone di trancio con ruota libera	<i>Shear Bolt Torque Limiter with Overrunning Clutch</i>	83

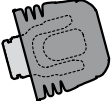
			p.
DISPOSITIVI DI SICUREZZA INTEGRALI INTEGRAL SAFETY DEVICES			
RF	Frizione a dischi multipli con ruota libera	<i>Disc Clutch Torque Limiter with Overrunning Clutch</i>	85
RW	Frizione chiusa con ruota libera	<i>Closed Disc Clutch Torque Limiter with Overrunning Clutch</i>	91
FM MM RM	Dispositivi con albero maschio	<i>Devices with Male Shaft</i>	95
DISPOSITIVI DI SICUREZZA FLANGIATI MODULAR SAFETY DEVICES			97
	Programma di produzione	<i>Production Program</i>	98
BF	Limitatore a bullone di trancio	<i>Shear Bolt Torque Limiter</i>	100
L	Limitatore automatico	<i>Automatic Torque Limiter</i>	102
WF	Frizione chiusa a dischi multipli	<i>Closed Disc Clutch Torque Limiter</i>	104
JF	Frizione semiaperta a dischi multipli	<i>Half Opened Disc Clutch Torque Limiter</i>	109
RJF	Frizione semiaperta con ruota libera	<i>Half Opened Disc Clutch Torque Limiter with Overrunning Clutch</i>	112
LRF	Limitatore automatico con ruota libera	<i>Automatic Torque Limiter with Overrunning Clutch</i>	116
PROTEZIONI GUARDS			120
	Codifica d'ordine	<i>Order Code</i>	121
	Protezioni F-CE per alberi cardanici omocineticici	<i>F-CE Guards for CVJ PTO Driveshafts</i>	122
	Protezioni F-CE per alberi cardanici	<i>F-CE Guards for PTO Driveshafts</i>	127
	Accessori F-CE	<i>F-CE Accessories</i>	130
	Protezioni N-EN per alberi cardanici omocineticici	<i>N-EN Guards for CVJ PTO Driveshafts</i>	132
	Protezioni N-EN per alberi cardanici	<i>N-EN Guards for PTO Driveshafts</i>	137
	Accessori N-EN	<i>N-EN Accessories</i>	140
	Controcuffie	<i>Counter-Cones</i>	142
SICUREZZA SAFETY			145
	Alberi cardanici	<i>PTO Driveshafts</i>	146
	Norme d'uso	<i>Rules of Use</i>	149
	Norme generali	<i>General Rules</i>	151
	Norme generali di sicurezza per controcuffie	<i>General Safety Rules for Counter-Cones</i>	152
	Dimensioni profili	<i>Splined Dimensions</i>	154
	Conversioni unità di misura	<i>Measurement Units Conversions</i>	155

	Pagina Page		Forcelle per cardani omocinetici Yokes for CVJ PTO Driveshafts
	Coppia massima Max Torque		Forcelle per cardani Yokes for PTO Driveshafts
	Dimensioni Dimensions		Forcelle doppie Double Yokes
	Coppia di serraggio Tightening Torque		Profili per cardani omocinetici Yokes for CVJ PTO Driveshafts
	Attenzione Warning		Profili per cardani Yokes for PTO Driveshafts
	Snodi per cardani omocinetici Joints for CVJ PTO Driveshafts		Dispositivi di sicurezza flangiati Modular Safety Devices
	Snodi per cardani Joints for PTO Driveshafts		Dispositivi di sicurezza integrali Integral Safety Devices
	Cardani omocinetici CVJ PTO Driveshafts		Accessori per cardani e cardani omocinetici Accessories for PTO and CVJ PTO Driveshafts
	Cardani PTO Driveshafts		Sicurezza Safety
	Protezioni N-EN N-EN Guards		
	Protezioni F-CE F-CE Guards		

Comer Industries è leader globale nelle **soluzioni di meccatronica** e nei **sistemi integrati per la trasmissione di potenza**, destinati ai **principali costruttori mondiali di macchine per l'agricoltura e l'industria**.

L'attività produttiva è strutturata su **cinque stabilimenti in Italia** nelle province di Reggio Emilia, Mantova e Matera, a cui si aggiungono uno stabilimento in **Cina** (Pinghu) e uno in **India** (Bangalore).

Per sviluppare e testare soluzioni all'avanguardia, Comer Industries si avvale del proprio **Centro Ricerche di Meccatronica**, nato nel 1996 e dotato delle ultime tecnologie e strumenti di sperimentazione.

Comer Industries progetta, realizza e si propone al mercato con un'ampia gamma di **trasmissioni standard e soluzioni per la trasmissione di potenza personalizzate**, come gearboxes, driveshafts, planetary gearboxes e powertrain per applicazioni industriali e agricole.

Comer Industries propone un'ampia gamma di **cardani standard e omocineticici** per potenze trasmissibili da 12 KW a 144 KW. L'offerta di prodotti si completa con **dispositivi di sicurezza**, tra cui frizioni, ruote libere e limitatori di coppia.

La **gamma di alberi cardanici** è adatta a varie applicazioni e tipologie di macchine agricole. Le soluzioni possono essere integrate con altri prodotti Comer Industries di gamma quali Gearboxes e Planetary Drives per formare una **soluzione completa della trasmissione di potenza** richiesta dall'applicazione.

Comer Industries presidia i principali mercati esteri con le proprie **filiali commerciali** in Francia, Germania, Regno Unito, Stati Uniti, Brasile, Cina e India.



Comer Industries is a global leader in **mechatronic solutions** and **integrated systems for power transmission**, supplied to **major manufacturers of agricultural and industrial machinery** worldwide.

Industrial operations are structured in five plants in **Italy**, one facility in **China** (Pinghu) and one in **India** (Bangalore).

To develop and test advanced product solutions, Comer Industries relies on its **Mechatronics Research Center**, established in 1996 and equipped with the latest technologies and experimental tools.

Comer Industries designs, manufactures and offers a wide product range of **standard and highly customized advanced power transmissions** such as gearboxes, driveshafts, planetary gearboxes and powertrain for agricultural and industrial applications.

Comer Industries offers an extensive range of **standard driveshafts and constant velocity joints** for transmissible power from 12 KW to 144 KW. **Safety devices**, such as clutches, free wheels and torque limiters, complete the offer.

Driveshafts series is suitable for a wide variety of applications and agricultural equipment. These solutions can be integrated with other Comer Industries standard products from the ranges Gearboxes and Planetary Drives to form a **complete power transmission solution** as required by the specific application.

The company operates in the major world markets through its own **sales subsidiaries** in France, Germany, United Kingdom, United States, Brazil, China and India.



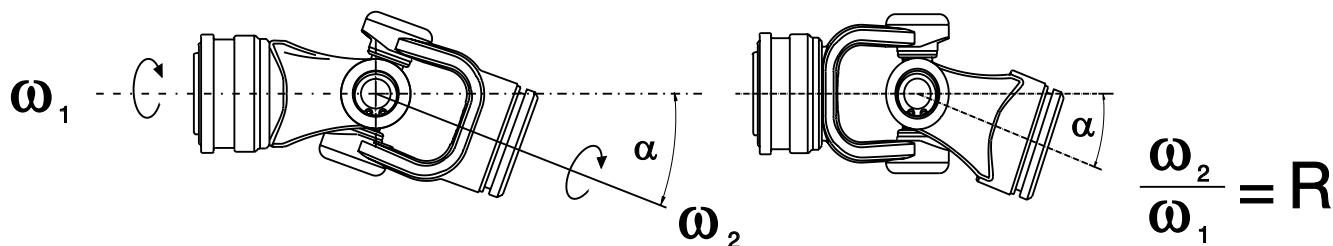

Fig.1

L'albero cardanico per uso agricolo è costituito da due giunti cardanici e da un accoppiamento telescopico.

Il giunto cardanico, composto da due forcelle e una crociera, è l'elemento che consente di trasmettere il moto fra due assi inclinati. La costruzione del giunto cardanico è tale che durante la rotazione la velocità dell'albero in uscita non è sempre uguale a quella dell'albero in ingresso e questa differenza di velocità dipende dall'angolo di snodo del giunto (Fig1).

The PTO driveshaft for agricultural applications consists of two cardan joints and a telescopic coupling.

The cardan joint, consisting of two yokes and a cross, is the element used to transmit the motion between two tilted axles. The cardan joint construction is designed so that during rotation, the speed of the output shaft is not always equal to that of the input shaft and this difference in speed depends on the articulation angle of the joint (Fig. 1).

Il rapporto di trasmissione in funzione dell'angolo di snodo e dell'angolo di rotazione è rappresentato in Fig.2. Più il rapporto si discosta dal valore 1 e più cresce l'irregolarità del moto con conseguente generazione di effetti indesiderati (vibrazioni, rumorosità, sollecitazioni inerziali).

The transmission ratio versus the articulation angle and the rotation angle is represented in Fig. 2. The more the ratio deviates from 1 the greater becomes the irregularity of the motion, thus generating undesirable effects (vibrations, noise, inertial stress).

Rapporto di trasmissione istantaneo
Instantaneous transmission ratio

α = angolo di snodo = articulation angle β = angolo di rotazione = rotation angle

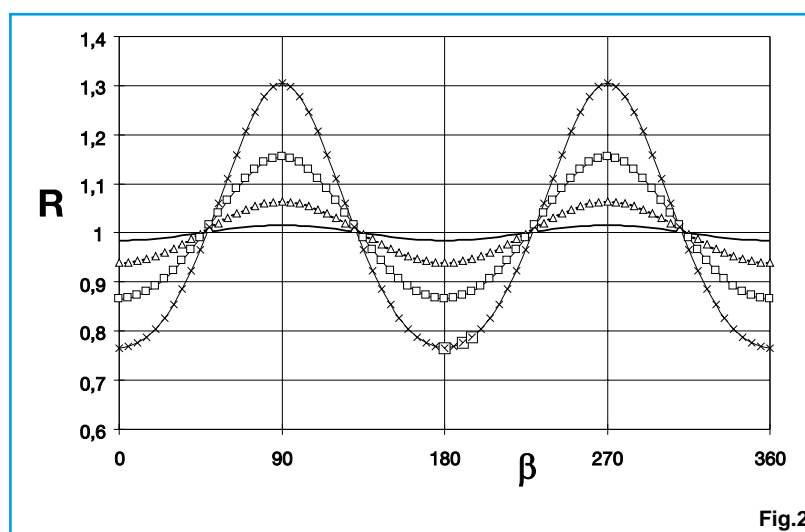

Fig.2

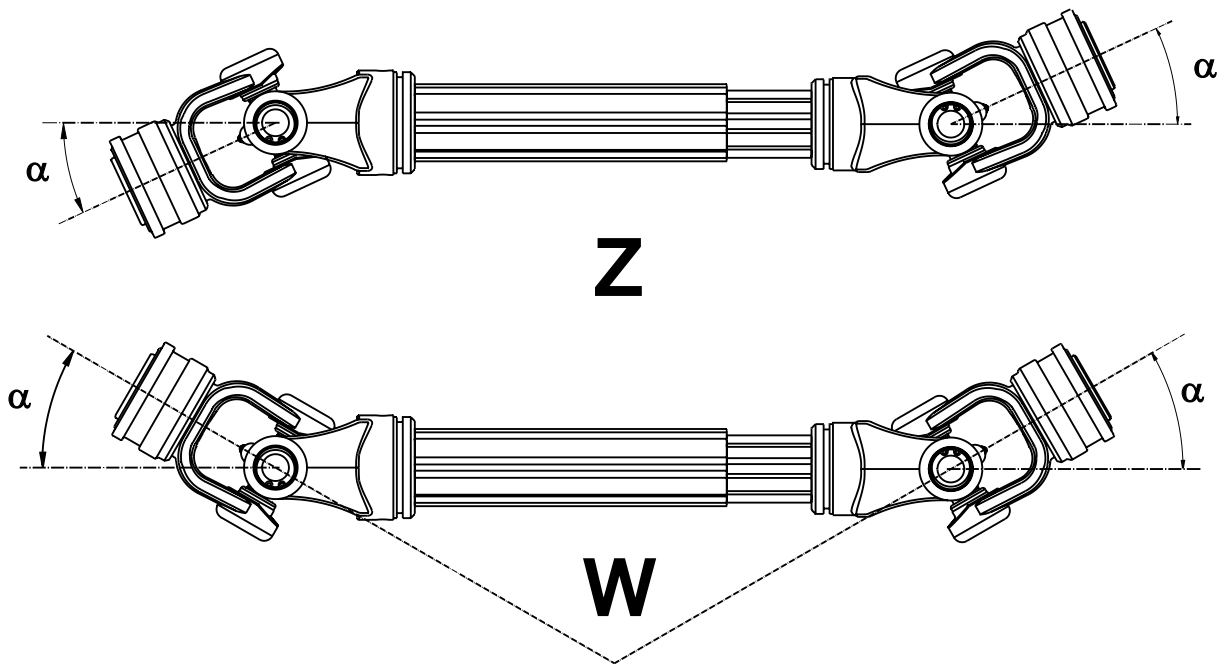

Fig.3

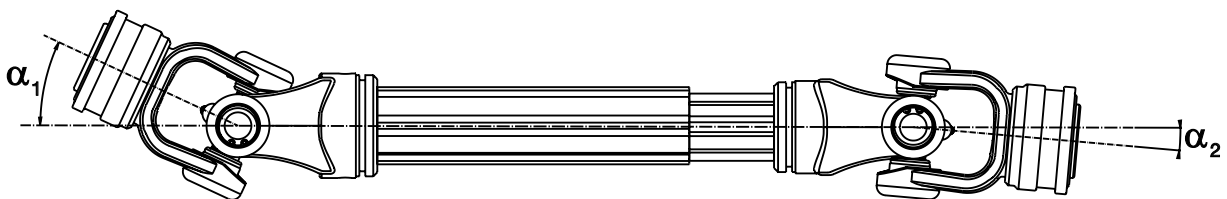

Fig.4

L'albero cardanico è composto da due giunti cardanici. Le irregolarità dei singoli giunti possono quindi eliminarsi o comporsi reciprocamente.

Quando gli angoli di snodo dei due giunti sono uguali, vedi disposizione W o disposizione Z (Fig.3), la trasmissione è omocinetica, cioè la velocità della forcella in uscita è sempre uguale a quella in ingresso, eliminando quindi gli effetti indesiderati.

In tutte le altre angolazioni (Fig.4) rimane sempre una irregolarità che può essere valutata con il grafico della pagina seguente (Fig.5).

The PTO driveshaft consists of two cardan joints. The irregularities of the single joints thus can be cancelled or mutually combined.

When the articulation angles of the two joints are equal (see configuration W or Z in Fig. 3) the transmission is uniform, i.e. the speed of the output yoke is always equal to the speed of the input yoke, thus eliminating the undesirable effects.

In all the other angulations (Fig. 4), an irregularity always remains that can be evaluated with the graph on the following page (Fig. 5).

NOMOGRAMMA IRREGOLARITA' DI ROTAZIONE DELL'ALBERO CARDANICO
PTO DRIVESHAFT ROTATION IRREGULARITY ALIGNMENT CHART

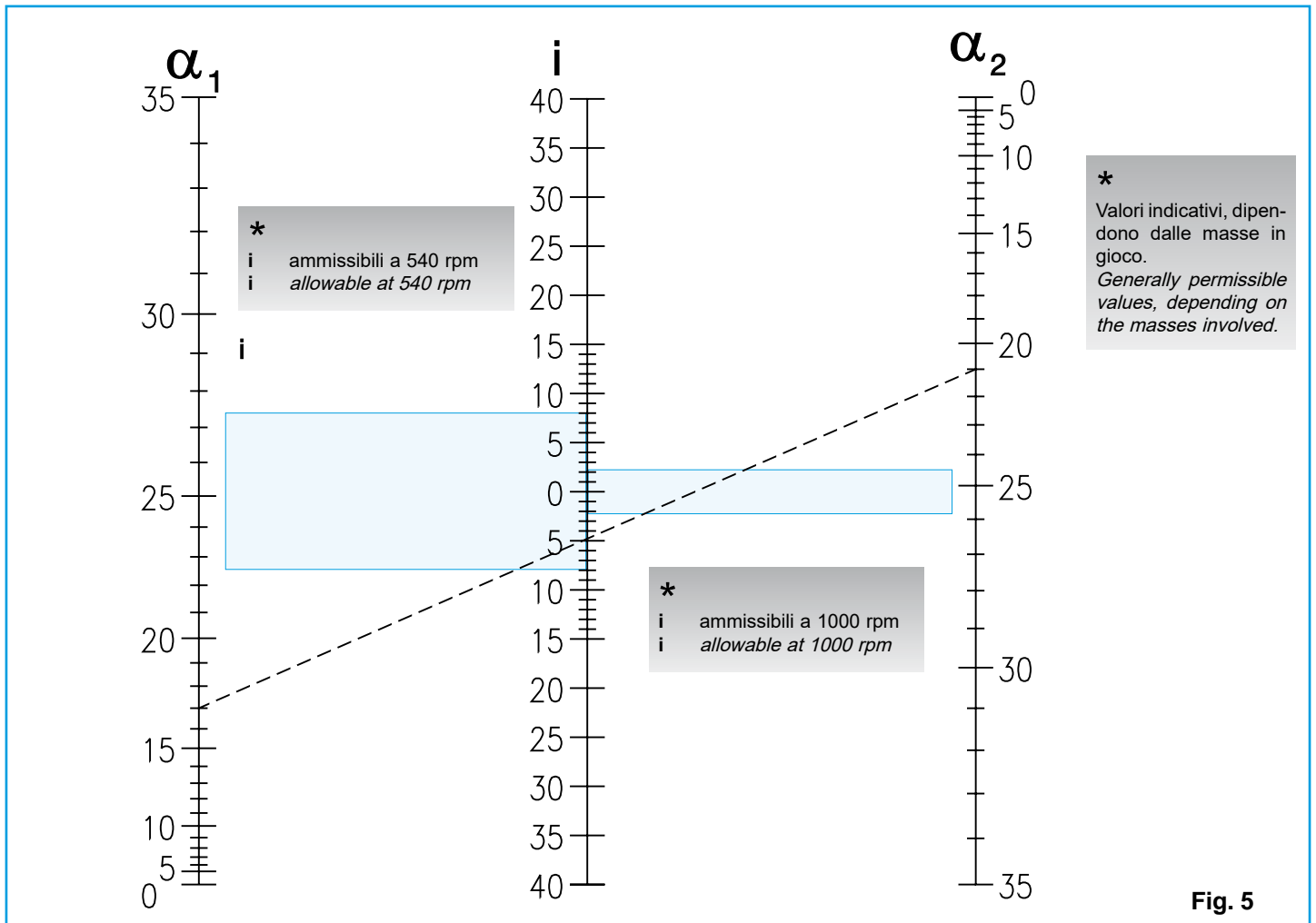
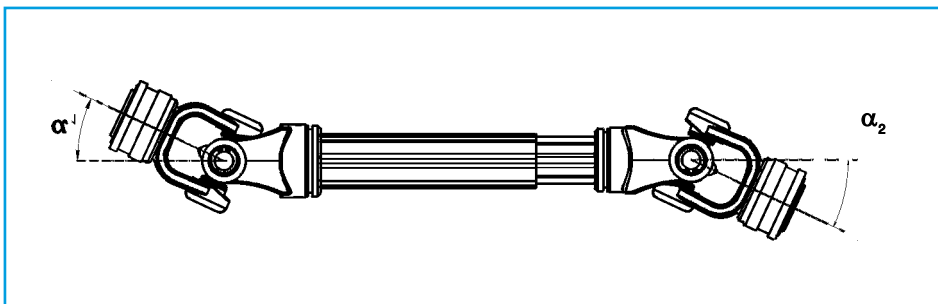

Fig. 5



Esempio / Example:

$\alpha_1 = 0^\circ, \alpha_2 = 4^\circ, \alpha_1 - \alpha_2 = 4^\circ$
 $i = 0,5\%$
 $\alpha_1 = 21^\circ, \alpha_2 = 25^\circ, \alpha_1 - \alpha_2 = 4^\circ$
 $i = 6\%$

L'irregolarità "i" del moto dipende dall' inclinazione dei due snodi cardanici e dalla differenza fra le angolazioni dei due snodi (vedi es.: a parità di differenza angolare l'irregolarità è maggiore se le inclinazioni dei singoli snodi sono maggiori).

Irregularity "i" of the motion depends on the articulation of the two cardan joints and on the difference between the articulations of the two joints (see the example: with angular difference being equal, the irregularity is greater if the articulations of the single joints are greater).

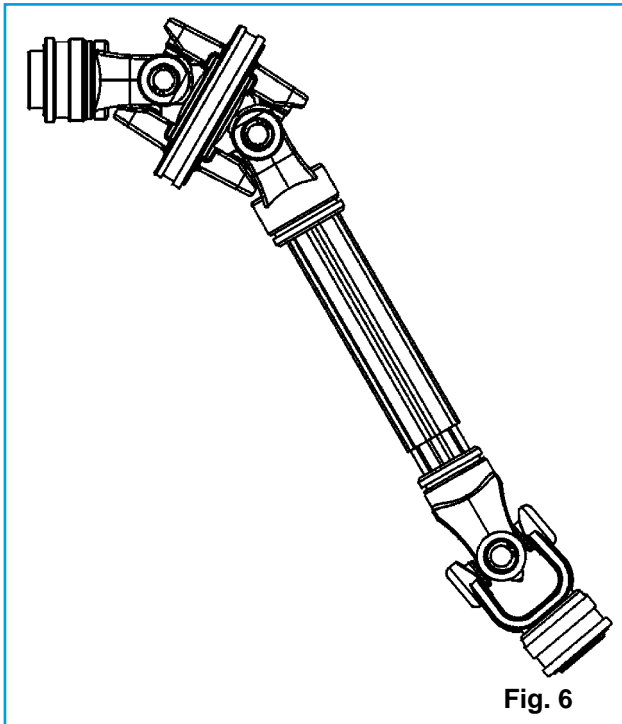

Fig. 6

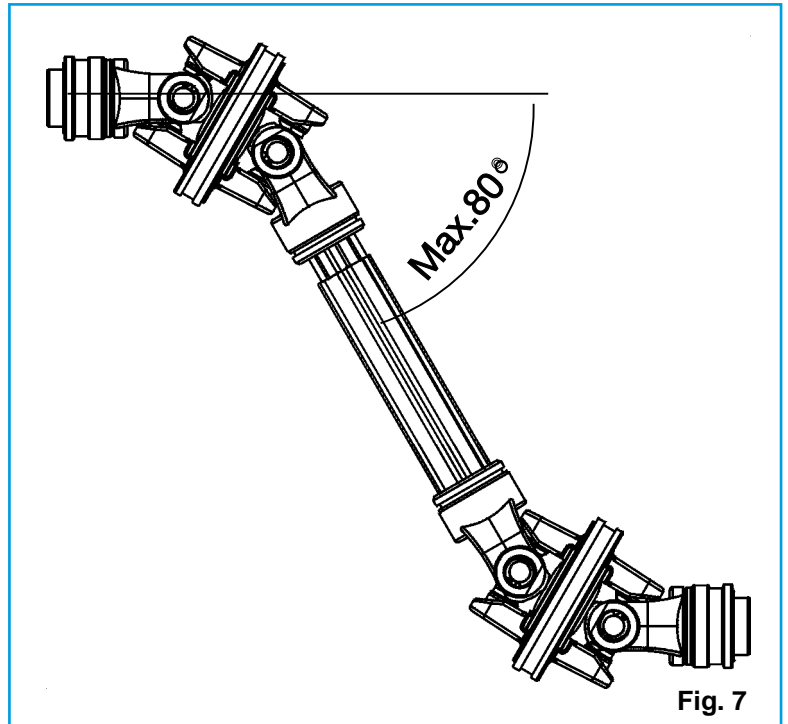

Fig. 7

Il giunto omocinetico (giunto a velocità costante) è un doppio snodo con un sistema di centraggio che garantisce una eguale ripartizione dell'angolo di snodo fra le due forcelle (disposizione a W). La velocità della forcella in uscita è sempre uguale a quella in ingresso e non vi sono irregolarità di rotazione.

In un albero cardanico con giunto omocinetico e un giunto standard (Fig.6), l'irregolarità totale è dovuta al solo giunto standard, che perciò deve lavorare a piccoli angoli di snodo. Nel caso di elevati angoli di lavoro alle due estremità dell'albero è necessario utilizzare due snodi omocinetici (Fig.7).

Il giunto omocinetico può lavorare ad elevati angoli di snodo solo per brevi periodi (es. durante una sterzata). Caratteristica costruttiva di assoluta qualità ed affidabilità del giunto omocinetico è l'adozione di un ponte sfera saldato alla forcella, che permette di ridurre consistentemente le sollecitazioni e quindi le usure nella zona di contatto sfera-cilindro e nell'accoppiamento scanalato tra albero e forcella.

The CVJ joint (Constant Velocity Joint) is a double universal joint with a centering system that equally divides the articulation angle between the two yokes (W configuration). The speed of the output yoke is always equal to the input speed and there are no rotation irregularities.

In a PTO driveshaft with a CVJ joint and a standard joint (Fig. 6), the total irregularity is caused only by the standard joint, that therefore must work with small articulation angles. For high work angles at the two ends of the shaft, two CVJ joints must be used (Fig. 7).

The CVJ joint can work with high articulation angles only for brief periods (ex.: while steering). Absolute quality and reliability of the CVJ construction are ensured by the ball bridge welded to the yoke which considerably reduces stress and consequently wears in the ball-cylinder contact zone and in the splined coupling between the shaft and the yoke.

POTENZE E COPPIE TRASMISSIBILI
POWER AND TORQUE RATINGS

Type	540 [rpm]					1000 [rpm]				* Coppia dinamica max. Max. Dynamic Torque	
	Power		Torque			Power		Torque			
	[kW]	[cv]	[Nm]	[in.lb.]	[kW]	[cv]	[Nm]	[in.lb.]	[Nm]	[in.lb.]	
V	20	17	23	300	2650	26	36	250	2200	460	4050
	40	28	38	490	4310	43	58	410	3600	850	7530
	50	37	50	650	5750	57	77	540	4750	1100	9740
	60	50	68	880	7790	77	105	740	6510	1510	13360
	80	74	100	1300	11500	113	154	1080	9550	2390	21150
	90	88	120	1560	13800	140	190	1340	11850	2900	25700

T	10	12	16	210	1850	18	25	172	1500	320	2850
	20	15	21	270	2400	23	31	220	1950	450	4000
	40	26	35	460	4050	40	55	380	3350	780	6900
	50	35	47	620	5500	54	74	520	4600	1050	9300
	60	47	64	830	7350	74	100	710	6259	1450	12850
	80	70	95	1240	10950	110	150	1050	9300	2250	19900
	90	88	120	1560	13800	140	190	1340	11850	2900	25700

E	40	26	35	460	4050	40	55	380	3350	780	6900
	50	35	47	620	5500	54	74	520	4600	1050	9300
	60	47	64	830	7350	74	100	710	6259	1450	12850
	80	70	95	1240	10950	110	150	1050	9300	2250	19900
	90	88	120	1560	13800	140	190	1340	11850	2900	25700

D	120	144	196	2546	22535	221	300	2110	18675	6500	57530
----------	------------	-----	-----	------	-------	-----	-----	------	-------	------	-------

* E' la massima coppia trasmissibile in rotazione. Rappresenta il massimo valore di coppia applicabile per il quale la durata può essere determinata mediante il nomogramma.

* It is the max. transmissible torque during the rotation. It represents the max. applicable torque value whom duration can be determined through the alignment chart.

Valori e condizioni di lavoro continuo, angolo di snodo 5°, durata 1000 ore.

Continuous operation data and conditions, working angle 5°, average life 1000 hours.

CALCOLO DURATA CROCIERE SERIE V-D
CALCULATION OF CROSS AND BEARING KIT LIFE V-D SERIES

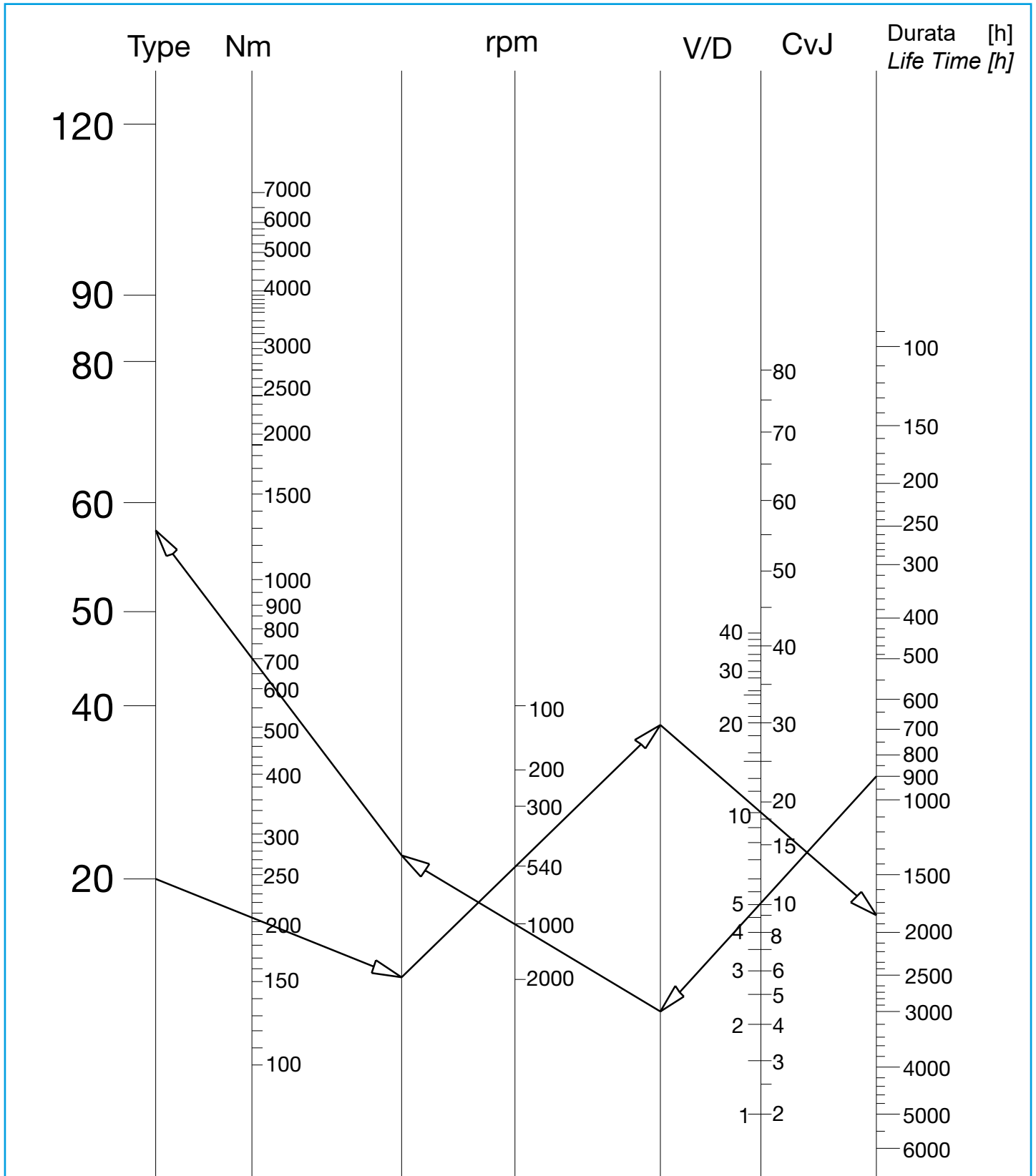

Esempio	V 20	210 Nm.	540 rpm	10°	1800 h	
Example	900 h	10°	(CVJ)	1000 rpm	700 Nm	CVJ V60
	900 h	5°	(V)	1000 rpm	700 Nm	V60

CALCOLO DURATA CROCIERE SERIE T-E
CALCULATION OF CROSS AND BEARING KIT LIFE T-E SERIES

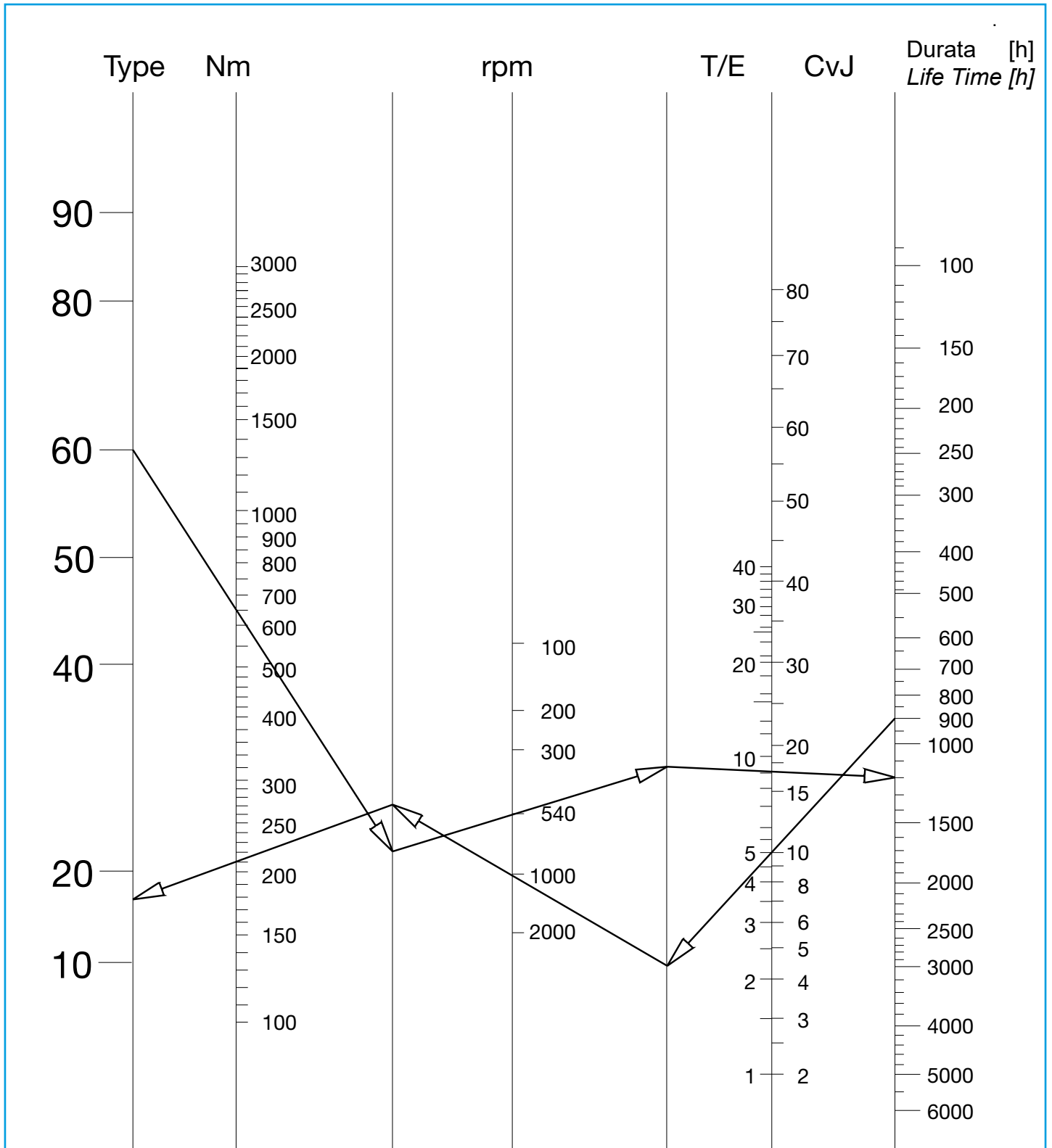

Esempio	T 60	650 Nm.	540 rpm	9°	1200 h	
Example	900 h	10°	(CVJ)	1000 rpm	210 Nm	CVJ T20
	900 h	5°	(T)	1000 rpm	210 Nm	T20

PARTI DI RICAMBIO SPARE PARTS

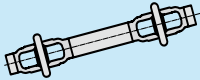
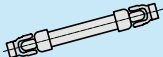
CARDANI OMOCINETICI CVJ PTO DRIVESHAFTS CVJ				p.
Programma di produzione	Production Program			14
	Serie V	V Series		14
	Serie T	T Series		15
Parti di ricambio	Spare Parts			
	Serie V singolo CVJ	V Series single CVJ		18
	Serie V doppio CVJ	V Series double CVJ		19
	Serie T singolo CVJ	T Series single CVJ		20
	Serie T doppio CVJ	T Series double CVJ		21
CARDANI STANDARD PTO DRIVESHAFTS				
Programma di produzione	Production Program			16
	Serie V	V Series		16
	Serie T	T Series		16
	Serie E	E Series		17
	Serie D	D Series		17
Parti di ricambio	Spare Parts			
	Serie V	V Series		22
	Serie T	T Series		23
	Serie E	E Series		24
	Serie D	D Series		25

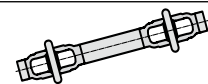

Type	Crociera Cross and bearing kit	Corpo centrale Double yoke	Forcella per tubo esterno Outer tube yoke	Tubo esterno Outer tube	Tubo interno Inner tube	Forcella per tubo interno Inner tube yoke
20	 Code 180.012.161	 Code 141.022.160.1	 Code 141.022.325.1	 pag. 54	 pag. 54	 Code 151.012.320.1
	 Code 180.014.260	 Code 141.024.259.1	 Code 141.024.433.1	 pag. 54	 pag. 54	 Code 151.014.428.1
	 Code 180.016.228	 Code 141.026.224.1	 Code 141.026.390.1	 pag. 54	 pag. 54	 Code 151.016.389.1
	 Code 180.018.158	 Code 141.028.157.1	 Code 141.028.248.1	 pag. 54	 pag. 54	 Code 151.018.242.1
20	 Code 180.012.161	 Code 141.022.160.1	 Code 141.022.325.1	 pag. 54	 pag. 54	 Code 141.022.326.1
	 Code 180.014.260	 Code 141.024.259.1	 Code 141.024.433.1	 pag. 54	 pag. 54	 Code 141.024.434.1
	 Code 180.016.228	 Code 141.026.224.1	 Code 141.026.390.1	 pag. 54	 pag. 54	 Code 141.026.391.1
	 Code 180.018.158	 Code 141.028.157.1	 Code 141.028.248.1	 pag. 54	 pag. 54	 Code 141.028.249.1

**serie
series** **V** snodo singolo
single joint



**serie
series** **V** snodo doppio
double joint



**PROGRAMMA DI PRODUZIONE
PRODUCTION PROGRAM**

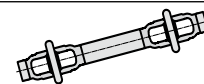

Parti di ricambio
Spare Parts

Type	Crociera Cross and bearing kit	Corpo centrale Double yoke	Forcella per tubo esterno Outer tube yoke	Tubo esterno Outer tube	Tubo interno Inner tube	Forcella per tubo interno Inner tube yoke
20	 Code 180.012.161	 Code 141.022.160.1	 Code 141.022.166.1	 pag. 55	 pag. 55	 Code 151.012.002.1
	 Code 180.014.260	 Code 141.024.259.1	 Code 141.024.263.1	 pag. 55	 pag. 55	 Code 151.014.007.1
	 Code 180.016.228	 Code 141.026.224.1	 Code 141.026.229.1	 pag. 55	 pag. 55	 Code 151.016.029.1
	 Code 180.018.158	 Code 141.028.157.1	 Code 141.028.152.1	 pag. 55	 pag. 55	 Code 151.018.134.1
20	 Code 180.012.161	 Code 141.022.160.1	 Code 141.022.166.1	 pag. 55	 pag. 55	 Code 141.022.172.1
	 Code 180.014.260	 Code 141.024.259.1	 Code 141.024.263.1	 pag. 55	 pag. 55	 Code 141.024.269.1
	 Code 180.016.228	 Code 141.026.224.1	 Code 141.026.229.1	 pag. 55	 pag. 55	 Code 141.026.249.1
	 Code 180.018.158	 Code 141.028.157.1	 Code 141.028.152.1	 pag. 55	 pag. 55	 Code 141.028.165.1

serie
series

T
snodo singolo
single joint



serie
series

T
snodo doppio
double joint



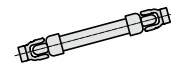

Type	Crociera Cross and bearing kit	Forcella per tubo esterno Outer tube yoke	Tubo esterno Outer tube	Tubo interno Inner tube	Forcella per tubo interno Inner tube yoke
20	 Code 180.012.004	 Code 151.012.319.1	 pag. 56	 pag. 56	 Code 151.012.320.1
40	 Code 180.014.004	 Code 151.014.427.1	 pag. 56	 pag. 56	 Code 151.014.428.1
50	 Code 180.015.004	 Code 151.015.361.1	 pag. 56	 pag. 56	 Code 151.015.362.1
60	 Code 180.016.004	 Code 151.016.388.1	 pag. 56	 pag. 56	 Code 151.016.389.1
80	 Code 180.018.004	 Code 151.018.241.1	 pag. 56	 pag. 56	 Code 151.018.242.1
90	 Code 180.019.043	 Code 151.019.166.1	 pag. 56	 pag. 56	 Code 151.019.167.1
10	 Code 180.011.130	 Code 151.011.003.1	 pag. 57	 pag. 57	 Code 151.011.002.1
20	 Code 180.012.130	 Code 151.012.003.1	 pag. 57	 pag. 57	 Code 151.012.002.1
40	 Code 180.014.130	 Code 151.014.006.1	 pag. 57	 pag. 57	 Code 151.014.007.1
50	 Code 180.015.130	 Code 151.015.011.1	 pag. 57	 pag. 57	 Code 151.015.012.1
60	 Code 180.016.130	 Code 151.016.028.1	 pag. 57	 pag. 57	 Code 151.016.029.1

STANDARD

V
serie
series



T
serie
series



SERIE V SINGOLO CVJ V SERIES SINGLE CVJ

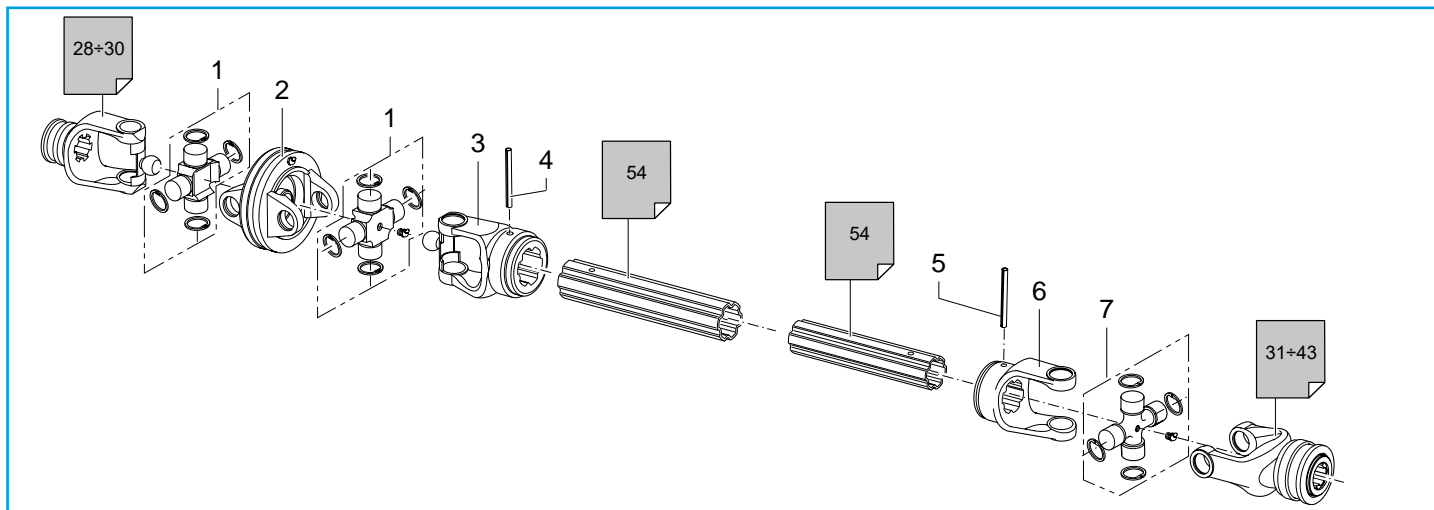
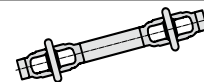

Pos.		
1	Crociera completa (CVJ)	Cross and bearing kit (CVJ)
2	Corpo centrale	Double yoke
3	Forcella per tubo esterno (CVJ)	Outer tube yoke (CVJ)
4	Spina elastica esterna	Outer roll pin
5	Spina elastica interna	Inner roll pin
6	Forcella per tubo interno (std)	Inner tube yoke (std)
7	Crociera completa (std)	Cross and bearing kit (std)

Pos.	Type	Type				Qty*
		20	40	60	80	
1 	[mm]	A = \varnothing 23.8 B = 74.1 C = 82.1	A = \varnothing 27 B = 85.8 C = 91.2	A = \varnothing 30.2 B = 95.4 C = 101.4	A = \varnothing 35 B = 106.3 C = 113.8	2
	Code	180.012.161	180.014.260	180.016.228	180.018.158	
2 	[mm]	A = 86	A = 95	A = 104	A = 118	1
	Code	141.022.160.1	141.024.259.1	141.026.224.1	141.028.157.1	
3 	[mm]	A = 23.8 B = 76.5 C = 80 D = 22 E = 22 F = \varnothing 42	A = 27 B = 88.2 C = 91.5 D = 24 E = 24 F = \varnothing 45.7	A = 30.2 B = 98.4 C = 104 D = 24 E = 27 F = \varnothing 57.6	A = 35 B = 109.3 C = 120 D = 27 E = 30 F = \varnothing 66.5	1
	Code	141.022.325.1	141.024.433.1	141.026.390.1	141.028.248.1	
4 	[mm]	A = 55 B = \varnothing 8	A = 65 B = \varnothing 8	A = 80 B = \varnothing 10	A = 90 B = \varnothing 12	1
	Code	190.000.012	190.000.014	190.000.018	190.000.243	
5 	[mm]	A = 50 B = \varnothing 8	A = 55 B = \varnothing 8	A = 70 B = \varnothing 10	A = 80 B = \varnothing 12	1
	Code	190.000.011	190.000.012	190.000.016	190.000.271	
6 	[mm]	A = 23.8 B = 63.9 C = 80 D = 21 F = \varnothing 36.2	A = 27 B = 77.2 C = 91.5 D = 24 F = \varnothing 39.3	A = 30.2 B = 94.6 C = 104 D = 24 F = \varnothing 50.2	A = 35 B = 109.6 C = 116 D = 24 F = \varnothing 58.1	1
	Code	151.012.320.1	151.014.428.1	151.016.389.1	151.018.242.1	
7 	[mm]	A = \varnothing 23.8 B = 61.3	A = \varnothing 27 B = 74.6	A = \varnothing 30.2 B = 92	A = \varnothing 35 B = 106.5	1
	Code	180.012.004	180.014.004	180.016.004	180.018.004	

* Quantità presente nel cardano / Quantity in the PTO driveshaft

SERIE V DOPPIO CVJ V SERIES DOUBLE CVJ

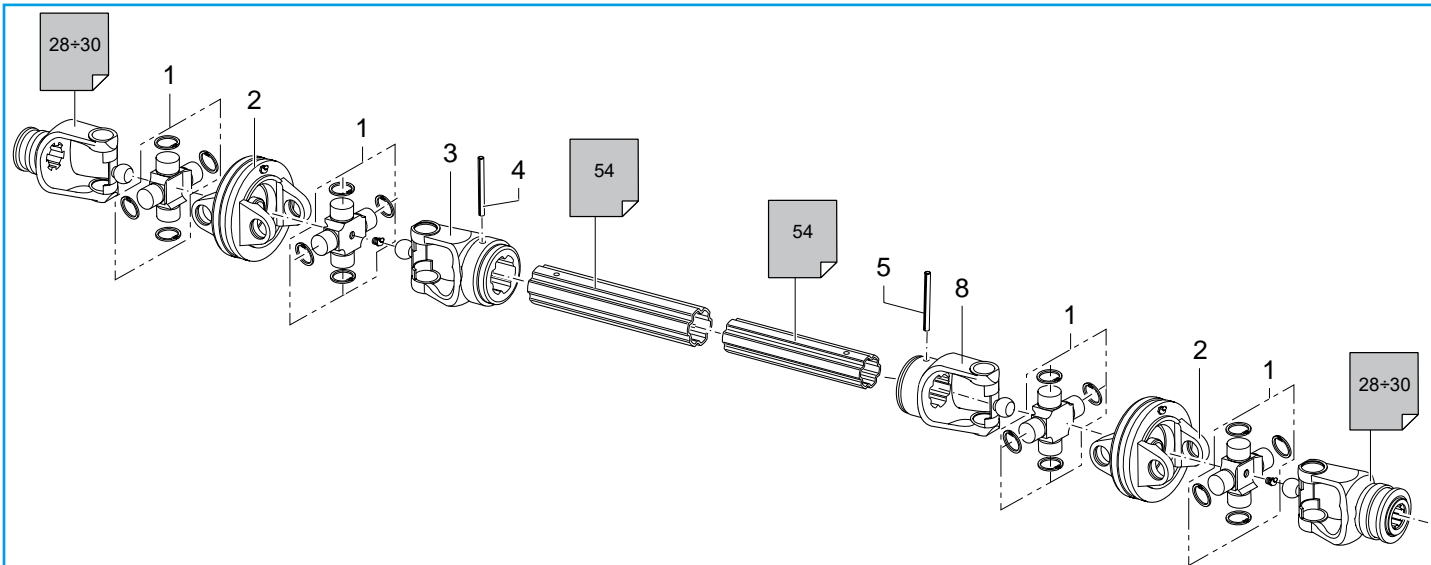
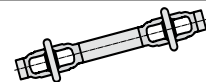

Pos.		
1	Crociera completa (CVJ)	Cross and bearing kit (CVJ)
2	Corpo centrale	Double yoke
3	Forcella per tubo esterno (CVJ)	Outer tube yoke (CVJ)
4	Spina elastica esterna	Outer roll pin
5	Spina elastica interna	Inner roll pin
8	Forcella per tubo interno (std)	Inner tube yoke (std)

Pos.	Type	Type				Qty*	
		20	40	60	80		
1		[mm]	A = \varnothing 23.8 B = 74.1 C = 82.1	A = \varnothing 27 B = 85.8 C = 91.2	A = \varnothing 30.2 B = 95.4 C = 101.4	A = \varnothing 35 B = 106.3 C = 113.8	4
		Code	180.012.161	180.014.260	180.016.228	180.018.158	
2		[mm]	A = 86	A = 95	A = 104	A = 118	1
		Code	141.022.160.1	141.024.259.1	141.026.224.1	141.028.157.1	
3		[mm]	A = 23.8 B = 76.5 C = 80 D = 22 E = 22 F = \varnothing 42	A = 27 B = 88.2 C = 91.5 D = 24 E = 24 F = \varnothing 45.7	A = 30.2 B = 98.4 C = 104 D = 24 E = 27 F = \varnothing 57.6	A = 35 B = 109.3 C = 120 D = 27 E = 30 F = \varnothing 66.5	1
		Code	141.022.325.1	141.024.433.1	141.026.390.1	141.028.248.1	
4		[mm]	A = 55 B = \varnothing 8	A = 65 B = \varnothing 8	A = 80 B = \varnothing 10	A = 90 B = \varnothing 12	1
		Code	190.000.012	190.000.014	190.000.018	190.000.243	
5		[mm]	A = 50 B = \varnothing 8	A = 55 B = \varnothing 8	A = 70 B = \varnothing 10	A = 80 B = \varnothing 12	1
		Code	190.000.011	190.000.012	190.000.016	190.000.271	
8		[mm]	A = 23.8 B = 76.5 C = 80 D = 21 E = 22 F = \varnothing 36.2	A = 27 B = 88.2 C = 91.5 D = 24 E = 24 F = \varnothing 39.3	A = 30.2 B = 98.4 C = 104 D = 24 E = 27 F = \varnothing 50.2	A = 35 B = 109.3 C = 120 D = 24 E = 30 F = \varnothing 58.1	1
		Code	141.022.326.1	141.024.434.1	141.026.391.1	141.028.249.1	

* Quantità presente nel cardano / Quantity in the PTO driveshaft

SERIE T SINGOLO CVJ
T SERIES SINGLE CVJ

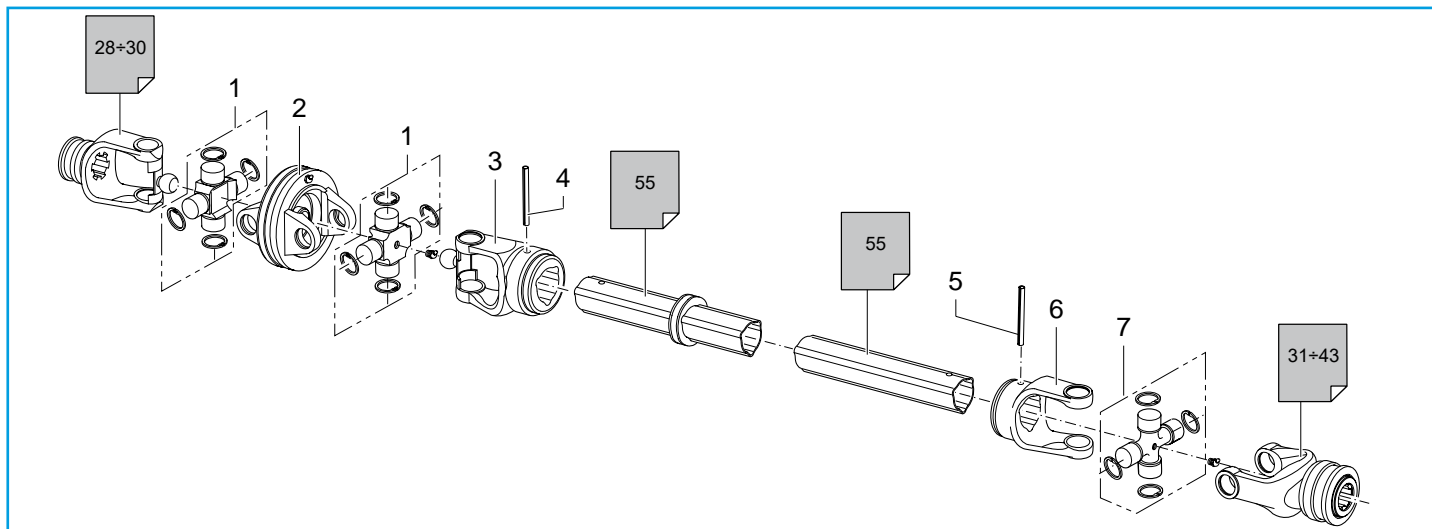
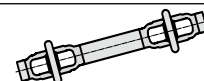

Pos.		
1	Crociera completa (CVJ)	Cross and bearing kit (CVJ)
2	Corpo centrale	Double yoke
3	Forcella per tubo esterno (CVJ)	Outer tube yoke (CVJ)
4	Spina elastica esterna	Outer roll pin
5	Spina elastica interna	Inner roll pin
6	Forcella per tubo interno (std)	Inner tube yoke (std)
7	Crociera completa (std)	Cross and bearing kit (std)

Pos.	Type	Type				Qty*	
		20	40	60	80		
1		[mm]	A = \varnothing 23.8 B = 74.1 C = 82.1	A = \varnothing 27 B = 85.8 C = 91.2	A = \varnothing 30.2 B = 95.4 C = 101.4	A = \varnothing 35 B = 106.3 C = 113.8	2
		Code	180.012.161	180.014.260	180.016.228	180.018.158	
2		[mm]	A = 86	A = 95	A = 104	A = 118	1
		Code	141.022.160.1	141.024.259.1	141.026.224.1	141.028.157.1	
3		[mm]	A = 23.8 B = 76.5 C = 80 D = 22 E = 22 F = 36	A = 27 B = 88.2 C = 91.5 D = 24 E = 24 F = 43.5	A = 30.2 B = 98.4 C = 104 D = 24 E = 27 F = 54	A = 35 B = 109.3 C = 120 D = 27 E = 30 F = 63	1
		Code	141.022.166.1	141.024.263.1	141.026.229.1	141.028.152.1	
4		[mm]	A = 55 B = \varnothing 8	A = 65 B = \varnothing 8	A = 80 B = \varnothing 10	A = 90 B = \varnothing 12	1
		Code	190.000.012	190.000.014	190.000.018	190.000.243	
5		[mm]	A = 50 B = \varnothing 8	A = 55 B = \varnothing 8	A = 70 B = \varnothing 10	A = 80 B = \varnothing 12	1
		Code	190.000.011	190.000.012	190.000.016	190.000.271	
6		[mm]	A = 23.8 B = 63.9 C = 80 D = 21 F = 29	A = 27 B = 77.2 C = 91.5 D = 24 F = 36	A = 30.2 B = 94.6 C = 104 D = 24 F = 45	A = 35 B = 109.6 C = 116 D = 24 F = 54	1
		Code	151.012.002.1	151.014.007.1	151.016.029.1	151.018.134.1	
7		[mm]	A = \varnothing 23.8 B = 61.3	A = \varnothing 27 B = 74.6	A = \varnothing 30.2 B = 92	A = \varnothing 35 B = 106.5	1
		Code	180.012.004	180.014.004	180.016.004	180.018.004	

* Quantità presente nel cardano / Quantity in the PTO driveshaft

SERIE T DOPPIO CVJ T SERIES DOUBLE CVJ

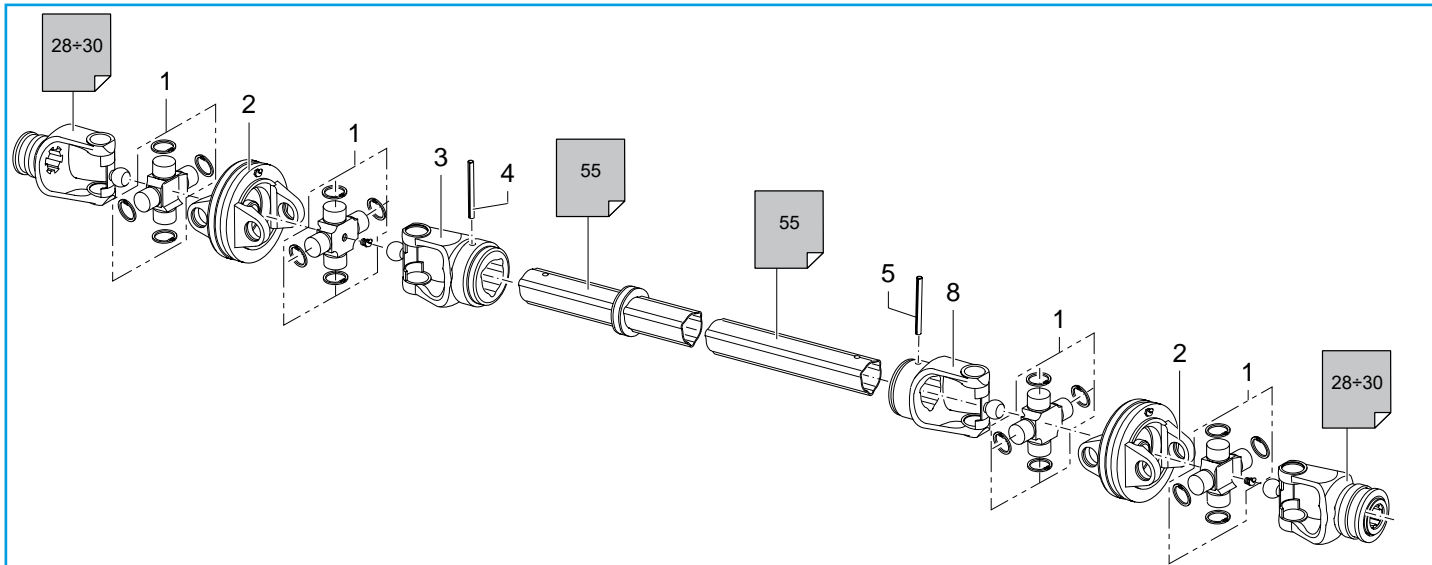
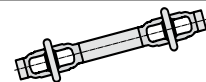

Pos.		
1	Crociera completa (CVJ)	Cross and bearing kit (CVJ)
2	Corpo centrale	Double yoke
3	Forcella per tubo esterno (CVJ)	Outer tube yoke (CVJ)
4	Spina elastica esterna	Outer roll pin
5	Spina elastica interna	Inner roll pin
8	Forcella per tubo interno (std)	Inner tube yoke (std)

Pos.	[mm]	Type				Qty*
		20	40	60	80	
1	A = \varnothing 23.8 B = 74.1 C = 82.1	A = \varnothing 27 B = 85.8 C = 91.2	A = \varnothing 30.2 B = 95.4 C = 101.4	A = \varnothing 35 B = 106.3 C = 113.8	4	
	Code	180.012.161	180.014.260	180.016.228		180.018.158
2	A = 86	A = 95	A = 104	A = 118	1	
	Code	141.022.160.1	141.024.259.1	141.026.224.1		141.028.157.1
3	A = 23.8 B = 76.5 C = 80 D = 22 E = 22 F = 36	A = 27 B = 88.2 C = 91.5 D = 24 E = 24 F = 43.5	A = 30.2 B = 98.4 C = 104 D = 24 E = 27 F = 54	A = 35 B = 109.3 C = 120 D = 27 E = 30 F = 63	1	
	Code	141.022.166.1	141.024.263.1	141.026.229.1		141.028.152.1
4	A = 55 B = \varnothing 8	A = 65 B = \varnothing 8	A = 80 B = \varnothing 10	A = 90 B = \varnothing 12	1	
	Code	190.000.012	190.000.014	190.000.018		190.000.243
5	A = 50 B = \varnothing 8	A = 55 B = \varnothing 8	A = 70 B = \varnothing 10	A = 80 B = \varnothing 12	1	
	Code	190.000.011	190.000.012	190.000.016		190.000.271
8	A = 23.8 B = 76.5 C = 80 D = 21 E = 22 F = 29	A = 27 B = 88.2 C = 91.5 D = 24 E = 24 F = 36	A = 30.2 B = 98.4 C = 104 D = 24 E = 27 F = 45	A = 35 B = 109.3 C = 120 D = 24 E = 30 F = 54	1	
	Code	141.022.172.1	141.024.269.1	141.026.249.1		141.028.165.1

* Quantità presente nel cardano / Quantity in the PTO driveshaft

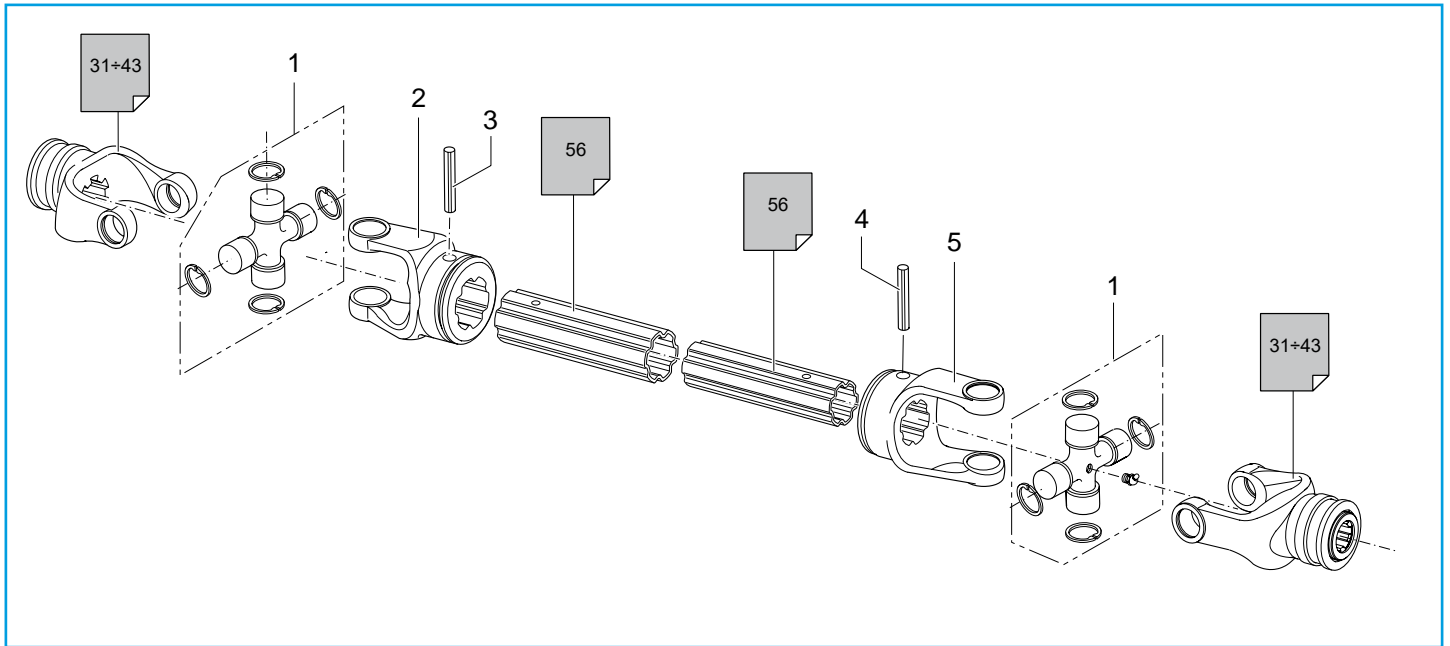
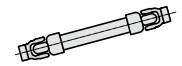

Pos.		
1	Crociera completa	Cross and bearing kit
2	Forcella per tubo esterno	Outer tube yoke
3	Spina elastica esterna	Outer roll pin
4	Spina elastica interna	Inner roll pin
5	Forcella per tubo interno	Inner tube yoke

Pos.	[mm]	Type						Qty*
		20	40	50	60	80	90	
1		A = \varnothing 23.8 B = 61.3	A = \varnothing 27 B = 74.6	A = \varnothing 30.2 B = 80	A = \varnothing 30.2 B = 92	A = \varnothing 35 B = 106.5	A = \varnothing 41 B = 108	2
	Code	180.012.004	180.014.004	180.015.004	180.016.004	180.018.004	180.019.043	
2		A = 23.8 B = 63.9 C = 80 D = 22 F = \varnothing 42	A = 27 B = 77.2 C = 91.5 D = 24 F = \varnothing 45.7	A = 30.2 B = 82.6 C = 97 D = 24 F = \varnothing 57.6	A = 30.2 B = 94.6 C = 104 D = 24 F = \varnothing 57.6	A = 35 B = 109.6 C = 120 D = 27 F = \varnothing 66.5	A = 41 B = 111.6 C = 124 D = 27 F = \varnothing 66.5	1
	Code	151.012.319.1	151.014.427.1	151.015.361.1	151.016.388.1	151.018.241.1	151.019.166.1	
3		A = 55 B = \varnothing 8	A = 65 B = \varnothing 8	A = 70 B = \varnothing 10	A = 80 B = \varnothing 10	A = 90 B = \varnothing 12	A = 90 B = \varnothing 12	1
	Code	190.000.012	190.000.014	190.000.016	190.000.018	190.000.243	190.000.243	
4		A = 50 B = \varnothing 8	A = 55 B = \varnothing 8	A = 65 B = \varnothing 10	A = 70 B = \varnothing 10	A = 80 B = \varnothing 12	A = 90 B = \varnothing 12	1
	Code	190.000.011	190.000.012	190.000.394	190.000.016	190.000.271	190.000.243	
5		A = 23.8 B = 63.9 C = 80 D = 21 F = \varnothing 36.2	A = 27 B = 77.2 C = 91.5 D = 24 F = \varnothing 39.3	A = 30.2 B = 82.6 C = 97 D = 24 F = \varnothing 50.2	A = 30.2 B = 94.6 C = 104 D = 24 F = \varnothing 50.2	A = 35 B = 109.6 C = 116 D = 24 F = \varnothing 58.1	A = 41 B = 111.6 C = 124 D = 27 F = \varnothing 58.1	1
	Code	151.012.320.1	151.014.428.1	151.015.362.1	151.016.389.1	151.018.242.1	151.019.167.1	

* Quantità presente nel cardano / Quantity in the PTO driveshaft

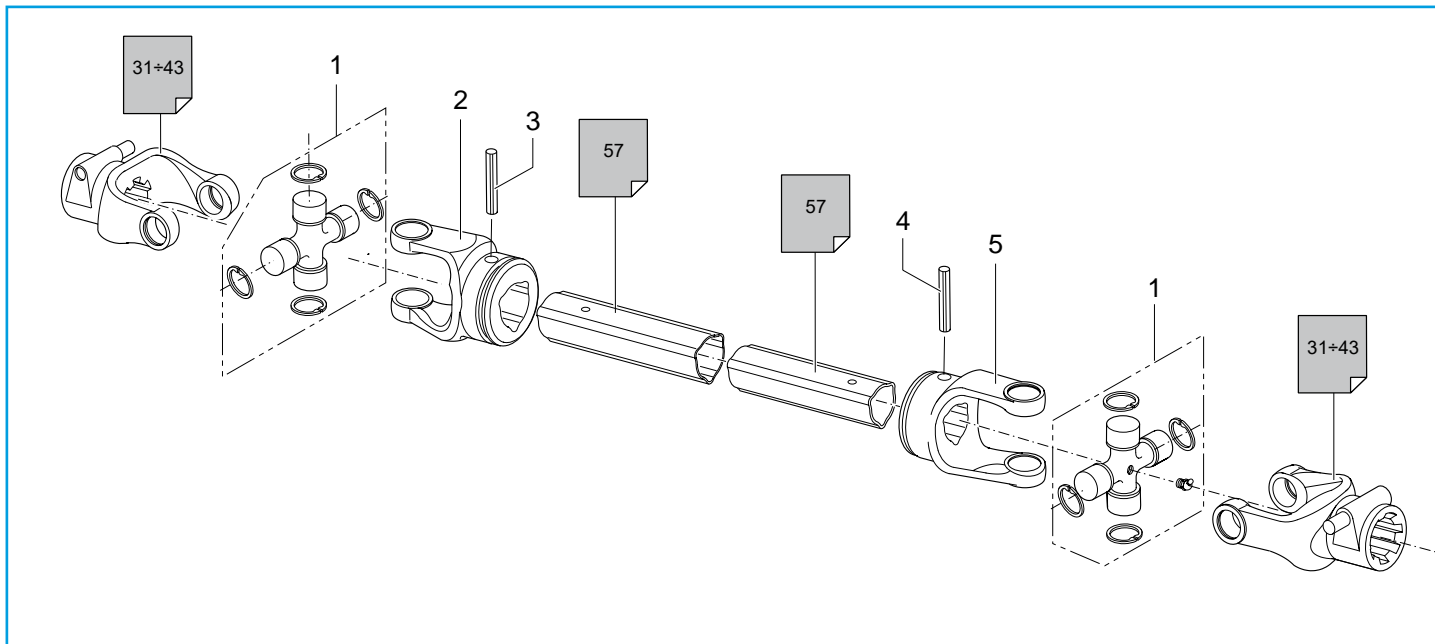
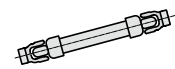

Pos.		
1	Crociera completa	Cross and bearing kit
2	Forcella per tubo esterno	Outer tube yoke
3	Spina elastica esterna	Outer roll pin
4	Spina elastica interna	Inner roll pin
5	Forcella per tubo interno	Inner tube yoke

Pos.	[mm]	Type							Qty*
		10	20	40	50	60	80	90	
1	[mm]	A = \varnothing 22 B = 54	A = \varnothing 23.8 B = 61.3	A = \varnothing 27 B = 74.6	A = \varnothing 30.2 B = 80	A = \varnothing 30.2 B = 92	A = \varnothing 35 B = 106.5	A = \varnothing 41 B = 108	2
	Code	180.011.130	180.012.130	180.014.130	180.015.130	180.016.130	180.018.130	180.019.130	
2	[mm]	A = 22 B = 56.2 C = 80 D = 22 F = 32.5	A = 23.8 B = 63.9 C = 80 D = 22 F = 36	A = 27 B = 77.2 C = 91.5 D = 24 F = 43.5	A = 30.2 B = 82.6 C = 97 D = 24 F = 51.6	A = 30.2 B = 94.6 C = 104 D = 24 F = 54	A = 35 B = 109.6 C = 120 D = 27 F = 63	A = 41 B = 111.6 C = 124 D = 27 F = 63	1
	Code	151.011.003.1	151.012.003.1	151.014.006.1	151.015.011.1	151.016.028.1	151.018.133.1	151.019.127.1	
3	[mm]	A = 50 B = \varnothing 8	A = 55 B = \varnothing 8	A = 65 B = \varnothing 8	A = 70 B = \varnothing 10	A = 80 B = \varnothing 10	A = 90 B = \varnothing 12	A = 90 B = \varnothing 12	1
	Code	190.000.011	190.000.012	190.000.014	190.000.016	190.000.018	190.000.243	190.000.243	
4	[mm]	A = 45 B = \varnothing 8	A = 50 B = \varnothing 8	A = 55 B = \varnothing 8	A = 65 B = \varnothing 10	A = 70 B = \varnothing 10	A = 80 B = \varnothing 12	A = 90 B = \varnothing 12	1
	Code	190.000.010	190.000.011	190.000.012	190.000.394	190.000.016	190.000.271	190.000.243	
5	[mm]	A = 22 B = 56.2 C = 80 D = 22 F = 26.5	A = 23.8 B = 63.9 C = 80 D = 21 F = 29	A = 27 B = 77.2 C = 91.5 D = 24 F = 36	A = 30.2 B = 82.6 C = 97 D = 24 F = 45	A = 30.2 B = 94.6 C = 104 D = 24 F = 45	A = 35 B = 109.6 C = 116 D = 24 F = 54	A = 41 B = 111.6 C = 124 D = 24 F = 54	1
	Code	151.011.002.1	151.012.002.1	151.014.007.1	151.015.012.1	151.016.029.1	151.018.134.1	151.019.128.1	

* Quantità presente nel cardano / Quantity in the PTO drivetrain

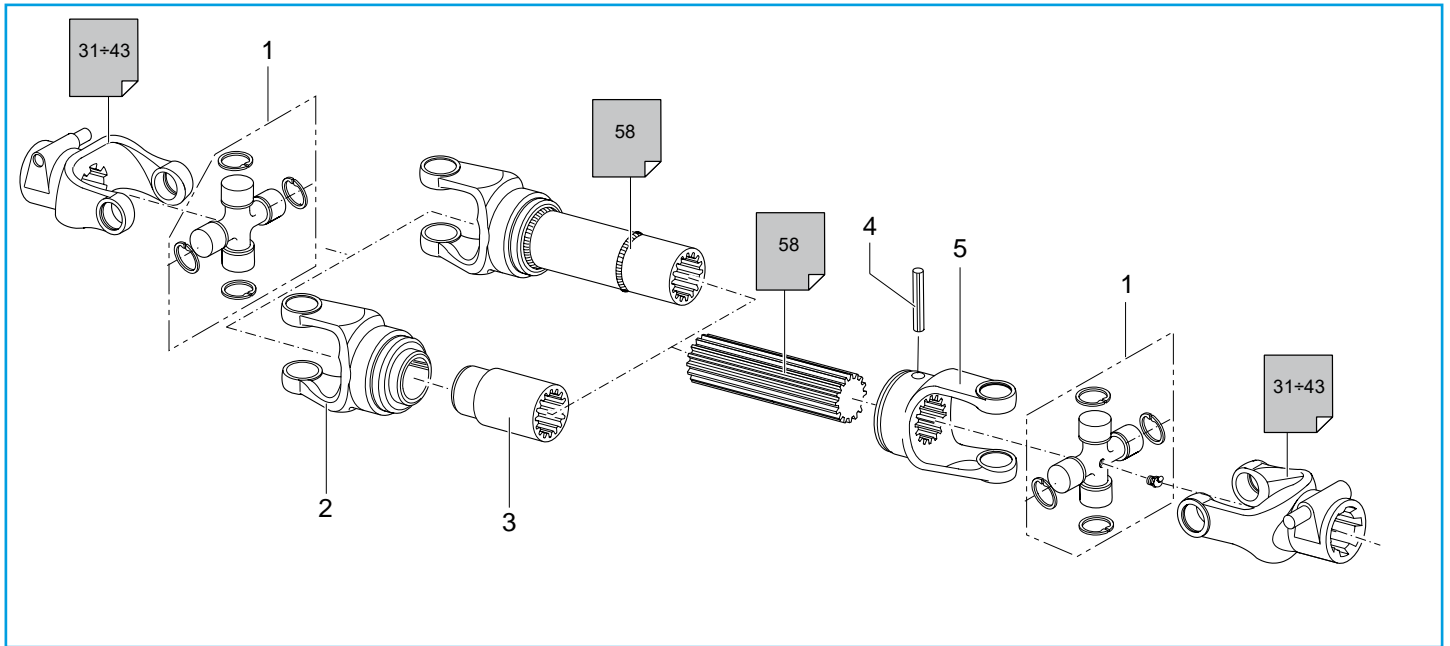
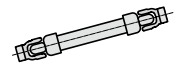

Pos.		
1	Crociera completa	Cross and bearing kit
2	Forcella per tubo esterno	Outer tube yoke
3	Bussola scanalata	Splined Sleeve
4	Spina elastica interna	Inner roll pin
5	Forcella per tubo interno	Inner tube yoke

Pos.	[mm]	Type					Qty*
		40	50	60	80	90	
1		A = \varnothing 27 B = 74.6	A = \varnothing 30.2 B = 80	A = \varnothing 30.2 B = 92	A = \varnothing 35 B = 106.5	A = \varnothing 41 B = 108	2
	Code	180.014.130	180.015.130	180.016.130	180.018.130	180.019.130	
2		A = 27 B = 77.2 C = 91.5 D = 42	A = 30.2 B = 82.6 C = 97 D = 42	A = 30.2 B = 94.6 C = 104 D = 42	A = 35 B = 109.6 C = 120 D = 50	A = 41 B = 111.6 C = 124 D = 52.5	1
	Code	151.014.003.1	151.015.003.1	151.016.035.1	151.018.144.1	151.019.055.1	
3		A = 30 CUNA Z10	A = 35 CUNA Z12	A = 35 CUNA Z12	A = 40 CUNA Z14	A = 45 CUNA Z16	1
	Code	151.014.249	151.016.032	151.016.032	151.018.014	151.019.056	
4		A = 55 B = \varnothing 8	A = 65 B = \varnothing 10	A = 70 B = \varnothing 10	A = 80 B = \varnothing 10	A = 90 B = \varnothing 12	1
	Code	190.000.012	190.000.394	190.000.016	190.000.018	190.000.243	
5		A = 27 B = 77.2 C = 91.5 D = 24 F = 30 CUNA	A = 30.2 B = 82.6 C = 97 D = 24 F = 35 CUNA	A = 30.2 B = 94.6 C = 104 D = 24 F = 35 CUNA	A = 35 B = 109.6 C = 116 D = 24 F = 40 CUNA	A = 41 B = 111.6 C = 124 D = 27 F = 45 CUNA	1
	Code	151.014.250.1	151.015.014.1	151.016.031.1	151.018.145.1	151.019.054.1	

* Quantità presente nel cardano / Quantity in the PTO driveshaft

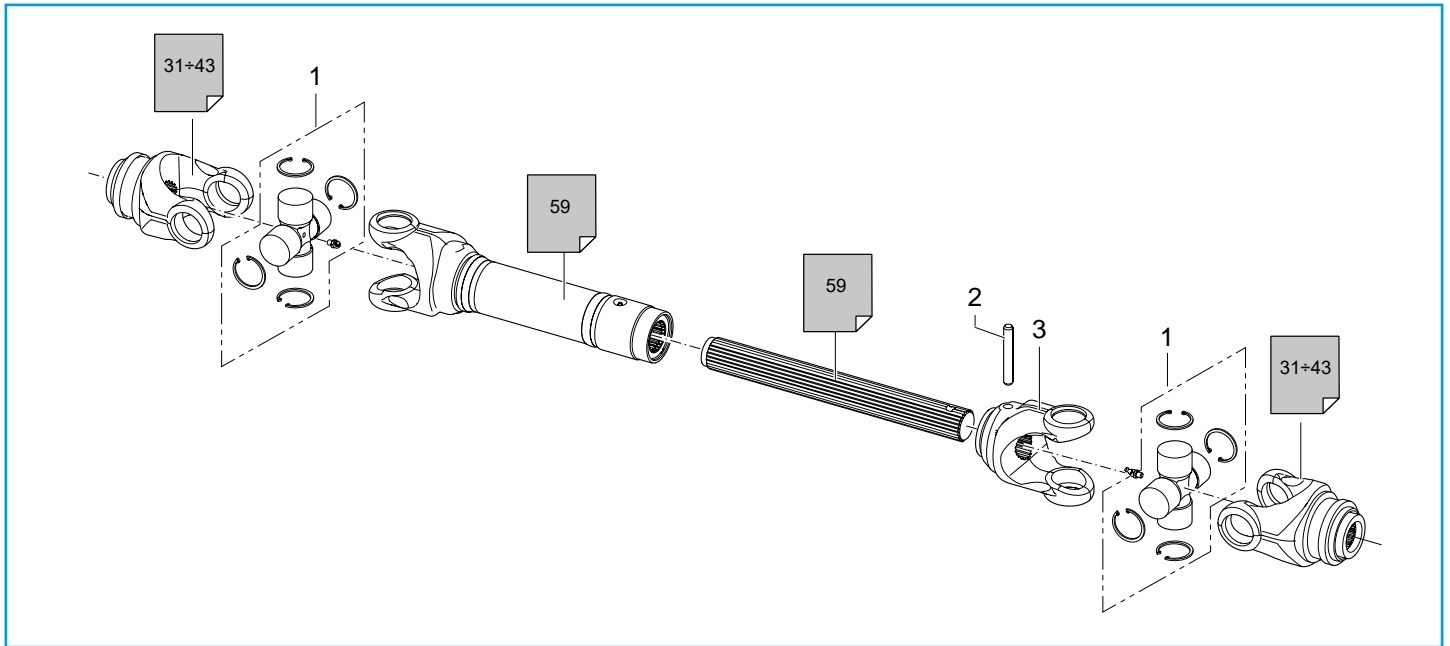
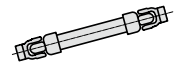

Pos.		
1	Crociera completa	Cross and bearing kit
2	Spina elastica interna	Inner roll pin
3	Forcella per tubo interno	Inner tube yoke

Pos.	[mm]	Type	Qty*
		120	
1	[mm]	A = \varnothing 52 B = 125	2
	Code	180.120.004	
2	[mm]	A = 100 B = \varnothing 14	1
	Code	190.000.698	
3	[mm]	A = 52 B = 130 C = 141 D = 36 F = DIN5482 A50x45 Z24	1
	Code	151.120.003.1	

* Quantità presente nel cardano / Quantity in the PTO driveshaft



Questa pagina è lasciata intenzionalmente bianca
This page is intentionally left blank

FORCELLE PER CARDANI OMOCINETICI CVJ E STANDARD YOKES FOR PTO DRIVESHAFTS CVJ AND STANDARD

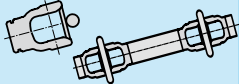
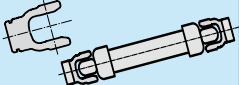
			p.
FORCELLE PER CARDANI OMOCINETICI CVJ YOKES FOR PTO DRIVESHAFTS CVJ			
Collar	<i>Collar</i>		28
Pulsante	<i>Push-pin</i>		29
Bullone interferente	<i>Interfering Clamp Bolt</i>		30
FORCELLE PER CARDANI STANDARD YOKES FOR PTO DRIVESHAFTS			
Collar	<i>Collar</i>		31
Pulsante	<i>Push-pin</i>		32
Calettata	<i>Splined</i>		33
Calettata bullone interferente	<i>Splined Interfering Clamp Bolt</i>		34
Calettata bullone interferente incassato	<i>Splined Interfering Recessed Clamp Bolt</i>		35
Calettata bullone non interferente	<i>Splined Not Interfering Clamp Bolt</i>		36
Foro liscio - chiavetta - bullone interferente	<i>Round Bore - Keyway - Interfering Clamp Bolt</i>		37
Foro liscio - chiavetta - bullone interferente incassato	<i>Round Bore - Keyway - Interfering Recessed Clamp Bolt</i>		38
Foro liscio - chiavetta - bullone non interferente	<i>Round Bore - Keyway - Not Interfering Clamp Bolt</i>		39
Foro liscio - chiavetta	<i>Round Bore - Keyway</i>		40
Foro liscio - chiavetta - foro spina	<i>Round Bore - Keyway - Pin Hole</i>		41
Foro liscio - foro spina	<i>Round Bore - Pin Hole</i>		42
Flangia C04	<i>Flange C04</i>		43
Flangia FGL	<i>Flange FGL</i>		43
Kit ricambi	<i>Spare Parts Kit</i>		44

**COLLAR
COLLAR**

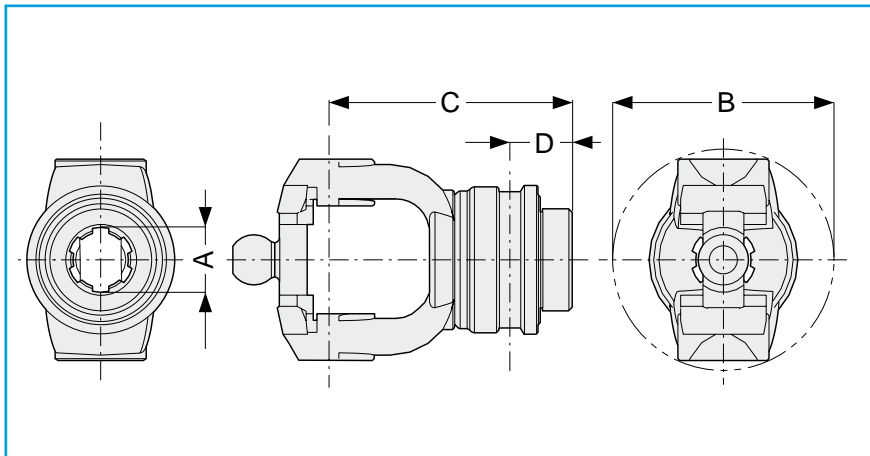
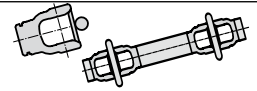

Type	Ref.	A	B		C		D		Code
			[mm]	[inch]	[mm]	[inch]	[mm]	[inch]	
20	C02	1 3/8" Z 6	94	3 45/64"	107	4 7/32"	26	1 1/32"	141.022.330.1
	C03	1 3/8" Z 21	94	3 45/64"	107	4 7/32"	26	1 1/32"	141.022.331.1
40	C02	1 3/8" Z 6	105	4 9/64"	115	4 17/32"	26	1 1/32"	141.024.439.1
	C03	1 3/8" Z 21	105	4 9/64"	115	4 17/32"	26	1 1/32"	141.024.441.1
60	C02	1 3/8" Z 6	117	4 39/64"	131	5 5/32"	38	1 31/64"	141.026.503.1
	C03	1 3/8" Z 21	117	4 39/64"	131	5 5/32"	38	1 31/64"	141.026.504.1
	C07	1 3/4" Z 6	117	4 39/64"	136	5 23/64"	38	1 31/64"	141.026.557.1
	C05	1 3/4" Z 20	117	4 39/64"	136	5 23/64"	38	1 31/64"	141.026.505.1
80	C02	1 3/8" Z 6	130	5 1/8"	136	5 23/64"	38	1 31/64"	141.028.358.1
	C03	1 3/8" Z 21	130	5 1/8"	136	5 23/64"	38	1 31/64"	141.028.359.1
	C07	1 3/4" Z 6	130	5 1/8"	138	5 7/16"	35.5	1 13/32"	141.028.361.1
	C05	1 3/4" Z 20	130	5 1/8"	138	5 7/16"	35.5	1 13/32"	141.028.360.1

**PULSANTE
PUSH-PIN**

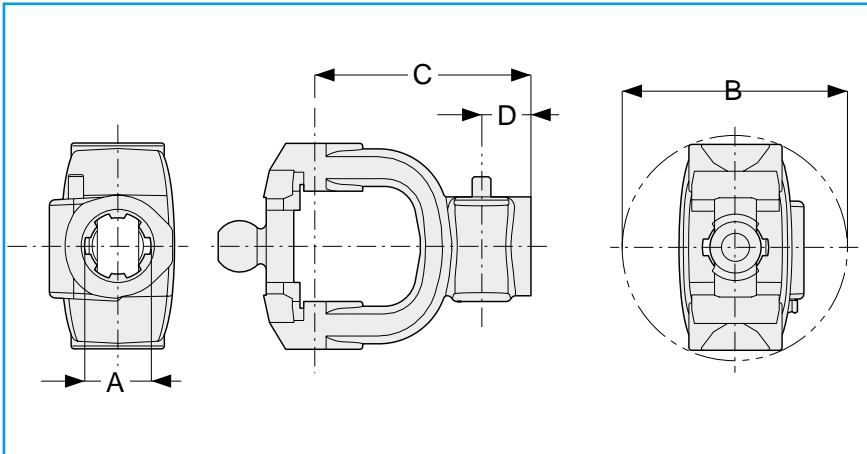
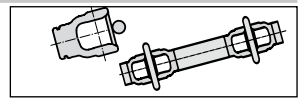

Forcelle per cardani
Yokes for PTO driveshafts

Type	Ref.	A	B		C		D		Code
			[mm]	[inch]	[mm]	[inch]	[mm]	[inch]	
20	112	1 3/8" Z 6	94	3 45/64"	99	3 57/64"	19	3/4"	141.022.162.1
	113	1 3/8" Z 21	94	3 45/64"	99	3 57/64"	19	3/4"	141.022.356.1
40	112	1 3/8" Z 6	105	4 9/64"	107	4 7/32"	19	3/4"	141.024.261.1
	113	1 3/8" Z 21	105	4 9/64"	107	4 7/32"	36	1 27/64"	141.024.272.1
60	112	1 3/8" Z 6	117	4 39/64"	113	4 29/64"	26	1 1/32"	141.026.230.1
	113	1 3/8" Z 21	117	4 39/64"	113	4 29/64"	36	1 27/64"	141.026.256.1
	114	1 3/4" Z 6	117	4 39/64"	114	4 31/64"	26	1 1/32"	141.026.266.1
	115	1 3/4" Z 20	117	4 39/64"	114	4 31/64"	26	1 1/32"	141.026.267.1
80	112	1 3/8" Z 6	130	5 1/8"	118	4 41/64"	26	1 1/32"	141.028.151.1
	113	1 3/8" Z 21	130	5 1/8"	118	4 41/64"	36	1 27/64"	141.028.177.1
	114	1 3/4" Z 6	130	5 1/8"	118	4 41/64"	26	1 1/32"	141.028.178.1
	115	1 3/4" Z 20	130	5 1/8"	118	4 41/64"	26	1 1/32"	141.028.170.1

BULLONE INTERFERENTE INTERFERING CLAMP SHAFT

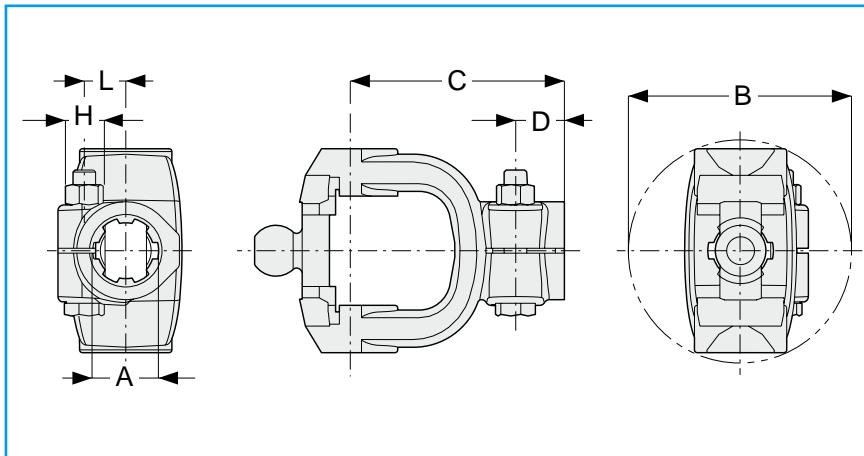
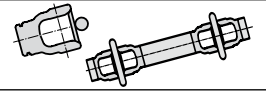

Type	Ref.	A		B		C		D		H		L		Code
		[mm]	[inch]	[mm]	[inch]	[mm]	[inch]	[mm]	[inch]	M...x...cl.8.8	Qty	[mm]	[inch]	
20	132	1 3/8"	Z 6	94	3 45/64"	99	3 57/64"	19	3/4"	M12x1.25x65	1	21.0	53/64"	141.022.359.1
	133	1 3/8"	Z 21	94	3 45/64"	99	3 57/64"	19	3/4"	M12x1.25x65	1	21.0	53/64"	141.022.360.1
40	132	1 3/8"	Z 6	105	4 9/64"	107	4 7/32"	19	3/4"	M12x1.25x65	1	21.0	53/64"	141.024.436.1
	133	1 3/8"	Z 21	105	4 9/64"	107	4 7/32"	36	1 27/64"	M12x1.25x65	1	21.0	53/64"	141.024.474.1
60	132	1 3/8"	Z 6	117	4 39/64"	113	4 29/64"	26	1 1/32"	M12x1.25x65	1	21.0	53/64"	141.026.532.1
	133	1 3/8"	Z 21	117	4 39/64"	113	4 29/64"	36	1 27/64"	M12x1.25x65	1	21.0	53/64"	141.026.533.1
	134	1 3/4"	Z 6	117	4 39/64"	114	4.31/64"	26	1 1/32"	M16x80	1	27.2	5/64"	141.026.620.1
80	135	1 3/4"	Z 20	117	4 39/64"	114	4.31/64"	26	1 1/32"	M16x80	1	27.2	5/64"	141.026.534.1
	132	1 3/8"	Z 6	130	5 1/8"	118	4 41/64"	26	1 1/32"	M12x1.25x65	2	21.0	53/64"	141.028.476.1
	133	1 3/8"	Z 21	130	5 1/8"	118	4 41/64"	36	1 27/64"	M12x1.25x65	2	21.0	53/64"	141.028.475.1
	134	1 3/4"	Z 6	130	5 1/8"	118	4 41/64"	26	1 1/32"	M16x80	2	27.2	5/64"	141.028.480.1
	135	1 3/4"	Z 20	130	5 1/8"	118	4 41/64"	26	1 1/32"	M16x80	2	27.2	5/64"	141.028.481.1

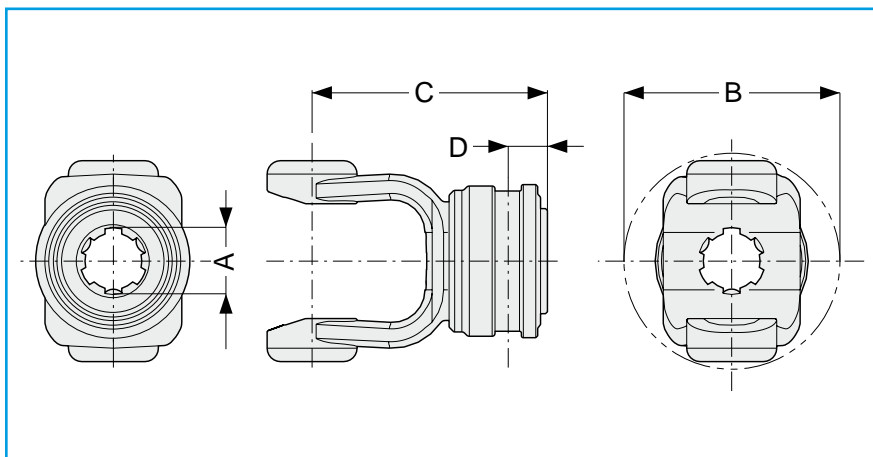
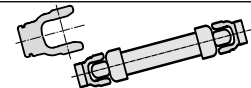

Forcelle per cardani
Yokes for PTO driveshafts

Type	Ref.	A	B		C		D		Code
			[mm]	[inch]	[mm]	[inch]	[mm]	[inch]	
10	C12	1 3/8" Z 6	73	2 7/8"	102	4.02"	26	1 1/32"	141.021.319.1
	C13	1 3/8" Z 21	73	2 7/8"	102	4.02"	26	1 1/32"	141.021.320.1
20	C12	1 3/8" Z 6	80	3 5/32"	109	4 19/64"	26	1 1/32"	141.022.324.1
	C13	1 3/8" Z 21	80	3 5/32"	109	4 19/64"	26	1 1/32"	141.022.327.1
40	C12	1 3/8" Z 6	94	3 45/64"	111	4 3/8"	26	1 1/32"	141.024.430.1
	C13	1 3/8" Z 21	94	3 45/64"	111	4 3/8"	26	1 1/32"	141.024.437.1
50	C12	1 3/8" Z 6	100	3 15/16"	117	4 39/64"	26	1 1/32"	141.025.363.1
	C13	1 3/8" Z 21	100	3 15/16"	117	4 39/64"	26	1 1/32"	141.025.364.1
60	C12	1 3/8" Z 6	115	4 17/32"	123	4 27/32"	26	1 1/32"	141.026.544.1
	C13	1 3/8" Z 21	115	4 17/32"	123	4 27/32"	26	1 1/32"	141.026.553.1
	C17	1 3/4" Z 6	115	4 17/32"	131	5 5/32"	29.5	1 5/32"	141.026.554.1
	C15	1 3/4" Z 20	115	4 17/32"	131	5 5/32"	29.5	1 5/32"	141.026.555.1
80	C12	1 3/8" Z 6	132	5 13/64"	137	5 25/64"	26	1 1/32"	141.028.423.1
	C13	1 3/8" Z 21	132	5 13/64"	137	5 25/64"	26	1 1/32"	141.028.426.1
	C17	1 3/4" Z 6	132	5 13/64"	142	5 19/32"	29.5	1 5/32"	141.028.427.1
	C15	1 3/4" Z 20	132	5 13/64"	142	5 19/32"	29.5	1 5/32"	141.028.428.1
90	C12	1 3/8" Z 6	137	5 25/64"	144	5 43/64"	26	1 1/32"	141.029.319.1
	C13	1 3/8" Z 21	137	5 25/64"	144	5 43/64"	26	1 1/32"	141.029.320.1
	C17	1 3/4" Z 6	137	5 25/64"	152	5 63/64"	29.5	1 5/32"	141.029.317.1
	C15	1 3/4" Z 20	137	5 25/64"	152	5 63/64"	29.5	1 5/32"	141.029.318.1
120	C27	1 3/4" Z 6	155	6 7/64"	162	6 3/8"	45.5	1 51/64"	141.220.005.1
	C25	1 3/4" Z 20	155	6 7/64"	162	6 3/8"	45.5	1 51/64"	141.220.001.1

**PULSANTE
PUSH-PIN**

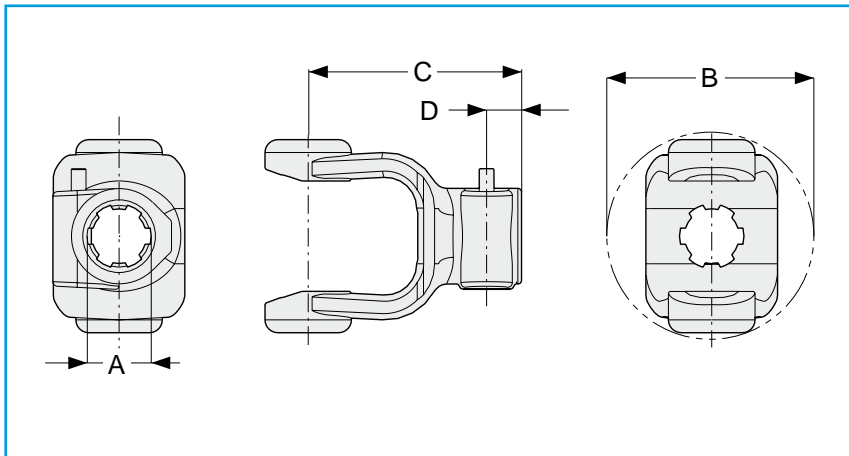
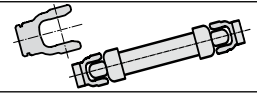

Type	Ref.	A	B		C		D		Code
			[mm]	[inch]	[mm]	[inch]	[mm]	[inch]	
10	112	1 3/8" Z 6	73	2 7/8"	90	3 35/64"	19	3/4"	141.021.001.1
	113	1 3/8" Z 21	73	2 7/8"	90	3 35/64"	19	3/4"	141.021.002.1
	PZ8	32 UNI 221	73	2 7/8"	90	3 35/64"	19	3/4"	141.021.264.1
20	112	1 3/8" Z 6	80	3 5/32"	99	3 57/64"	19	3/4"	141.022.001.1
	113	1 3/8" Z 21	80	3 5/32"	99	3 57/64"	19	3/4"	141.022.002.1
	PZ8	32 UNI 221	80	3 5/32"	99	3 57/64"	19	3/4"	141.022.449.1
40	112	1 3/8" Z 6	94	3 45/64"	107	4 7/32"	19	3/4"	141.024.001.1
	113	1 3/8" Z 21	94	3 45/64"	107	4 7/32"	19	3/4"	141.024.002.1
	PZ8	32 UNI 221	94	3 45/64"	107	4 7/32"	19	3/4"	141.024.266.1
50	112	1 3/8" Z 6	100	3 15/16"	109	4 19/64"	19	3/4"	141.025.001.1
	113	1 3/8" Z 21	100	3 15/16"	109	4 19/64"	19	3/4"	141.025.002.1
	PZ8	32 UNI 221	100	3 15/16"	109	4 19/64"	19	3/4"	141.025.414.1
60	112	1 3/8" Z 6	115	4 17/32"	116	4 9/16"	19	3/4"	141.026.001.1
	113	1 3/8" Z 21	115	4 17/32"	116	4 9/16"	19	3/4"	141.026.002.1
	PZ8	32 UNI 221	115	4 17/32"	116	4 9/16"	19	3/4"	141.026.199.1
	114	1 3/4" Z 6	115	4 17/32"	124	4 7/8"	24	7/8"	141.026.003.1
	115	1 3/4" Z 20	115	4 17/32"	124	4 7/8"	24	7/8"	141.026.008.1
80	112	1 3/8" Z 6	132	5 13/64"	124	4 7/8"	19	3/4"	141.028.001.1
	113	1 3/8" Z 21	132	5 13/64"	124	4 7/8"	19	3/4"	141.028.002.1
	PZ8	32 UNI 221	132	5 13/64"	124	4 7/8"	19	3/4"	141.028.146.1
	114	1 3/4" Z 6	132	5 13/64"	128	5 3/64"	24	7/8"	141.028.003.1
	115	1 3/4" Z 20	132	5 13/64"	128	5 3/64"	24	7/8"	141.028.004.1
90	112	1 3/8" Z 6	137	5 25/64"	133	5 15/64"	24	7/8"	141.029.039.1
	113	1 3/8" Z 21	137	5 25/64"	133	5 15/64"	24	7/8"	141.029.040.1
	PZ8	32 UNI 221	137	5 25/64"	133	5 15/64"	24	7/8"	141.029.373.1
	114	1 3/4" Z 6	137	5 25/64"	133	5 15/64"	24	7/8"	141.029.057.1
	115	1 3/4" Z 20	137	5 25/64"	133	5 15/64"	24	7/8"	141.029.058.1

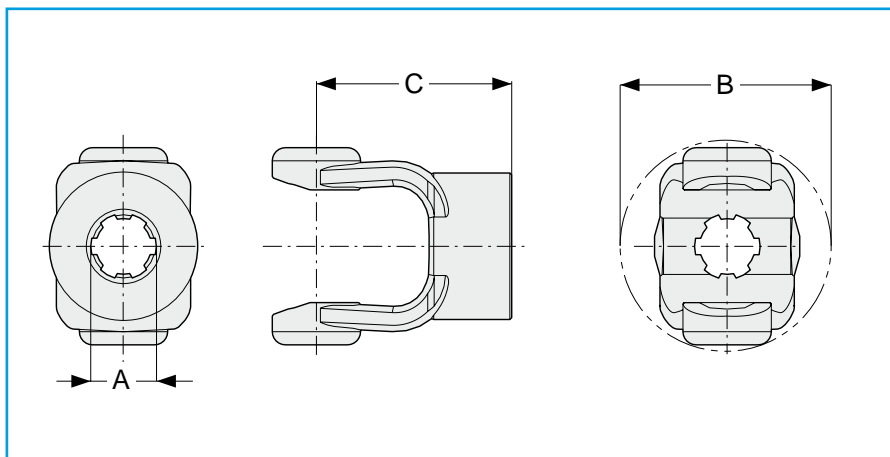
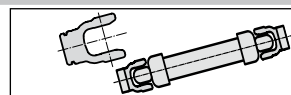

Forcelle per cardani
Yokes for PTO driveshafts

Type	Ref.	A	B		C		Code
			[mm]	[inch]	[mm]	[inch]	
10	122	1 3/8" Z 6	73	2 7/8"	80	3 5/32"	151.011.054.1
	123	1 3/8" Z 21	73	2 7/8"	80	3 5/32"	151.011.055.1
20	122	1 3/8" Z 6	80	3 5/32"	80	3 5/32"	151.012.049.1
	123	1 3/8" Z 21	80	3 5/32"	80	3 5/32"	151.012.050.1
40	122	1 3/8" Z 6	94	3 45/64"	91.5	3 39/64"	151.014.057.1
	123	1 3/8" Z 21	94	3 45/64"	91.5	3 39/64"	151.014.058.1
50	122	1 3/8" Z 6	100	3 15/16"	97	3 13/16"	151.015.061.1
	123	1 3/8" Z 21	100	3 15/16"	97	3 13/16"	151.015.062.1
60	122	1 3/8" Z 6	115	4 17/32"	104	4 3/32"	151.016.064.1
	123	1 3/8" Z 21	115	4 17/32"	104	4 3/32"	151.016.080.1
	124	1 3/4" Z 6	115	4 17/32"	104	4 3/32"	151.016.081.1
	125	1 3/4" Z 20	115	4 17/32"	104	4 3/32"	151.016.082.1
80	122	1 3/8" Z 6	132	5 13/64"	116	4 9/16"	151.018.045.1
	123	1 3/8" Z 21	132	5 13/64"	116	4 9/16"	151.018.062.1
	124	1 3/4" Z 6	132	5 13/64"	116	4 9/16"	151.018.063.1
	125	1 3/4" Z 20	132	5 13/64"	116	4 9/16"	151.018.064.1
90	122	1 3/8" Z 6	137	5 25/64"	124	4 7/8"	151.019.064.1
	123	1 3/8" Z 21	137	5 25/64"	124	4 7/8"	151.019.065.1
	124	1 3/4" Z 6	137	5 25/64"	124	4 7/8"	151.019.066.1
	125	1 3/4" Z 20	137	5 25/64"	124	4 7/8"	151.019.067.1

CALETTATA - BULLONE INTERFERENTE SPLINED - INTERFERING CLAMP BOLT

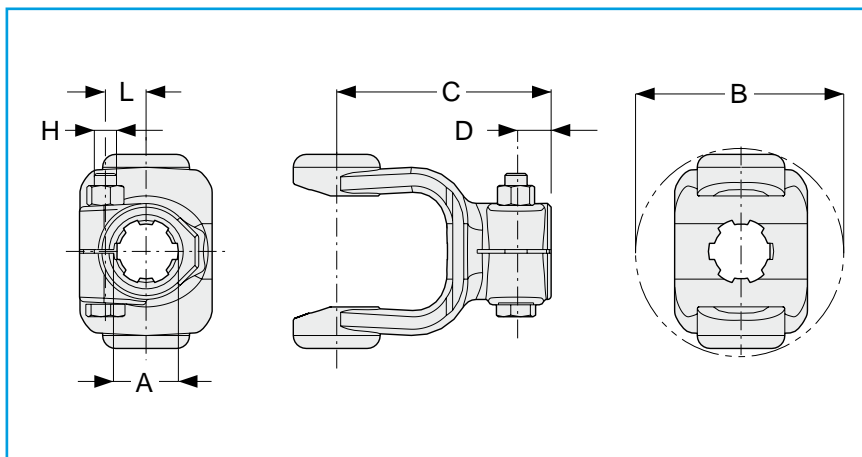
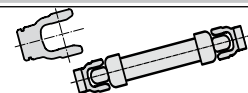

Type	Ref.	A		B		C		D		H		L		Code
		[mm]	[inch]	[mm]	[inch]	[mm]	[inch]	[mm]	[inch]	M...cl.8.8	Qty	[mm]	[inch]	
10	132	1 3/8"	Z 6	73	2 7/8"	90	3 35/64"	19	3/4"	M12x1.25x65	1	21	53/64"	141.021.056.1
	133	1 3/8"	Z 21	73	2 7/8"	90	3 35/64"	19	3/4"	M12x1.25x65	1	21	53/64"	141.021.057.1
20	132	1 3/8"	Z 6	80	3 5/32"	99	3 57/64"	19	3/4"	M12x1.25x65	1	21	53/64"	141.022.008.1
	133	1 3/8"	Z 21	80	3 5/32"	99	3 57/64"	19	3/4"	M12x1.25x65	1	21	53/64"	141.022.051.1
40	132	1 3/8"	Z 6	94	3 45/64"	107	4 7/32"	19	3/4"	M12x1.25x65	1	21	53/64"	141.024.014.1
	133	1 3/8"	Z 21	94	3 45/64"	107	4 7/32"	19	3/4"	M12x1.25x65	1	21	53/64"	141.024.059.1
50	132	1 3/8"	Z 6	100	3 15/16"	109	4 19/64"	19	3/4"	M12x1.25x65	1	21	53/64"	141.025.027.1
	133	1 3/8"	Z 21	100	3 15/16"	109	4 19/64"	19	3/4"	M12x1.25x65	2	21	53/64"	141.025.063.1
60	132	1 3/8"	Z 6	115	4 17/32"	116	4 9/16"	19	3/4"	M12x1.25x65	1	21	53/64"	141.026.047.1
	133	1 3/8"	Z 21	115	4 17/32"	116	4 9/16"	19	3/4"	M12x1.25x65	2	21	53/64"	141.026.048.1
	134	1 3/4"	Z 6	115	4 17/32"	124	4 7/8"	24	7/8"	M16x80	1	27.2	1 5/64"	141.026.049.1
	135	1 3/4"	Z 20	115	4 17/32"	124	4 7/8"	24	7/8"	M16x80	1	27.2	1 5/64"	141.026.083.1
80	132	1 3/8"	Z 6	132	5 13/64"	124	4 7/8"	19	3/4"	M12x1.25x65	2	21	53/64"	141.028.028.1
	133	1 3/8"	Z 21	132	5 13/64"	124	4 7/8"	19	3/4"	M12x1.25x65	2	21	53/64"	141.028.029.1
	134	1 3/4"	Z 6	132	5 13/64"	128	5 3/64"	24	7/8"	M16x80	2	27.2	1 5/64"	141.028.030.1
	135	1 3/4"	Z 20	132	5 13/64"	128	5 3/64"	24	7/8"	M16x80	2	27.2	1 5/64"	141.028.065.1
90	132	1 3/8"	Z 6	137	5 25/64"	133	5 15/64"	24	7/8"	M14x1.5x80	2	22	55/64"	141.029.022.1
	133	1 3/8"	Z 21	137	5 25/64"	133	5 15/64"	24	7/8"	M14x1.5x80	2	22	55/64"	141.029.023.1
	134	1 3/4"	Z 6	137	5 25/64"	133	5 15/64"	24	7/8"	M16x80	2	27.2	1 5/64"	141.029.024.1
	135	1 3/4"	Z 20	137	5 25/64"	133	5 15/64"	24	7/8"	M16x80	2	27.2	1 5/64"	141.029.068.1
120	134	1 3/4"	Z 6	155	6 7/64"	168	3 39/64"	45.5	1 51/64"	M16x90	2	27.2	1 5/64"	141.220.035.1
	135	1 3/4"	Z 20	155	6 7/64"	168	3 39/64"	45.5	1 51/64"	M16x90	2	27.2	1 5/64"	141.220.038.1

CALETTATA - BULLONE INTERFERENTE INCASSATO
SPLINED - INTERFERING RECESSED CLAMP BOLT

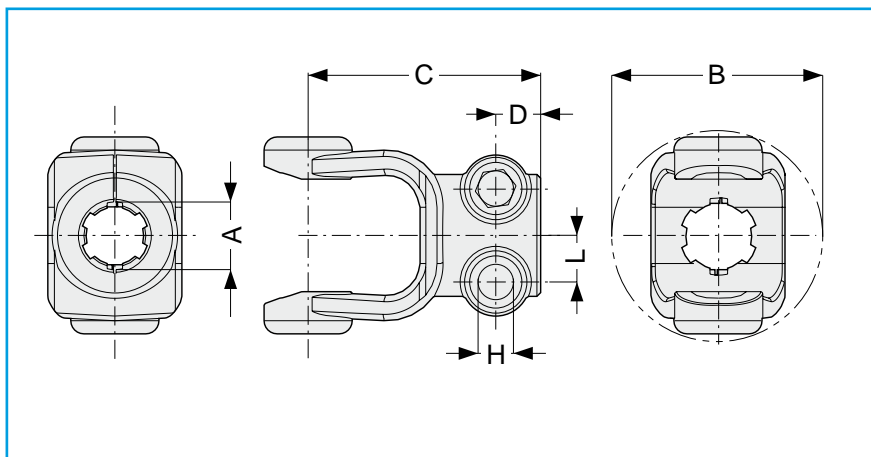
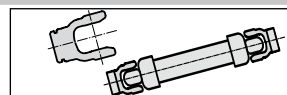

Forcelle per cardani
Yokes for PTO driveshafts

Type	Ref.	A		B		C		D		H		L		Code
		[mm]	[inch]	[mm]	[inch]	[mm]	[inch]	[mm]	[inch]	M...cl.8.8	Qty	[mm]	[inch]	
10	162	1 3/8"	Z 6	104	4 3/32"	101	3 31/32"	24	15/16"	M12x1.25x55	1	21	53/64"	141.021.333.1
	163	1 3/8"	Z 21	104	4 3/32"	101	3 31/32"	24	15/16"	M12x1.25x55	1	21	53/64"	141.021.334.1
20	162	1 3/8"	Z 6	104	4 3/32"	104	4 3/32"	24	15/16"	M12x1.25x55	1	21	53/64"	141.022.361.1
	163	1 3/8"	Z 21	104	4 3/32"	104	4 3/32"	24	15/16"	M12x1.25x55	1	21	53/64"	141.022.362.1
40	162	1 3/8"	Z 6	104	4 3/32"	113	4 29/64"	24	15/16"	M12x1.25x55	1	21	53/64"	141.024.475.1
	163	1 3/8"	Z 21	104	4 3/32"	113	4 29/64"	24	15/16"	M12x1.25x55	1	21	53/64"	141.024.476.1
50	162	1 3/8"	Z 6	110	4 21/64"	116	4 9/16"	24	15/16"	M12x1.25x55	2	21	53/64"	141.025.379.1
	163	1 3/8"	Z 21	110	4 21/64"	116	4 9/16"	24	15/16"	M12x1.25x55	2	21	53/64"	141.025.380.1
	164	1 3/4"	Z 6	110	4 21/64"	116	4 9/16"	24	15/16"	M12x1.25x55	2	25	63/64"	141.025.381.1
	165	1 3/4"	Z 20	110	4 21/64"	116	4 9/16"	24	15/16"	M12x1.25x55	2	25	63/64"	141.025.346.1
60	162	1 3/8"	Z 6	115	4 17/32"	124	4 7/8"	24	15/16"	M12x1.25x55	2	21	53/64"	141.026.621.1
	163	1 3/8"	Z 21	115	4 17/32"	124	4 7/8"	24	15/16"	M12x1.25x55	2	21	53/64"	141.026.459.1
	164	1 3/4"	Z 6	115	4 17/32"	124	4 7/8"	24	15/16"	M12x1.25x55	2	25	63/64"	141.026.622.1
	165	1 3/4"	Z 20	115	4 17/32"	124	4 7/8"	24	15/16"	M12x1.25x55	2	25	63/64"	141.026.374.1
80	162	1 3/8"	Z 6	132	5 13/64"	128	5 3/64"	24	15/16"	M12x1.25x55	2	21	53/64"	141.028.339.1
	163	1 3/8"	Z 21	132	5 13/64"	128	5 3/64"	24	15/16"	M12x1.25x55	2	21	53/64"	141.028.340.1
	164	1 3/4"	Z 6	132	5 13/64"	128	5 3/64"	24	15/16"	M12x1.25x55	2	25	63/64"	141.028.482.1
	165	1 3/4"	Z 20	132	5 13/64"	128	5 3/64"	24	15/16"	M12x1.25x55	2	25	63/64"	141.028.301.1
90	162	1 3/8"	Z 6	137	5 25/64"	136	5 23/64"	24	15/16"	M12x1.25x55	2	21	53/64"	141.029.342.1
	163	1 3/8"	Z 21	137	5 25/64"	136	5 23/64"	24	15/16"	M12x1.25x55	2	21	53/64"	141.029.343.1
	164	1 3/4"	Z 6	137	5 25/64"	136	5 23/64"	24	15/16"	M12x1.25x55	2	25	63/64"	141.029.344.1
	165	1 3/4"	Z 20	137	5 25/64"	136	5 23/64"	24	15/16"	M12x1.25x55	2	25	63/64"	141.029.345.1

CALETTATA - BULLONE NON INTERFERENTE
SPLINED - NOT INTERFERING CLAMP BOLT

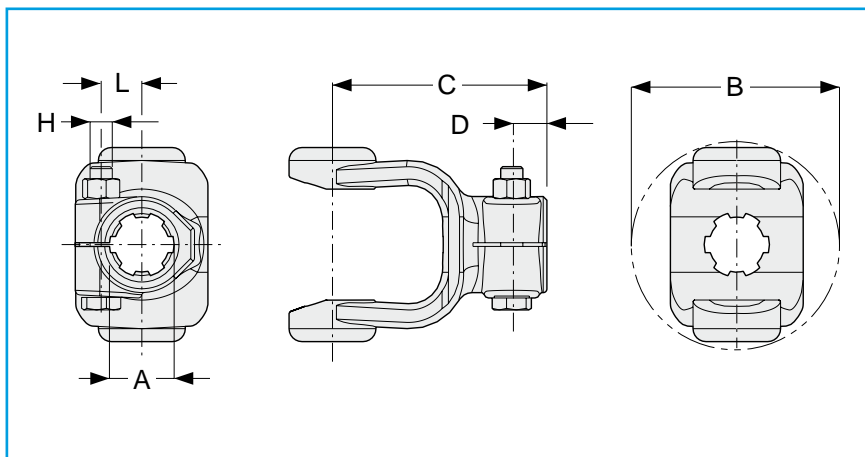
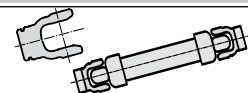

Type	Ref.	A		B		C		D		H		L		Code
		[mm]	[inch]	[mm]	[inch]	[mm]	[inch]	[mm]	[inch]	M..x..cl.8.8	Qty	[mm]	[inch]	
10	142	1 3/8"	Z 6	73	2 7/8"	90	3 55/64"	19	3/4"	M10x1.25x65	1	23.5	59/64"	141.021.059.1
	143	1 3/8"	Z 21	73	2 7/8"	90	3 55/64"	19	3/4"	M10x1.25x65	1	23.5	59/64"	141.021.060.1
20	142	1 3/8"	Z 6	80	3 5/32"	99	3 57/64"	19	3/4"	M10x1.25x65	1	23.5	59/64"	141.022.052.1
	143	1 3/8"	Z 21	80	3 5/32"	99	3 57/64"	19	3/4"	M10x1.25x65	1	23.5	59/64"	141.022.053.1
40	142	1 3/8"	Z 6	94	3 45/64"	107	4 7/32"	19	3/4"	M10x1.25x65	1	23.5	59/64"	141.024.060.1
	143	1 3/8"	Z 21	94	3 45/64"	107	4 7/32"	19	3/4"	M10x1.25x65	1	23.5	59/64"	141.024.061.1
50	142	1 3/8"	Z 6	100	3 15/16"	109	4 19/64"	19	3/4"	M10x1.25x65	1	23.5	59/64"	141.025.064.1
	143	1 3/8"	Z 21	100	3 15/16"	109	4 19/64"	19	3/4"	M10x1.25x65	2	23.5	59/64"	141.025.065.1
60	142	1 3/8"	Z 6	115	4 17/32"	116	4 9/16"	19	3/4"	M10x1.25x65	1	23.5	59/64"	141.026.084.1
	143	1 3/8"	Z 21	115	4 17/32"	116	4 9/16"	19	3/4"	M10x1.25x65	2	23.5	59/64"	141.026.085.1
	144	1 3/4"	Z 6	115	4 17/32"	124	4 7/8"	24	7/8"	M12x1.25x80	1	29.5	1 1/32"	141.026.086.1
	145	1 3/4"	Z 20	115	4 17/32"	124	4 7/8"	24	7/8"	M12x1.25x80	1	29.5	1 1/32"	141.026.087.1
80	142	1 3/8"	Z 6	132	5 13/64"	124	4 7/8"	19	3/4"	M10x1.25x65	2	23.5	59/64"	141.028.066.1
	143	1 3/8"	Z 21	132	5 13/64"	124	4 7/8"	19	3/4"	M10x1.25x65	2	23.5	59/64"	141.028.067.1
	144	1 3/4"	Z 6	132	5 13/64"	128	5 3/64"	24	7/8"	M12x1.25x80	2	29.5	1 1/32"	141.028.068.1
	145	1 3/4"	Z 20	132	5 13/64"	128	5 3/64"	24	7/8"	M12x1.25x80	2	29.5	1 1/32"	141.028.069.1
90	142	1 3/8"	Z 6	137	5 25/64"	133	5 15/64"	24	7/8"	M14x1.5x80	2	25.5	1"	141.029.069.1
	143	1 3/8"	Z 21	137	5 25/64"	133	5 15/64"	24	7/8"	M14x1.5x80	2	25.5	1"	141.029.070.1
	144	1 3/4"	Z 6	137	5 25/64"	133	5 15/64"	24	7/8"	M12x1.25x65	2	29.5	1 1/32"	141.029.071.1
	145	1 3/4"	Z 20	137	5 25/64"	133	5 15/64"	24	7/8"	M12x1.25x65	2	29.5	1 1/32"	141.029.072.1

FORO LISCIO - CHIAVETTA - BULLONE INTERFERENTE
ROUND BORE - KEYWAY - INTERFERING CLAMP BOLT

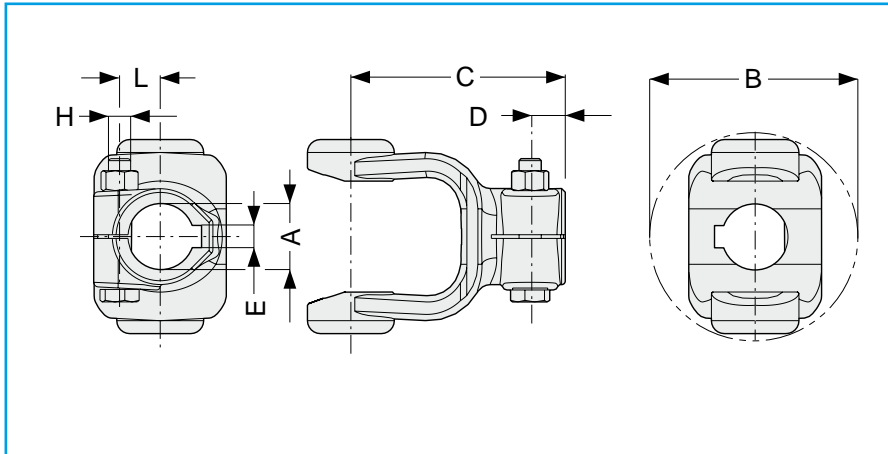
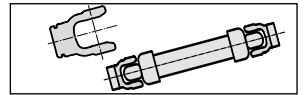

Forcelle per cardani
Yokes for PTO driveshafts

Type	Ref.	A		B		C		D		E		H		L		Code
		[mm]	[inch]	[mm]	[inch]	[mm]	[inch]	[mm]	[inch]	M...x.cl.8.8	Qty	[mm]	[inch]			
10	331	20	73	2 7/8"	90	3 35/64"	19	3/4"	6	M10x1.25x65	1	13.5	17/32"	141.021.071.1		
	332	25	73	2 7/8"	90	3 35/64"	19	3/4"	8	M10x1.25x65	1	16	5/8"	141.021.072.1		
	333	30	73	2 7/8"	90	3 35/64"	19	3/4"	8	M12x1.25x65	1	19	3/4"	141.021.073.1		
	431	3/4"	73	2 7/8"	90	3 35/64"	19	3/4"	3/16"	M10x1.25x65	1	12.5	17/32"	141.021.074.1		
	432	1"	73	2 7/8"	90	3 35/64"	19	3/4"	1/4"	M10x1.25x65	1	16	5/8"	141.021.075.1		
20	331	20	80	3 5/32"	99	3 57/64"	19	3/4"	6	M10x1.25x65	1	13.5	17/32"	141.022.066.1		
	332	25	80	3 5/32"	99	3 57/64"	19	3/4"	8	M10x1.25x65	1	16	5/8"	141.022.067.1		
	333	30	80	3 5/32"	99	3 57/64"	19	3/4"	8	M12x1.25x65	1	19	3/4"	141.022.068.1		
	431	3/4"	80	3 5/32"	99	3 57/64"	19	3/4"	3/16"	M10x1.25x65	1	12.5	17/32"	141.022.069.1		
	432	1"	80	3 5/32"	99	3 57/64"	19	3/4"	1/4"	M10x1.25x65	1	16	5/8"	141.022.070.1		
	433	1 1/4"	80	3 5/32"	99	3 57/64"	19	3/4"	5/16"	M12x1.25x65	1	19	3/4"	141.022.108.1		
40	332	25	94	3 45/64"	107	4 7/32"	19	3/4"	8	M10x1.25x65	1	16	5/8"	141.024.072.1		
	333	30	94	3 45/64"	107	4 7/32"	19	3/4"	8	M12x1.25x65	1	19	3/4"	141.024.073.1		
	334	35	94	3 45/64"	107	4 7/32"	19	3/4"	10	M12x1.25x65	1	21.5	27/32"	141.024.074.1		
	433	1 1/4"	94	3 45/64"	107	4 7/32"	19	3/4"	5/16"	M12x1.25x65	1	19	3/4"	141.024.076.1		
	434	1 3/8"	94	3 45/64"	107	4 7/32"	19	3/4"	5/16"	M12x1.25x65	1	21.5	27/32"	141.024.077.1		
50	333	30	100	3 5/16"	109	4 19/64"	19	3/4"	8	M12x1.25x65	1	19	3/4"	141.025.076.1		
	334	35	100	3 5/16"	109	4 19/64"	19	3/4"	10	M12x1.25x65	1	21.5	27/32"	141.025.164.1		
	433	1 1/4"	100	3 5/16"	109	4 19/64"	19	3/4"	5/16"	M12x1.25x65	1	19	3/4"	141.025.079.1		
	434	1 3/8"	100	3 5/16"	109	4 19/64"	19	3/4"	5/16"	M12x1.25x65	1	21.5	27/32"	141.025.080.1		
60	333	30	115	4 17/32"	116	4 9/16"	19	3/4"	8	M12x1.25x65	1	19	3/4"	141.026.100.1		
	334	35	115	4 17/32"	116	4 9/16"	19	3/4"	10	M12x1.25x65	1	21.5	27/32"	141.026.101.1		
	335	40	115	4 17/32"	124	4 7/8"	24	7/8"	12	M12x1.25x75	1	24	7/8"	141.026.102.1		
	433	1 1/4"	115	4 17/32"	116	4 9/16"	19	3/4"	5/16"	M12x1.25x65	1	19	3/4"	141.026.103.1		
	434	1 3/8"	115	4 17/32"	116	4 9/16"	19	3/4"	5/16"	M12x1.25x65	1	21.5	27/32"	141.026.104.1		
	435	1 3/4"	115	4 17/32"	124	4 7/8"	24	7/8"	3/8"	M12x1.25x75	1	26.5	1 3/64"	141.026.105.1		
80	333	30	132	5 13/64"	124	4 7/8"	19	3/4"	8	M12x1.25x65	1	19	3/4"	141.028.135.1		
	334	35	132	5 13/64"	128	5 3/64"	24	7/8"	10	M12x1.25x80	1	21.5	27/32"	141.028.076.1		
	335	40	132	5 13/64"	128	5 3/64"	24	7/8"	12	M14x1.5x80	1	25	63/64"	141.028.077.1		
	336	45	132	5 13/64"	128	5 3/64"	24	7/8"	14	M12x1.25x80	1	26.5	1 3/64"	141.028.078.1		
90	335	40	137	5 25/64"	133	5 15/64"	24	7/8"	12	M14x1.5x80	1	25	63/64"	141.029.077.1		
	336	45	137	5 25/64"	133	5 15/64"	24	7/8"	14	M12x1.25x80	1	26.5	1 3/64"	141.029.078.1		

FORO LISCIO - CHIAVETTA - BULLONE INTERFERENTE INCASSATO
ROUND BORE - KEYWAY - INTERFERING RECESSED CLAMP BOLT

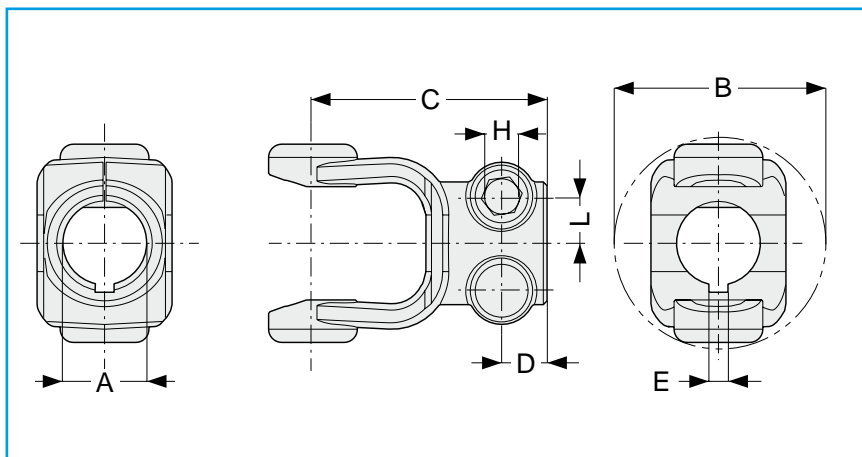
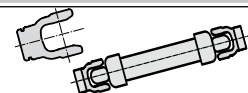

Type	Ref.	A		B		C		D		E	H		L		Code
		[mm]	[inch]	[mm]	[inch]	[mm]	[inch]	[mm]	[inch]		M...x.cl.8.8	Qty	[mm]	[inch]	
10	361	20	104	4 3/32"	101	3 31/32"	24	7/8"	6	M12x1.25x55	1	14.5	37/64"	141.021.335.1	
	362	25	104	4 3/32"	101	3 31/32"	24	7/8"	8	M12x1.25x55	1	17	43/64"	141.021.336.1	
	363	30	104	4 3/32"	101	3 31/32"	24	7/8"	8	M12x1.25x55	1	19	3/4"	141.021.337.1	
	461	3/4"	104	4 3/32"	101	3 31/32"	24	7/8"	3/16"	M12x1.25x55	1	13.5	37/64"	141.021.338.1	
	462	1"	104	4 3/32"	101	3 31/32"	24	7/8"	1/4"	M12x1.25x55	1	17	43/64"	141.021.339.1	
	361	20	104	4 3/32"	104	4 3/32"	24	7/8"	6	M12x1.25x55	1	14.5	37/64"	141.022.363.1	
20	362	25	104	4 3/32"	104	4 3/32"	24	7/8"	8	M12x1.25x55	1	17	43/64"	141.022.364.1	
	363	30	104	4 3/32"	104	4 3/32"	24	7/8"	8	M12x1.25x55	1	19	3/4"	141.022.365.1	
	461	3/4"	104	4 3/32"	104	4 3/32"	24	7/8"	3/16"	M12x1.25x55	1	13.5	37/64"	141.022.366.1	
	462	1"	104	4 3/32"	104	4 3/32"	24	7/8"	1/4"	M12x1.25x55	1	17	43/64"	141.022.367.1	
	463	1 1/4"	104	4 3/32"	104	4 3/32"	24	7/8"	5/16"	M12x1.25x55	1	19	3/4"	141.022.368.1	
	362	25	104	4 3/32"	113	4 29/64"	24	7/8"	8	M12x1.25x55	1	17	43/64"	141.024.477.1	
40	363	30	104	4 3/32"	113	4 29/64"	24	7/8"	8	M12x1.25x55	1	19	3/4"	141.024.478.1	
	364	35	104	4 3/32"	113	4 29/64"	24	7/8"	10	M12x1.25x55	1	21.5	27/32"	141.024.479.1	
	463	1 1/4"	104	4 3/32"	113	4 29/64"	24	7/8"	5/16"	M12x1.25x55	1	19	3/4"	141.024.480.1	
	464	1 3/8"	104	4 3/32"	113	4 29/64"	24	7/8"	5/16"	M12x1.25x55	1	21.5	27/32"	141.024.481.1	
	363	30	110	3 15/16"	116	4 9/16"	24	7/8"	8	M12x1.25x55	1	19	3/4"	141.025.382.1	
50	364	35	110	3 15/16"	116	4 9/16"	24	7/8"	10	M12x1.25x55	1	21.5	27/32"	141.025.383.1	
	463	1 1/4"	110	3 15/16"	116	4 9/16"	24	7/8"	5/16"	M12x1.25x55	1	19	3/4"	141.025.384.1	
	464	1 3/8"	110	3 15/16"	116	4 9/16"	24	7/8"	5/16"	M12x1.25x55	1	21.5	27/32"	141.025.385.1	
	363	30	115	4 17/32"	124	4 7/8"	24	7/8"	8	M12x1.25x55	1	19	3/4"	141.026.623.1	
	364	35	115	4 17/32"	124	4 7/8"	24	7/8"	10	M12x1.25x55	1	21.5	27/32"	141.026.624.1	
60	365	40	115	4 17/32"	124	4 7/8"	24	7/8"	12	M12x1.25x55	1	24	7/8"	141.026.625.1	
	366	45	115	4 17/32"	124	4 7/8"	24	7/8"	14	M12x1.25x55	1	26.5	1 3/64"	141.026.626.1	
	463	1 1/4"	115	4 17/32"	124	4 7/8"	24	7/8"	5/16"	M12x1.25x55	1	19	3/4"	141.026.627.1	
	464	1 3/8"	115	4 17/32"	124	4 7/8"	24	7/8"	5/16"	M12x1.25x55	1	21.5	27/32"	141.026.628.1	
	465	1 3/4"	115	4 17/32"	124	4 7/8"	24	7/8"	3/8"	M12x1.25x55	1	26.5	1 3/64"	141.026.629.1	
	363	30	132	5 13/64"	128	5 3/64"	24	7/8"	8	M12x1.25x55	1	19	3/4"	141.028.483.1	
80	364	35	132	5 13/64"	128	5 3/64"	24	7/8"	10	M12x1.25x55	1	21.5	27/32"	141.028.484.1	
	365	40	132	5 13/64"	128	5 3/64"	24	7/8"	12	M12x1.25x55	1	24	7/8"	141.028.485.1	
	366	45	132	5 13/64"	128	5 3/64"	24	7/8"	14	M12x1.25x55	1	26.5	1 3/64"	141.028.486.1	
90	365	40	137	5 25/64"	136	5 23/64"	24	7/8"	12	M12x1.25x55	1	24	7/8"	141.029.346.1	
	366	45	137	5 25/64"	136	5 23/64"	24	7/8"	14	M12x1.25x55	1	26.5	1 3/64"	141.029.347.1	

FORO LISCIO - CHIAVETTA - BULLONE NON INTERFERENTE
ROUND BORE - KEYWAY - NOT INTERFERING CLAMP BOLT

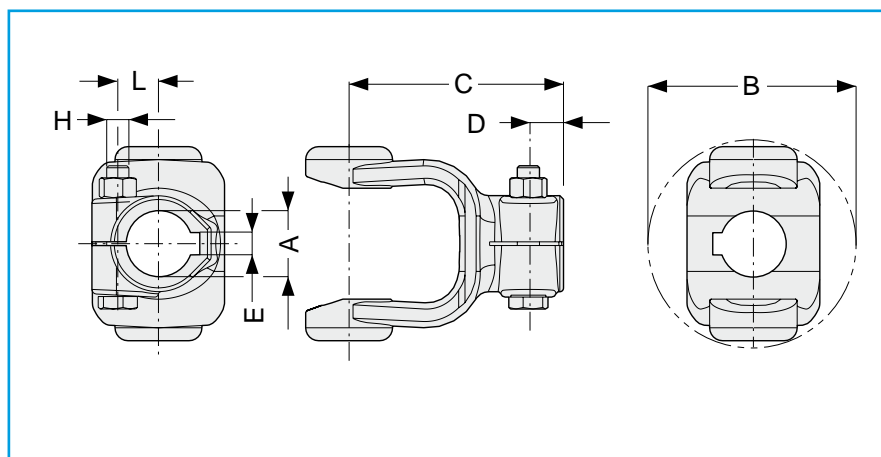
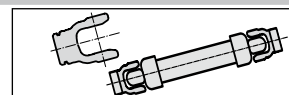

Forcelle per cardani
Yokes for PTO driveshafts

Type	Ref.	A		B		C		D		E	H		L		Code
		[mm]	[inch]	[mm]	[inch]	[mm]	[inch]	[mm]	[inch]		M...cl.8.8	Qty	[mm]	[inch]	
10	341	20	73	2 7/8"	90	3 35/64"	19	3/4"	6	M10x1.25x65	1	17	43/64"	141.021.076.1	
	342	25	73	2 7/8"	90	3 35/64"	19	3/4"	8	M10x1.25x65	1	20	25/32"	141.021.037.1	
	343	30	73	2 7/8"	90	3 35/64"	19	3/4"	8	M10x1.25x65	1	22	55/64"	141.021.038.1	
	441	3/4"	73	2 7/8"	90	3 35/64"	19	3/4"	3/16"	M10x1.25x65	1	16	5/8"	141.021.077.1	
	442	1"	73	2 7/8"	90	3 35/64"	19	3/4"	1/4"	M10x1.25x65	1	20	43/64"	141.021.078.1	
20	341	20	80	3 5/32"	99	3 57/64"	19	3/4"	6	M10x1.25x65	1	17	43/64"	141.022.020.1	
	342	25	80	3 5/32"	99	3 57/64"	19	3/4"	8	M10x1.25x65	1	20	25/32"	141.022.021.1	
	343	30	80	3 5/32"	99	3 57/64"	19	3/4"	8	M10x1.25x65	1	22	55/64"	141.022.022.1	
	441	3/4"	80	3 5/32"	99	3 57/64"	19	3/4"	3/16"	M10x1.25x65	1	16	5/8"	141.022.072.1	
	442	1"	80	3 5/32"	99	3 57/64"	19	3/4"	1/4"	M10x1.25x65	1	20	43/64"	141.022.073.1	
	443	1 1/4"	80	3 5/32"	99	3 57/64"	19	3/4"	5/16"	M10x1.25x65	1	22	55/64"	141.022.133.1	
40	342	25	94	3 45/64"	107	4 7/32"	19	3/4"	8	M10x1.25x65	1	20	25/32"	141.024.078.1	
	343	30	94	3 45/64"	107	4 7/32"	19	3/4"	8	M10x1.25x65	1	22	55/64"	141.024.029.1	
	344	35	94	3 45/64"	107	4 7/32"	19	3/4"	10	M10x1.25x65	1	23.5	59/64"	141.024.028.1	
	443	1 1/4"	94	3 45/64"	107	4 7/32"	19	3/4"	5/16"	M10x1.25x65	1	22	55/64"	141.024.032.1	
	444	1 3/8"	94	3 45/64"	107	4 7/32"	19	3/4"	5/16"	M10x1.25x65	1	23.5	59/64"	141.024.080.1	
50	343	30	100	3 15/16"	109	4 19/64"	19	3/4"	8	M10x1.25x65	1	22	55/64"	141.025.081.1	
	344	35	100	3 15/16"	109	4 19/64"	19	3/4"	10	M10x1.25x65	1	23.5	59/64"	141.025.026.1	
	345	40	100	3 15/16"	109	4 19/64"	19	3/4"	12	M10x1.25x65	1	26	1 1/32"	141.025.082.1	
	443	1 1/4"	100	3 15/16"	109	4 19/64"	19	3/4"	5/16"	M10x1.25x65	1	22	55/64"	141.025.083.1	
	444	1 3/8"	100	3 15/16"	109	4 19/64"	19	3/4"	5/16"	M10x1.25x65	1	23.5	59/64"	141.025.084.1	
60	343	30	115	4 7/32"	116	4 9/16"	19	3/4"	8	M10x1.25x65	1	22	55/64"	141.026.040.1	
	344	35	115	4 7/32"	116	4 9/16"	19	3/4"	10	M10x1.25x65	1	23.5	59/64"	141.026.041.1	
	345	40	115	4 7/32"	124	4 7/8"	24	15/16"	12	M12x1.25x75	1	27	1 1/16"	141.026.052.1	
	346	45	115	4 7/32"	124	4 7/8"	24	15/16"	14	M14x1.5x80	1	30.5	1 13/64"	141.026.055.1	
	443	1 1/4"	115	4 7/32"	116	4 9/16"	19	3/4"	5/16"	M10x1.25x65	1	23.5	59/64"	141.026.059.1	
	444	1 3/8"	115	4 7/32"	116	4 9/16"	19	3/4"	5/16"	M10x1.25x65	1	23.5	59/64"	141.026.106.1	
80	445	1 3/4"	115	4 7/32"	124	4 7/8"	24	15/16"	3/8"	M12x1.25x75	1	29.5	1 5/32"	141.026.075.1	
	344	35	132	5 13/64"	124	4 7/8"	19	3/4"	10	M12x1.25x80	1	24.5	31/32"	141.028.042.1	
	345	40	132	5 13/64"	128	5 3/64"	24	15/16"	12	M12x1.25x80	1	27	1 1/16"	141.028.043.1	
90	346	45	132	5 13/64"	128	5 3/64"	24	15/16"	14	M12x1.25x80	1	29.5	1 5/32"	141.028.044.1	
	345	40	137	5 25/64"	133	5 15/64"	24	7/8"	12	M14x1.5x80	1	28	1 7/64"	141.029.079.1	
	346	45	137	5 25/64"	133	5 15/64"	24	7/8"	14	M14x1.5x80	1	30.5	1 13/64"	141.029.080.1	

FORO LISCIO - CHIAVETTA
ROUND BORE - KEYWAY

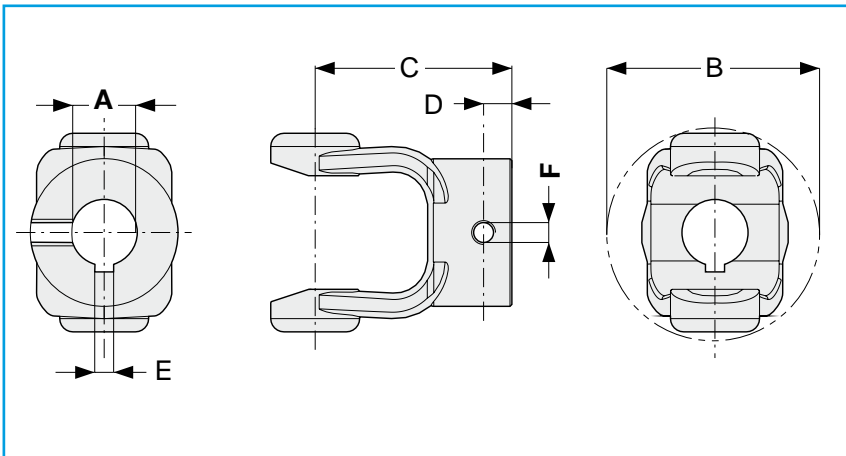
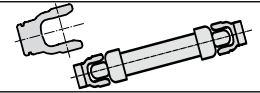

Type	Ref.	A		B		C		D		E	F	Code
		[mm]	[inch]	[mm]	[inch]	[mm]	[inch]	[mm]	[inch]			
10	311	20	73	2 7/8"	80	3 5/32"	20	25/32"	6	M8	151.011.061.1	
	312	25	73	2 7/8"	80	3 5/32"	20	25/32"	8	M10	151.011.062.1	
	313	30	73	2 7/8"	80	3 5/32"	20	25/32"	8	M10	151.011.063.1	
	411	3/4"	73	2 7/8"	80	3 5/32"	20	25/32"	3/16"	3/8" 16UNC	151.011.064.1	
	412	1"	73	2 7/8"	80	3 5/32"	20	25/32"	1/4"	3/8" 16UNC	151.011.065.1	
	413	1 1/4"	73	2 7/8"	80	3 5/32"	20	25/32"	5/16"	3/8" 16UNC	151.011.270.1	
20	311	20	80	3 5/32"	80	3 5/32"	20	25/32"	6	M8	151.012.054.1	
	312	25	80	3 5/32"	80	3 5/32"	20	25/32"	8	M10	151.012.055.1	
	313	30	80	3 5/32"	80	3 5/32"	20	25/32"	8	M10	151.012.056.1	
	411	3/4"	80	3 5/32"	80	3 5/32"	20	25/32"	3/16"	3/8" 16UNC	151.012.057.1	
	412	1"	80	3 5/32"	80	3 5/32"	20	25/32"	1/4"	3/8" 16UNC	151.012.058.1	
	413	1 1/4"	80	3 5/32"	80	3 5/32"	20	25/32"	5/16"	3/8" 16UNC	151.012.059.1	
40	312	25	94	3 45/64"	91.5	3 39/64"	20	25/32"	8	M12	151.014.062.1	
	313	30	94	3 45/64"	91.5	3 39/64"	20	25/32"	8	M12	151.014.063.1	
	314	35	94	3 45/64"	91.5	3 39/64"	20	25/32"	10	M12	151.014.064.1	
	413	1 1/4"	94	3 45/64"	91.5	3 39/64"	20	25/32"	5/16"	3/8" 16UNC	151.014.065.1	
	414	1 3/8"	94	3 45/64"	91.5	3 39/64"	20	25/32"	5/16"	3/8" 16UNC	151.014.066.1	
50	313	30	100	3 15/16"	97	3 13/16"	20	25/32"	8	M12	151.015.066.1	
	314	35	100	3 15/16"	97	3 13/16"	20	25/32"	10	M12	151.015.067.1	
	315	40	100	3 15/16"	97	3 13/16"	20	25/32"	12	M12	151.015.068.1	
	413	1 1/4"	100	3 15/16"	97	3 13/16"	20	25/32"	5/16"	3/8" 16UNC	151.015.069.1	
	414	1 3/8"	100	3 15/16"	97	3 13/16"	20	25/32"	5/16"	3/8" 16UNC	151.015.070.1	
60	313	30	115	4 17/32"	104	4 3/32"	20	25/32"	8	M12	151.016.088.1	
	314	35	115	4 17/32"	104	4 3/32"	20	25/32"	10	M12	151.016.089.1	
	315	40	115	4 17/32"	104	4 3/32"	20	25/32"	12	M12	151.016.090.1	
	413	1 1/4"	115	4 17/32"	104	4 3/32"	20	25/32"	5/16"	3/8" 16UNC	151.016.091.1	
	414	1 3/8"	115	4 17/32"	104	4 3/32"	20	25/32"	5/16"	3/8" 16UNC	151.016.092.1	
	415	1 3/4"	115	4 17/32"	104	4 3/32"	20	25/32"	3/8"	3/8" 16UNC	151.016.093.1	
80	314	35	132	5 13/64"	116	4 9/16"	20	25/32"	10	M14	151.018.070.1	
	315	40	132	5 13/64"	116	4 9/16"	20	25/32"	12	M14	151.018.071.1	
	316	45	132	5 13/64"	116	4 9/16"	20	25/32"	14	M14	151.018.072.1	
90	315	40	137	5 25/64"	124	4 7/8"	25	63/64"	12	M14	151.019.073.1	
	316	45	137	5 25/64"	124	4 7/8"	25	63/64"	14	M14	151.019.074.1	

FOR LISCIO - CHIAVETTA - FORO SPINA
ROUND BORE - KEYWAY - PIN HOLE

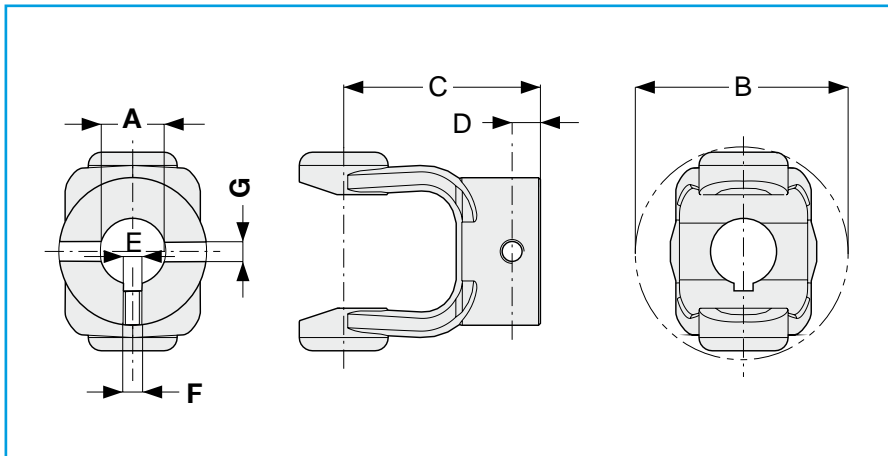
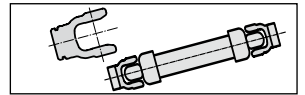

Forcelle per cardani
 Yokes for PTO driveshafts

Type	Ref.	A		B		C		D		E	F		L		Code
		[mm]	[inch]	[mm]	[inch]	[mm]	[inch]	[mm]	[inch]		[mm]	[inch]			
10	500	19.05	73	2 7/8"	80	3 5/32"	20	25/32"	4.76	3/8" 16UNC	6.35	1/4"	151.011.300.1		
	510	25.4	73	2 7/8"	80	3 5/32"	20	25/32"	6.35	3/8" 16UNC	6.35	1/4"	151.011.301.1		
	511	25.4	73	2 7/8"	80	3 5/32"	20	25/32"	6.35	3/8" 16UNC	7.93	5/16"	151.011.302.1		
	520	31.75	73	2 7/8"	80	3 5/32"	20	25/32"	6.35	3/8" 16UNC	7.93	5/16"	151.011.303.1		
20	510	25.4	80	3 5/32"	80	3 5/32"	20	25/32"	6.35	3/8" 16UNC	6.35	1/4"	151.012.301.1		
	511	25.4	80	3 5/32"	80	3 5/32"	20	25/32"	6.35	3/8" 16UNC	7.93	5/16"	151.012.302.1		
	520	31.75	80	3 5/32"	80	3 5/32"	20	25/32"	6.35	3/8" 16UNC	7.93	5/16"	151.012.303.1		
	530	25.4	80	3 5/32"	80	3 5/32"	20	25/32"	6.35	1/4" 20 UNC	7	9/32"	151.012.304.1		
40	511	25.4	94	3 45/64"	91.5	3 39/64"	20	25/32"	6.35	3/8" 16UNC	7.93	5/16"	151.014.302.1		
	520	31.75	94	3 45/64"	91.5	3 39/64"	20	25/32"	6.35	3/8" 16UNC	7.93	5/16"	151.014.303.1		
	540	31.75	94	3 45/64"	91.5	3 39/64"	20	25/32"	7.93	3/8" 16UNC	7.93	5/16"	151.014.305.1		
	550	34.92	94	3 45/64"	91.5	3 39/64"	20	25/32"	7.93	3/8" 16UNC	7.93	5/16"	151.014.306.1		
	560	38.1	94	3 45/64"	91.5	3 39/64"	20	25/32"	9.52	3/8" 16UNC	7.93	5/16"	151.014.307.1		
50	520	31.75	100	3 15/16"	97	3 13/16"	20	25/32"	6.35	3/8" 16UNC	7.93	5/16"	151.015.303.1		
	540	31.75	100	3 15/16"	97	3 13/16"	20	25/32"	7.93	3/8" 16UNC	7.93	5/16"	151.015.305.1		
	550	34.92	100	3 15/16"	97	3 13/16"	20	25/32"	7.93	3/8" 16UNC	7.93	5/16"	151.015.306.1		
	560	38.1	100	3 15/16"	97	3 13/16"	20	25/32"	9.52	3/8" 16UNC	7.93	5/16"	151.015.307.1		
60	520	31.75	115	4 17/32"	104	4 3/32"	20	25/32"	6.35	3/8" 16UNC	7.93	5/16"	151.016.303.1		
	540	31.75	115	4 17/32"	104	4 3/32"	20	25/32"	7.93	3/8" 16UNC	7.93	5/16"	151.016.305.1		
	550	34.92	115	4 17/32"	104	4 3/32"	20	25/32"	7.93	3/8" 16UNC	7.93	5/16"	151.016.306.1		
	560	38.1	115	4 17/32"	104	4 3/32"	20	25/32"	9.52	3/8" 16UNC	7.93	5/16"	151.016.307.1		
	570	44.45	115	4 17/32"	104	4 3/32"	25.4	1"	9.52	3/8" 16UNC	7.93	5/16"	151.016.308.1		
	580	49.2	115	4 17/32"	104	4 3/32"	20	25/32"	12.7	3/8" 16UNC	7.93	5/16"	151.016.309.1		
	590	38.1	115	4 17/32"	104	4 3/32"	20	25/32"	9.52	3/8" 16UNC	9.52	3/8"	151.016.310.1		
80	550	34.92	132	5 13/64"	116	4 9/16"	25	63/64"	7.93	3/8" 16UNC	7.93	5/16"	151.018.306.1		
	580	49.2	132	5 13/64"	116	4 9/16"	25	63/64"	12.7	3/8" 16UNC	7.93	5/16"	151.018.309.1		
	590	38.1	132	5 13/64"	116	4 9/16"	25	63/64"	9.52	3/8" 16UNC	9.52	3/8"	151.018.310.1		
	600	44.45	132	5 13/64"	116	4 9/16"	25	63/64"	9.52	3/8" 16UNC	9.52	3/8"	151.018.311.1		
	610	50.8	132	5 13/64"	116	4 9/16"	25	63/64"	12.7	3/8" 16UNC	9.52	3/8"	151.018.312.1		
90	580	49.2	137	5 25/64"	124	4 7/8"	25	63/64"	12.7	3/8" 16UNC	7.93	5/16"	151.019.309.1		
	590	38.1	137	5 25/64"	124	4 7/8"	25	63/64"	9.52	3/8" 16UNC	9.52	3/8"	151.019.310.1		
	600	44.45	137	5 25/64"	124	4 7/8"	25	63/64"	9.52	3/8" 16UNC	9.52	3/8"	151.019.311.1		
	610	50.8	137	5 25/64"	124	4 7/8"	25	63/64"	12.7	3/8" 16UNC	9.52	3/8"	151.019.312.1		

FORO LISIO - FORO SPINA
ROUND BORE - PINE HOLE

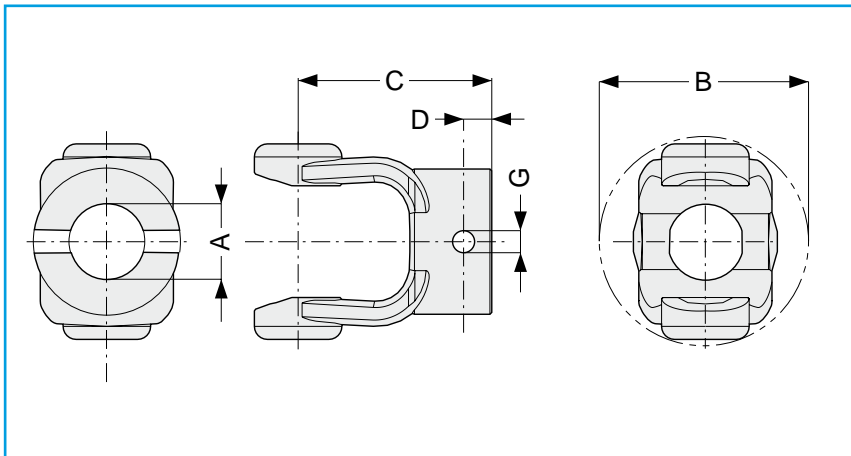
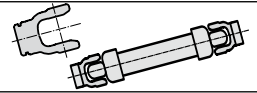

Type	Ref.	A	B		C		D		G	Code
			[mm]	[inch]	[mm]	[inch]	[mm]	[inch]		
10	321	20	73	2 7/8"	80	3 5/32"	15	19/32"	6	151.011.066.1
	322	25	73	2 7/8"	80	3 5/32"	15	19/32"	8	151.011.067.1
	323	30	73	2 7/8"	80	3 5/32"	15	19/32"	10	151.011.068.1
	421	3/4"	73	2 7/8"	80	3 5/32"	15	19/32"	3/8"	151.011.069.1
	422	1"	73	2 7/8"	80	3 5/32"	15	19/32"	3/8"	151.011.070.1
20	321	20	80	3 5/32"	80	3 5/32"	15	19/32"	6	151.012.060.1
	322	25	80	3 5/32"	80	3 5/32"	15	19/32"	8	151.012.061.1
	323	30	80	3 5/32"	80	3 5/32"	15	19/32"	10	151.012.062.1
	421	3/4"	80	3 5/32"	80	3 5/32"	15	19/32"	3/8"	151.012.063.1
	422	1"	80	3 5/32"	80	3 5/32"	15	19/32"	3/8"	151.012.064.1
	423	1 1/4"	80	3 5/32"	80	3 5/32"	15	19/32"	3/8"	151.012.065.1
40	322	25	94	3 45/64"	91.5	3 39/64"	20	25/32"	8	151.014.067.1
	323	30	94	3 45/64"	91.5	3 39/64"	20	25/32"	10	151.014.068.1
	324	35	94	3 45/64"	91.5	3 39/64"	20	25/32"	13	151.014.069.1
	423	1 1/4"	94	3 45/64"	91.5	3 39/64"	20	25/32"	3/8"	151.014.070.1
	424	1 3/8"	94	3 45/64"	91.5	3 39/64"	20	25/32"	3/8"	151.014.071.1
50	323	30	100	3 15/16"	97	3 13/16"	20	25/32"	10	151.015.071.1
	324	35	100	3 15/16"	97	3 13/16"	20	25/32"	13	151.015.072.1
	325	40	100	3 15/16"	97	3 13/16"	20	25/32"	13	151.015.073.1
	423	1 1/4"	100	3 15/16"	97	3 13/16"	20	25/32"	3/8"	151.015.074.1
	424	1 3/8"	100	3 15/16"	97	3 13/16"	20	25/32"	3/8"	151.015.075.1
60	323	30	115	4 17/32"	104	4 3/32"	20	25/32"	10	151.016.094.1
	324	35	115	4 17/32"	104	4 3/32"	20	25/32"	13	151.016.095.1
	325	40	115	4 17/32"	104	4 3/32"	20	25/32"	13	151.016.096.1
	423	1 1/4"	115	4 17/32"	104	4 3/32"	20	25/32"	3/8"	151.016.097.1
	424	1 3/8"	115	4 17/32"	104	4 3/32"	20	25/32"	3/8"	151.016.098.1
	425	1 3/4"	115	4 17/32"	104	4 3/32"	20	25/32"	3/8"	151.016.099.1
80	324	35	132	5 13/64"	116	4 9/16"	25	63/64"	13	151.018.073.1
	325	40	132	5 13/64"	116	4 9/16"	25	63/64"	13	151.018.074.1
	326	45	132	5 13/64"	116	4 9/16"	25	63/64"	13	151.018.075.1
90	325	40	137	5 25/64"	124	4 7/8"	25	63/64"	13	151.019.075.1
	326	45	137	5 25/64"	124	4 7/8"	25	63/64"	13	151.019.076.1

FLANGIA C04 FLANGE C04

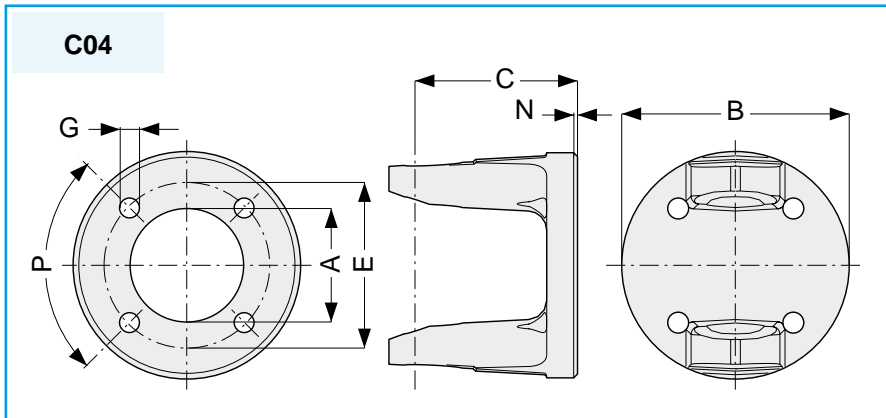
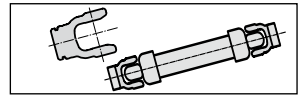

Forcelle per cardani
Yokes for PTO driveshafts

Type	Ref.	A		B		C		N		E		P	G		Code
		[mm]	[inch]	[mm]	[inch]	[mm]	[inch]	[mm]	[inch]	[mm]	[inch]	[deg]	[mm]	[inch]	
10	C04	47	1 27/32"	90	3 35/64"	48	1 57/64"	2.5	3/32"	74.5	2 15/16"	90°	8.5	21/64"	151.011.097.1
20	C04	47	1 27/32"	90	3 35/64"	53	2 3/32"	2.5	3/32"	74.5	2 15/16"	90°	8.5	21/64"	151.012.083.1
40	C04	57	2 1/4"	100	3 15/16"	64	2 33/64"	2.5	3/32"	84	3 5/16"	90°	10.5	13/32"	151.014.101.1
50	C04	57	2 1/4"	100	3 15/16"	66	2 19/32"	2.5	3/32"	84	3 5/16"	90°	10.5	13/32"	151.015.097.1
60	C04	57	2 1/4"	110	4 21/64"	74	2 29/32"	2.5	3/32"	94	3 45/64"	90°	10.5	13/32"	151.016.114.1
80	C04	85	3 11/32"	125	4 59/64"	79	3 7/64"	3.5	9/64"	100	3 15/16"	90°	14.5	37/64"	151.018.083.1

FLANGIA FGL FLANGE FGL

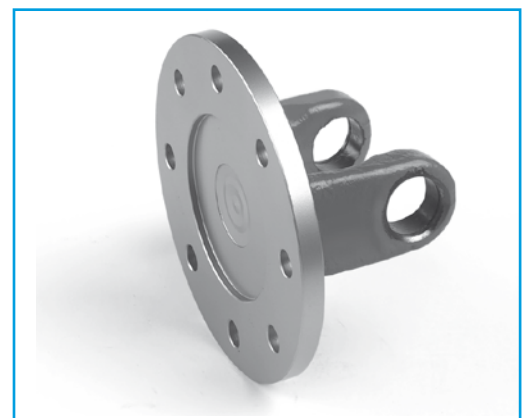
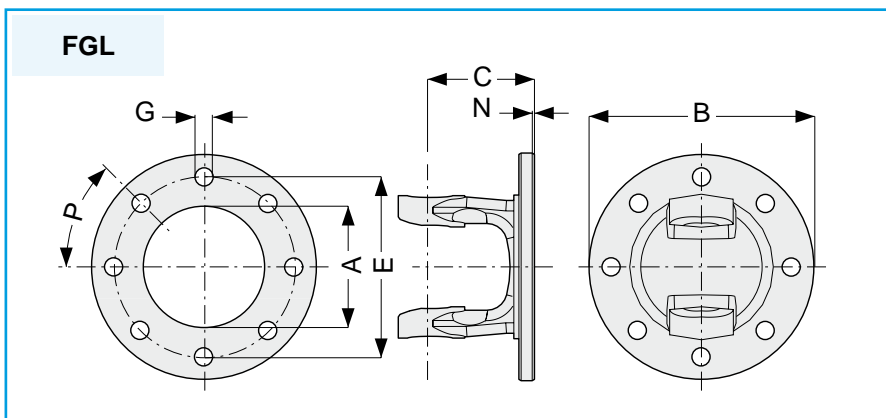
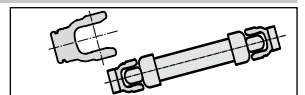

Type	Ref.	A		B		C		N		E		P	G		Code
		[mm]	[inch]	[mm]	[inch]	[mm]	[inch]	[mm]	[inch]	[mm]	[inch]	[deg]	[mm]	[inch]	
60	FGL	90	3 35/64"	168	6 39/64"	77	3 1/32"	4	5/32"	133	5 15/64"	45°	13	33/64"	151.016.543.1
80	FGL	90	3 35/64"	168	6 39/64"	96	3 25/32"	4	5/32"	133	5 15/64"	45°	13	33/64"	151.018.417.1
90	FGL	90	3 35/64"	168	6 39/64"	101	3 31/32"	4	5/32"	133	5 15/64"	45°	13	33/64"	151.019.316.1
120	FGL	90	3 35/64"	168	6 39/64"	138	5 7/16"	4	5/32"	133	5 15/64"	45°	13	33/64"	141.220.011.1

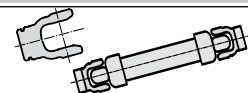

KIT COLLAR PER FORCELLE / COLLAR SET FOR YOKES

		A	Code
	C1	1 3/8"	165.000.628
		1 3/4"	165.000.629
C2	1 3/4"	165.000.766	



KIT PULSANTE / PUSH-PIN SET

	A	Code
	1 3/8"	166.026.004
	1 3/4"	166.026.005

KIT BULLONI STRINGIMENTO / BOLT AND Nut SET

<p>Kit composti da nr. 1 vite + nr. 1 dado Sets included nr. 1 bolt and nr. 1 nut</p>	M...x...cl.8.8	 [Nm.Max]	Code
	M10x1.25x65	55 ÷ 60	165.000.510
	M12x1.25x55	90 ÷ 100	165.000.617
	M12x1.25x65	90 ÷ 100	165.000.502
	M12x1.25x70	90 ÷ 100	165.000.525
	M12x1.25x75	90 ÷ 100	165.000.598
	M12x1.25x80	90 ÷ 100	165.000.555
	M14x1.5x80	145 ÷ 155	165.000.691
	M16x2x80	210 ÷ 220	165.000.576
	M16x2x90	210 ÷ 220	165.000.767

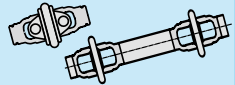
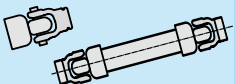
SNODI E FORCELLE DOPPIE JOINTS AND DOUBLE YOKES

			p.
SNODI PER CARDANI OMOCINETICI CVJ JOINT FOR PTO DRIVESHAFTS CVJ			46
Serie V	<i>V Series</i>		46
Serie T	<i>T Series</i>		46
SNODI PER CARDANI JOINT FOR PTO DRIVESHAFTS			47
Serie V	<i>V Series</i>		47
Serie T	<i>T Series</i>		47
Serie E	<i>E Seires</i>		48
Serie D	<i>D Seires</i>		49
FORCELLE DOPPIE DOUBLE YOKES			50
SD	<i>SD</i>		50
SH	<i>SH</i>		50
SF	<i>SF</i>		51
Parti di ricambio SF	<i>SF Spare Parts</i>		52

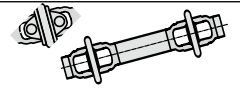

SERIE V / V SERIES

Ingrassatore assiale
Axial Greaser

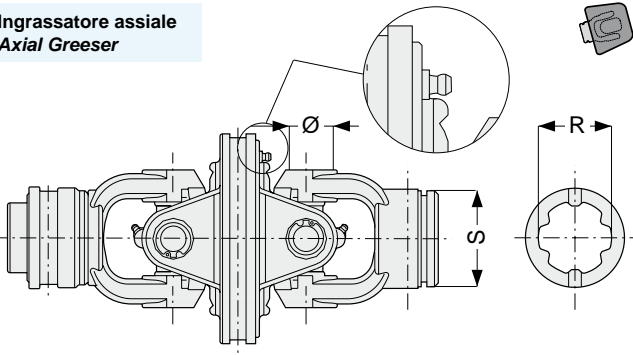

Ingrassatore radiale
Radial Greaser

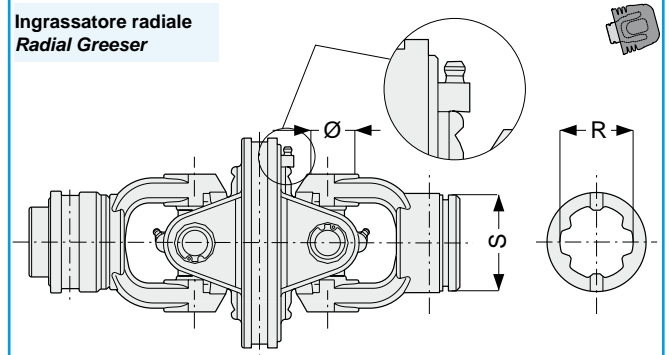

Type	Ref.	Ø		R		S		Snodo esterno		Snodo interno		Posizione ingrassatore		Posizione ingrassatore	
								Outer Joint		Inner Joint		Greaser Position		Greaser Position	
								Assiale / Axial	Radiale / Radial	Assiale / Axial	Radiale / Radial	Code	Code	Code	Code
[mm]	[inch]	[mm]	[inch]	[mm]	[inch]	[mm]	[inch]	[mm]	[inch]	[mm]	[inch]	[mm]	[inch]	[mm]	[inch]
20	C02	23.8	1 5/16"	42	1 21/32"	53.9	2 1/8"	121.022.670.01	121.022.720.01	36.2	1 27/64"	46.9	1 27/32"	121.022.671.01	121.022.729.01
40	C02	27	1 51/64"	45.7	1 51/64"	61	2 13/32"	121.024.786.01	121.024.893.01	39.3	1 35/64"	53.9	2 1/8"	121.024.792.01	121.024.862.01
60	C02	30.2	2 17/64"	57.6	2 17/64"	75.5	2 31/32"	121.026.930.01	121.026.102.01	50.2	1 31/32"	67	2 41/64"	121.026.941.01	121.026.304.01
80	C02	35	2 5/8"	66.5	3 15/32"	88	3 15/32"	121.028.812.01	121.028.969.01	58.1	2 9/32"	76	2 63/64"	121.028.851.01	121.028.131.01

SERIE T / T SERIES

Ingrassatore assiale
Axial Greaser

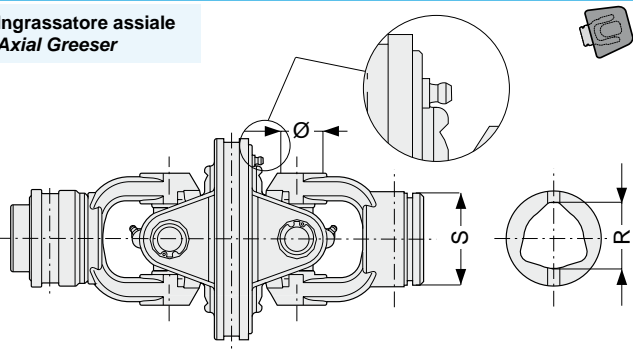

Ingrassatore radiale
Radial Greaser

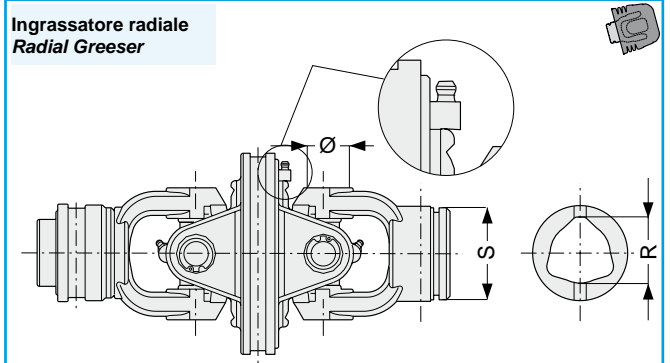

Type	Ref.	Ø		R		S		Snodo esterno		Snodo interno		Posizione ingrassatore		Posizione ingrassatore	
								Outer Joint		Inner Joint		Greaser Position		Greaser Position	
								Assiale / Axial	Radiale / Radial	Assiale / Axial	Radiale / Radial	Code	Code	Code	Code
[mm]	[inch]	[mm]	[inch]	[mm]	[inch]	[mm]	[inch]	[mm]	[inch]	[mm]	[inch]	[mm]	[inch]	[mm]	[inch]
20	C02	23.8	1 5/16"	36	1 27/64"	53.9	2 1/8"	121.022.641.01	121.022.730.01	29	1 9/64"	46.9	1 27/32"	121.022.659.01	121.022.731.01
40	C02	27	1 51/64"	43.5	1 23/32"	61	2 13/32"	121.024.630.01	121.024.909.01	36	1 27/64"	53.9	2 1/8"	121.024.629.01	121.024.910.01
60	C02	30.2	2 17/64"	54	2 1/8"	75.5	2 31/32"	121.026.658.01	121.026.062.01	45	1 49/64"	67	2 41/64"	121.026.950.01	121.026.316.01
80	C02	35	2 5/8"	63	3 31/64"	88	3 15/32"	121.028.657.01	121.028.132.01	54	2 1/8"	76	2 63/64"	121.028.836.01	121.028.133.01

I codici indicati si riferiscono a giunti che prevedano da un lato una forcella scanalata ad attacco rapido 1 3/8" Z6 (Ref. C02) e dall'altro lato una forcella per il tubo sagomato. **A richiesta i giunti possono essere forniti con estremità di tipo diverso previste nella gamma di produzione Comer Industries driveshafts.** In tal caso per effettuare l'ordine specificare la referenza della forcella che si vuole sia fornita con la forcella per il tubo sagomato.

Es.: **Snodo CVJ esterno T80 ~~C02~~ C03**

The codes indicated refer to joints with a grooved yoke and 1 3/8" Z6 rapid connector (Ref. C02) on one end and a yoke for the shaped tube on the other. **On request, joints can be supplied with different terminals than those available in the Comer Industries driveshafts line.** In that case, when ordering specify the yoke reference to be supplied with the yoke for the shaped tube.

Ex.: **Outer joint CVJ T80 ~~C02~~ C03**

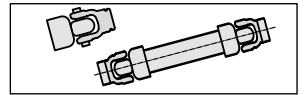

SERIE V / V SERIES

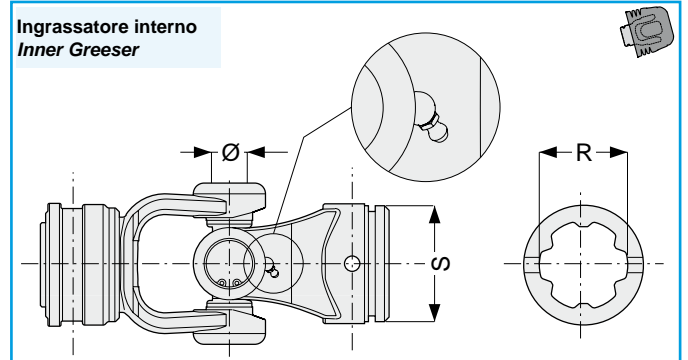
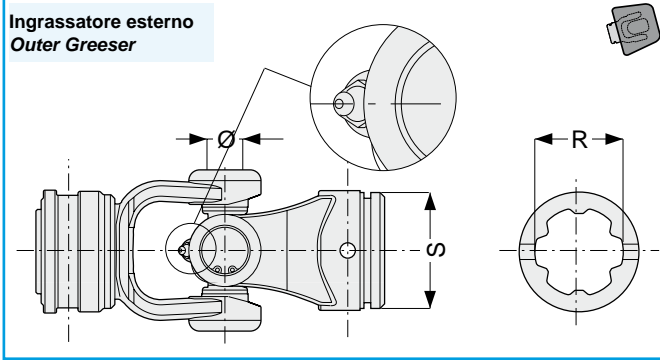

Type	Ref.	Snodo esterno Outer Joint								Snodo interno Inner Joint							
		Ø		R		S		Posizione ingrassatore Greaser Position		R		S		Posizione ingrassatore Greaser Position			
		[mm]	[inch]	[mm]	[inch]	[mm]	[inch]	Esterno / Outer Code	Interno / Inner Code	[mm]	[inch]	[mm]	[inch]	Esterno / Outer Code	Interno / Inner Code		
20	C12	23.8	15/16"	42	1 21/32"	53.9	2 1/8"	121.022.654.01	121.022.718.01	36.2	1 27/64"	46.9	1 27/32"	121.022.660.01	121.022.719.01		
40	C12	27	1 1/16"	45.7	1 51/64"	61	2 13/32"	121.024.771.01	121.024.830.01	39.3	1 35/64"	53.9	2 1/8"	121.024.772.01	121.024.884.01		
50	C12	30.2	1 3/16"	57.6	2 17/64"	70	2 3/4"	121.025.656.01	121.025.721.01	50.2	1 31/32"	61	2 13/32"	121.025.657.01	121.025.731.01		
60	C12	30.2	1 3/16"	57.6	2 17/64"	75.5	2 31/32"	121.026.911.01	121.026.116.01	50.2	1 31/32"	67	2 41/64"	121.026.912.01	121.026.230.01		
80	C12	35	1 3/8"	66.5	3 15/32"	88	3 15/32"	121.028.804.01	121.028.099.01	58.1	2 9/32"	76	2 63/64"	121.028.813.01	121.028.110.01		
90	C12	41	1 39/64"	66.5	3 15/32"	88	3 15/32"	121.029.552.01	121.029.663.01	58.1	2 9/32"	76	2 63/64"	121.029.569.01	121.029.666.01		

SERIE T / T SERIES

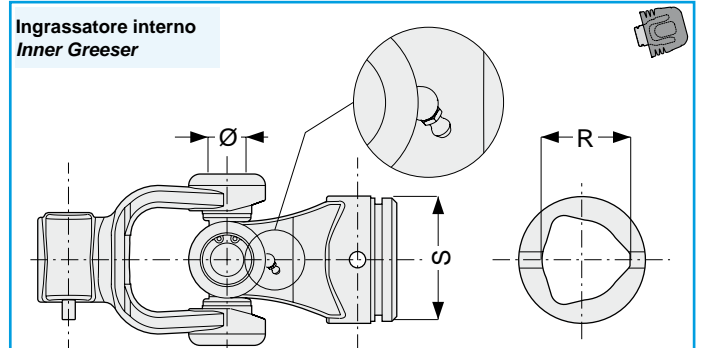
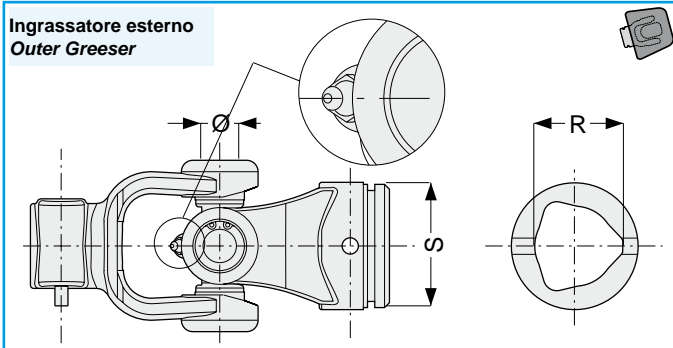

Type	Ref.	Snodo esterno Outer Joint								Snodo interno Inner Joint							
		Ø		R		S		Posizione ingrassatore Greaser Position		R		S		Posizione ingrassatore Greaser Position			
		[mm]	[inch]	[mm]	[inch]	[mm]	[inch]	Esterno / Outer Code	Interno / Inner Code	[mm]	[inch]	[mm]	[inch]	Esterno / Outer Code	Interno / Inner Code		
10	112	22	55/64"	32.5	1 9/32"	46.9	1 27/32"	121.021.501.11	121.021.652.11	26.5	1 3/64"	40.9	1 39/64"	121.021.500.11	121.021.651.11		
20	112	23.8	15/16"	36	1 27/64"	53.9	2 1/8"	121.022.501.11	121.022.715.11	29	1 9/64"	46.9	1 27/32"	121.022.500.11	121.022.714.11		
40	112	27	1 51/64"	43.5	1 23/32"	61	2 13/32"	121.024.507.11	121.024.621.11	36	1 27/64"	53.9	2 1/8"	121.024.506.11	121.024.622.11		
50	112	30.2	2 17/64"	51.6	2 1/32"	70	2 3/4"	121.025.506.11	121.025.602.11	45	1 49/64"	61	2 13/32"	121.025.507.11	121.025.726.11		
60	112	30.2	2 17/64"	54	2 1/8"	75.5	2 31/32"	121.026.516.11	121.026.187.11	45	1 49/64"	67	2 41/64"	121.026.515.11	121.026.231.11		
80	112	35	2 5/8"	63	3 31/64"	88	3 15/32"	121.028.593.11	121.028.083.11	54	2 1/8"	76	2 63/64"	121.028.592.11	121.028.112.11		
90	112	41	1 39/64"	63	3 31/64"	88	3 15/32"	121.029.505.11	121.029.667.11	54	2 1/8"	76	2 63/64"	121.029.504.11	121.029.668.11		

I codici indicati si riferiscono a giunti che prevedano da un lato una forcella scanalata ad attacco rapido 1 3/8" Z6 (Ref. 112) e dall'altro lato una forcella per il tubo sagomato. **A richiesta i giunti possono essere forniti con estremità di tipo diverso previste nella gamma di produzione Comer Industries driveshafts.** In tal caso per effettuare l'ordine specificare la referenza della forcella che si vuole sia fornita con la forcella per il tubo sagomato.

The codes indicated refer to joints with a grooved yoke and 1 3/8" Z6 rapid connector (Ref. 112) on one end and a yoke for the shaped tube on the other. **On request, joints can be supplied with different terminals than those available in the Comer Industries driveshafts. line.** In that case, when ordering specify the yoke reference to be supplied with the yoke for the shaped tube.

Es.: Snodo CVJ esterno T80 ~~112~~ 113

Ex.: Outer joint CVJ T80 ~~112~~ 113

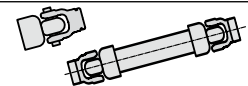

SERIE E / E SERIES

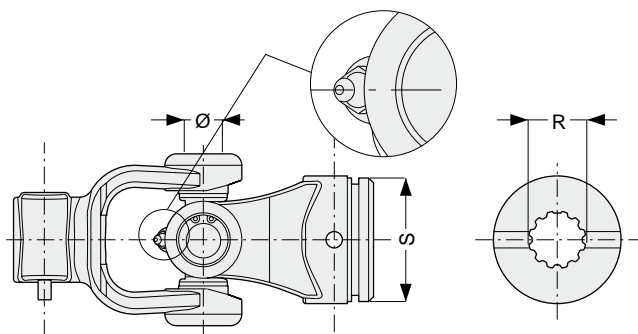

Type	Ref.	Ø		Snodo interno Inner Joint			Code
		[mm]	[inch]	R	S		
					[mm]	[inch]	
40	112	27	1 1/16"	30 CUNA	53.9	2 1/8"	121.024.601.11
50	112	30.2	1 3/16"	35 CUNA	61	2 13/32"	121.025.512.11
60	112	30.2	1 3/16"	35 CUNA	67	2 41/64"	121.026.526.11
80	112	35	1 3/8"	40 CUNA	76	2 63/64	121.028.619.11
90	112	41	1 39/64"	45 CUNA	76	2 63/64	121.029.515.11

I codici indicati si riferiscono a giunti che prevedano da un lato una forcella scanalata ad attacco rapido 1 3/8" Z6 (Ref. 112) e dall'altro lato una forcella per il tubo sagomato. **A richiesta i giunti possono essere forniti con estremità di tipo diverso previste nella gamma di produzione Comer Industries driveshafts.** In tal caso per effettuare l'ordine specificare la referenza della forcella che si vuole sia fornita con la forcella per il tubo sagomato.

*The codes indicated refer to joints with a grooved yoke and 1 3/8" Z6 rapid connector (Ref. 112) on one end and a yoke for the shaped tube on the other. **On request, joints can be supplied with different terminals than those available in the Comer Industries driveshafts. line.** In that case, when ordering specify the yoke reference to be supplied with the yoke for the shaped tube.*

Es.: Snodo CVJ esterno T80 ~~113~~

Ex.: Outer joint CVJ T80 ~~113~~

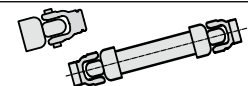

SERIE D / D SERIES

Snodo interno D120 con forcella collar
D120 inner joint with collar yoke



Ref. C27 - C25

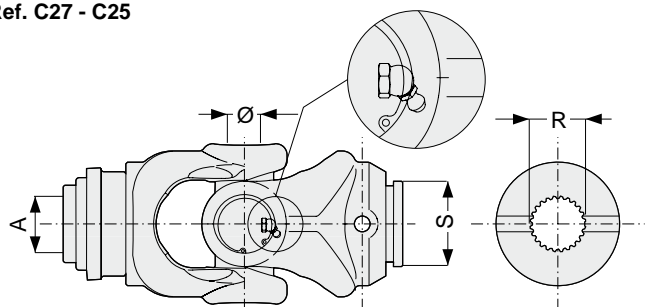

Snodo interno D120 con forcella a bulloni interferenti
D120 inner joint with interfering clamp bolts yoke



Ref. 134 - 135

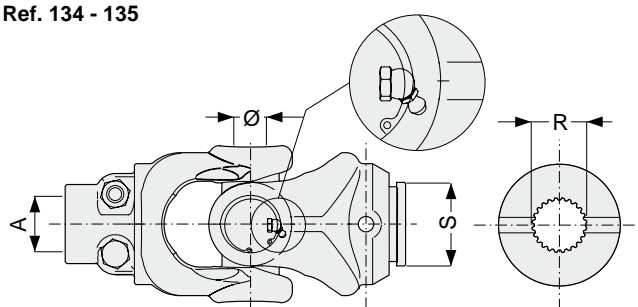

Snodo interno D120 con limitatore a bullone di trancio
D120 inner joint with shear bolt torque limiter



Ref. B34 - B35

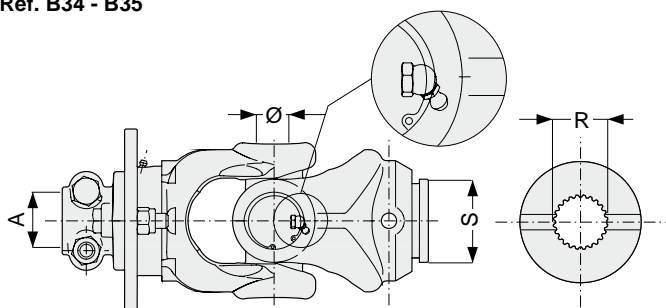

Snodo interno D120 con forcella flangia FGL
D120 inner joint with FGL flange yoke



Ref. FGL

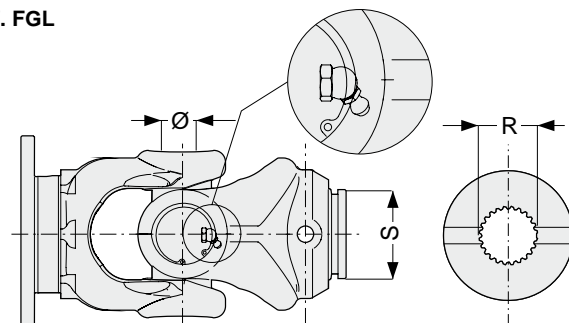

Snodi e forcelle doppie
Joint and Double Yokes

Type	Ref.	A		Ø		R	S		Code
		[mm]	[inch]	[mm]	[inch]		[mm]	[inch]	
120	C27	1 3/4"	z6	52	2 2/32"	DIN 5482 - A50x45 z24	76	2 31/32"	121.020.010.01
	C25		z20						121.020.002.01
	134	z6	121.020.017.01						
	135		z20						121.020.018.01
	B34	1 3/4"	z6						121.020.005.01
	B35		z20						121.020.004.01
	FGL	-	-						121.020.003.01



SD

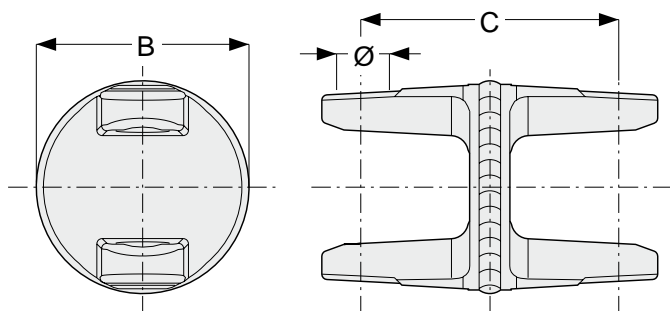

Type	Ref.	Ø		B		C		Code
		[mm]	[inch]	[mm]	[inch]	[mm]	[inch]	
10	SD10	22	55/64"	100	3 15/16"	93	3 21/32"	141.021.095.1
20	SD20	23.8	15/16"	100	3 15/16"	103	4 1/16"	151.012.350.1
40	SD40	27	1 1/16"	100	3 15/16"	125	4 59/64"	141.024.099.1
50	SD50	30.2	1 3/16"	100	3 15/16"	129	5 5/64"	141.025.095.1
60	SD60	30.2	1 3/16"	120	4 23/32"	145	5 45/64"	141.026.112.1

SH

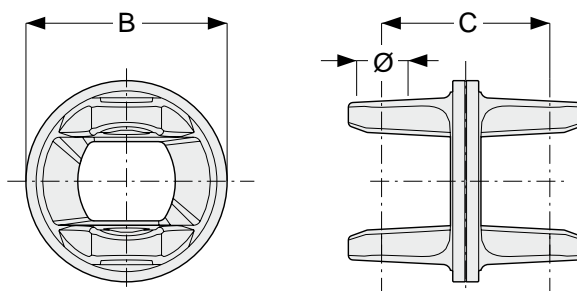

Type	Ref.	Ø		B		C		Code
		[mm]	[inch]	[mm]	[inch]	[mm]	[inch]	
10	SH10	22	55/64"	75	2 61/64"	68	2 43/64"	151.011.340.1
20	SH20	23.8	15/16"	80	3 5/32"	78	3 5/64"	151.012.115.1
40	SH40	27	1 1/16"	105	4 9/64"	90	3 35/64"	151.014.483.1
50	SH50	30.2	1 3/16"	125	4 59/64"	106	4 11/64"	151.015.386.1
60	SH60	30.2	1 3/16"	132	5 13/64"	108	4 1/4"	151.016.591.1
80	SH80	35	1 3/8"	148	5 53/64"	92	3 5/8"	151.018.562.1



SF

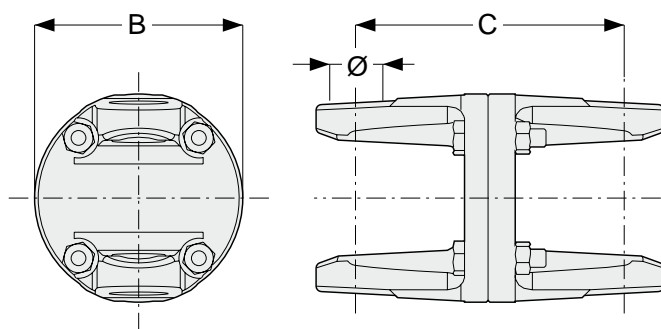

Type	Ref.	Ø		B		C		Code
		[mm]	[inch]	[mm]	[inch]	[mm]	[inch]	
10	SF10	22	55/64"	90	3 35/64"	93	3 21/32"	141.021.098.1
20	SF20	23.8	15/16"	90	3 35/64"	103	4 1/16"	141.022.084.1
40	SF40	27	1 1/16"	100	3 15/16"	125	4 59/64"	141.024.102.1
50	SF50	30.2	1 3/16"	100	3 15/16"	129	5 5/64"	141.025.098.1
60	SF60	30.2	1 3/16"	110	4 21/32"	146	5 3/4"	141.026.115.1
80	SF80	35	1 3/8"	128	5 3/64"	159	6 17/64"	141.028.084.1

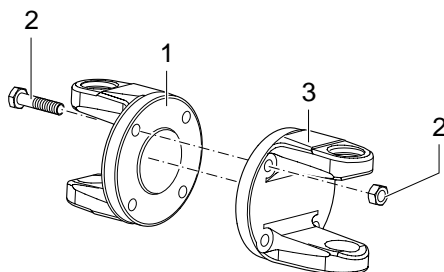

Pos.	Type	Parti di ricambio forcelle SF/ SF Yokes Spare parts		Code	Qty *
1	10	Forc. flangia maschio	Male flanged yoke	151.011.096.1	1
	20	Forc. flangia maschio	Male flanged yoke	151.012.082.1	1
	40	Forc. flangia maschio	Male flanged yoke	151.014.100.1	1
	50	Forc. flangia maschio	Male flanged yoke	151.015.096.1	1
	60	Forc. flangia maschio	Male flanged yoke	151.016.113.1	1
	80	Forc. flangia maschio	Male flanged yoke	151.018.082.1	1
2	10 - 20	Kit vite M8x1,25x35+dado	Bolt M8x1,25x35+nut	165.000.727	4
	40 - 50 - 60	Kit vite M10x1,5x45+dado	Bolt M10x1,5x45+nut	165.000.728	4
	80	Kit vite M14x1,5x45+dado	Bolt M14x1,5x45+nut	165.000.729	4
3	10	Forc. flangia femmina	Female flanged yoke	151.011.097.1	1
	20	Forc. flangia femmina	Female flanged yoke	151.012.083.1	1
	40	Forc. flangia femmina	Female flanged yoke	151.014.101.1	1
	50	Forc. flangia femmina	Female flanged yoke	151.015.097.1	1
	60	Forc. flangia femmina	Female flanged yoke	151.016.114.1	1
	80	Forc. flangia femmina	Female flanged yoke	151.018.083.1	1

* Quantità presente nella forcella SF / Quantity in the SF yoke



Questa pagina è lasciata intenzionalmente bianca
This page is intentionally left blank

PROFILI PER CARDANI

PROFILES FOR PTO DRIVESHAFTS

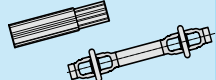
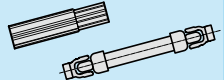
			p.
PROFILI PER CARDANI OMOCINETICI CVJ PROFILES FOR PTO DRIVESHAFTS CVJ			
Serie V	V Series		54
Serie T	T Series		55
PROFILI PER CARDANI PROFILES FOR PTO DRIVESHAFTS			
Serie V	V Series		56
Serie T	T Series		57
Serie E	E Seires		58
Serie D	D Seires		59
NOTE NOTES			60

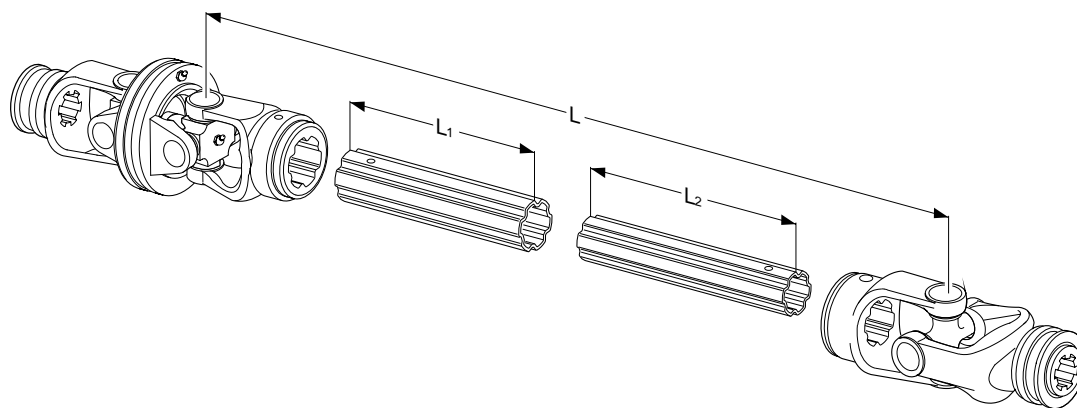
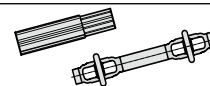

Type	20				40			
	L ₁ [mm]	Code	L ₂ [mm]	Code	L ₁ [mm]	Code	L ₂ [mm]	Code
L = 410	285	159.420.006.0700	300	159.220.006	265	159.440.006.0700	280	159.240.006
L = 460	335	159.420.001.0700	350	159.220.001	315	159.440.001.0700	330	159.240.001
L = 510	385	159.420.007.0700	400	159.220.007	365	159.440.007.0700	380	159.240.007
L = 560	435	159.420.002.0700	450	159.220.002	415	159.440.002.0700	430	159.240.002
L = 610	485	159.420.008.0700	500	159.220.008	465	159.440.008.0700	480	159.240.008
L = 660	535	159.420.003.0700	550	159.220.003	515	159.440.003.0700	530	159.240.003
L = 710	585	159.420.009.0700	600	159.220.009	565	159.440.009.0700	580	159.240.009
L = 760	635	159.420.004.0700	650	159.220.004	615	159.440.004.0700	630	159.240.004
L = 810	685	159.420.010.0700	700	159.220.010	665	159.440.010.0700	680	159.240.010
L = 860	735	159.420.005.0700	750	159.220.005	715	159.440.005.0700	730	159.240.005
L = 910	785	159.420.011.0700	800	159.220.011	765	159.440.011.0700	780	159.240.011
L = 1010	885	159.420.012.0700	900	159.220.012	865	159.440.012.0700	880	159.240.012
L = 1110	985	159.420.013.0700	1000	159.220.013	965	159.440.013.0700	980	159.240.013
L = 1210	1085	159.420.014.0700	1100	159.220.014	1065	159.440.014.0700	1080	159.240.014
L = 1310	1185	159.420.015.0700	1200	159.220.015	1165	159.440.015.0700	1180	159.240.015
L = 1410	1285	159.420.016.0700	1300	159.220.016	1265	159.440.016.0700	1280	159.240.016

Type	60				80			
	L ₁ [mm]	Code	L ₂ [mm]	Code	L ₁ [mm]	Code	L ₂ [mm]	Code
L = 410	250	152.260.501.0700	265	159.260.144	220	152.280.501.0700	235	159.280.180
L = 460	300	152.260.507.0700	315	159.260.160	270	152.280.507.0700	285	159.280.171
L = 510	350	152.260.502.0700	365	159.260.140	320	152.280.502.0700	335	159.280.137
L = 560	400	152.260.508.0700	415	159.260.137	370	152.280.508.0700	385	159.280.134
L = 610	450	152.260.503.0700	465	159.260.135	420	152.280.503.0700	435	159.280.133
L = 660	500	152.260.509.0700	515	159.260.138	470	152.280.509.0700	485	159.280.135
L = 710	550	152.260.504.0700	565	159.260.161	520	152.280.504.0700	535	159.280.179
L = 760	600	152.260.510.0700	615	159.260.124	570	152.280.510.0700	585	159.280.123
L = 810	650	152.260.505.0700	665	159.260.133	620	152.280.505.0700	635	159.280.166
L = 860	700	152.260.511.0700	715	159.260.147	670	152.280.511.0700	685	159.280.118
L = 910	750	152.260.517.0700	765	159.260.118	720	152.280.517.0700	735	159.280.143
L = 1010	850	152.260.512.0700	865	159.260.151	820	152.280.512.0700	835	159.280.161
L = 1110	950	152.260.513.0700	965	159.260.148	920	152.280.513.0700	935	159.280.181
L = 1210	1050	152.260.514.0700	1065	159.260.152	1020	152.280.514.0700	1035	159.280.168
L = 1310	1150	152.260.515.0700	1165	159.260.155	1120	152.280.515.0700	1135	159.280.182
L = 1410	1250	152.260.516.0700	1265	159.260.150	1220	152.280.516.0700	1235	159.280.183

I profili 20 e 40 sono trattati NITREG.
I profili 60 e 80 sono rivestiti RILSAN.

Profiles type 20 and 40 have NITREG treatment.
Inner profiles type 60 and 80 coated with RILSAN treatment.

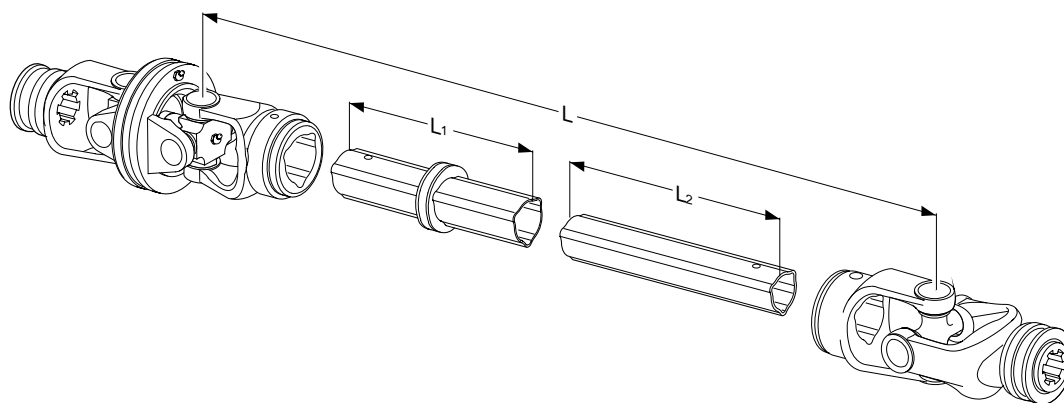
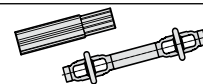

Type	20				40			
	L ₁ [mm]	Code	L ₂ [mm]	Code	L ₁ [mm]	Code	L ₂ [mm]	Code
L = 410	285	152.120.501.7800	300	159.120.248	265	152.140.522.7800	280	159.140.542
L = 460	335	152.120.502.7800	350	159.120.249	315	152.140.546.7800	330	159.140.579
L = 510	385	152.120.503.7800	400	159.120.250	365	152.140.521.7800	380	159.140.539
L = 560	435	152.120.504.7800	450	159.120.243	415	152.140.537.7800	430	159.140.576
L = 610	485	152.120.505.7800	500	159.120.251	465	152.140.523.7800	480	159.140.546
L = 660	535	152.120.506.7800	550	159.120.252	515	152.140.510.7800	530	159.140.511
L = 710	585	152.120.507.7800	600	159.120.253	565	152.140.517.7800	580	159.140.535
L = 760	635	152.120.508.7800	650	159.120.241	615	152.140.519.7800	630	159.140.537
L = 810	685	152.120.509.7800	700	159.120.247	665	152.140.513.7800	680	159.140.526
L = 860	735	152.120.510.7800	750	159.120.255	715	152.140.520.7800	730	159.140.538
L = 910	785	152.120.511.7800	800	159.120.256	765	152.140.518.7800	780	159.140.536
L = 1010	885	152.120.512.7800	900	159.120.257	865	152.140.512.7800	880	159.140.522
L = 1110	985	152.120.513.7800	1000	159.120.258	965	152.140.515.7800	980	159.140.528
L = 1210	1085	152.120.514.7800	1100	159.120.259	1065	152.140.514.7800	1080	159.140.527
L = 1310	1185	152.120.515.7800	1200	159.120.260	1165	152.140.516.7800	1180	159.140.532
L = 1410	1285	152.120.526.7800	1300	159.120.261	1265	152.140.544.7800	1280	159.140.577

Type	60				80			
	L ₁ [mm]	Code	L ₂ [mm]	Code	L ₁ [mm]	Code	L ₂ [mm]	Code
L = 410	250	152.160.585.7800	265	159.160.898	220	152.180.501.7800	235	159.190.027
L = 460	300	152.160.537.7800	315	159.160.837	270	152.180.502.7800	285	159.190.028
L = 510	350	152.160.561.7800	365	159.160.865	320	152.180.503.7800	335	159.190.029
L = 560	400	152.160.551.7800	415	159.160.875	370	152.180.504.7800	385	159.190.030
L = 610	450	152.160.540.7800	465	159.160.822	420	152.180.505.7800	435	159.190.031
L = 660	500	152.160.538.7800	515	159.160.836	470	152.180.506.7800	485	159.190.032
L = 710	550	152.160.532.7800	565	159.160.826	520	152.180.507.7800	535	159.190.033
L = 760	600	152.160.539.7800	615	159.160.356	570	152.180.508.7800	585	159.190.034
L = 810	650	152.160.542.7800	665	159.160.840	620	152.180.509.7800	635	159.190.035
L = 860	700	152.160.533.7800	715	159.160.832	670	152.180.510.7800	685	159.190.036
L = 910	750	152.160.543.7800	765	159.160.841	720	152.180.511.7800	735	159.190.037
L = 1010	850	152.160.544.7800	865	159.160.842	820	152.180.512.7800	835	159.190.038
L = 1110	950	152.160.536.7800	965	159.160.855	920	152.180.513.7800	935	159.190.039
L = 1210	1050	152.160.535.7800	1065	159.160.834	1020	152.180.514.7800	1035	159.190.040
L = 1310	1150	152.160.545.7800	1165	159.160.843	1120	152.180.515.7800	1135	159.190.041
L = 1410	1250	152.160.547.7800	1265	159.160.847	1220	152.180.538.7800	1235	159.190.529

I profili interni sono rivestiti **RILSAN**.

Inner profiles coated with **RILSAN** treatment.

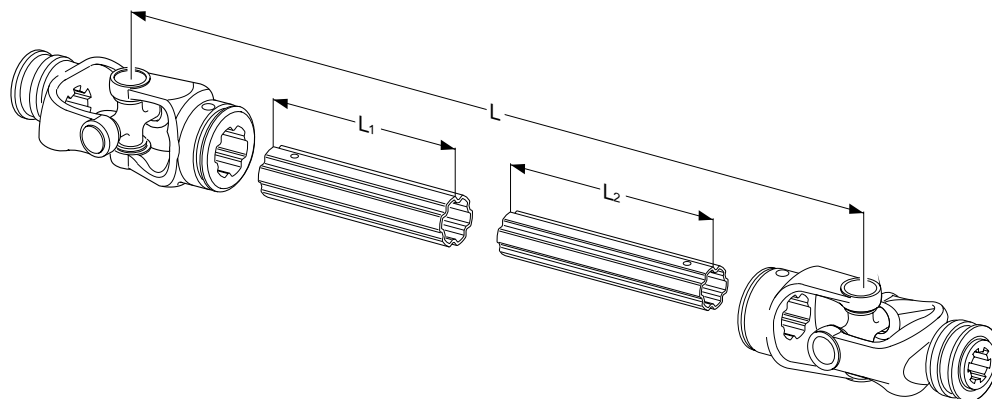
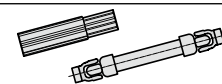

Type	20				40				50			
	L ₁ [mm]	Code	L ₂ [mm]	Code	L ₁ [mm]	Code	L ₂ [mm]	Code	L ₁ [mm]	Code	L ₂ [mm]	Code
L = 410	285	152.220.006.0700	300	153.220.006	265	152.240.006.0700	280	153.240.006	260	152.260.259.0700	275	153.260.173
L = 460	335	152.220.001.0700	350	153.220.001	315	152.240.001.0700	330	153.240.001	310	152.260.260.0700	325	153.260.174
L = 510	385	152.220.007.0700	400	153.220.007	365	152.240.007.0700	380	153.240.007	360	152.260.234.0700	375	153.260.147
L = 560	435	152.220.002.0700	450	153.220.002	415	152.240.002.0700	430	153.240.002	410	152.260.261.0700	425	153.260.175
L = 610	485	152.220.008.0700	500	153.220.008	465	152.240.008.0700	480	153.240.008	460	152.260.252.0700	475	153.260.166
L = 660	535	152.220.003.0700	550	153.220.003	515	152.240.003.0700	530	153.240.003	510	152.260.251.0700	525	153.260.165
L = 710	585	152.220.009.0700	600	153.220.009	565	152.240.009.0700	580	153.240.009	560	152.260.262.0700	575	153.260.176
L = 760	635	152.220.004.0700	650	153.220.004	615	152.240.004.0700	630	153.240.004	610	152.260.257.0700	625	153.260.171
L = 810	685	152.220.010.0700	700	153.220.010	665	152.240.010.0700	680	153.240.010	660	152.260.263.0700	675	153.260.177
L = 860	735	152.220.005.0700	750	153.220.005	715	152.240.005.0700	730	153.240.005	710	152.260.235.0700	725	153.260.148
L = 910	785	152.220.011.0700	800	153.220.011	765	152.240.011.0700	780	153.240.011	760	152.260.264.0700	775	153.260.178
L = 1010	885	152.220.012.0700	900	153.220.012	865	152.240.012.0700	880	153.240.012	860	152.260.233.0700	875	153.260.145
L = 1110	985	152.220.013.0700	1000	153.220.013	965	152.240.013.0700	980	153.240.013	960	152.260.265.0700	975	153.260.180
L = 1210	1085	152.220.014.0700	1100	153.220.014	1065	152.240.014.0700	1080	153.240.014	1060	152.260.266.0700	1075	153.260.181
L = 1310	1185	152.220.015.0700	1200	153.220.015	1165	152.240.015.0700	1180	153.240.015	1160	152.260.267.0700	1175	153.260.182
L = 1410	1285	152.220.016.0700	1300	153.220.016	1265	152.240.016.0700	1280	153.240.016	1260	152.260.268.0700	1275	153.260.183

Type	60				80				90			
	L ₁ [mm]	Code	L ₂ [mm]	Code	L ₁ [mm]	Code	L ₂ [mm]	Code	L ₁ [mm]	Code	L ₂ [mm]	Code
L = 410	250	152.260.201.0700	265	153.260.101	220	152.280.201.0700	235	153.280.101	215	152.280.245.0700	230	159.280.174
L = 460	300	152.260.207.0700	315	153.260.107	270	152.280.207.0700	285	153.280.107	265	152.280.239.0700	280	159.280.150
L = 510	350	152.260.202.0700	365	153.260.102	320	152.280.202.0700	335	153.280.102	315	152.280.228.0700	330	159.280.164
L = 560	400	152.260.208.0700	415	153.260.108	370	152.280.208.0700	385	153.280.108	365	152.280.236.0700	380	159.280.151
L = 610	450	152.260.203.0700	465	153.260.103	420	152.280.203.0700	435	153.280.103	415	152.280.240.0700	430	159.280.152
L = 660	500	152.260.209.0700	515	153.260.109	470	152.280.209.0700	485	153.280.109	465	152.280.231.0700	480	159.280.149
L = 710	550	152.260.204.0700	565	153.260.104	520	152.280.204.0700	535	153.280.104	515	152.280.250.0700	530	159.280.159
L = 760	600	152.260.210.0700	615	153.260.110	570	152.280.210.0700	585	153.280.110	565	152.280.264.0700	580	159.280.175
L = 810	650	152.260.205.0700	665	153.260.105	620	152.280.205.0700	635	153.280.105	615	152.280.265.0700	630	159.280.170
L = 860	700	152.260.211.0700	715	153.260.111	670	152.280.211.0700	685	153.280.111	665	152.280.266.0700	680	159.280.156
L = 910	750	152.260.217.0700	765	153.260.117	720	152.280.217.0700	735	153.280.117	715	152.280.251.0700	730	159.280.160
L = 1010	850	152.260.212.0700	865	153.260.112	820	152.280.212.0700	835	153.280.112	815	152.280.242.0700	830	159.280.157
L = 1110	950	152.260.213.0700	965	153.260.113	920	152.280.213.0700	935	153.280.113	915	152.280.267.0700	930	159.280.176
L = 1210	1050	152.260.214.0700	1065	153.260.114	1020	152.280.214.0700	1035	153.280.114	1015	152.280.232.0700	1030	159.280.177
L = 1310	1150	152.260.215.0700	1165	153.260.115	1120	152.280.215.0700	1135	153.280.115	1115	152.280.259.0700	1130	159.280.167
L = 1410	1250	152.260.216.0700	1265	153.260.116	1220	152.280.216.0700	1235	153.280.116	1215	152.280.268.0700	1230	159.280.178

I profili 90 interni sono cementati.

Inner profiles type 90 has hardness treatment

PROFILI SERIE T SERIES T PROFILES

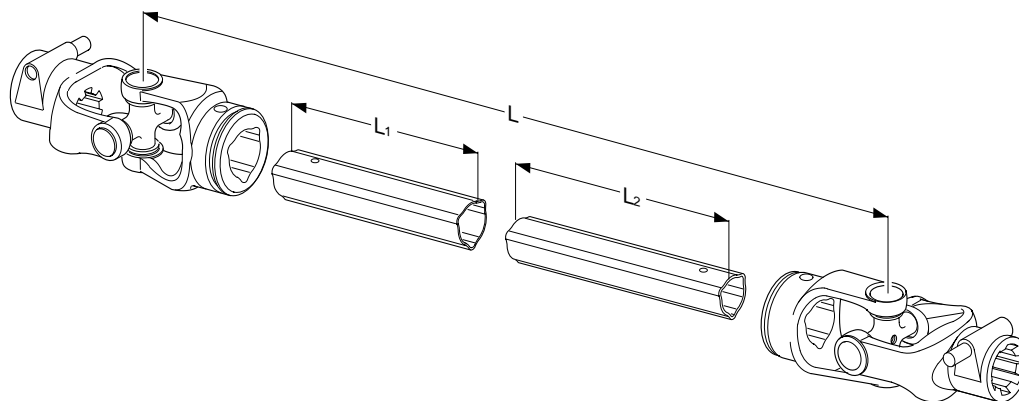
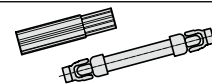

Type	10				20				40				50			
	L ₁ [mm]	Code	L ₂ [mm]	Code	L ₁ [mm]	Code	L ₂ [mm]	Code	L ₁ [mm]	Code	L ₂ [mm]	Code	L ₁ [mm]	Code	L ₂ [mm]	Code
L = 410	290	152.110.206.0700	305	153.110.106	285	152.120.206.0700	300	153.120.106	265	152.140.206.0700	280	153.140.106	260	152.150.206.0700	275	153.150.106
L = 460	340	152.110.346.0700	355	153.110.192	335	152.120.323.0700	350	153.120.216	315	152.140.278.0700	330	153.140.184	310	152.150.343.0700	325	153.150.345
L = 510	390	152.110.207.0700	405	153.110.107	385	152.120.207.0700	400	153.120.107	365	152.140.207.0700	380	153.140.107	360	152.150.207.0700	375	153.150.107
L = 560	440	152.110.243.0700	455	153.110.137	435	152.120.289.0700	450	153.120.181	415	152.140.280.0700	430	153.140.188	410	152.150.344.0700	425	153.150.346
L = 610	490	152.110.208.0700	505	153.110.108	485	152.120.208.0700	500	153.120.108	465	152.140.208.0700	480	153.140.108	460	152.150.208.0700	475	153.150.108
L = 660	540	152.110.344.0700	555	153.110.186	535	152.120.325.0700	550	153.120.223	515	152.140.292.0700	530	153.140.200	510	152.150.329.0700	525	153.150.347
L = 710	590	152.110.209.0700	605	153.110.109	585	152.120.209.0700	600	153.120.109	565	152.140.209.0700	580	153.140.109	560	152.150.209.0700	575	153.150.109
L = 760	640	152.110.219.0700	655	153.110.232	635	152.120.262.0700	650	153.120.160	615	152.140.296.0700	630	153.140.401	610	152.150.345.0700	625	153.150.348
L = 810	690	152.110.210.0700	705	153.110.110	685	152.120.210.0700	700	153.120.110	665	152.140.210.0700	680	153.140.110	660	152.150.210.0700	675	153.150.110
L = 860	740	152.110.347.0700	755	153.110.189	735	152.120.326.0700	750	153.120.224	715	152.140.258.0700	730	153.140.165	710	152.150.337.0700	725	153.150.349
L = 910	790	152.110.211.0700	805	153.110.111	785	152.120.211.0700	800	153.120.111	765	152.140.211.0700	780	153.140.111	760	152.150.211.0700	775	153.150.111
L = 1010	890	152.110.212.0700	905	153.110.112	885	152.120.212.0700	900	153.120.112	865	152.140.212.0700	880	153.140.112	860	152.150.212.0700	875	153.150.112
L = 1110	990	152.110.213.0700	1005	153.110.113	985	152.120.213.0700	1000	153.120.113	965	152.140.213.0700	980	153.140.113	960	152.150.213.0700	975	153.150.113
L = 1210	1090	152.110.214.0700	1105	153.110.114	1085	152.120.214.0700	1100	153.120.114	1065	152.140.214.0700	1080	153.140.114	1060	152.150.214.0700	1075	153.150.114
L = 1310	1190	152.110.215.0700	1205	153.110.115	1185	152.120.215.0700	1200	153.120.115	1165	152.140.215.0700	1080	153.140.115	1160	152.150.215.0700	1175	153.150.115
L = 1410	1290	152.110.339.0700	1305	153.110.230	1285	152.120.335.0700	1300	153.120.239	1265	152.140.662.0700	1280	153.140.519	1260	152.150.340.0700	1275	153.150.342

Type	60				80				90			
	L ₁ [mm]	Code	L ₂ [mm]	Code	L ₁ [mm]	Code	L ₂ [mm]	Code	L ₁ [mm]	Code	L ₂ [mm]	Code
L = 410	250	152.160.476.0700	265	153.160.823	220	152.198.136.0700	235	153.190.001	215	152.198.501.0700	230	153.190.501
L = 460	300	152.160.207.0700	315	153.160.107	270	152.198.137.0700	285	153.190.002	265	152.198.502.0700	280	153.190.502
L = 510	350	152.180.298.0700	365	153.160.148	320	152.198.138.0700	335	153.190.003	315	152.198.503.0700	330	153.190.503
L = 560	400	152.160.208.0700	415	153.160.108	370	152.198.139.0700	385	153.190.004	365	152.198.504.0700	380	153.190.504
L = 610	450	152.160.475.0700	465	153.160.150	420	152.198.140.0700	435	153.190.005	415	152.198.505.0700	430	153.190.505
L = 660	500	152.160.209.0700	515	153.160.109	470	152.198.117.0700	485	153.190.006	465	152.198.506.0700	480	153.190.506
L = 710	550	152.160.473.0700	565	153.160.174	520	152.198.141.0700	535	153.190.007	515	152.198.507.0700	530	153.190.507
L = 760	600	152.160.210.0700	615	153.160.110	570	152.198.142.0700	585	153.190.008	565	152.198.508.0700	580	153.190.508
L = 810	650	152.160.472.0700	665	153.160.738	620	152.198.143.0700	635	153.190.009	615	152.198.509.0700	630	153.190.509
L = 860	700	152.160.211.0700	715	153.160.111	670	152.198.144.0700	685	153.190.010	665	152.198.510.0700	680	153.190.510
L = 910	750	152.160.477.0700	765	153.160.798	720	152.198.135.0700	735	153.190.011	715	152.198.511.0700	730	153.190.511
L = 1010	850	152.160.212.0700	865	153.160.112	820	152.198.145.0700	835	153.190.012	815	152.198.512.0700	830	153.190.512
L = 1110	950	152.160.213.0700	965	153.160.113	920	152.198.146.0700	935	153.190.013	915	152.198.513.0700	930	153.190.513
L = 1210	1050	152.160.214.0700	1065	153.160.114	1020	152.198.147.0700	1035	153.190.014	1015	152.198.514.0700	1030	153.190.514
L = 1310	1150	152.160.215.0700	1165	153.160.115	1120	152.198.131.0700	1135	153.190.015	1115	152.198.515.0700	1130	153.190.515
L = 1410	1250	152.160.461.0700	1265	153.150.334	1220	152.198.149.0700	1235	153.190.018	1215	152.198.538.0700	1230	153.190.523

Profili per cardani
Profiles for PTO driveshafts

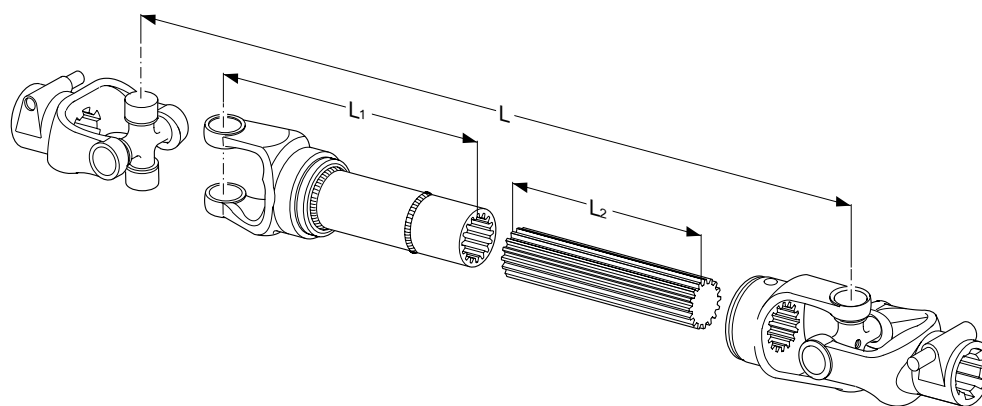
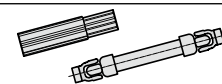

Type	40				50				60			
	L ₁ [mm]	Code	L ₂ [mm]	Code	L ₁ [mm]	Code	L ₂ [mm]	Code	L ₁ [mm]	Code	L ₂ [mm]	Code
L = 410	320	122.240.806.1	280	155.140.606	315	122.250.806.1	275	155.150.606	305	122.260.825.1	265	155.150.654
L = 460	370	122.240.801.1	330	155.140.601	365	122.250.818.1	325	155.150.624	355	122.260.807.1	315	155.160.607
L = 510	420	122.240.807.1	380	155.140.607	415	122.250.807.1	375	155.150.607	405	122.260.826.1	365	155.150.634
L = 560	470	122.240.802.1	430	155.140.602	465	122.250.819.1	425	155.150.625	455	122.260.808.1	415	155.160.608
L = 610	520	122.240.808.1	480	155.140.608	515	122.250.808.1	475	155.150.608	505	122.260.827.1	465	155.150.645
L = 660	570	122.240.803.1	530	155.140.603	565	122.250.820.1	525	155.150.626	555	122.260.809.1	515	155.160.609
L = 710	620	122.240.809.1	580	155.140.609	615	122.250.809.1	575	155.150.609	605	122.260.828.1	565	155.150.679
L = 760	670	122.240.804.1	630	155.140.604	665	122.250.821.1	625	155.150.627	655	122.260.810.1	615	155.160.610
L = 810	720	122.240.810.1	680	155.140.610	715	122.250.810.1	675	155.150.610	705	122.260.829.1	665	155.150.685
L = 860	770	122.240.805.1	730	155.140.605	765	122.250.822.1	725	155.150.628	755	122.260.811.1	715	155.150.611
L = 910	820	122.240.811.1	780	155.140.611	815	122.250.811.1	775	155.160.611	805	122.260.003.1	765	155.150.715
L = 1010	920	122.240.812.1	780	155.140.611	915	122.250.812.1	775	155.160.611	905	122.260.812.1	765	155.150.715
L = 1110	1020	122.240.813.1	780	155.140.611	1015	122.250.813.1	775	155.160.611	1005	122.260.813.1	765	155.150.715
L = 1210	1120	122.240.814.1	780	155.140.611	1115	122.250.814.1	775	155.160.611	1105	122.260.814.1	765	155.150.715
L = 1310	1220	122.240.815.1	780	155.140.611	1215	122.250.815.1	775	155.160.611	1205	122.260.815.1	765	155.150.715
L = 1410	1320	122.240.818.1	780	155.140.611	1315	122.250.816.1	775	155.160.611	1305	122.260.816.1	765	155.150.715

Type	80				90			
	L ₁ [mm]	Code	L ₂ [mm]	Code	L ₁ [mm]	Code	L ₂ [mm]	Code
L = 410	295	122.280.966.1	235	155.170.677	285	122.290.801.1	230	155.190.601
L = 460	345	122.280.970.1	285	155.180.607	335	122.290.807.1	280	155.190.607
L = 510	395	122.280.965.1	335	155.170.633	385	122.290.802.1	330	155.190.602
L = 560	445	122.280.963.1	385	155.180.608	435	122.290.808.1	380	155.190.608
L = 610	495	122.280.967.1	435	155.170.635	485	122.290.803.1	430	155.190.603
L = 660	545	122.280.964.1	485	155.180.609	535	122.290.809.1	480	155.190.609
L = 710	595	122.280.968.1	535	155.170.636	585	122.290.804.1	530	155.190.604
L = 760	645	122.280.971.1	585	155.180.610	635	122.290.810.1	580	155.190.610
L = 810	695	122.280.969.1	635	155.170.647	685	122.290.805.1	630	155.190.605
L = 860	745	122.280.972.1	685	155.180.611	735	122.290.811.1	680	155.190.611
L = 910	795	122.280.973.1	735	155.170.688	785	122.290.806.1	730	155.190.617
L = 1010	895	122.480.011.1	735	155.170.688	885	122.290.812.1	730	155.190.617
L = 1110	995	122.480.006.1	735	155.170.688	985	122.290.813.1	730	155.190.617
L = 1210	1095	122.480.017.1	735	155.170.688	1085	122.290.814.1	730	155.190.617
L = 1310	1195	122.480.018.1	735	155.170.688	1185	122.290.815.1	730	155.190.617
L = 1410	1295	122.480.019.1	735	155.170.688	1285	122.490.002.1	730	155.190.617

I profili scanalati sono forniti alla lunghezza richiesta, con foro per spina elastica e trattati termicamente

Splined profiles are supplied with the requested length, with pin hole yoke and with heat treatment.

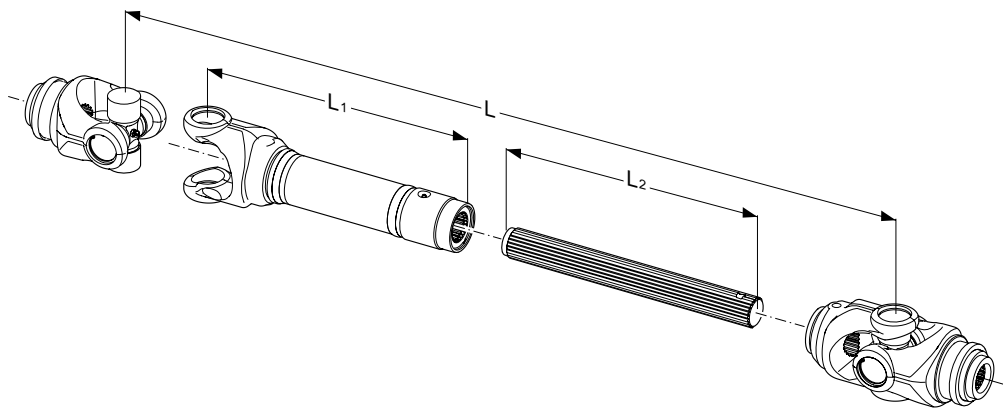
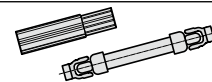

Type	120			
	L ₁ [mm]	Code	L ₂ [mm]	Code
L = 460	316	122.120.001.1	300	155.100.011
L = 510	366	122.120.002.1	350	155.100.012
L = 560	416	122.120.003.1	400	155.100.006
L = 610	466	122.120.004.1	450	155.100.001
L = 660	516	122.120.005.1	500	155.100.004
L = 710	566	122.120.006.1	550	155.100.005
L = 760	616	122.120.007.1	600	155.100.013
L = 810	666	122.120.008.1	650	155.100.014
L = 860	716	122.120.009.1	700	155.100.007
L = 910	766	122.120.010.1	750	155.100.002
L = 1010	866	122.120.011.1	850	155.100.009
L = 1110	966	122.120.012.1	900	155.100.008
L = 1210	1066	122.120.013.1	900	155.100.008
L = 1310	1166	122.120.014.1	900	155.100.008
L = 1410	1266	122.120.015.1	900	155.100.008

Profili per cardani
Profiles for PTO driveshafts

I profili scanalati sono forniti alla lunghezza richiesta, con foro per spina elastica e trattati termicamente.

Forcelle tubo esterna fornita completa di ingrassatore e parapolvere.

Splined profiles are supplied with the requested length, with pin hole yoke and with heat treatment.

Outer tube yoke fitted with grease nipple and dust seal

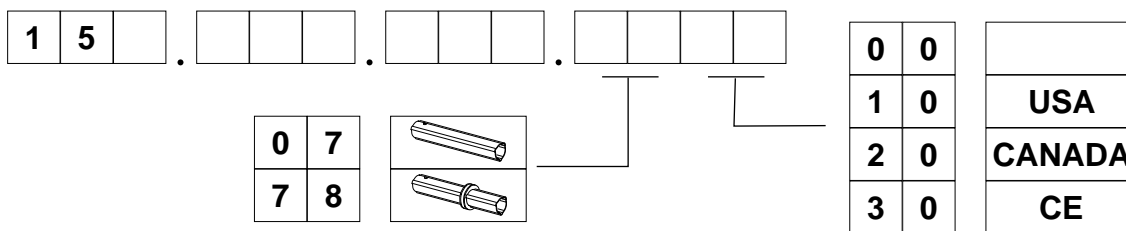
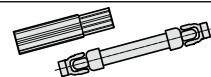

Barre profili serie V - Profiles Bars V Series

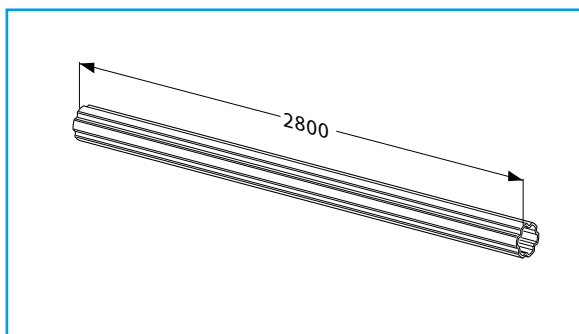

Type	Profilo esterno Outer profile		Profilo interno Inner Profile
	Standard Code	con trattamento RILSAN with RILSAN treatment Code	Code
20	191.120.800	-	191.120.700
40	191.140.800	-	191.140.700
50	191.160.800	191.160.850	191.160.700
60	191.160.800	191.160.850	191.160.700
80	191.190.800	191.190.850	191.190.700
90	191.190.800	191.190.850	-

Barre profili serie T - Profiles Bars T Series

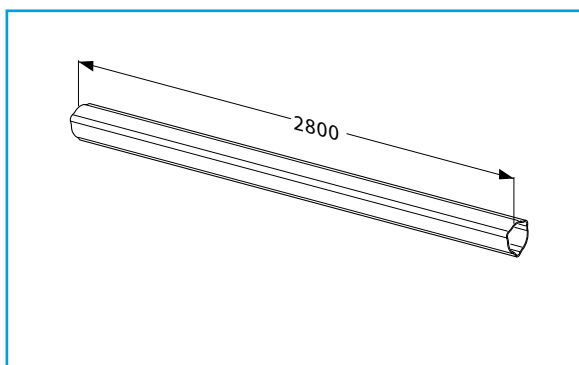

Type	Profilo esterno Outer profile		Profilo interno Inner Profile
	Standard Code	con trattamento RILSAN with RILSAN treatment Code	Code
10	191.110.200	-	191.110.100
20	191.120.200	191.120.500	191.120.100
40	191.130.200	191.140.500	191.140.100
50	191.150.200	-	191.150.100
60	191.160.200	191.160.500	191.150.100
80	191.198.850	191.180.500	191.190.300
90	191.198.850	191.180.500	191.190.300

Tutte le misure, ove non specificatamente indicato, sono espresse in millimetri.

I profili esterni o le forcelle tubo a misura sono fornibili a richiesta, con applicate decalcomanie tipo:

- CE - USA - CANADA -

A richiesta sono disponibili profili interni a misura, rivestiti **RILSAN** o con trattamento indurente.

Il profilo interno rivestito **RILSAN** necessita del suo profilo esterno specifico. Per tubi con trattamenti termici contattare il nostro Ufficio Tecnico.

All sizes, unless otherwise specified, are expressed in millimetres.

The outer profiles or fitted tube yokes can be supplied on request with the following decals included:

- CE - USA - CANADA -

RILSAN coated or hardened fitted inner profiles are available on request.

The **RILSAN** coated inner profile requires its own specific outer profile. For tubes with heat treatments contact our Technical Department.

DISPOSITIVI DI SICUREZZA INTEGRALI INTEGRAL SAFETY DEVICES

		p.
	PROGRAMMA DI PRODUZIONE PRODUCTION PROGRAM	62
B	LIMITATORE A BULLONE DI TRANCIO SHEAR BOLT TORQUE LIMITER	66
	Caratteristiche <i>Features</i>	66
	Parti di ricambio <i>Spare Parts</i>	67
M	LIMITATORE A NOTTOLINI BIDIREZIONALE BI-DIRECTIONAL RATCHET CLUTCH TORQUE LIMITER	68
	Caratteristiche <i>Features</i>	68
	Parti di ricambio <i>Spare Parts</i>	69
R	RUOTA LIBERA OVERRUNNING CLUTCH	70
	Caratteristiche <i>Features</i>	70
	Parti di ricambio <i>Spare Parts</i>	71
F	FRIZIONE A DISCHI MULTIPLI DISC CLUTCH TORQUE LIMITER	72
	Caratteristiche <i>Features</i>	72
	Parti di ricambio <i>Spare Parts</i>	74
W	FRIZIONE CHIUSA A DISCHI MULTIPLI CLOSED DISC CLUTCH TORQUE LIMITER	78
	Caratteristiche <i>Features</i>	78
	Parti di ricambio <i>Spare Parts</i>	80
RB	LIMITATORE A BULLONE DI TRANCIO CON RUOTA LIBERA SHEAR BOLT TORQUE LIMITER WITH OVERRUNNING CLUTCH	83
	Caratteristiche <i>Features</i>	83
	Parti di ricambio <i>Spare Parts</i>	84
RF	FRIZIONE A DISCHI MULTIPLI CON RUOTA LIBERA DISC CLUTCH TORQUE LIMITER WITH OVERRUNNING CLUTCH	85
	Caratteristiche <i>Features</i>	85
	Parti di ricambio <i>Spare Parts</i>	87
RW	FRIZIONE CHIUSA CON RUOTA LIBERA CLOSED DISC CLUTCH TORQUE LIMITER WITH OVERRUNNING CLUTCH	91
	Caratteristiche <i>Features</i>	91
	Parti di ricambio <i>Spare Parts</i>	93
FM MM RM	DISPOSITIVI CON ALBERO MASCHIO DEVICES WITH MALE SHAFT	95

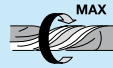

Type	Ref.							P.	
			B	C	D	Nm	in. lb.		
B	10	B02	mm	120	95	19	650	5700	66
		B03	inch	4 23/32"	3 47/64"	3/4"			
	20	B02	mm	120	97	19	900	7950	
		B03	inch	4 23/32"	3 13/16"	3/4"			
	40	B02	mm	134	118	19	1700	15000	
		B03	inch	5 9/32"	4 41/64"	3/4"			
	50	B02	mm	134	118	19	2100	18500	
B03		inch	5 9/32"	4 41/64"	3/4"				
60	B02-B03	mm	162	137	22	2500	22100		
	B04-B05	inch	6 3/8"	5 25/64"	7/8"				
80	B02-B03	mm	162	146	22	3500	30900		
	B04-B05	inch	6 3/8"	5 3/4"	7/8"				
90	B02-B03	mm	162	152	22	4000	35400		
	B04-B05	inch	6 3/8"	6"	7/8"				

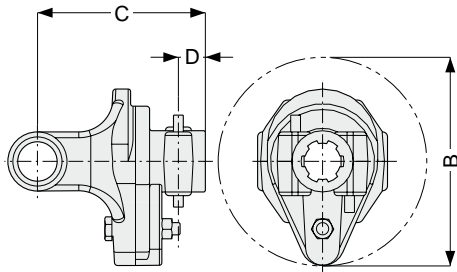

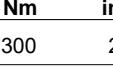
Type	Ref.							P.			
			B	C	D	Nm	in. lb.				
M	10	M14	mm	100	121	26	300	2650	68		
		M15	inch	3 5/16"	4 49/64"	1 1/32"					
		M24	mm	100	141	26					
		M25	inch	3 5/16"	5 35/64"	1 1/32"					
	20	M14	mm	100	126	26	300	2650			
		M15	inch	3 5/16"	4 61/64"	1 1/32"					
		M24	mm	100	146	26					
		M25	inch	3 5/16"	5 3/4"	1 1/32"					
	40	M34	mm	100	166	26	600	5300			
		M35	inch	3 5/16"	6 17/32"	1 1/32"					
		M24	mm	100	157	26				900	7950
		M25	inch	3 5/16"	6 3/16"	1 1/32"					
M34	mm	100	177	26							
M35	inch	3 5/16"	6 31/32"	1 1/32"							
50	M44	mm	100	197	26	1200	10600				
	M45	inch	3 5/16"	7 3/4"	1 1/32"						
	M24	mm	100	159	26			600	5300		
	M25	inch	3 5/16"	6 17/64"	1 1/32"						
M34	mm	100	179	26							
M35	inch	3 5/16"	7 3/64"	1 1/32"							
60	M44	mm	100	199	26	1200	10600				
	M45	inch	3 5/16"	7 53/64"	1 1/32"						
	M34	mm	115	187	26			900	7950		
	M35	inch	4 17/32"	7 23/64"	1 1/32"						
M44	mm	115	207	26							
M45	inch	4 17/32"	8 5/32"	1 1/32"							

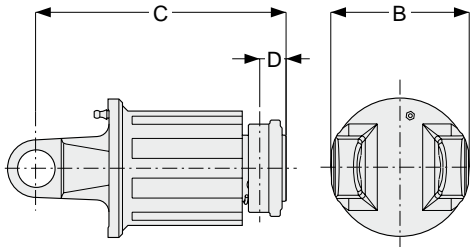

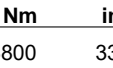
Type	Ref.							P.	
			B	C	D	Nm	in. lb.		
R R12-R13	10	R12	mm	96	141	26	3800	33630	70
		R13	inch	3 25/32"	5 35/64"	1 1/32"			
	20	R12	mm	96	146	26	3800	33630	
		R13	inch	3 25/32"	5 3/4"	1 1/32"			
	40	R12	mm	96	157	26	3800	33630	
		R13	inch	3 25/32"	6 3/16"	1 1/32"			
50	R12	mm	100	159	26	3800	33630		
	R13	inch	3 15/16"	6 17/64"	1 1/32"				
60	R12	mm	115	167	26	3800	33630		
	R13	inch	4 17/32"	6 37/64"	1 1/32"				
80	R12	mm	127	176	26	3800	33630		
	R13	inch	5"	6 59/64"	1 1/32"				

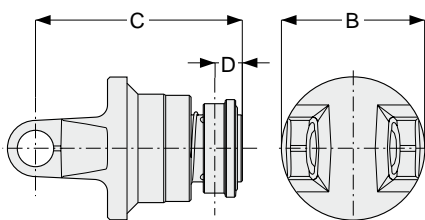



Type	Ref.							P.	
			B	C	D	Nm	in. lb.		
R R14-R15	40	R14	mm	140	157	28	3800	33630	70
		R15	inch	5 33/64"	6 3/16"	1 7/64"			
	50	R14	mm	140	159	28	3800	33630	
		R15	inch	5 33/64"	6 17/64"	1 7/64"			
60	R14	mm	140	167	28	3800	33630		
	R15	inch	5 33/64"	6 37/64"	1 7/64"				
80	R14	mm	140	176	28	3800	33630		
	R15	inch	5 33/64"	6 59/64"	1 7/64"				

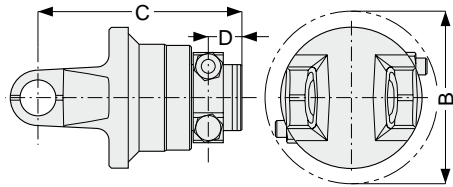

Type	Ref.							P.		
			B	C	D	Nm	in. lb.			
F	20	F02	mm	153	120	22	650	5750	72	
		F03	inch	6 1/32"	4 23/32"	7/8"				
		F04	mm	153	144	26				
	40	F04	F05	inch	6 1/32"	5 43/64"	1 1/32"	900		7950
			F05	mm	153	157	26			
F12		F13	mm	180	135	19	900	7950		
		F13	inch	7 3/32"	5 5/16"	3/4"				
		F13	mm	195	146	26				
50	F22-F23	F24-F25	inch	7 43/64"	5 3/4"	1 1/32"	1200	10600		
		F24-F25	mm	195	146	26				
	F42-F43	F44-F45	inch	7 43/64"	6 1/8"	1 1/32"	1600	14150		
		F44-F45	mm	195	156	26				
60	F22-F23	F24-F25	mm	180	135	19	900	7950		
		F24-F25	inch	7 3/32"	5 5/16"	3/4"				
	F24-F25	mm	195	146	26					
80	F22-F23	F24-F25	mm	195	159	26	1200	10600		
		F24-F25	inch	7 43/64"	6 17/64"	1 1/32"				
	F42-F43	mm	195	169	26					
90	F42-F43	F44-F45	inch	7 43/64"	6 21/32"	1 1/32"	2000	17700		
		F44-F45	mm	195	169	26				

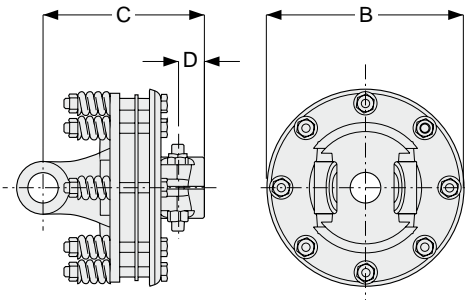

Type	Ref.							P.	
			B	C	D	Nm	in. lb.		
W W22-W23-W42-W43	20	W22	mm	173	133.5	26	600	5300	78
		W23	inch	6 13/16"	5 1/4"	1 1/32"			
	40	W22	mm	173	140	26	600+900	5300+7950	
		W23	inch	6 13/16"	5 33/64"	1 1/32"			
50	W22	W23	mm	173	143.5	26	900	7950	
		W23	inch	6 13/16"	5 21/32"	1 1/32"			
	W42	W43	mm	173	158.5	26	1100	9700	
		W43	inch	6 13/16"	6 15/64"	1 1/32"			
60	W22	W23	mm	173	150.5	26	900	7950	
		W23	inch	6 13/16"	5 59/64"	1 1/32"			
	W42	mm	173	165.5	26				
W43	W43	inch	6 13/16"	6 33/64"	1 1/32"	1100+1500	9700+13250		
	80	W42	mm	173	173.5	26	1100+1800	9700+15900	
W43		inch	6 13/16"	6 33/64"	1 1/32"				

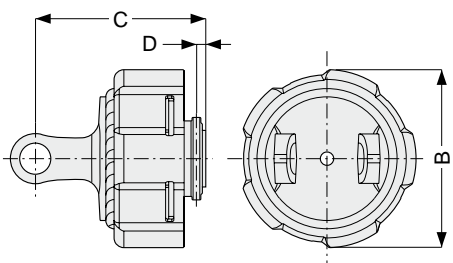



Tutti i dispositivi di sicurezza devono essere montati lato macchina operatrice. All safety devices must be installed on the implement side of the PTO driveshaft.

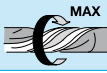
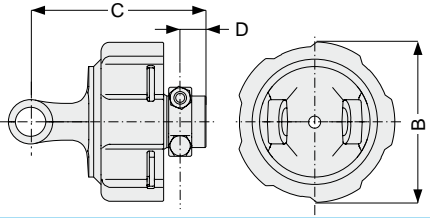
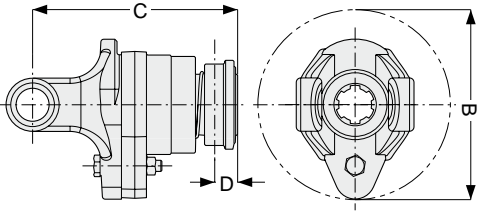
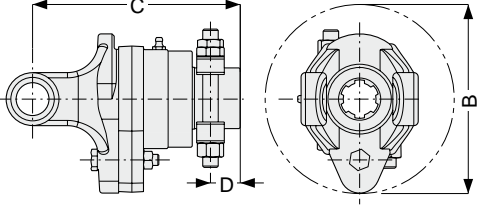

		Type	Ref.			P.			
W W44-W45 	50	W44 W45	mm	B 173	C 183.5	D 28	Nm	in. lb.	78
			inch	6 13/16"	7 15/64"	1 7/64"			
		W44 W45	mm	B 173	C 190.5	D 28	Nm	in. lb.	
inch	6 13/16"		7 1/2"	1 1/32"	1100÷1500	9700÷1325			
W44 W45	mm	B 173	C 198.5	D 28	Nm	in. lb.			
	inch	6 13/16"	7 13/16"	1 1/32"			1100÷1800	9700÷15900	
RB RB2-RB3 	40	RB2 RB3	mm	B 134	C 180	D 26	Nm	in. lb.	83
			inch	5 9/32"	7 3/32"	1 1/32"			
	RB2 RB3	mm	B 134	C 180	D 26	Nm	in. lb.		
		inch	5 9/32"	7 3/32"	1 1/32"			2100	
RB2 RB3	mm	B 162	C 187	D 26	Nm	in. lb.			
	inch	6 3/8"	7 23/64"	1 1/32"			2500	22100	
RB2 RB3	mm	B 162	C 197	D 26	Nm	in. lb.			
	inch	6 3/8"	7 3/4"	1 1/32"			3500	30900	
RB RB4-RB5 	60	RB4 RB5	mm	B 162	C 187	D 28	Nm	in. lb.	83
			inch	6 3/8"	7 23/64"	1 7/64"			
RB4 RB5	mm	B 162	C 197	D 28	Nm	in. lb.			
	inch	6 3/8"	7 3/4"	1 7/64"			3500	30900	



Type	Ref.					 MAX		P.	
			B	C	D	Nm	in. lb.		
RF RF2-RF3-RF6-RF7	40	RF2	mm	195	175	26	900	7950	85
		RF3	inch	7 43/64"	6 57/64"	1 3/32"			
	50	RF2	mm	195	175	26	900	7950	
		RF3	inch	7 43/64"	6 57/64"	1 3/32"			
		RF6	mm	195	190	26	1200	10600	
		RF7	inch	7 43/64"	7 31/64"	1 3/32"			
	60	RF6	mm	195	190	26	1400	12400	
		RF7	inch	7 43/64"	7 31/64"	1 3/32"			
	80	RF6	mm	195	203	26	1400	12400	
		RF7	inch	7 43/64"	7 63/64"	1 3/32"			
90	RF6	mm	195	203	26	1400	12400		
	RF7	inch	7 43/64"	7 63/64"	1 3/32"				

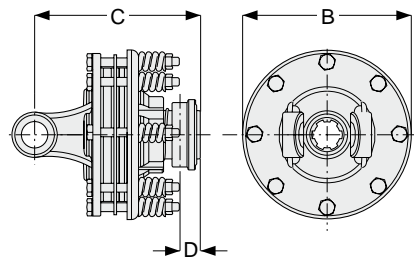

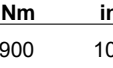
Type	Ref.					 MAX		P.	
			B	C	D	Nm	in. lb.		
RF RF4-RF5-RF8-RF9	40	RF4	mm	195	175	28	900	10600	85
		RF5	inch	7 43/64"	6 57/64"	1 7/64"			
	50	RF4	mm	195	190	28	900	7950	
		RF5	inch	7 43/64"	7 31/64"	1 7/64"			
		RF8	mm	195	175	28	1200	10600	
		RF9	inch	7 43/64"	6 57/64"	1 7/64"			
	60	RF8	mm	195	190	28	1400	12400	
		RF9	inch	7 43/64"	7 31/64"	1 7/64"			
	80	RF8	mm	195	203	28	1400	12400	
		RF9	inch	7 43/64"	7 63/64"	1 7/64"			
90	RF8	mm	195	203	28	1400	12400		
	RF9	inch	7 43/64"	7 63/64"	1 7/64"				

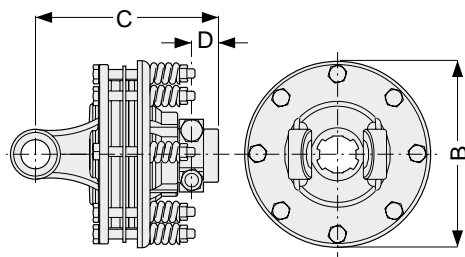

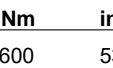
Type	Ref.					 MAX		P.	
			B	C	D	Nm	in. lb.		
RW	20	RW2	mm	ø173	149	26	600	5300	91
		RW3	inch	6 13/16"	5 7/8"	1 1/32"			
	40	RW2	mm	ø173	161	26	600	5300	
		RW3	inch	6 13/16"	6 3/8"	1 1/32"			
		RW2	mm	ø173	161	26	750	6630	
		RW3	inch	6 13/16"	6 3/8"	1 1/32"			
		RW2	mm	ø173	161	26	900	7950	
		RW3	inch	6 13/16"	6 3/8"	1 1/32"			
	50	RW2	mm	ø173	179.5	26	900	7950	
		RW3	inch	6 13/16"	7 3/32"	1 1/32"			
		RW6	mm	ø173	179.5	26	1200	10600	
		RW7	inch	6 13/16"	7 3/32"	1 1/32"			
	60	RW2	mm	ø173	186.5	26	900	7950	
		RW3	inch	6 13/16"	7 23/64"	1 1/32"			
		RW6	mm	ø173	186.5	26	1200	10600	
		RW7	inch	6 13/16"	7 23/64"	1 1/32"			
RW6		mm	ø173	186.5	26	1500	13250		
RW7		inch	6 13/16"	7 23/64"	1 1/32"				
80	RW2	mm	ø173	189.5	26	1200	10600		
	RW3	inch	6 13/16"	7 31/64"	1 1/32"				
	RW6	mm	ø173	189.5	26	1500	13250		
	RW7	inch	6 13/16"	7 31/64"	1 1/32"				
	RW6	mm	ø173	189.5	26	1800	15900		
	RW7	inch	6 13/16"	7 31/64"	1 1/32"				

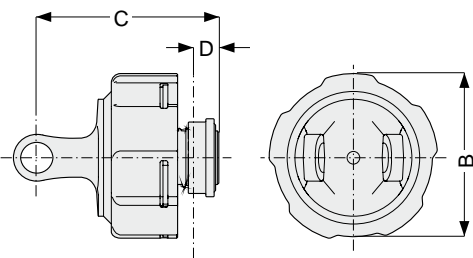

Tutti i dispositivi di sicurezza devono essere montati lato macchina operatrice.

All safety devices must be installed on the implement side of the PTO driveshaft.

LIMITATORE A BULLONE DI TRANCIO SHEAR BOLT TORQUE LIMITER

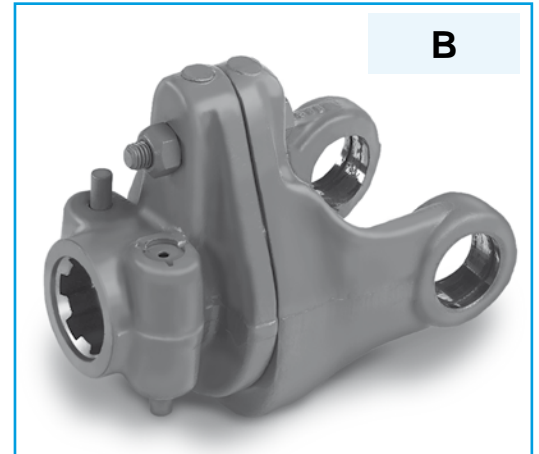
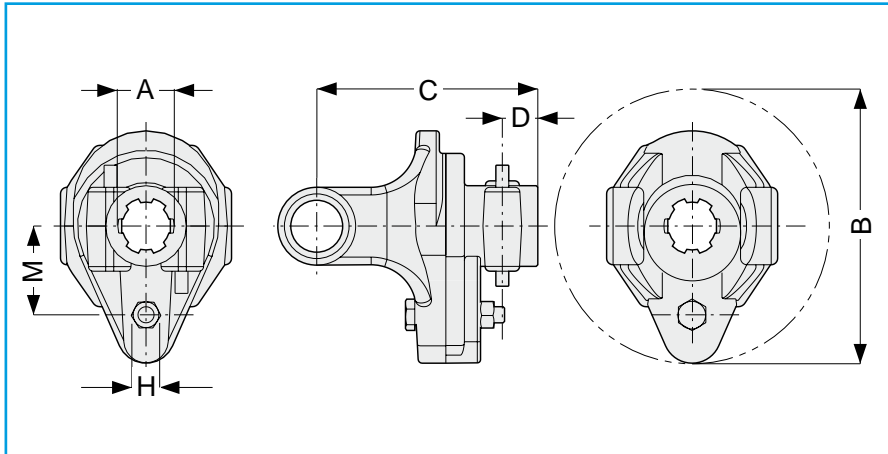

Type	Ref.	A		B		C		D		M		MAX		H ISO 8.8	Code
		[mm]	[inch]	[mm]	[inch]	[mm]	[inch]	[mm]	[inch]	[mm]	[inch]	[Nm]	[in.lb]		
10	B02	1 3/8"	z.6	120	4 23/32"	95	3 47/64"	19	3/4"	36	1 27/64"	650	5700	M6x45	143.210.001.1
	B03	1 3/8"	z.21	120	4 23/32"	95	3 47/64"	19	3/4"	36	1 27/64"	650	5700	M6x45	143.210.002.1
20	B02	1 3/8"	z.6	120	4 23/32"	97	3 13/16"	19	3/4"	48	1 57/64"	900	7950	M6x40	143.220.001.1
	B03	1 3/8"	z.21	120	4 23/32"	97	3 13/16"	19	3/4"	48	1 57/64"	900	7950	M6x40	143.220.002.1
40	B02	1 3/8"	z.6	134	5 9/32"	118	4 41/64"	19	3/4"	55	2 11/64"	1700	15000	M8x50	143.240.001.1
	B03	1 3/8"	z.21	134	5 9/32"	118	4 41/64"	19	3/4"	55	2 11/64"	1700	15000	M8x50	143.240.002.1
50	B02	1 3/8"	z.6	134	5 9/32"	118	4 41/64"	19	3/4"	46	1 13/16"	2100	18500	M10x55	143.250.001.1
	B03	1 3/8"	z.6	134	5 9/32"	118	4 41/64"	19	3/4"	46	1 13/16"	2100	18500	M10x55	143.250.002.1
60	B02	1 3/8"	z.6	162	6 3/8"	137	5 25/64"	22	7/8"	55	2 11/64"	2500	22100	M10x60	143.260.001.1
	B03	1 3/8"	z.21	162	6 3/8"	137	5 25/64"	22	7/8"	55	2 11/64"	2500	22100	M10x60	143.260.003.1
	B04	1 3/4"	z.6	162	6 3/8"	137	5 25/64"	22	7/8"	55	2 11/64"	2500	22100	M10x60	143.260.002.1
	B05	1 3/4"	z.20	162	6 3/8"	137	5 25/64"	22	7/8"	55	2 11/64"	2500	22100	M10x60	143.260.004.1
80	B02	1 3/8"	z.6	162	6 3/8"	146	5 3/4"	22	7/8"	57	2 1/4"	3500	30900	M12x65	143.280.001.1
	B03	1 3/8"	z.21	162	6 3/8"	146	5 3/4"	22	7/8"	57	2 1/4"	3500	30900	M12x65	143.280.003.1
	B04	1 3/4"	z.6	162	6 3/8"	146	5 3/4"	22	7/8"	57	2 1/4"	3500	30900	M12x65	143.280.002.1
	B05	1 3/4"	z.20	162	6 3/8"	146	5 3/4"	22	7/8"	57	2 1/4"	3500	30900	M12x65	143.280.004.1
90	B02	1 3/8"	z.6	162	6 3/8"	152	6"	22	7/8"	65	2 9/16"	4000	35400	M12x65	143.290.001.1
	B03	1 3/8"	z.21	162	6 3/8"	152	6"	22	7/8"	65	2 9/16"	4000	35400	M12x65	143.290.002.1
	B04	1 3/4"	z.6	162	6 3/8"	152	6"	22	7/8"	65	2 9/16"	4000	35400	M12x65	143.290.003.1
	B05	1 3/4"	z.20	162	6 3/8"	152	6"	22	7/8"	65	2 9/16"	4000	35400	M12x65	143.290.004.1

NOTA: fornibile a richiesta con bullone interferente

NOTE: available on demand with interfering clamp bolt

Il limitatore interviene interrompendo la trasmissione di potenza quando la coppia supera il limite di taratura mediante la rottura del bullone. La trasmissione viene ripristinata inserendo un nuovo bullone nel dispositivo.

The torque limiter interrupts the power transmission when the torque exceeds the setting value, by shearing the bolt. Transmission is restored by inserting a new bolt in the device.

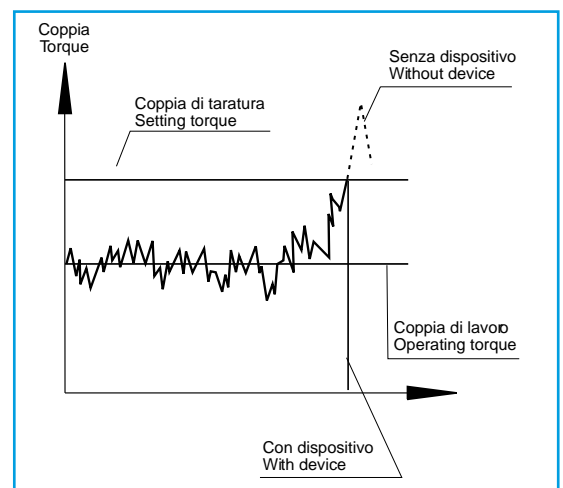

LIMITATORE A BULLONE DI TRANCIO

SHEAR BOLT TORQUE LIMITER



B

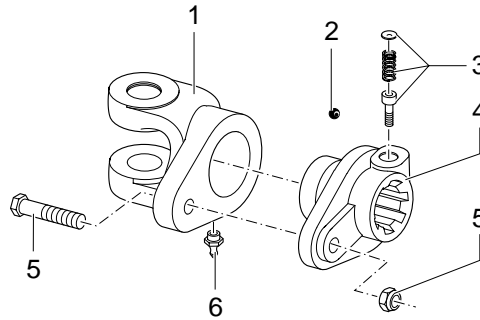

Pos.	Description		Code	Qty *
1	Forcella B (tipo 10)	Yoke B (type 10)	151.011.205.1	1
	Forcella B (tipo 20)	Yoke B (type 20)	151.012.005.1	1
	Forcella B (tipo 40)	Yoke B (type 40)	151.014.012.1	1
	Forcella B (tipo 50)	Yoke B (type 50)	151.015.024.1	1
	Forcella B (tipo 60)	Yoke B (type 60)	151.016.042.1	1
	Forcella B (tipo 80)	Yoke B (type 80)	151.018.023.1	1
	Forcella B (tipo 90)	Yoke B (type 90)	151.019.136.1	1
2	Sfera 7/32" (tipo 10-20)	Ball 7/32" (type 10-20)	190.000.024	24
	Sfera 1/4" (tipo 40-50)	Ball 1/4" (type 40-50)	190.000.022	23
	Sfera 5/16" (tipo 60-80-90)	Ball 5/16" (type 60-80-90)	190.000.023	24
→ 3	Kit pulsante 1 3/8"	Push-pin set 1 3/8"	166.026.004	1 ÷ 2
	Kit pulsante 1 3/4"	Push-pin set 1 3/4"	166.026.005	1 ÷ 2
4	Mozzo B02 (tipo 10)	Hub B02 (type 10)	141.021.201.1	1
	Mozzo B03 (tipo 10)	Hub B03 (type 10)	141.021.332.1	1
	Mozzo B02 (tipo 20)	Hub B02 (type 20)	141.022.010.1	1
	Mozzo B03 (tipo 20)	Hub B03 (type 20)	141.022.017.1	1
	Mozzo B02 (tipo 40)	Hub B02 (type 40)	141.024.013.1	1
	Mozzo B03 (tipo 40)	Hub B03 (type 40)	141.024.026.1	1
	Mozzo B02 (tipo 50)	Hub B02 (type 50)	141.025.025.1	1
	Mozzo B03 (tipo 50)	Hub B03 (type 50)	141.025.013.1	1
	Mozzo B02 (tipo 60)	Hub B02 (type 60)	141.026.043.1	1
	Mozzo B03 (tipo 60)	Hub B03 (type 60)	141.026.026.1	1
	Mozzo B04 (tipo 60)	Hub B04 (type 60)	141.026.044.1	1
	Mozzo B05 (tipo 60)	Hub B05 (type 60)	141.026.027.1	1
	Mozzo B02 (tipo 80)	Hub B02 (type 80)	141.028.024.1	1
	Mozzo B03 (tipo 80)	Hub B03 (type 80)	141.028.037.1	1
	Mozzo B04 (tipo 80)	Hub B04 (type 80)	141.028.025.1	1
	Mozzo B05 (tipo 80)	Hub B05 (type 80)	141.028.038.1	1
	Mozzo B02 (tipo 90)	Hub B02 (type 90)	141.029.137.1	1
Mozzo B03 (tipo 90)	Hub B03 (type 90)	141.029.142.1	1	
Mozzo B04 (tipo 90)	Hub B04 (type 90)	141.029.141.1	1	
Mozzo B05 (tipo 90)	Hub B05 (type 90)	141.029.140.1	1	
5	Vite M6x45 + dado	Bolt M6x45+nut	165.000.597	1
	Vite M6x40 + dado	Bolt M6x40+nut	165.000.509	1
	Vite M8x50 + dado	Bolt M8x50+nut	165.000.505	1
	Vite M10x55 + dado	Bolt M10x55+nut	165.000.511	1
	Vite M10x60 + dado	Bolt M10x60+nut	165.000.507	1
	Vite M12x65 + dado	Bolt M12x65+nut	165.000.512	1
6	Ingrassatore M8x1 (tipo 10-50)	Greaser M8x1 (type 10-50)	190.000.020	1
	Ingrassatore M10x1 (tipo 60-90)	Greaser M10x1 (type 60-90)	190.000.021	1

Dispositivi di sicurezza integrali
Integral Safety Devices



Contattare ufficio tecnico per l'esatta indicazione del n. kit pulsante da ordinare.
Please contact Comer Technical Dept. for the exact number of push-pin set to be ordered.

* Quantità presente nel dispositivo
Quantity in the Safety Device

LIMITATORE A NOTTOLINI BIDIREZIONALE BI-DIRECTIONAL RATCHET CLUTCH TORQUE LIMITER

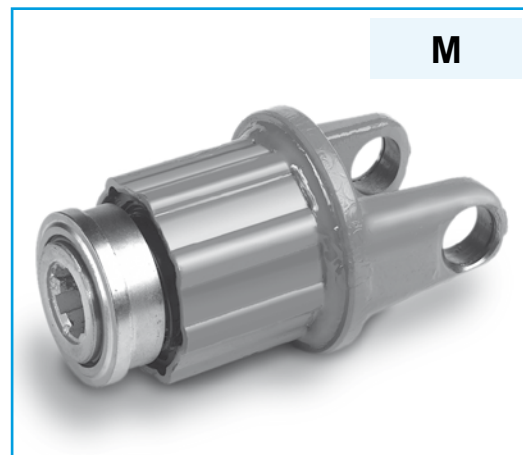
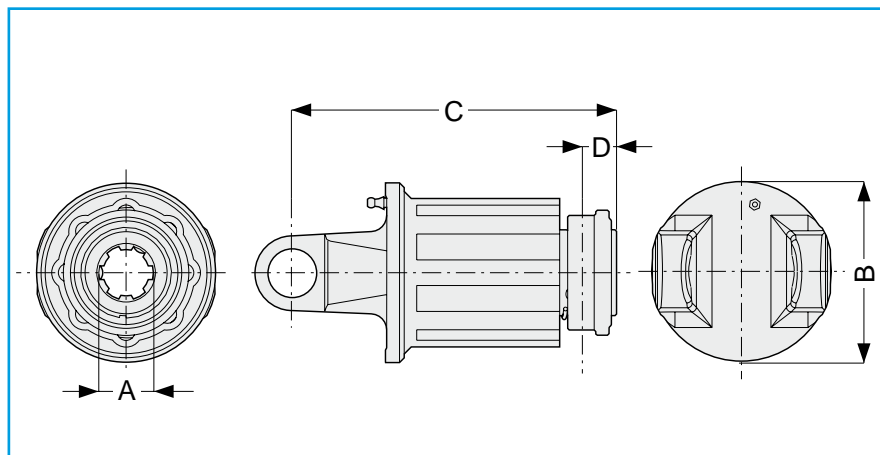

Type	Ref.	A	B		C		D		MAX		Code
			[mm]	[inch]	[mm]	[inch]	[mm]	[inch]	[Nm]	[in.lb]	
10	M14	1 3/8" z.6	100	3 15/16"	121	4 49/64"	26	1 1/32"	300	2650	144.216.062.1
	M15	1 3/8" z.21	100	3 15/16"	121	4 49/64"	26	1 1/32"	300	2650	144.216.069.1
	M24	1 3/8" z.6	100	3 15/16"	141	5 35/64"	26	1 1/32"	600	5300	144.216.070.1
	M25	1 3/8" z.21	100	3 15/16"	141	5 35/64"	26	1 1/32"	600	5300	144.216.071.1
20	M14	1 3/8" z.6	100	3 15/16"	126	4 61/64"	26	1 1/32"	300	2650	144.226.041.1
	M15	1 3/8" z.21	100	3 15/16"	126	4 61/64"	26	1 1/32"	300	2650	144.226.053.1
	M24	1 3/8" z.6	100	3 15/16"	146	5 3/4"	26	1 1/32"	600	5300	144.226.042.1
	M25	1 3/8" z.21	100	3 15/16"	146	5 3/4"	26	1 1/32"	600	5300	144.226.054.1
	M34	1 3/8" z.6	100	3 15/16"	166	6 17/32"	26	1 1/32"	900	7950	144.226.044.1
	M35	1 3/8" z.21	100	3 15/16"	166	6 17/32"	26	1 1/32"	900	7950	144.226.055.1
40	M24	1 3/8" z.6	100	3 15/16"	157	6 3/16"	26	1 1/32"	600	5300	144.246.051.1
	M25	1 3/8" z.21	100	3 15/16"	157	6 3/16"	26	1 1/32"	600	5300	144.246.056.1
	M34	1 3/8" z.6	100	3 15/16"	177	6 31/32"	26	1 1/32"	900	7950	144.246.049.1
	M35	1 3/8" z.21	100	3 15/16"	177	6 31/32"	26	1 1/32"	900	7950	144.246.057.1
	M44	1 3/8" z.6	100	3 15/16"	197	7 3/4"	26	1 1/32"	1200	10600	144.246.048.1
	M45	1 3/8" z.21	100	3 15/16"	197	7 3/4"	26	1 1/32"	1200	10600	144.246.058.1
50	M24	1 3/8" z.6	100	3 15/16"	159	6 17/64"	26	1 1/32"	600	5300	144.256.028.1
	M25	1 3/8" z.21	100	3 15/16"	159	6 17/64"	26	1 1/32"	600	5300	144.256.029.1
	M34	1 3/8" z.6	100	3 15/16"	179	7 3/64"	26	1 1/32"	900	7950	144.256.030.1
	M35	1 3/8" z.21	100	3 15/16"	179	7 3/64"	26	1 1/32"	900	7950	144.256.031.1
	M44	1 3/8" z.6	100	3 15/16"	199	7 53/64"	26	1 1/32"	1200	10600	144.256.032.1
	M45	1 3/8" z.21	100	3 15/16"	199	7 53/64"	26	1 1/32"	1200	10600	144.256.033.1
60	M34	1 3/8" z.6	115	4 17/32"	187	7 23/64"	26	1 1/32"	900	7950	144.266.030.1
	M35	1 3/8" z.21	115	4 17/32"	187	7 23/64"	26	1 1/32"	900	7950	144.266.033.1
	M44	1 3/8" z.6	115	4 17/32"	207	8 5/32"	26	1 1/32"	1200	10600	144.266.029.1
	M45	1 3/8" z.21	115	4 17/32"	207	8 5/32"	26	1 1/32"	1200	10600	144.266.034.1

Il dispositivo limitatore interviene quando la coppia di funzionamento supera il valore di taratura. Durante la fase di limitazione il dispositivo trasmette una potenza ridotta e in modo impulsivo. L'eliminazione della causa esterna e la diminuzione della velocità della PTO fa riprendere la normale trasmissione di potenza. All'atto dell'intervento del limitatore è bene staccare la presa di forza per evitare inutili usure e riscaldamento.

The torque limiter is activated when the operating torque exceeds the setting value. During the limiting phase, the device transmits reduced power in pulses. The elimination of the external cause and the reduction of the PTO speed allows the normal power transmission to be re-established. When the limiter is activated, it is recommended to disconnect the PTO to avoid unnecessary wear and overheating.

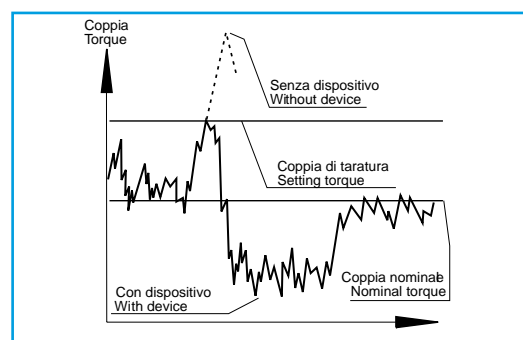

LIMITATORE A NOTTOLINI BIDIREZIONALE BI-DIRECTIONAL RATCHET CLUTCH TORQUE LIMITER



M

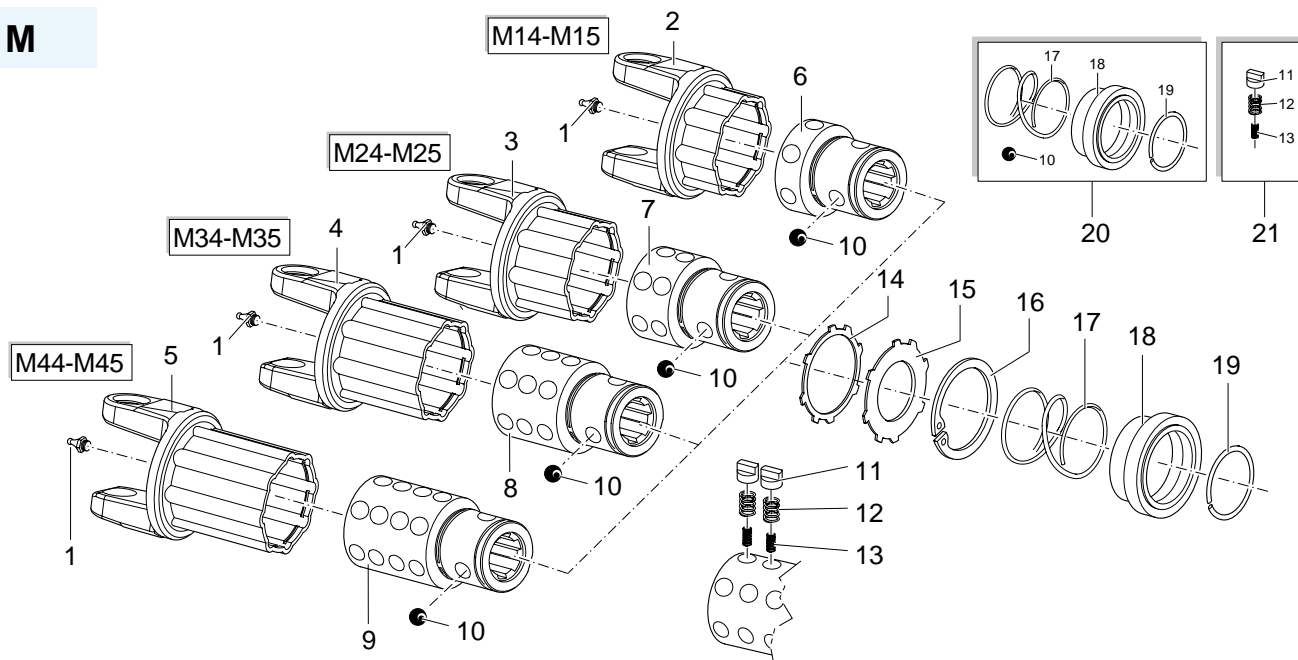

Pos.	Description		Code	Qty *
1	Ingrassatore M6x1	Greaser M6x1	190.000.047	1
2	Forcella corpo M14-M15 (tipo 10)	Yoke support M14-M15 (type 10)	141.021.205.1	1
	Forcella corpo M14-M15 (tipo 20)	Yoke support M14-M15 (type 20)	141.022.205.1	1
3	Forcella corpo M24-M25 (tipo 10)	Yoke support M24-M25 (type 10)	141.021.206.1	1
	Forcella corpo M24-M25 (tipo 20)	Yoke support M24-M25 (type 20)	141.022.206.1	1
	Forcella corpo M24-M25 (tipo 40)	Yoke support M24-M25 (type 40)	141.024.206.1	1
	Forcella corpo M24-M25 (tipo 50)	Yoke support M24-M25 (type 50)	141.025.206.1	1
4	Forcella corpo M34-M35 (tipo 20)	Yoke support M34-M35 (type 20)	141.022.207.1	1
	Forcella corpo M34-M35 (tipo 40)	Yoke support M34-M35 (type 40)	141.024.207.1	1
	Forcella corpo M34-M35 (tipo 50)	Yoke support M34-M35 (type 50)	141.025.207.1	1
	Forcella corpo M34-M35 (tipo 60)	Yoke support M34-M35 (type 60)	141.026.207.1	1
5	Forcella corpo M44-M45 (tipo 40)	Yoke support M44-M45 (type 40)	141.024.208.1	1
	Forcella corpo M44-M45 (tipo 50)	Yoke support M44-M45 (type 50)	141.025.208.1	1
	Forcella corpo M44-M45 (tipo 60)	Yoke support M44-M45 (type 60)	141.026.208.1	1
6	Mozzo M14	Hub M14	151.013.319	1
	Mozzo M15	Hub M15	151.013.320	1
7	Mozzo M24	Hub M24	151.013.316	1
	Mozzo M25	Hub M25	151.013.321	1
8	Mozzo M34	Hub M34	151.013.322	1
	Mozzo M35	Hub M35	151.013.323	1
9	Mozzo M44	Hub M44	151.013.324	1
	Mozzo M45	Hub M45	151.013.325	1
10	Sfera 1/2"	Ball 1/2"	190.000.078	3
→ 11	Nottolino	Ratchet tooth	180.015.168	1 + 32
→ 12	Molla esterna	Outer spring	180.013.032	1 + 32
→ 13	Molla interna	Inner spring	180.013.033	1 + 32
14	Distanziale	Retaining washer	180.015.137	1
15	Paragrasso	Grease protection	180.013.334	1
16	Seeger	Circlip	190.000.178	1
17	Molla collar	Collar spring	180.016.487	1
18	Manicotto collar	Sliding sleeve collar	151.016.486	1
19	Seeger	Snap ring	190.000.451	1
20	Kit collar M	Kit Collar M	165.000.719	1
21	Kit nottolini e molle	Ratchet teeth and springs set	166.026.010	1 + 4

Il kit comprende n. 8 nottolini, n. 8 molle interne, n. 8 molle esterne.
The set includes Nr.8 ratchet teeth, Nr.8 outer spring and Nr.8 inner spring.

Dispositivi di sicurezza integrali
Integral Safety Devices



Contattare ufficio tecnico per l'esatta indicazione del n. di nottolini, molle esterne ed interne da ordinare.
Please contact Comer Technical Dept. for the exact number of ratchet teeth, outer and inner springs to be ordered.

* Quantità presente nel dispositivo
Quantity in the Safety Device

RUOTA LIBERA OVERRUNNING CLUTCH

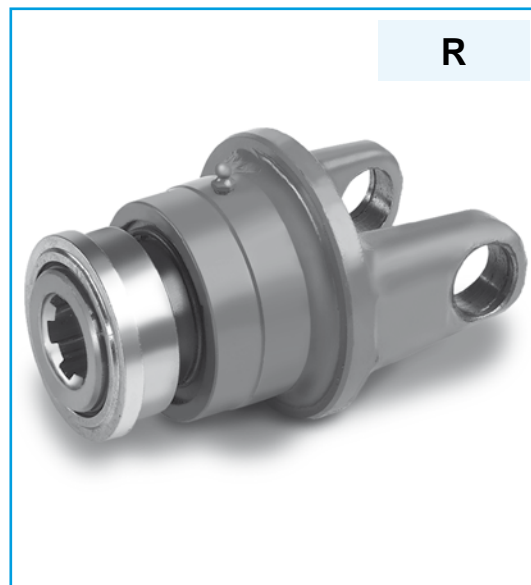
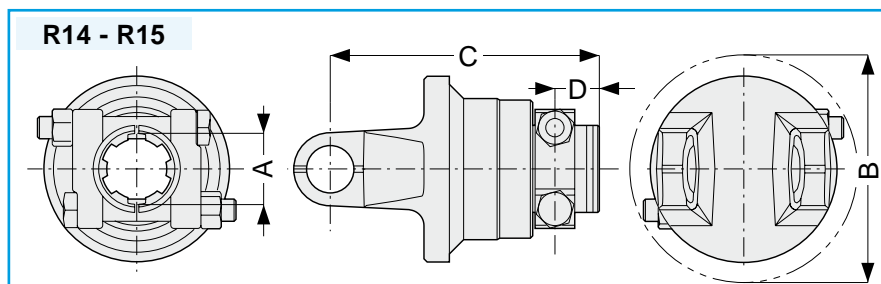
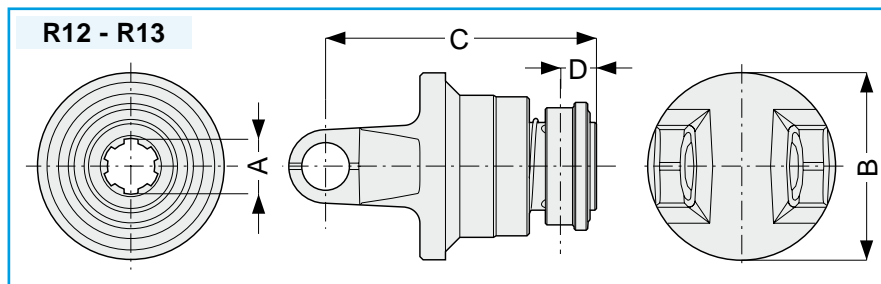

Type	Ref.	A		B		C		D		MAX		Code
		[mm]	[inch]	[mm]	[inch]	[mm]	[inch]	[mm]	[inch]	[Nm]	[in.lb]	
10	R12	1 3/8"	z.6	96	3 25/32"	141	5 35/64"	26	1 1/32"	3800	33630	145.215.011.1
	R13	1 3/8"	z.21	96	3 25/32"	141	5 35/64"	26	1 1/32"	3800	33630	145.215.012.1
20	R12	1 3/8"	z.6	96	3 25/32"	146	5 3/4"	26	1 1/32"	3800	33630	145.225.011.1
	R13	1 3/8"	z.21	96	3 25/32"	146	5 3/4"	26	1 1/32"	3800	33630	145.225.012.1
40	R12	1 3/8"	z.6	96	3 25/32"	157	6 3/16"	26	1 1/32"	3800	33630	145.245.011.1
	R13	1 3/8"	z.21	96	3 25/32"	157	6 3/16"	26	1 1/32"	3800	33630	145.245.012.1
	R14	1 3/4"	z.6	140	5 33/64"	157	6 3/16"	28	1 7/64"	3800	33630	145.245.019.1
50	R15	1 3/4"	z.20	140	5 33/64"	157	6 3/16"	28	1 7/64"	3800	33630	145.245.020.1
	R12	1 3/8"	z.6	100	3 15/16"	159	6 17/64"	26	1 1/32"	3800	33630	145.255.011.1
	R13	1 3/8"	z.21	100	3 15/16"	159	6 17/64"	26	1 1/32"	3800	33630	145.255.012.1
	R14	1 3/4"	z.6	140	5 33/64"	159	6 17/64"	28	1 7/64"	3800	33630	145.255.014.1
60	R15	1 3/4"	z.20	140	5 33/64"	159	6 17/64"	28	1 7/64"	3800	33630	145.255.015.1
	R12	1 3/8"	z.6	115	4 17/32"	167	6 37/64"	26	1 1/32"	3800	33630	145.265.011.1
	R13	1 3/8"	z.21	115	4 17/32"	167	6 37/64"	26	1 1/32"	3800	33630	145.265.012.1
	R14	1 3/4"	z.6	140	5 33/64"	167	6 37/64"	28	1 7/64"	3800	33630	145.265.017.1
80	R15	1 3/4"	z.20	140	5 33/64"	167	6 37/64"	28	1 7/64"	3800	33630	145.265.019.1
	R12	1 3/8"	z.6	127	5"	176	6 59/64"	26	1 1/32"	3800	33630	145.285.011.1
	R13	1 3/8"	z.21	127	5"	176	6 59/64"	26	1 1/32"	3800	33630	145.285.012.1
	R14	1 3/4"	z.6	140	5 33/64"	176	6 59/64"	28	1 7/64"	3800	33630	145.285.014.1
												145.285.013.1

NOTA: fornibile a richiesta per senso di rotazione antiorario

Il dispositivo consente di trasmettere il moto in un solo senso di rotazione, quando il trattore aziona la macchina operatrice. Nella fase di arresto, con la PTO trattore disinserita e la macchina ancora in movimento, la trasmissione è disaccoppiata. Tale dispositivo è utile per macchine operatrici con elevata inerzia di rotazione perché, durante la fase di arresto, la PTO del trattore non viene trascinata dalla macchina operatrice.

NOTE: available upon request for anti-clockwise direction of rotation

The device is used to transmit the motion in a single rotation direction, when the tractor drives the implement. During the stopping phase, with the tractor PTO disengaged and the implement still moving, the transmission is disconnected. This device is useful for operating machinery with high rotation inertia because during the stopping phase, the tractor PTO is disengaged from the driven machine.

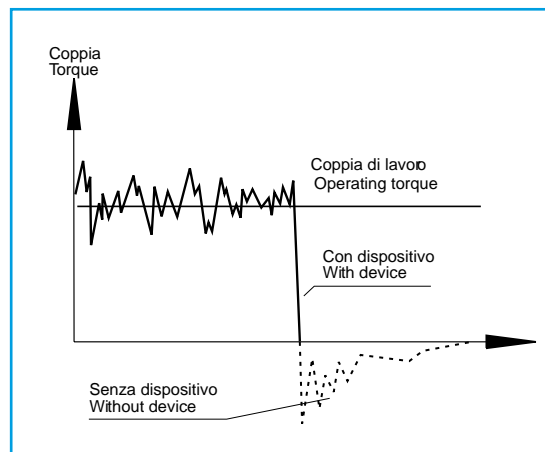

RUOTA LIBERA OVERRUNNING CLUTCH

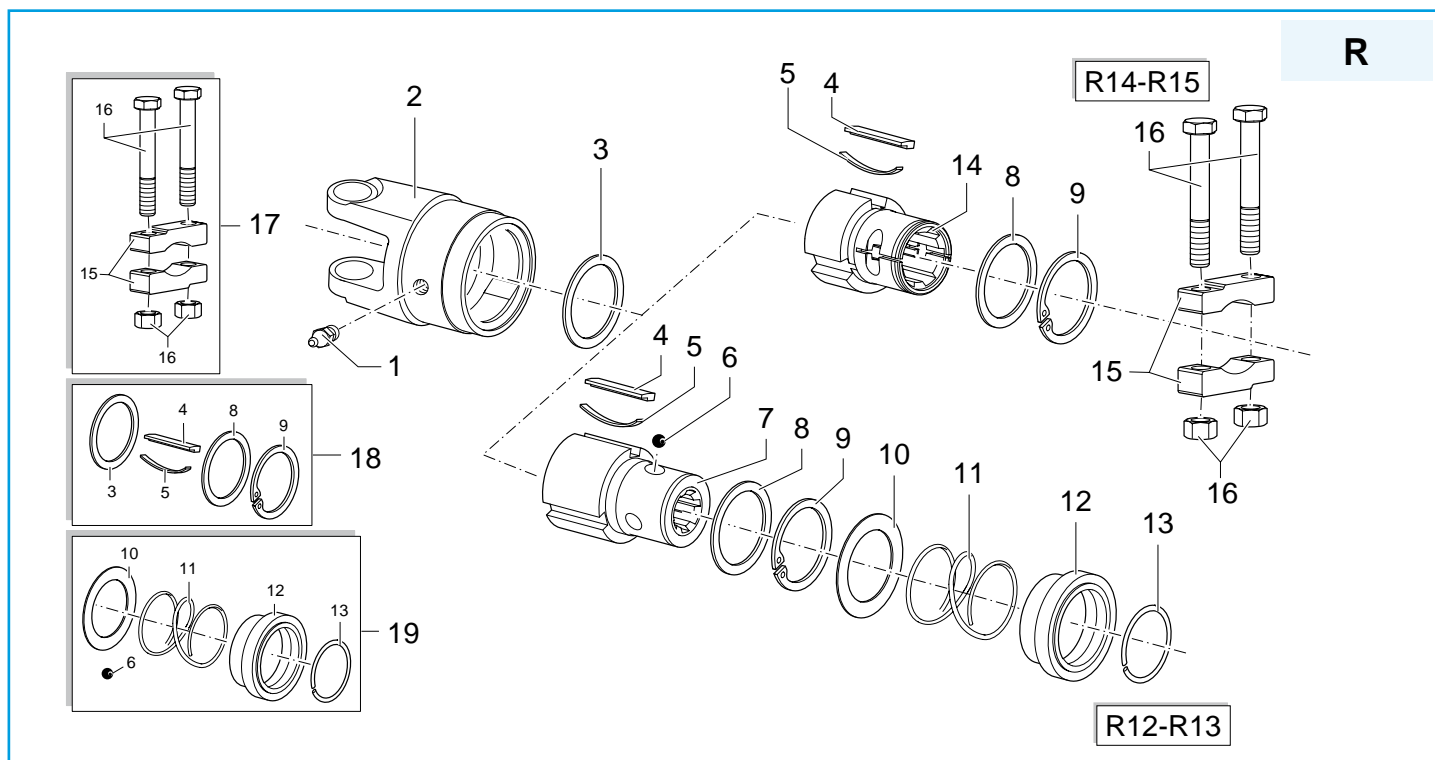

Pos.	Description		Code	Qty *
1	Ingrassatore M8x1	Greaser M8x1	190.000.020	1
2	Forcella corpo R (tipo 10)	Yoke support R (type 10)	141.021.210.1	1
	Forcella corpo R (tipo 20)	Yoke support R (type 20)	141.022.210.1	1
	Forcella corpo R (tipo 40)	Yoke support R (type 40)	141.024.210.1	1
	Forcella corpo R (tipo 50)	Yoke support R (type 50)	141.025.210.1	1
	Forcella corpo R (tipo 60)	Yoke support R (type 60)	141.026.210.1	1
	Forcella corpo R (tipo 80)	Yoke support R (type 80)	141.028.210.1	1
3	Distanziale	Retaining washer	190.000.199	1
4	Linguetta	Ratchet	151.014.136	3
5	Molla a balestra	Leaf spring	180.014.137	3
6	Sfera	Ball	190.000.078	3
7	Mozzo R12	Hub R12	151.016.546	1
	Mozzo R13	Hub R13	151.016.571	1
8	Anello di rasamenfo	Retaining washer ring	180.014.135	1
9	Seeger	Circlip	190.000.183	1
10	Lamierino	Spring push ring	180.015.143	1
11	Molla collar	Collar spring	180.016.487	1
12	Manicotto collar	Sliding sleeve Collar	151.016.486	1
13	Seeger	Snap ring	190.000.451	1
14	Mozzo R14	Hub R14	151.014.200	1
	Mozzo R15	Hub R15	151.018.121	1
15	Ponte di blocco	Clamp lock	151.014.201	2
16	Vite M14x1,5x100 + dado	Bolt M14x1,5x100+nut	165.000.622	2
17	Kit ponti blocco 1 3/4"	Clamp lock set 1 3/4"	165.000.692	1
18	Kit R	Kit R	166.000.547	1
19	Kit collar R12-R13	Kit Collar R12-R13	165.000.653	1

Dispositivi di sicurezza integrali
Integral Safety Devices

* Quantità presente nel dispositivo
Quantity in the Safety Device

FRIZIONE A DISCHI MULTIPLI DISC CLUTCH TORQUE LIMITER

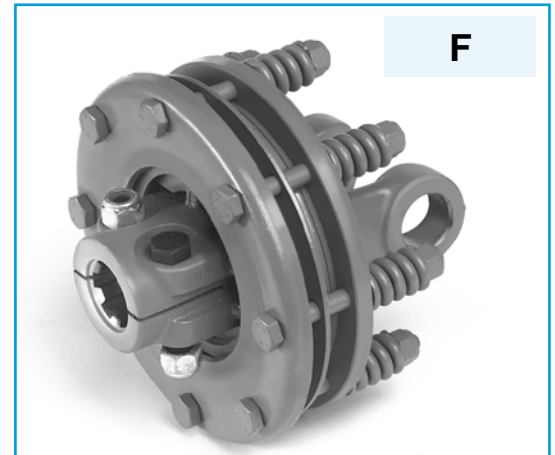
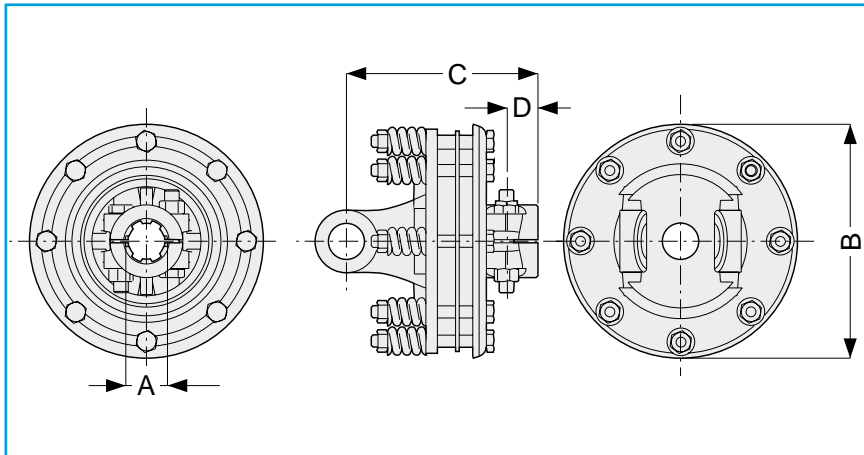

Type	Ref.	A	B		C		D		MAX		Code
			[mm]	[inch]	[mm]	[inch]	[mm]	[inch]	[Nm]	[in.lb]	
20	F02	1 3/8" z.6	153	6 1/32"	120	4 23/32"	22	7/8"	650	5750	146.221.001.1
	F03	1 3/8" z.21	153	6 1/32"	120	4 23/32"	22	7/8"	650	5750	146.221.002.1
	F04	1 3/8" z.6	153	6 1/32"	144	5 21/32"	26	1 1/32"	900	7950	146.221.011.1
	F05	1 3/8" z.21	153	6 1/32"	144	5 21/32"	26	1 1/32"	900	7950	146.221.012.1
40	F02	1 3/8" z.6	153	6 1/32"	133	5 15/64"	22	7/8"	650	5750	146.241.002.1
	F03	1 3/8" z.21	153	6 1/32"	133	5 15/64"	22	7/8"	650	5750	146.241.004.1
	F04	1 3/8" z.6	153	6 1/32"	157	6 3/16"	26	1 1/32"	900	7950	146.241.047.1
	F05	1 3/8" z.21	153	6 1/32"	157	6 3/16"	26	1 1/32"	900	7950	146.241.048.1
	F12	1 3/8" z.6	180	7 3/32"	135	5 5/16"	19	3/4"	900	7950	146.241.001.1
	F13	1 3/8" z.21	180	7 3/32"	135	5 5/16"	19	3/4"	900	7950	146.241.003.1
50	F12	1 3/8" z.6	180	7 3/32"	135	5 5/16"	19	3/4"	900	7950	146.251.001.1
	F13	1 3/8" z.21	180	7 3/32"	135	5 5/16"	19	3/4"	900	7950	146.251.002.1
	F22	1 3/8" z.6	195	7 43/64"	146	5 3/4"	26	1 1/32"	1200	10600	146.252.011.1
	F23	1 3/8" z.21	195	7 43/64"	146	5 3/4"	26	1 1/32"	1200	10600	146.252.012.1
	F24	1 3/4" z.6	195	7 43/64"	146	5 3/4"	26	1 1/32"	1200	10600	146.252.013.1
	F25	1 3/4" z.20	195	7 43/64"	146	5 3/4"	26	1 1/32"	1200	10600	146.252.014.1
60	F12	1 3/8" z.6	180	7 3/32"	135	5 5/16"	19	3/4"	900	7950	146.261.001.1
	F13	1 3/8" z.21	180	7 3/32"	135	5 5/16"	19	3/4"	900	7950	146.261.002.1
	F22	1 3/8" z.6	195	7 43/64"	146	5 3/4"	26	1 1/32"	1200	10600	146.262.011.1
	F23	1 3/8" z.21	195	7 43/64"	146	5 3/4"	26	1 1/32"	1200	10600	146.262.012.1
	F24	1 3/4" z.6	195	7 43/64"	146	5 3/4"	26	1 1/32"	1200	10600	146.262.013.1
	F25	1 3/4" z.20	195	7 43/64"	146	5 3/4"	26	1 1/32"	1200	10600	146.262.014.1
	F42	1 3/8" z.6	195	7 43/64"	156	6 1/8"	26	1 1/32"	1600	14150	146.264.011.1
	F43	1 3/8" z.21	195	7 43/64"	156	6 1/8"	26	1 1/32"	1600	14150	146.264.012.1
	F44	1 3/4" z.6	195	7 43/64"	156	6 1/8"	26	1 1/32"	1600	14150	146.264.013.1
	F45	1 3/4" z.20	195	7 43/64"	156	6 1/8"	26	1 1/32"	1600	14150	146.264.014.1
80	F22	1 3/8" z.6	195	7 43/64"	159	6 17/64"	26	1 1/32"	1200	10600	146.282.011.1
	F23	1 3/8" z.21	195	7 43/64"	159	6 17/64"	26	1 1/32"	1200	10600	146.282.012.1
	F24	1 3/4" z.6	195	7 43/64"	159	6 17/64"	26	1 1/32"	1200	10600	146.282.013.1
	F25	1 3/4" z.20	195	7 43/64"	159	6 17/64"	26	1 1/32"	1200	10600	146.282.014.1
	F42	1 3/8" z.6	195	7 43/64"	169	6 21/32"	26	1 1/32"	2000	17700	146.284.011.1
	F43	1 3/8" z.21	195	7 43/64"	169	6 21/32"	26	1 1/32"	2000	17700	146.284.012.1
	F44	1 3/4" z.6	195	7 43/64"	169	6 21/32"	26	1 1/32"	2000	17700	146.284.013.1
	F45	1 3/4" z.20	195	7 43/64"	169	6 21/32"	26	1 1/32"	2000	17700	146.284.014.1
90	F42	1 3/8" z.6	195	7 43/64"	169	6 21/32"	26	1 1/32"	2000	17700	146.294.011.1
	F43	1 3/8" z.21	195	7 43/64"	169	6 21/32"	26	1 1/32"	2000	17700	146.294.012.1
	F44	1 3/4" z.6	195	7 43/64"	169	6 21/32"	26	1 1/32"	2000	17700	146.294.013.1
	F45	1 3/4" z.20	195	7 43/64"	169	6 21/32"	26	1 1/32"	2000	17700	146.294.014.1

FRIZIONE A DISCHI MULTIPLI DISC CLUTCH TORQUE LIMITER



Il dispositivo limitatore interviene quando la coppia di lavoro supera la coppia di taratura. Durante la fase di limitazione del picco di coppia la frizione continua a trasmettere potenza. La frizione è utile sia come dispositivo di sicurezza contro picchi di carico sia per avviare macchine con elevata inerzia rotazionale. E' utile controllare la corretta taratura per evitare eccessivi riscaldamenti dei dischi d'attrito (taratura insufficiente) o il bloccaggio della frizione (taratura eccessiva).

The torque limiter is activated when the setting torque exceeds the calibration torque. During the torque peak limiting phase, the clutch continues to transmit power. The clutch is useful as a safety device to protect against load peaks and to start machines with high rotational inertia. It is recommended to ensure that the setting value is correct to avoid excessive heating of the friction discs (insufficient setting) or clutch seizing (excessive setting).

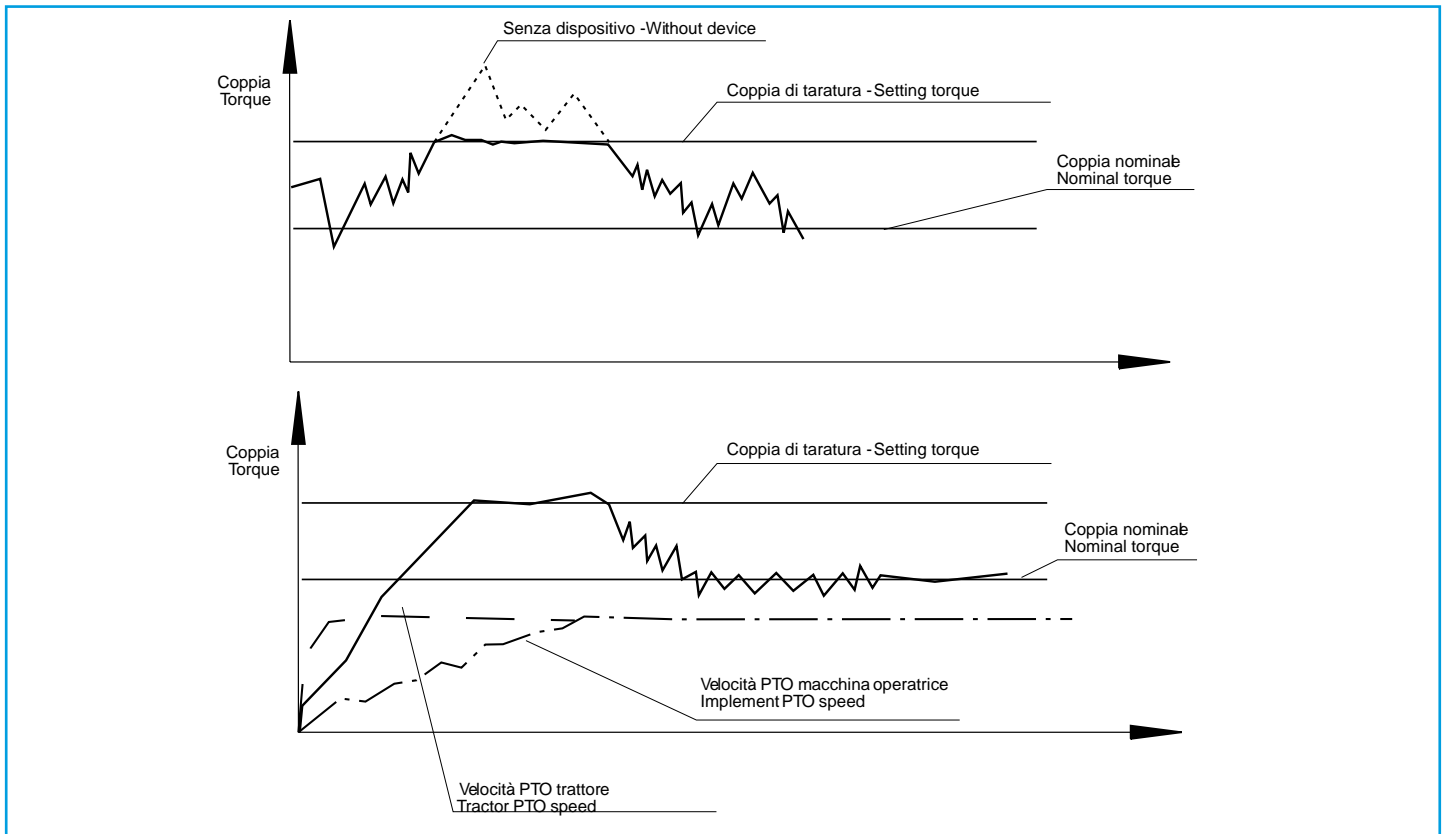

Le frizioni possono raggiungere elevate temperature.

Non toccare!

Per evitare rischi di incendio, mantenere la zona adiacente la frizione pulita da materiale infiammabile ed evitare slittamenti prolungati.

Friction clutches may become hot during use.

Do not touch!

Keep the area around the friction clutch clear of any material which could catch fire and avoid prolonged slipping.



F0

F

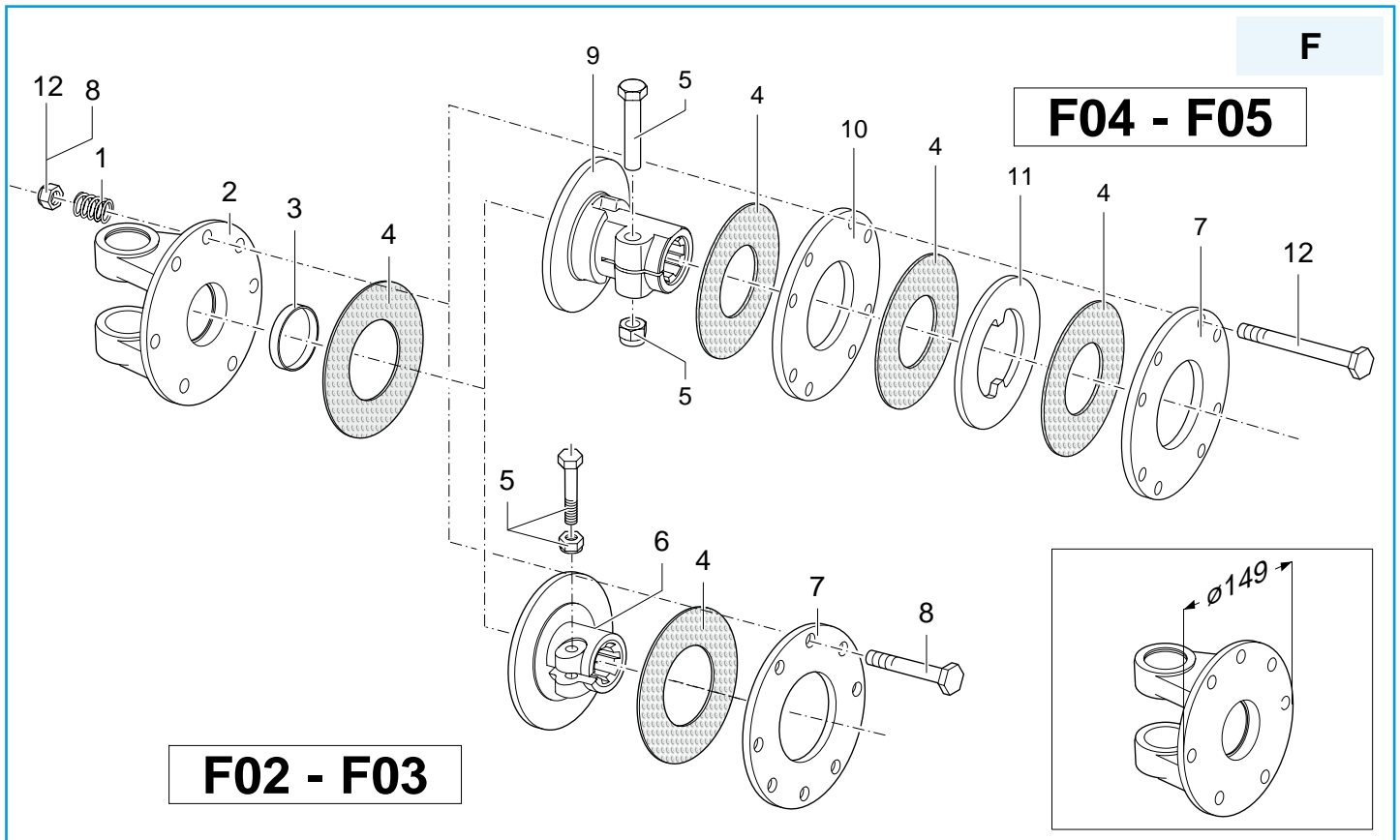

Pos.	Description		Code	Qty *
1	Molla elicoidale ø 6	Spring ø 6	180.014.022	8
2	Forcella flangia (tipo 20)	Flanged yoke (type 20)	151.012.139.1	1
	Forcella flangia (tipo 40)	Flanged yoke (type 40)	151.014.017.1	1
3	Bronzina	Bush	180.015.020	1
4	Dischi attrito ø120xø68 (F02-03)	Lining rings ø120xø68(F02-03)	180.014.019	2
	Dischi attrito ø120xø68 (F04-05)	Lining rings ø120xø68 (F04-05)		4
5	Kit vite M12x1,25x65+dado	Bolt M12x1,25x65+nut	165.000.502	1
6	Mozzo frizione F02	Clutch support F02	151.014.018.1	1
	Mozzo frizione F03	Clutch support F03	151.013.022.1	1
7	Disco stringi frizione (F02-03)	Pressure plate (F02-03)	180.014.020.1	1
8	Kit vite M10x80 + dado (F02-03)	Bolt M10x80+nut (F02-03)	165.000.501	8
9	Mozzo frizione F04	Clutch support F02	151.014.570.1	1
	Mozzo frizione F05	Clutch support F03	151.014.592.1	1
10	Disco intermedio	Inner plate	180.014.571	1
11	Disco sagomato	Intermediate plate	180.014.572	1
12	Kit vite M10x100 + dado (F04-05)	Bolt M10x100+nut (F04-05)	165.000.548	8

* Quantità presente nel dispositivo
Quantity in the Safety Device



F1

F

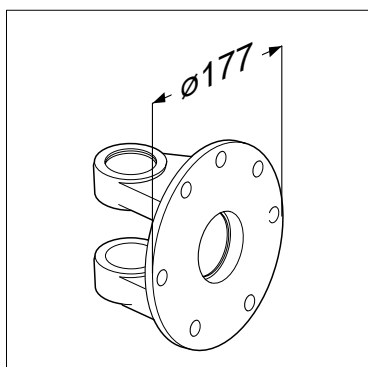
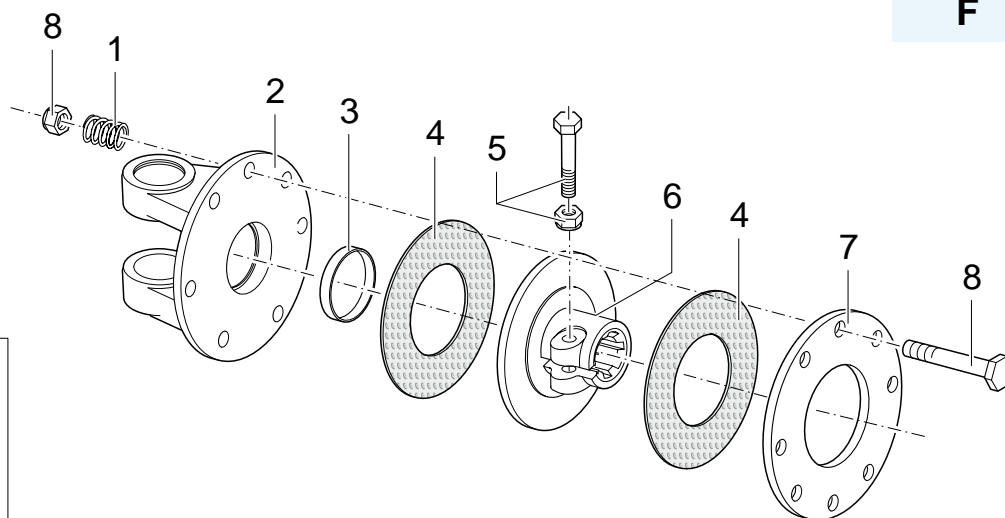

Pos.	Description		Code	Qty *
1	Molla elicoidale $\varnothing 6$	Spring $\varnothing 6$	180.014.022	8
2	Forcella flangia (tipo 40)	Flanged yoke (type 40)	151.014.009.1	1
	Forcella flangia (tipo 50)	Flanged yoke (type 50)	151.015.017.1	1
	Forcella flangia (tipo 60)	Flanged yoke (type 60)	151.016.039.1	1
3	Bronzina	Bush	180.015.020	1
4	Dischi attrito $\varnothing 142 \times \varnothing 77,5$	Lining rings $\varnothing 142 \times \varnothing 77,5$	180.015.019	2
5	Kit vite M12x1,25x65 + dado	Bolt M12x1,25x65+nut	165.000.502	1
6	Mozzo frizione F12	Clutch support F12	151.015.018	1
	Mozzo frizione F13	Clutch support F13	151.015.010	1
9	Disco stringi frizione	Pressure plate	180.015.021	1
10	Kit vite M10x80 + dado	Bolt M10x80+nut	165.000.501	8

* Quantità presente nel dispositivo
Quantity in the Safety Device



F2

F

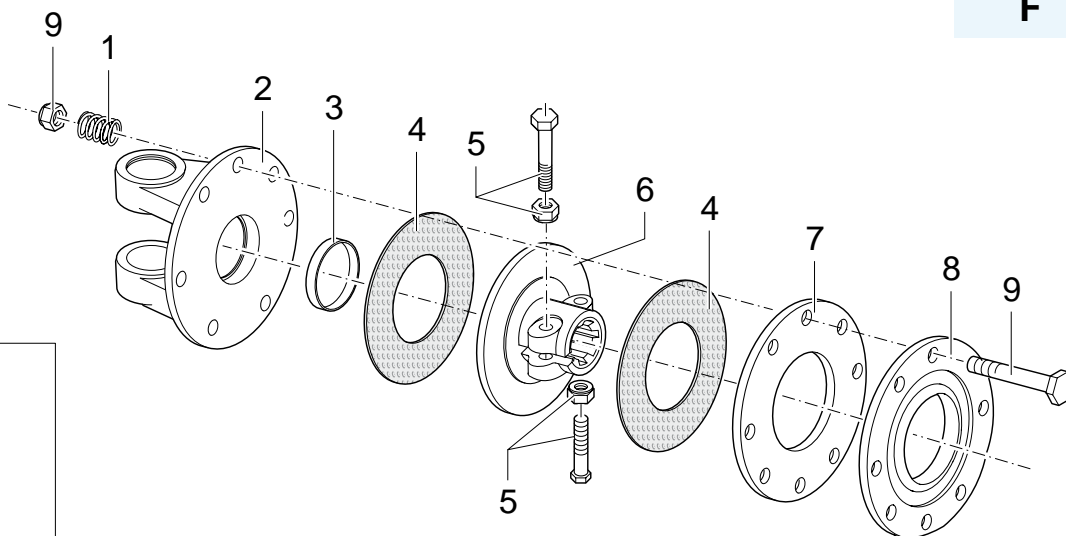

Pos.	Description		Code	Qty *
1	Molla elicoidale \varnothing 7	Spring \varnothing 7	180.019.017	8
2	Forcella flangia (tipo 50)	Flanged yoke (type 50)	151.015.038.1	1
	Forcella flangia (tipo 60)	Flanged yoke (type 60)	151.016.037.1	1
	Forcella flangia (tipo 80)	Flanged yoke (type 80)	151.018.016.1	1
3	Bronzina	Bush	180.019.019	1
4	Dischi attrito \varnothing 152x \varnothing 90	Lining rings \varnothing 152x \varnothing 90	180.019.018	2
5	Kit vite M12x1,25x65 + dado	Bolt M12x1,25x65+nut	165.000.502	2
	Kit vite M14x1,5x70 + dado	Bolt M14x1,5x70+nut	165.000.503	2
6	Mozzo frizione F22	Clutch support F22	151.018.018.1	1
	Mozzo frizione F23	Clutch support F23	151.017.013.1	1
	Mozzo frizione F24	Clutch support F24	151.018.019.1	1
	Mozzo frizione F25	Clutch support F25	151.017.019.1	1
7	Disco intermedio	Inner plate	180.019.014	1
8	Disco stringi frizione	Pressure plate	180.019.116.1	1
9	Kit vite M10x1,5x85 + dado	Bolt M10x1,5x85+nut	165.000.549	8

* Quantità presente nel dispositivo
Quantity in the Safety Device



F4

F

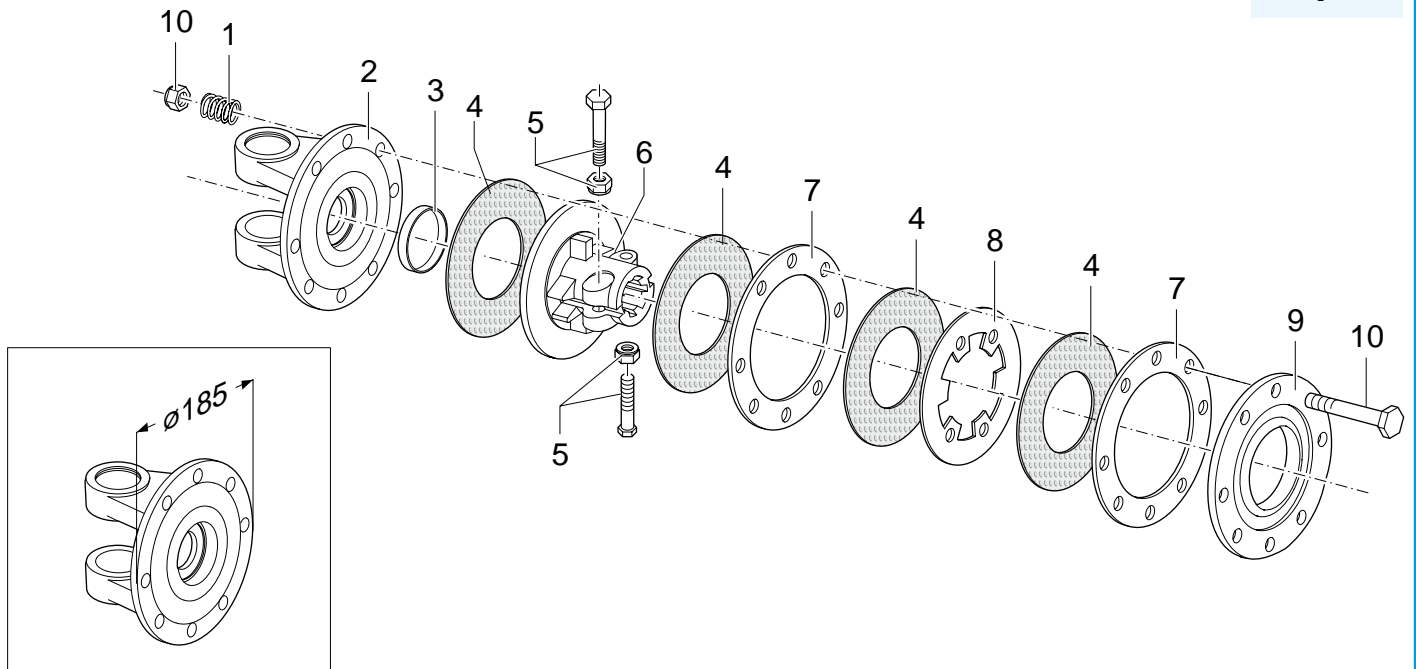

Pos.	Description		Code	Qty *
1	Molla elicoidale \varnothing 6	Spring \varnothing 6	180.014.022	8
2	Forcella flangia (tipo 60)	Flanged yoke (type 60)	151.016.037.1	1
	Forcella flangia (tipo 80)	Flanged yoke (type 80)	151.018.016.1	1
	Forcella flangia (tipo 90)	Flanged yoke (type 90)	151.019.059.1	1
3	Bronzina	Bush	180.019.019	1
4	Dischi attrito \varnothing 152x \varnothing 90	Lining rings \varnothing 152x \varnothing 90	180.019.018	4
5	Kit vite M12x1,25x65 + dado	Bolt M12x1,25x65+nut	165.000.502	2
	Kit vite M14x1,5x70 + dado	Bolt M14x1,5x70+nut	165.000.503	2
6	Mozzo frizione F42	Clutch support F42	151.019.011.1	1
	Mozzo frizione F43	Clutch support F43	151.019.008.1	1
	Mozzo frizione F44	Clutch support F44	151.019.012.1	1
	Mozzo frizione F45	Clutch support F45	151.019.009.1	1
7	Disco intermedio	Inner plate	180.019.014	2
8	Disco sagomato	Intermediate plate	180.019.115	1
9	Disco stringi frizione	Pressure plate	180.019.116.1	1
10	Kit vite M10x1,5x100 + dado	Bolt M10x1,5x100+nut	165.000.548	8

Dispositivi di sicurezza integrali
Integral Safety Devices

* Quantità presente nel dispositivo
Quantity in the Safety Device

FRIZIONE CHIUSA A DICI MULTIPLI CLOSED DISC CLUTCH TORQUE LIMITER

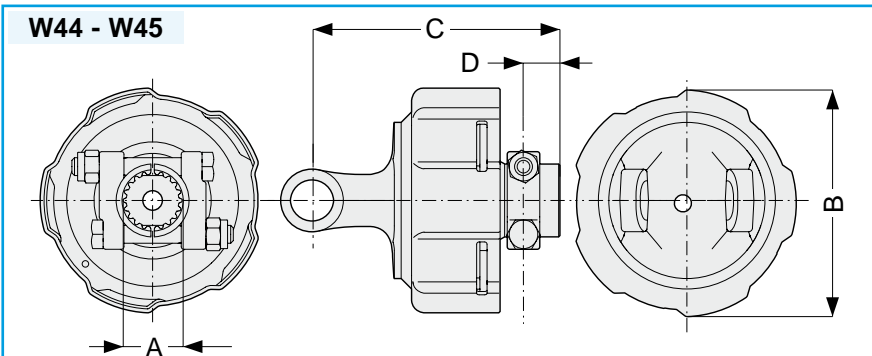
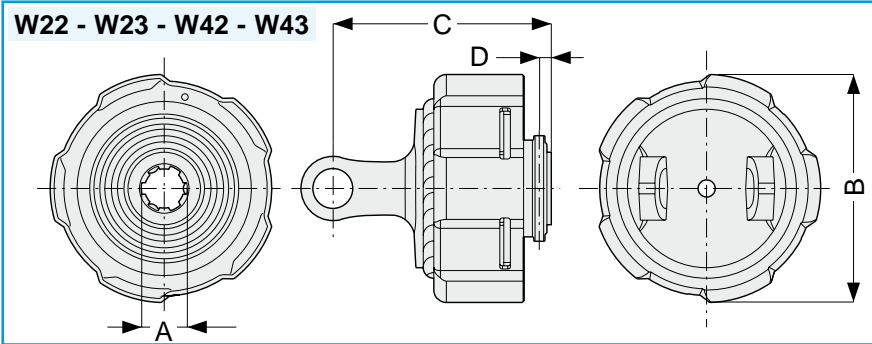

Type	Ref.	A		B		C		D		MAX		Code
		[mm]	[inch]	[mm]	[inch]	[mm]	[inch]	[mm]	[inch]	[Nm]	[in.lb]	
20	W22	1 3/8" z.6	173	6 13/16"	133.5	5 1/4"	26	1 1/32"	600	5300	148.322.001.1	
	W23	1 3/8" z.21	173	6 13/16"	133.5	5 1/4"	26	1 1/32"	600	5300	148.322.002.1	
40	W22	1 3/8" z.6	173	6 13/16"	140.0	5 33/64"	26	1 1/32"	600	5300	148.342.001.1	
	W23	1 3/8" z.21	173	6 13/16"	140.0	5 33/64"	26	1 1/32"	600	5300	148.342.002.1	
	W22	1 3/8" z.6	173	6 13/16"	140.0	5 33/64"	26	1 1/32"	750	6650	148.342.003.1	
	W23	1 3/8" z.21	173	6 13/16"	140.0	5 33/64"	26	1 1/32"	750	6650	148.342.004.1	
	W22	1 3/8" z.6	173	6 13/16"	140.0	5 33/64"	26	1 1/32"	900	7950	148.342.005.1	
	W23	1 3/8" z.21	173	6 13/16"	140.0	5 33/64"	26	1 1/32"	900	7950	148.342.006.1	
50	W22	1 3/8" z.6	173	6 13/16"	143.5	5 21/32"	26	1 1/32"	900	7950	148.352.001.1	
	W23	1 3/8" z.21	173	6 13/16"	143.5	5 21/32"	26	1 1/32"	900	7950	148.352.002.1	
	W42	1 3/8" z.6	173	6 13/16"	158.5	6 15/64"	26	1 1/32"	1100	9700	148.354.001.1	
	W43	1 3/8" z.21	173	6 13/16"	158.5	6 15/64"	26	1 1/32"	1100	9700	148.354.002.1	
	W44	1 3/4" z.6	173	6 13/16"	183.5	7 7/32"	28	1 7/64"	1100	9700	148.354.003.1	
60	W45	1 3/4" z.20	173	6 13/16"	183.5	7 7/32"	28	1 7/64"	1100	9700	148.354.004.1	
	W22	1 3/8" z.6	173	6 13/16"	150.5	5 59/64"	26	1 1/32"	900	7950	148.362.001.1	
	W23	1 3/8" z.21	173	6 13/16"	150.5	5 59/64"	26	1 1/32"	900	7950	148.362.002.1	
	W42	1 3/8" z.6	173	6 13/16"	165.5	6 33/64"	26	1 1/32"	1100	9700	148.364.002.1	
	W43	1 3/8" z.21	173	6 13/16"	165.5	6 33/64"	26	1 1/32"	1100	9700	148.364.005.1	
	W44	1 3/4" z.6	173	6 13/16"	190.5	7 1/2"	28	1 7/64"	1100	9700	148.364.018.1	
	W45	1 3/4" z.20	173	6 13/16"	190.5	7 1/2"	28	1 7/64"	1100	9700	148.364.015.1	
	W42	1 3/8" z.6	173	6 13/16"	165.5	6 33/64"	26	1 1/32"	1500	13250	148.364.001.1	
	W43	1 3/8" z.21	173	6 13/16"	165.5	6 33/64"	26	1 1/32"	1500	13250	148.364.004.1	
	W44	1 3/4" z.6	173	6 13/16"	190.5	7 1/2"	28	1 7/64"	1500	13250	148.364.019.1	
	W45	1 3/4" z.20	173	6 13/16"	190.5	7 1/2"	28	1 7/64"	1500	13250	148.364.016.1	
80	W42	1 3/8" z.6	173	6 13/16"	173.5	6 53/64"	26	1 1/32"	1100	9700	148.384.001.1	
	W43	1 3/8" z.21	173	6 13/16"	173.5	6 53/64"	26	1 1/32"	1100	9700	148.384.002.1	
	W44	1 3/4" z.6	173	6 13/16"	198.5	7 13/16"	28	1 7/64"	1100	9700	148.384.007.1	
	W45	1 3/4" z.20	173	6 13/16"	198.5	7 13/16"	28	1 7/64"	1100	9700	148.384.008.1	
	W42	1 3/8" z.6	173	6 13/16"	173.5	6 53/64"	26	1 1/32"	1500	13250	148.384.003.1	
	W43	1 3/8" z.21	173	6 13/16"	173.5	6 53/64"	26	1 1/32"	1500	13250	148.384.004.1	
	W44	1 3/4" z.6	173	6 13/16"	198.5	7 13/16"	28	1 7/64"	1500	13250	148.384.009.1	
	W45	1 3/4" z.20	173	6 13/16"	198.5	7 13/16"	28	1 7/64"	1500	13250	148.384.010.1	
	W42	1 3/8" z.6	173	6 13/16"	173.5	6 53/64"	26	1 1/32"	1800	15900	148.384.005.1	
	W43	1 3/8" z.21	173	6 13/16"	173.5	6 53/64"	26	1 1/32"	1800	15900	148.384.006.1	
	W44	1 3/4" z.6	173	6 13/16"	198.5	7 13/16"	28	1 7/64"	1800	15900	148.384.011.1	
W45	1 3/4" z.20	173	6 13/16"	198.5	7 13/16"	28	1 7/64"	1800	15900	148.384.012.1		

FRIZIONE CHIUSA A DICHI MULTIPLI CLOSED DISC CLUTCH TORQUE LIMITER



La frizione "chiusa" a dischi multipli W interviene quando la coppia di lavoro supera la coppia di taratura. Durante la fase di limitazione del picco di coppia la frizione continua a trasmettere potenza. La frizione è utilizzabile sia come dispositivo di sicurezza contro picchi di coppia sia per avviare macchine con elevata inerzia rotazionale. Questo tipo di frizione risulta avere la taratura non modificabile ed inoltre l'utilizzo di speciali molle a tazza in luogo delle più comuni molle elicoidali rende costante la taratura nonostante il progressivo consumo dei dischi d'attrito.

The closed disc clutch torque limiter W is activated when the setting torque exceeds the calibration torque. During the torque peak limiting phase, the clutch keeps on transmitting power. The clutch can be used Both as safety device to protect against load peaks and to start machines with high rotational inertia. The torque setting of this clutch is not adjustable and the use of special Belleville springs instead of the helical springs ensures a stable torque setting compensating for the natural wear of the friction linings.

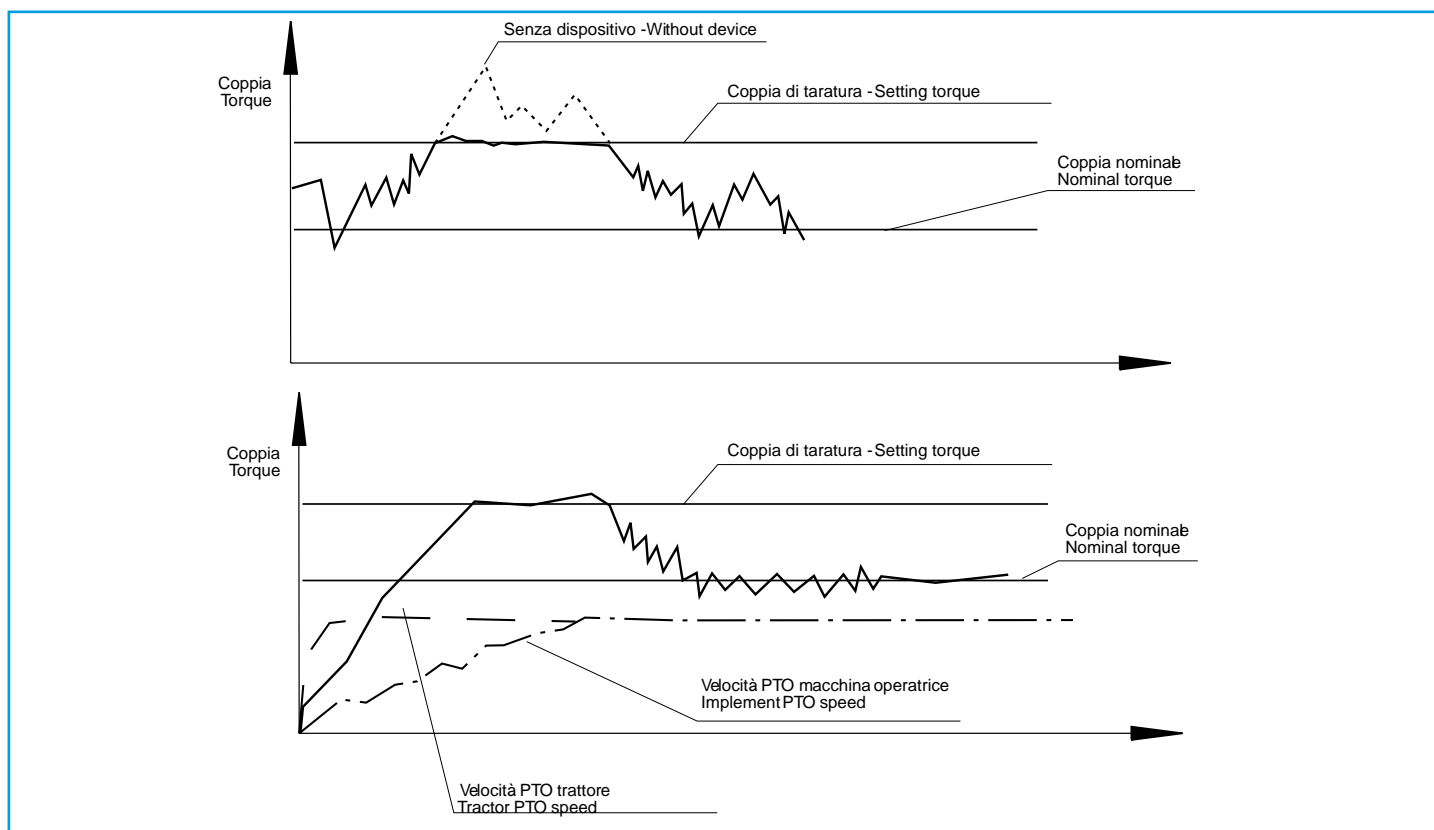

Le frizioni possono raggiungere elevate temperature.

Non toccare!

Per evitare rischi di incendio, mantenere la zona adiacente la frizione pulita da materiale infiammabile ed evitare slittamenti prolungati.

Friction clutches may become hot during use.

Do not touch!

Keep the area around the friction clutch clear of any material which could catch fire and avoid prolonged slipping.



W22/W23

W

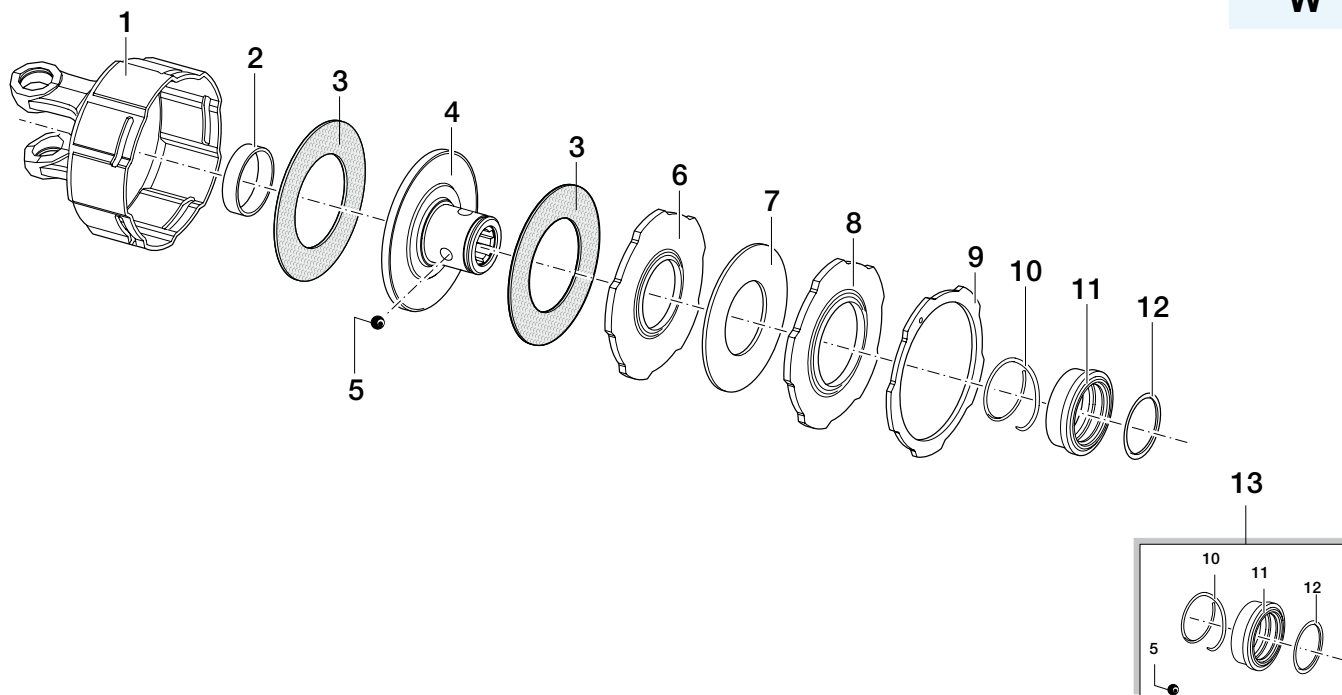

Pos.	Description		Code	Qty *
1	Forcella corpo W2 (tipo 20)	Yoke support W2 (type 20)	141.022.371.1	1
	Forcella corpo W2 (tipo 40)	Yoke support W2 (type 40)	141.024.484.1	1
	Forcella corpo W2 (tipo 50)	Yoke support W2 (type 50)	141.025.387.1	1
	Forcella corpo W2 (tipo 60)	Yoke support W2 (type 60)	141.026.601.1	1
2	Bronzina	Bush	180.019.019	1
3	Disco attrito ø152xø90	Lining rings ø152xø90	180.019.018	2
4	Mozzo W22	Hub W22	151.017.281	1
	Mozzo W23	Hub W23	151.017.296	1
5	Sfere 1/2"	Ball 1/2"	190.000.078	3
6	Disco stringifrizione W (600 Nm)	Pressure plate W (600 Nm)	180.017.282	1
	Disco stringifrizione W (750 Nm)	Pressure plate W (750 Nm)	180.017.270	1
	Disco stringifrizione W (900 Nm)	Pressure plate W (900 Nm)	180.017.282	1
7	Molla a tazza (600 Nm)	Belleville spring (600 Nm)	190.000.594	1
	Molla a tazza (750 Nm)	Belleville spring (750 Nm)	190.000.594	1
	Molla a tazza (900 Nm)	Belleville spring (900 Nm)	190.000.607	1
8	Disco di reazione	Reaction ring	180.017.269	1
9	Disco d'arresto	Stop ring	180.017.276	1
10	Molla collar	Collar spring	180.016.487	1
11	Manicotto collar	Sliding sleeve collar	151.016.486	1
12	Seeger	Snap ring	190.000.451	1
13	Kit collar	Kit Collar	165.000.719	1

* Quantità presente nel dispositivo
 Quantity in the Safety Device



W42/W43

W

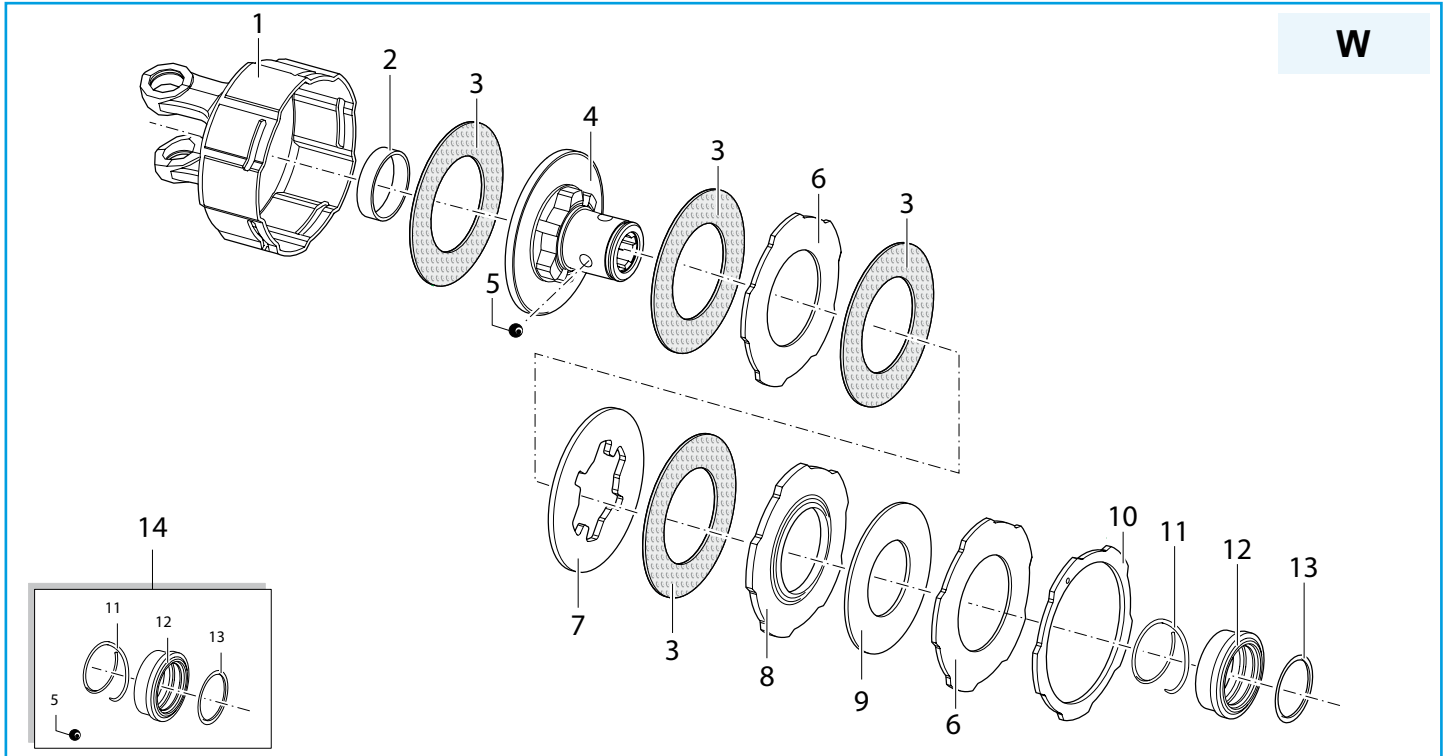

Pos.	Description		Code	Qty *
1	Forcella corpo W4 (tipo 50)	Yoke support W4 (type 50)	141.025.388.1	1
	Forcella corpo W4 (tipo 60)	Yoke support W4 (type 60)	141.026.593.1	1
	Forcella corpo W4 (tipo 80)	Yoke support W4 (type 80)	141.028.487.1	1
2	Bronzina	Bush	180.019.019	1
3	Disco attrito $\phi 152 \times \phi 90$	Lining ring $\phi 152 \times \phi 90$	180.019.018	4
4	Mozzo W42	Hub W42	151.019.158	1
	Mozzo W43	Hub W43	151.017.297	1
5	Sfere 1/2"	Ball 1/2"	190.000.078	3
6	Disco intermedio	Inner plate	180.017.269	2
7	Disco sagomato	Intermediate plate	180.019.115	1
8	Disco stringifrizione W (1100 Nm)	Pressure plate W (1100 Nm)	180.017.282	1
	Disco stringifrizione W (1500 Nm)	Pressure plate W (1500 Nm)	180.017.282	1
	Disco stringifrizione W (1800 Nm)	Pressure plate W (1800 Nm)	180.013.451	1
9	Molla a tazza (1100 Nm)	Belleville spring (1100 Nm)	190.000.594	1
	Molla a tazza (1500 Nm)	Belleville spring (1500 Nm)	190.000.607	1
	Molla a tazza (1800 Nm)	Belleville spring (1800 Nm)	190.000.855	1
10	Disco d' arresto	Stop ring	180.017.276	1
11	Molla collar	Collar spring	180.016.487	1
12	Manicotto collar	Sliding sleeve collar	151.016.486	1
13	Seeger	Snap ring	190.000.451	1
14	Kit collar	Kit collar	165.000.719	1

Dispositivi di sicurezza integrali
Integral Safety Devices

* Quantità presente nel dispositivo
Quantity in the Safety Device



W44/W45

W

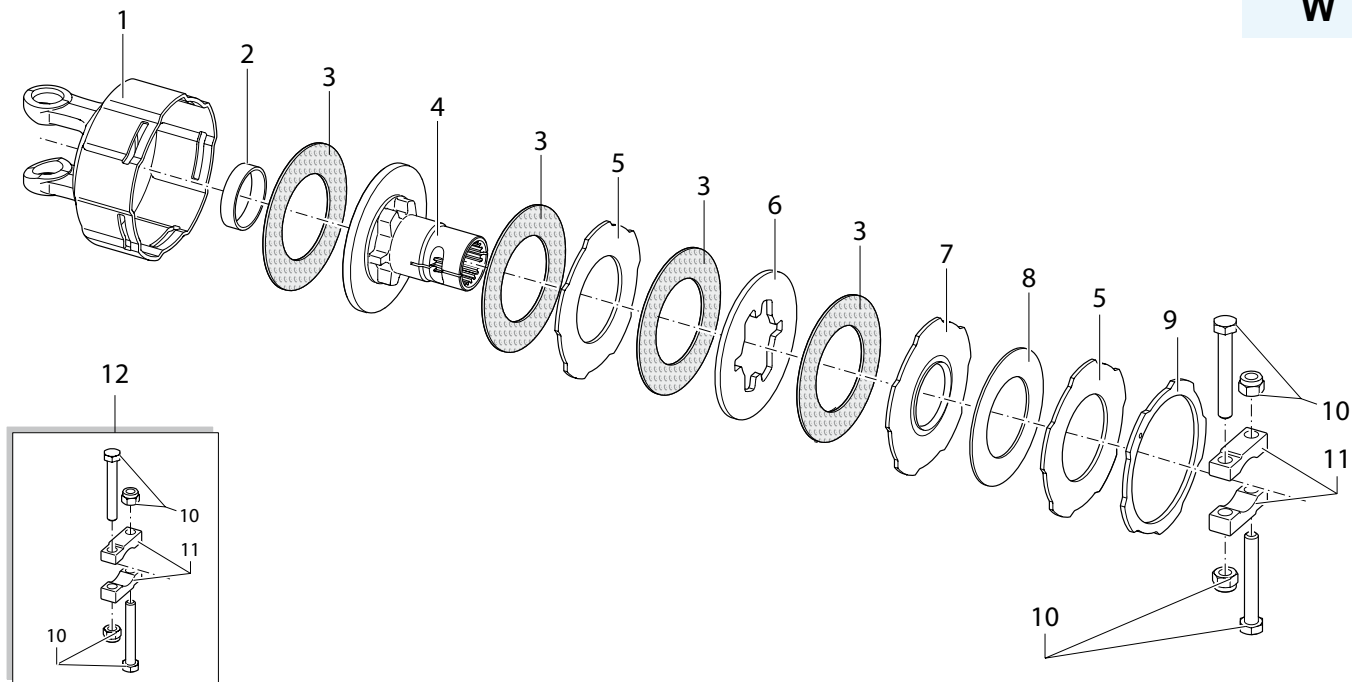

Pos.	Description		Code	Qty *
1	Forcella corpo W4 (tipo 50)	Yoke support W4 (type 50)	141.025.388.1	1
	Forcella corpo W4 (tipo 60)	Yoke support W4 (type 60)	141.026.593.1	1
	Forcella corpo W4 (tipo 80)	Yoke support W4 (type 80)	141.028.487.1	1
2	Bronzina	Bush	180.019.019	1
3	Disco attrito $\phi 152 \times \phi 90$	Lining ring $\phi 152 \times \phi 90$	180.019.018	4
4	Mozzo W44	Hub W44	151.017.390	1
	Mozzo W45	Hub W45	151.017.366	1
5	Disco intermedio	Inner plate	180.017.269	2
6	Disco sagomato	Intermediate plate	180.019.115	1
7	Disco stringifrizione W (1100 Nm)	Pressure plate W (1100 Nm)	180.017.282	1
	Disco stringifrizione W (1500 Nm)	Pressure plate W (1500 Nm)	180.017.282	1
	Disco stringifrizione W (1800 Nm)	Pressure plate W (1800 Nm)	180.013.451	1
8	Molla a tazza (1100 Nm)	Belleville spring (1100 Nm)	190.000.594	1
	Molla a tazza (1500 Nm)	Belleville spring (1500 Nm)	190.000.607	1
	Molla a tazza (1800 Nm)	Belleville spring (1800 Nm)	190.000.855	1
9	Disco d'arresto	Stop ring	180.017.276	1
10	Vite M14x1,5x100 e dado	Bolt M14x1,5x100+nut	165.000.622	2
11	Ponti di blocco	Clamp lock	151.014.201	2
12	Kit ponti di blocco 3/4"	Clamp lock set 1 3/4"	165.000.692	1

* Quantit  presente nel dispositivo
 Quantity in the Safety Device

LIMITATORE A BULLONE DI TRANCIO CON RUOTA LIBERA SHEAR BOLT TORQUE LIMITER WITH OVERRUNNING CLUTCH

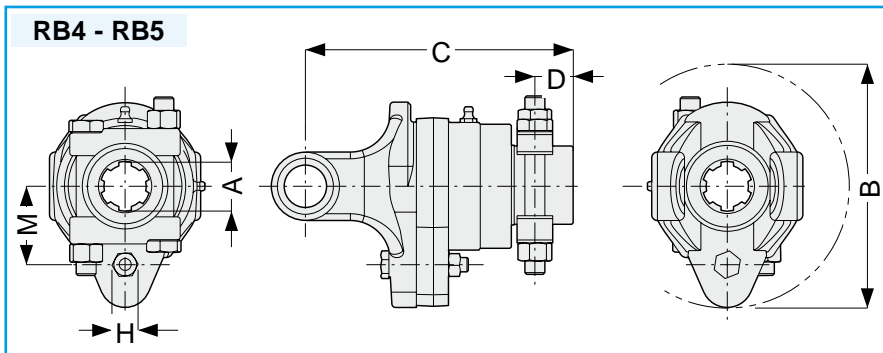
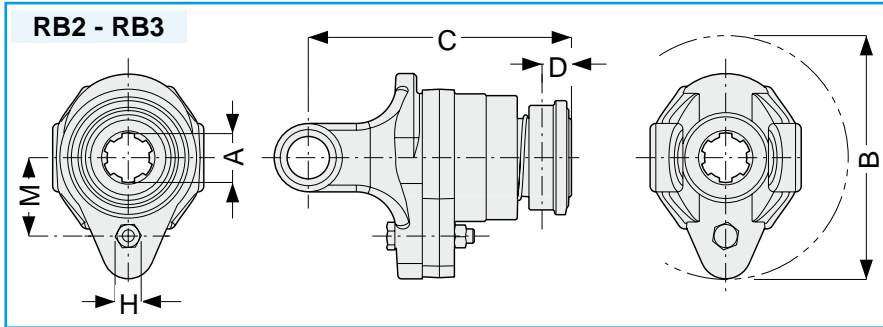
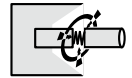

Type	Ref.	A		B		C		D		M		MAX		H ISO 8.8	Code
		[mm]	[inch]	[mm]	[inch]	[mm]	[inch]	[mm]	[inch]	[mm]	[inch]	[Nm]	[in.lb]		
40	RB2	1 3/8"	z.6	134	5 9/32"	180	7 3/32"	26	1 1/32"	55	2 11/64"	1700	15000	M8x50	143.340.001.1
	RB3	1 3/8"	z.21	134	5 9/32"	180	7 3/32"	26	1 1/32"	55	2 11/64"	1700	15000	M8x50	143.340.002.1
50	RB2	1 3/8"	z.6	134	5 9/32"	180	7 3/32"	26	1 1/32"	55	2 11/64"	2100	18500	* M8x50	143.350.001.1
	RB3	1 3/8"	z.21	134	5 9/32"	180	7 3/32"	26	1 1/32"	55	2 11/64"	2100	18500	* M8x50	143.350.002.1
60	RB2	1 3/8"	z.6	162	6 3/8"	187	7 23/64"	26	1 1/32"	55	2 11/64"	2500	22100	M10x60	143.360.001.1
	RB3	1 3/8"	z.21	162	6 3/8"	187	7 23/64"	26	1 1/32"	55	2 11/64"	2500	22100	M10x60	143.360.002.1
	RB4	1 3/4"	z.6	162	6 3/8"	187	7 23/64"	28	1 7/64"	55	2 11/64"	2500	22100	M10x60	143.360.003.1
	RB5	1 3/4"	z.20	162	6 3/8"	187	7 23/64"	28	1 7/64"	55	2 11/64"	2500	22100	M10x60	143.360.004.1
80	RB2	1 3/8"	z.6	162	6 3/8"	197	7 3/4"	26	1 1/32"	57	2 1/4"	3500	30900	M12x65	143.380.001.1
	RB3	1 3/8"	z.21	162	6 3/8"	197	7 3/4"	26	1 1/32"	57	2 1/4"	3500	30900	M12x65	143.380.002.1
	RB4	1 3/4"	z.6	162	6 3/8"	197	7 3/4"	28	1 7/64"	57	2 1/4"	3500	30900	M12x65	143.380.003.1
	RB5	1 3/4"	z.20	162	6 3/8"	197	7 3/4"	28	1 7/64"	57	2 1/4"	3500	30900	M12x65	143.380.004.1

* Resistenza della vite 10.9
Bolt material 10.9

NOTA: fornibile a richiesta per senso di rotazione antiorario

Il dispositivo comprende un limitatore di coppia a bullone di trancio e una ruota libera integrati. La funzionalità del dispositivo assomma quelle dei singoli dispositivi con il vantaggio di una riduzione di spazio e il montaggio da un solo lato del cardano.

NOTE: available upon request for anti-clockwise direction of rotation

The device includes a shear bolt torque limiter and incorporated overrunning clutch. The device combines the functions of all the single devices with the advantage of reduced space and assembly on only one side of the cardan shaft.

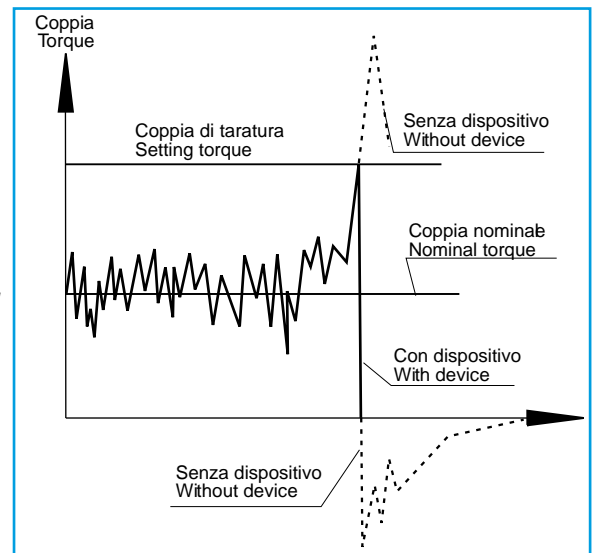

Dispositivi di sicurezza integrali
Integral Safety Devices

LIMITATORE A BULLONE DI TRANCIO CON RUOTA LIBERA SHEAR BOLT TORQUE LIMITER WITH OVERRUNNING CLUTCH



RB

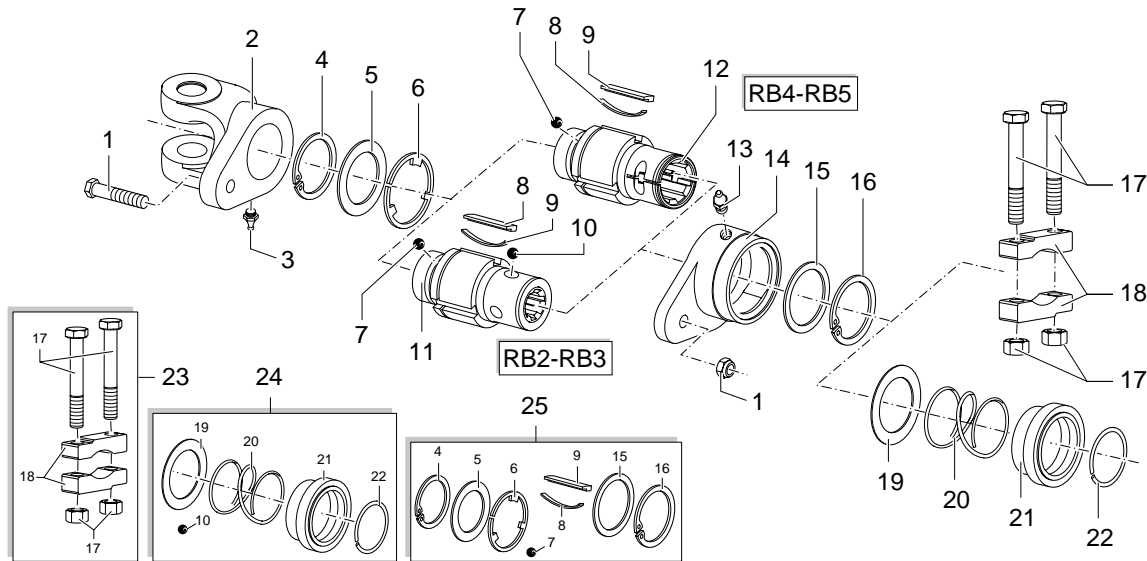

Pos.	Description		Code	Qty *
1	Vite M8x50+dado (tipo 40)	Bolt M8x50+nut (type 40)	165.000.505	1
	Vite M8x50(cl.10.9)+dado (tipo 50)	Bolt M8x50(cl,10,9)+nut (type 50)	165.000.626	1
	Vite M10x60+dado (tipo 60)	Bolt M10x60+nut (type 60)	165.000.507	1
	Vite M12x65+dado (tipo 80)	Bolt M12x65+nut (type 80)	165.000.512	1
2	Forcella RB (tipo 40)	Yoke RB (type 40)	151.014.389.1	1
	Forcella RB (tipo 50)	Yoke RB (type 50)	151.015.342.1	1
	Forcella RB (tipo 60)	Yoke RB (type 60)	151.016.042.1	1
	Forcella RB (tipo 80)	Yoke RB (type 80)	151.018.023.1	1
3	Ingrassatore M8x1 (tipo 40-50)	Greaser M8x1 (type 40-50)	190.000.020	1
	Ingrassatore M10x1 (tipo 60-80)	Greaser M10x1 (type 60-80)	190.000.021	1
4	Seeger	Circlip	190.000.178	1
5	Anello di rasamento	Retaining washer ring	190.000.435	1
6	Anello di tenuta	Gasket	180.014.393	1
7	Sfera 1/4" (tipo 40-50)	Ball 1/4" (type 40-50)	190.000.022	25
	Sfera 5/16" (tipo 60-80)	Ball 5/16" (type 60-80)	190.000.023	24
8	Molla a balestra	Leaf spring	180.014.137	3
9	Linguetta	Ratchet	151.014.136	3
10	Sfera 1/2"	Ball 1/2"	190.000.078	3
11	Mozzo RB2 (tipo 40-50)	Hub RB2 (type 40-50)	151.014.432	1
	Mozzo RB2 (tipo 60-80)	Hub RB2 (type 60-80)	151.016.580	1
	Mozzo RB3 (tipo 40-50)	Hub RB3 (type 40-50)	151.014.486	1
	Mozzo RB3 (tipo 60-80)	Hub RB3 (type 60-80)	151.016.631	1
12	Mozzo RB4 (tipo 60-80)	Hub RB4 (type 60-80)	151.016.542	1
	Mozzo RB5 (tipo 60-80)	Hub RB5 (type 60-80)	151.016.507	1
13	Ingrassatore M8x1	Greaser M8x1	190.000.020	1
14	Corpo RB (tipo 40-50)	Torque limiter support RB (type 40-50)	151.014.390.1	1
	Corpo RB (tipo 60)	Torque limiter support RB (type 60)	151.016.441.1	1
	Corpo RB (tipo 80)	Torque limiter support RB (type 80)	151.018.363.1	1
15	Anello di rasamento	Retaining washer ring	180.014.135	1
16	Seeger	Circlip	190.000.183	1
17	Kit vite M14x1,5x100 + dado	Bolt M14x1,5x100+nut	165.000.622	2
18	Ponte di blocco	Clamp lock	151.014.201	2
19	Lamierino	Spring push ring	180.015.143	1
20	Molla collar	Collar spring	180.016.487	1
21	Manicotto collar	Sliding sleeve Collar	151.016.486	1
22	Seeger	Snap ring	190.000.451	1
23	Kit ponti blocco 1 3/4"	Clamp lock set 1 3/4"	165.000.692	1
24	Kit collar R12-R13	Kit Collar R12-R13	165.000.653	1
25	Kit RB 40-50	Kit RB 40-50	165.000.726	1
	Kit RB 60-80	Kit RB 60-80	165.000.770	1

* Quantità presente nel dispositivo
Quantity in the Safety Device

FRIZIONE A DISCHI MULTIPLI CON RUOTA LIBERA DISC CLUTCH TORQUE LIMITER WITH OVERRUNNING CLUTCH

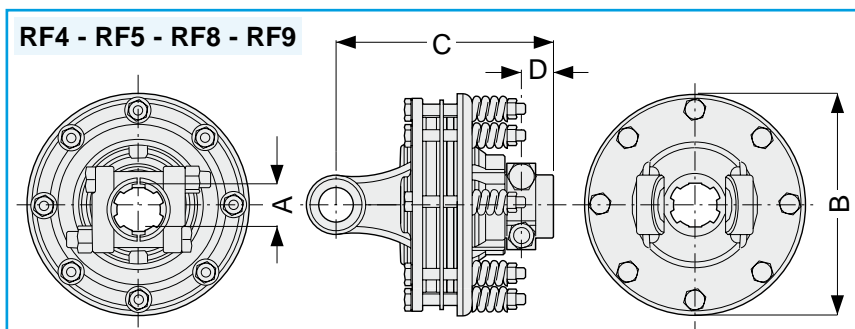
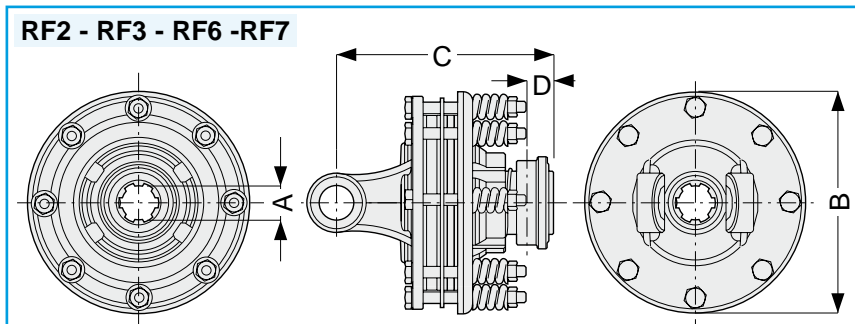

Type	Ref.	A		B		C		D		MAX		Code
		[mm]	[inch]	[mm]	[inch]	[mm]	[inch]	[mm]	[inch]	[Nm]	[in.lb]	
40	RF2	1 3/8"	z.6	195	7 43/64"	175	6 57/64"	26	1 3/32"	900	7950	146.342.001.1
	RF3	1 3/8"	z.21	195	7 43/64"	175	6 57/64"	26	1 3/32"	900	7950	146.342.002.1
	RF4	1 3/4"	z.6	195	7 43/64"	175	6 57/64"	28	1 7/64"	900	7950	146.342.003.1
	RF5	1 3/4"	z.20	195	7 43/64"	175	6 57/64"	28	1 7/64"	900	7950	146.342.004.1
50	RF2	1 3/8"	z.6	195	7 43/64"	175	6 57/64"	26	1 3/32"	900	7950	146.352.001.1
	RF3	1 3/8"	z.21	195	7 43/64"	175	6 57/64"	26	1 3/32"	900	7950	146.352.002.1
	RF4	1 3/4"	z.6	195	7 43/64"	175	6 57/64"	28	1 7/64"	900	7950	146.352.003.1
	RF5	1 3/4"	z.20	195	7 43/64"	175	6 57/64"	28	1 7/64"	900	7950	146.352.004.1
	RF6	1 3/8"	z.6	195	7 43/64"	190	7 31/64"	26	1 1/32"	1200	10600	146.354.001.1
	RF7	1 3/8"	z.21	195	7 43/64"	190	7 31/64"	26	1 1/32"	1200	10600	146.354.002.1
60	RF8	1 3/4"	z.6	195	7 43/64"	190	7 31/64"	28	1 7/64"	1200	10600	146.354.003.1
	RF9	1 3/4"	z.20	195	7 43/64"	190	7 31/64"	28	1 7/64"	1200	10600	146.354.004.1
	RF6	1 3/8"	z.6	195	7 43/64"	190	7 31/64"	26	1 1/32"	1400	12400	146.364.001.1
	RF7	1 3/8"	z.21	195	7 43/64"	190	7 31/64"	26	1 1/32"	1400	12400	146.364.002.1
80	RF8	1 3/4"	z.6	195	7 43/64"	190	7 31/64"	28	1 7/64"	1400	12400	146.364.003.1
	RF9	1 3/4"	z.20	195	7 43/64"	190	7 31/64"	28	1 7/64"	1400	12400	146.364.004.1
	RF6	1 3/8"	z.6	195	7 43/64"	203	7 63/64"	26	1 1/32"	1400	12400	146.384.001.1
	RF7	1 3/8"	z.21	195	7 43/64"	203	7 63/64"	26	1 1/32"	1400	12400	146.384.002.1
90	RF8	1 3/4"	z.6	195	7 43/64"	203	7 63/64"	28	1 7/64"	1400	12400	146.384.003.1
	RF9	1 3/4"	z.20	195	7 43/64"	203	7 63/64"	28	1 7/64"	1400	12400	146.384.004.1
	RF6	1 3/8"	z.6	195	7 43/64"	203	7 63/64"	26	1 1/32"	1400	12400	146.394.001.1
	RF7	1 3/8"	z.21	195	7 43/64"	203	7 63/64"	26	1 1/32"	1400	12400	146.394.002.1
90	RF8	1 3/4"	z.6	195	7 43/64"	203	7 63/64"	28	1 7/64"	1400	12400	146.394.003.1
	RF9	1 3/4"	z.20	195	7 43/64"	203	7 63/64"	28	1 7/64"	1400	12400	146.394.004.1

NOTA: fornibile a richiesta per senso di rotazione antiorario
NOTE: available upon request for anti-clockwise direction of rotation

FRIZIONE A DISCHI MULTIPLI CON RUOTA LIBERA DISC CLUTCH TORQUE LIMITER WITH OVERRUNNING CLUTCH



Il dispositivo comprende un limitatore di coppia a dischi d'attrito (frizione) e una ruota libera integrati. La funzionalità assomma quelle dei singoli dispositivi con il vantaggio di risparmiare spazio e di consentire il montaggio sullo stesso lato del cardano. Il dispositivo è utile come organo di sicurezza contro picchi di carico e in macchine con grosse masse rotanti, sia durante l'avviamento che durante l'arresto, evitando inutili sollecitazioni della PTO del trattore. E' importante il controllo della taratura della frizione per assicurare un corretto funzionamento del dispositivo.

The device includes a disc clutch torque limiter and an incorporated overruning clutch. The device combines the functions of the single devices thus reducing space and allowing it to be mounted on the same side of the cardan. It is useful as a safety device to protect against load peaks and in implements with large rotating mass during start-up and stopping operations, thus avoiding unnecessary stress on the tractor PTO. It is recommended to ensure the setting value is correct.

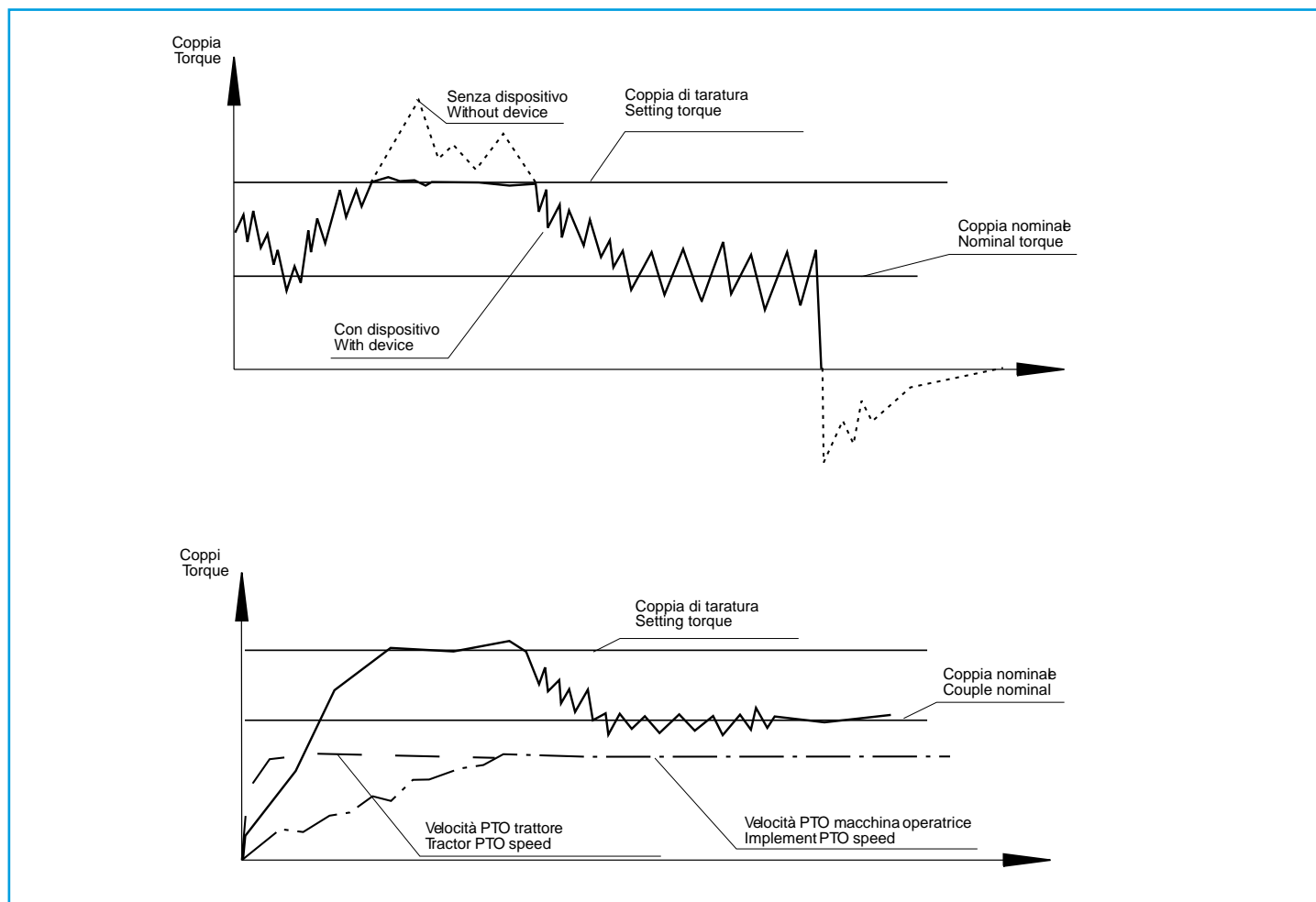

Le frizioni possono raggiungere elevate temperature.

Non toccare!

Per evitare rischi di incendio, mantenere la zona adiacente la frizione pulita da materiale infiammabile ed evitare slittamenti prolungati.

Friction clutches may become hot during use.

Do not touch!

Keep the area around the friction clutch clear of any material which could catch fire and avoid prolonged slipping.

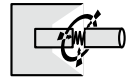

RF2/RF3

RF

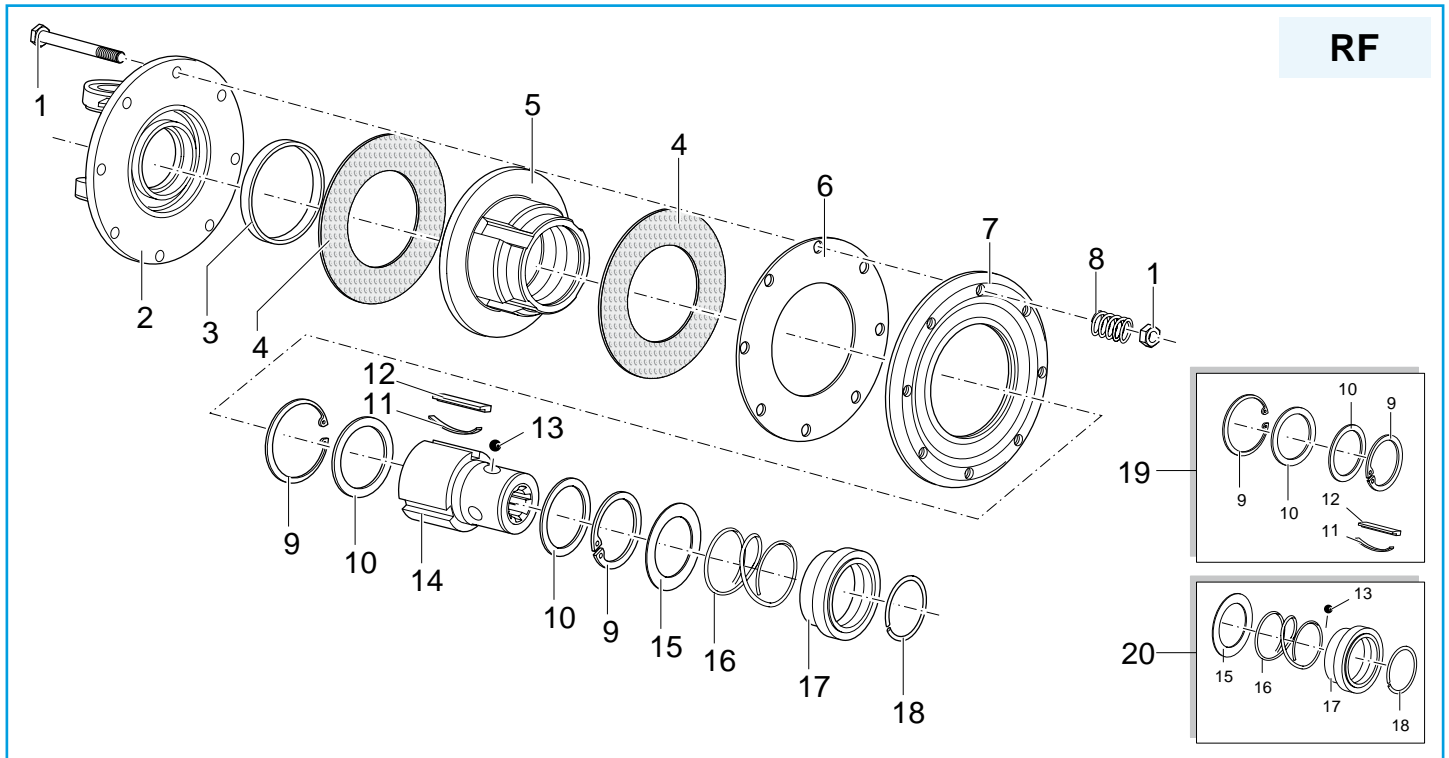

Pos.	Description		Code	Qty *
1	Bullone M10x85 + dado	Bolt M10x85+nut	165.000.549	8
2	Forcella flangia RF (tipo 40)	Flanged yoke RF (type 40)	141.024.353.1	1
	Forcella flangia RF (tipo 50)	Flanged yoke RF (type 50)	141.025.326.1	1
3	Bronzina	Bush	180.017.112	1
4	Disco attrito $\phi 152 \times \phi 102$	Lining ring $\phi 152 \times \phi 102$	180.017.527	2
5	Corpo	Torque limiter support	141.025.330	1
6	Disco intermedio	Inner plate	180.017.105	1
7	Disco stringifrizione	Pressure plate	180.017.114.1	1
8	Molla $\phi 6$	Spring $\phi 6$	180.014.022	8
9	Seeger	Circlip	190.000.183	2
10	Anello di rasamento	Retaining washer ring	180.014.135	2
11	Molla a balestra	Leaf spring	180.014.137	3
12	Linguetta	Ratchet	151.014.136	3
13	Sfera 1/2"	Ball 1/2"	190.000.078	3
14	Mozzo R12	Hub R12	151.016.546	1
	Mozzo R13	Hub R13	151.016.571	1
15	Lamierino	Spring push ring	180.015.143	1
16	Molla collar	Collar spring	180.016.487	1
17	Manicotto collar	Sliding sleeve Collar	151.016.486	1
18	Seeger	Snap ring	190.000.451	1
19	Kit RF	Kit RF	165.000.741	1
20	Kit collar R12-R13	Kit Collar R12-R13	165.000.653	1

* Quantità presente nel dispositivo
 Quantity in the Safety Device



RF4/RF5

RF

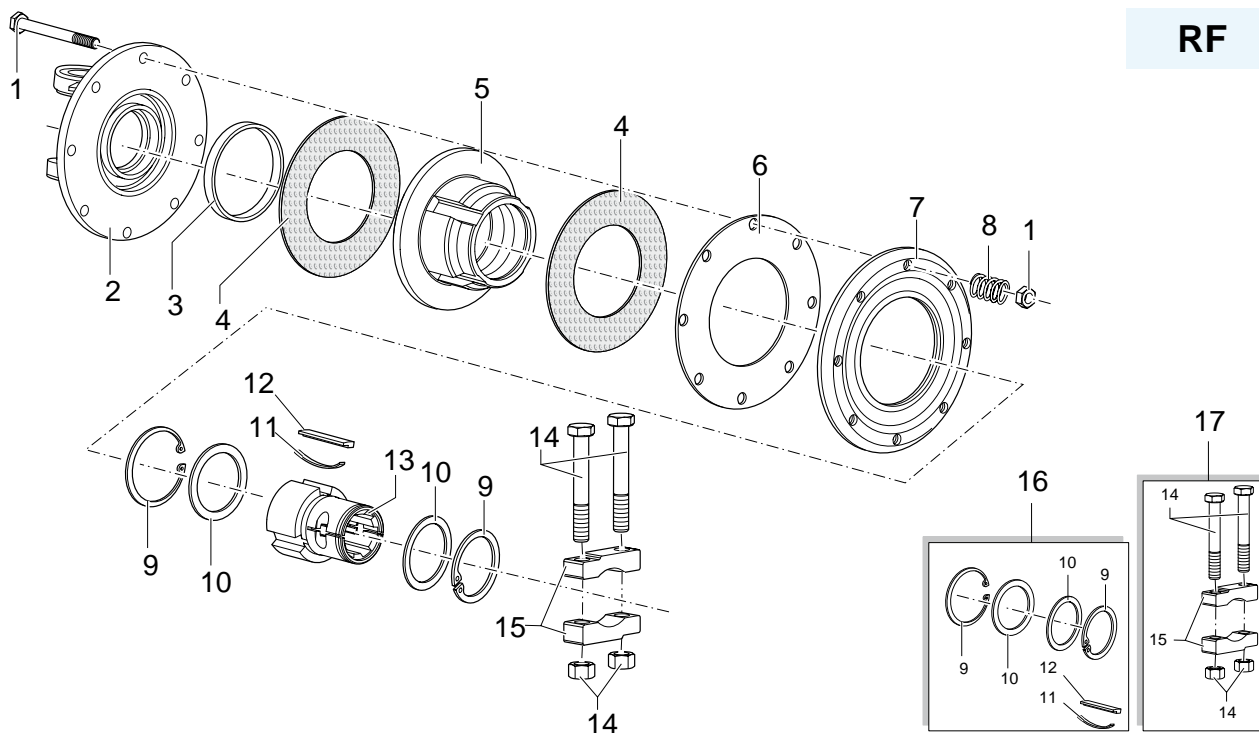

Pos.	Description		Code	Qty *
1	Bullone M10x85 + dado	<i>Bolt M10x85+nut</i>	165.000.549	8
2	Forcella flangia RF (tipo 40)	<i>Flanged yoke RF (type 40)</i>	141.024.353.1	1
	Forcella flangia RF (tipo 50)	<i>Flanged yoke RF (type 50)</i>	141.025.326.1	1
3	Bronzina	<i>Bush</i>	180.017.112	1
4	Disco affrifo $\phi 152 \times \phi 102$	<i>Lining ring $\phi 152 \times \phi 102$</i>	180.017.527	2
5	Corpo	<i>Torque limiter support</i>	141.025.330	1
6	Disco intermedio	<i>Inner plate</i>	180.017.105	1
7	Disco sfringifrizione	<i>Pressure plate</i>	180.017.114.1	1
8	Molla $\phi 6$	<i>Spring $\phi 6$</i>	180.014.022	8
9	Seeger	<i>Circlip</i>	190.000.183	2
10	Anello di rasamenfo	<i>Retaining washer ring</i>	180.014.135	2
11	Molla a balestra	<i>Leaf spring</i>	180.014.137	3
12	Linguetta	<i>Ratchet</i>	151.014.136	3
13	Mozzo R14	<i>Hub R14</i>	151.014.200	1
	Mozzo R15	<i>Hub R15</i>	151.018.121	1
14	Vite M14x1,5x100 + dado	<i>Bolt M14x1,5x100+nut</i>	165.000.622	2
15	Ponte di blocco	<i>Clamp lock</i>	151.014.201	2
16	Kit RF	<i>Kit RF</i>	165.000.741	1
17	Kit ponti blocco 1 3/4"	<i>Clamp lock set 1 3/4"</i>	165.000.692	1

* Quantità presente nel dispositivo
 Quantity in the Safety Device



RF6/RF7

RF

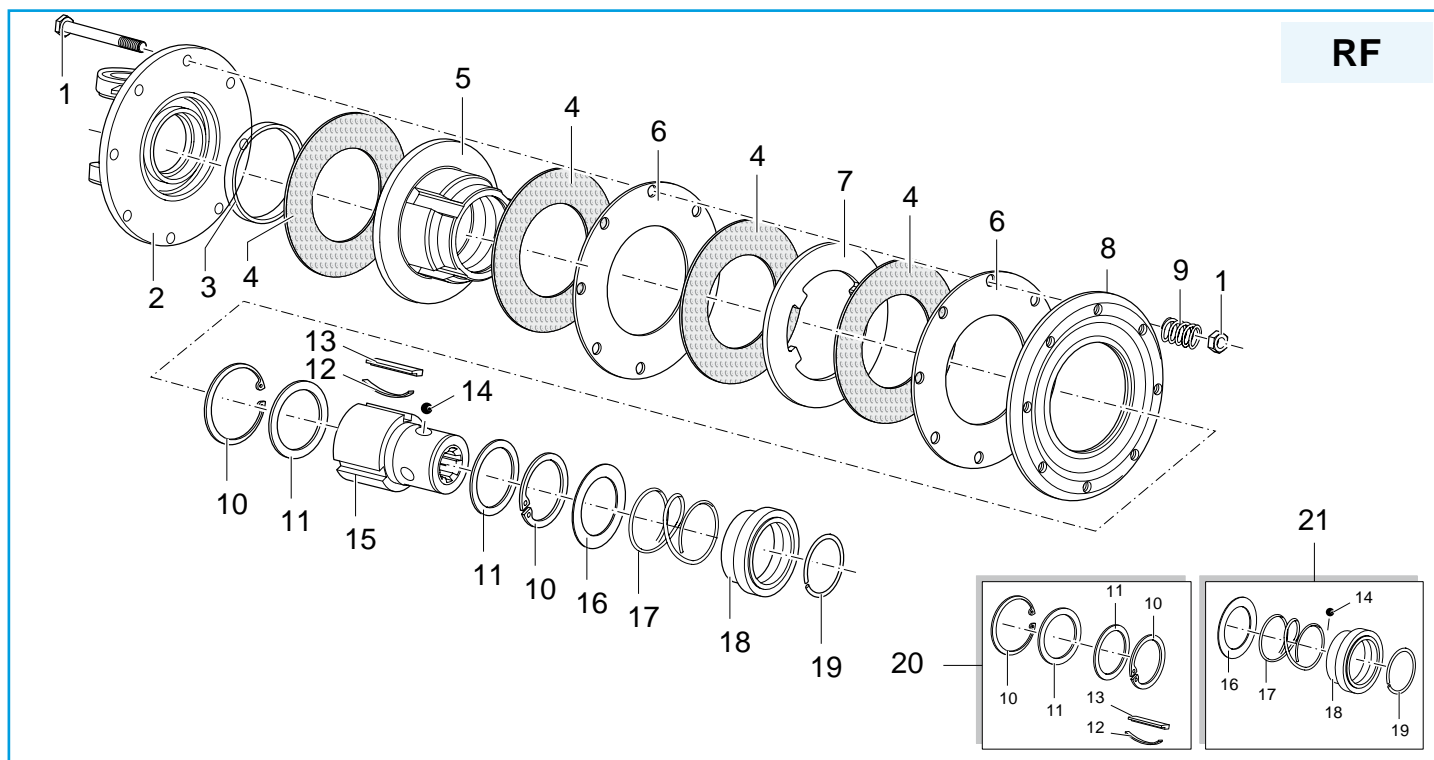

Pos.	Description		Code	Qty *
1	Bullone M10x100 + dado	Bolt M10x100+nut	165.000.548	8
2	Forcella flangia RF (tipo 50)	Flanged yoke RF (type 50)	141.025.326.1	1
	Forcella flangia RF (tipo 60)	Flanged yoke RF (type 60)	141.026.347.1	1
	Forcella flangia RF (tipo 80)	Flanged yoke RF (type 80)	141.028.220.1	1
	Forcella flangia RF (tipo 90)	Flanged yoke RF (type 90)	141.029.159.1	1
3	Bronzina	Bush	180.017.112	1
4	Disco attrito $\varnothing 152 \times \varnothing 102$	Lining ring $\varnothing 152 \times \varnothing 102$	180.017.527	4
5	Corpo	Torque limiter support	141.027.107	1
6	Disco intermedio	Inner plate	180.017.105	2
7	Disco sagomato	Intermediate plate	180.017.104	1
8	Disco stringifrizione	Pressure plate	180.017.114.1	1
9	Molla $\varnothing 6$	Spring $\varnothing 6$	180.014.022	8
10	Seeger	Circlip	190.000.183	2
11	Anello di rasamento	Retaining washer ring	180.014.135	2
12	Molla a balestra	Leaf spring	180.014.137	3
13	Linguetta	Ratchet	151.014.136	3
14	Sfera 1/2"	Ball 1/2"	190.000.078	3
15	Mozzo R12	Hub R12	151.016.546	1
	Mozzo R13	Hub R13	151.016.571	1
16	Lamierino	Spring push ring	180.015.143	1
17	Molla collar	Collar spring	180.016.487	1
18	Manicotto collar	Sliding sleeve collar	151.016.486	1
19	Seeger	Snap ring	190.000.451	1
20	Kit RF	Kit RF	165.000.741	1
21	Kit collar R12-R13	Kit collar R12-R13	165.000.653	1

* Quantità presente nel dispositivo
 Quantity in the Safety Device



RF8/RF9

RF

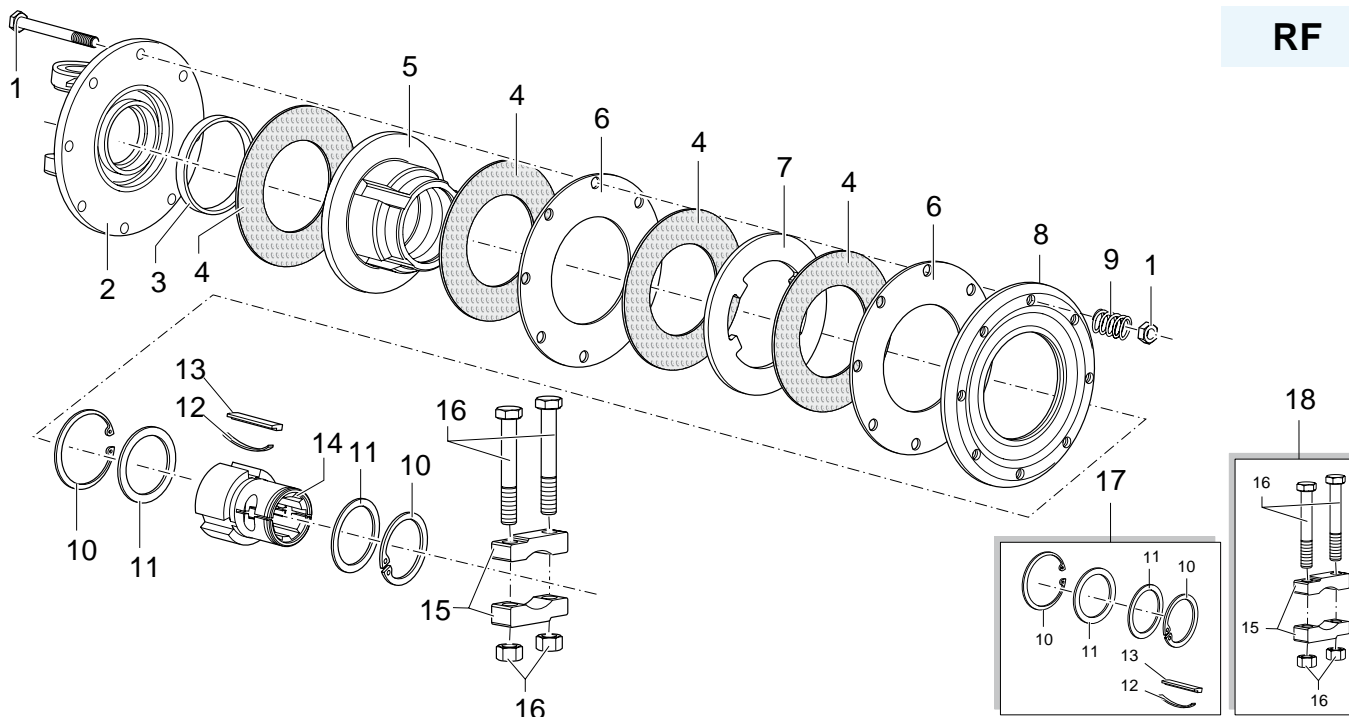

Pos.	Description		Code	Qty *
1	Bullone M10x100 + dado	Bolt M10x100+nut	165.000.548	8
2	Forcella flangia RF (tipo 50)	Flanged yoke RF (type 50)	141.025.326.1	1
	Forcella flangia RF (tipo 60)	Flanged yoke RF (type 60)	141.026.347.1	1
	Forcella flangia RF (tipo 80)	Flanged yoke RF (type 80)	141.028.220.1	1
	Forcella flangia RF (tipo 90)	Flanged yoke RF (type 90)	141.029.159.1	1
3	Bronzina	Bush	180.017.112	1
4	Disco attrito $\phi 152 \times \phi 102$	Lining ring $\phi 152 \times \phi 102$	180.017.527	4
5	Corpo	Torque limiter support	141.027.107	1
6	Disco intermedio	Inner plate	180.017.105	2
7	Disco sagomato	Intermediate plate	180.017.104	1
8	Disco stringifrizione	Pressure plate	180.017.114.1	1
9	Molla $\phi 6$	Spring $\phi 6$	180.014.022	8
10	Seeger	Circlip	190.000.183	2
11	Anello di rasamento	Retaining washer ring	180.014.135	2
12	Molla a balestra	Leaf spring	180.014.137	3
13	Linguetta	Ratchet	151.014.136	3
14	Mozzo R14	Hub R14	151.014.200	1
	Mozzo R15	Hub R15	151.018.121	1
15	Ponte di blocco	Clamp lock	151.014.201	2
16	Vite M14x1,5x100 + dado	Bolt M14x1,5x100+nut	165.000.622	2
17	Kit RF	Kit RF	165.000.741	1
18	Kit ponti di blocco 1 3/4"	Clamp lock set 1 3/4"	165.000.692	1

* Quantità presente nel dispositivo
 Quantity in the Safety Device

FRIZIONE CHIUSA CON RUOTA LIBERA CLOSED DISC CLUTCH TORQUE LIMITER WITH OVERRUNNING CLUTCH

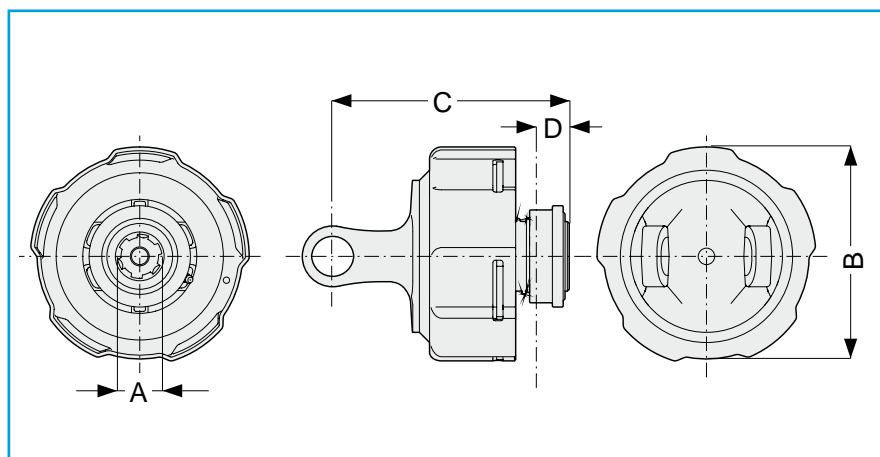

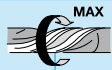
Type	Ref.	A	B		C		D				Code
			[mm]	[inch]	[mm]	[inch]	[mm]	[inch]	[Nm]	[in.lb]	
20	RW2	1 3/8" z6	ø173	6 13/16"	149	5 7/8"	26	1 1/32"	600	5300	148.422.001.1
	RW3	1 3/8" z21	ø173	6 13/16"	149	5 7/8"	26	1 1/32"	600	5300	148.422.002.1
40	RW2	1 3/8" z6	ø173	6 13/16"	161	6 3/8"	26	1 1/32"	600	5300	148.442.001.1
	RW3	1 3/8" z21	ø173	6 13/16"	161	6 3/8"	26	1 1/32"	600	5300	148.442.002.1
	RW2	1 3/8" z6	ø173	6 13/16"	161	6 3/8"	26	1 1/32"	750	6630	148.442.003.1
	RW3	1 3/8" z21	ø173	6 13/16"	161	6 3/8"	26	1 1/32"	750	6630	148.442.004.1
	RW2	1 3/8" z6	ø173	6 13/16"	161	6 3/8"	26	1 1/32"	900	7950	148.442.005.1
	RW3	1 3/8" z21	ø173	6 13/16"	161	6 3/8"	26	1 1/32"	900	7950	148.442.006.1
50	RW2	1 3/8" z6	ø173	6 13/16"	179.5	7 3/32"	26	1 1/32"	900	7950	148.452.001.1
	RW3	1 3/8" z21	ø173	6 13/16"	179.5	7 3/32"	26	1 1/32"	900	7950	148.452.002.1
	RW6	1 3/8" z6	ø173	6 13/16"	179.5	7 3/32"	26	1 1/32"	1200	10600	148.454.001.1
	RW7	1 3/8" z21	ø173	6 13/16"	179.5	7 3/32"	26	1 1/32"	1200	10600	148.454.002.1
60	RW2	1 3/8" z6	ø173	6 13/16"	186.5	7 23/64"	26	1 1/32"	900	7950	148.462.001.1
	RW3	1 3/8" z21	ø173	6 13/16"	186.5	7 23/64"	26	1 1/32"	900	7950	148.462.002.1
	RW6	1 3/8" z6	ø173	6 13/16"	186.5	7 23/64"	26	1 1/32"	1200	10600	148.464.002.1
	RW7	1 3/8" z21	ø173	6 13/16"	186.5	7 23/64"	26	1 1/32"	1200	10600	148.464.005.1
	RW6	1 3/8" z6	ø173	6 13/16"	186.5	7 23/64"	26	1 1/32"	1500	13250	148.464.001.1
	RW7	1 3/8" z21	ø173	6 13/16"	186.5	7 23/64"	26	1 1/32"	1500	13250	148.464.004.1
80	RW6	1 3/8" z6	ø173	6 13/16"	189.5	7 31/64"	26	1 1/32"	1200	10600	148.484.001.1
	RW7	1 3/8" z21	ø173	6 13/16"	189.5	7 31/64"	26	1 1/32"	1200	10600	148.484.002.1
	RW6	1 3/8" z6	ø173	6 13/16"	189.5	7 31/64"	26	1 1/32"	1500	13250	148.484.003.1
	RW7	1 3/8" z21	ø173	6 13/16"	189.5	7 31/64"	26	1 1/32"	1500	13250	148.484.004.1
	RW6	1 3/8" z6	ø173	6 13/16"	189.5	7 31/64"	26	1 1/32"	1800	15900	148.484.005.1
	RW7	1 3/8" z21	ø173	6 13/16"	189.5	7 31/64"	26	1 1/32"	1800	15900	148.484.006.1

Dispositivi di sicurezza integrali
Integral Safety Devices

NOTA: fornibile a richiesta per senso di rotazione antiorario
NOTE: available upon request for anti-clockwise direction of rotation

FRIZIONE CHIUSA CON RUOTA LIBERA CLOSED DISC CLUTCH TORQUE LIMITER WITH OVERRUNNING CLUTCH



Il dispositivo comprende un limitatore di coppia a dischi d'attrito (frizione) e una ruota libera integrati. La funzionalità assomma quelle dei singoli dispositivi con il vantaggio di risparmiare spazio e di consentire il montaggio sullo stesso lato del cardano. Il dispositivo è utile come organo di sicurezza contro picchi di carico e in macchine con grosse masse rotanti, sia durante l'avviamento che durante l'arresto, evitando inutili sollecitazioni della PTO del trattore. Questo tipo di frizione risulta avere la taratura non modificabile ed inoltre l'utilizzo di speciali molle a tazza in luogo delle più comuni molle elicoidali rende costante la taratura nonostante il progressivo consumo dei dischi d'attrito.

The device includes a disc clutch torque limiter and an incorporated overrunning clutch. The device combines the functions of the single devices thus reducing space and allowing it to be mounted on the same side of the cardan. It is useful as a safety device to protect against load peaks and in implements with large rotating mass during start-up and stopping operations, thus avoiding unnecessary stress on the tractor PTO. The torque setting of this clutch is not adjustable and the use of special Belleville springs instead of the helical springs ensures a stable torque setting compensating for the natural wear of the friction linings.

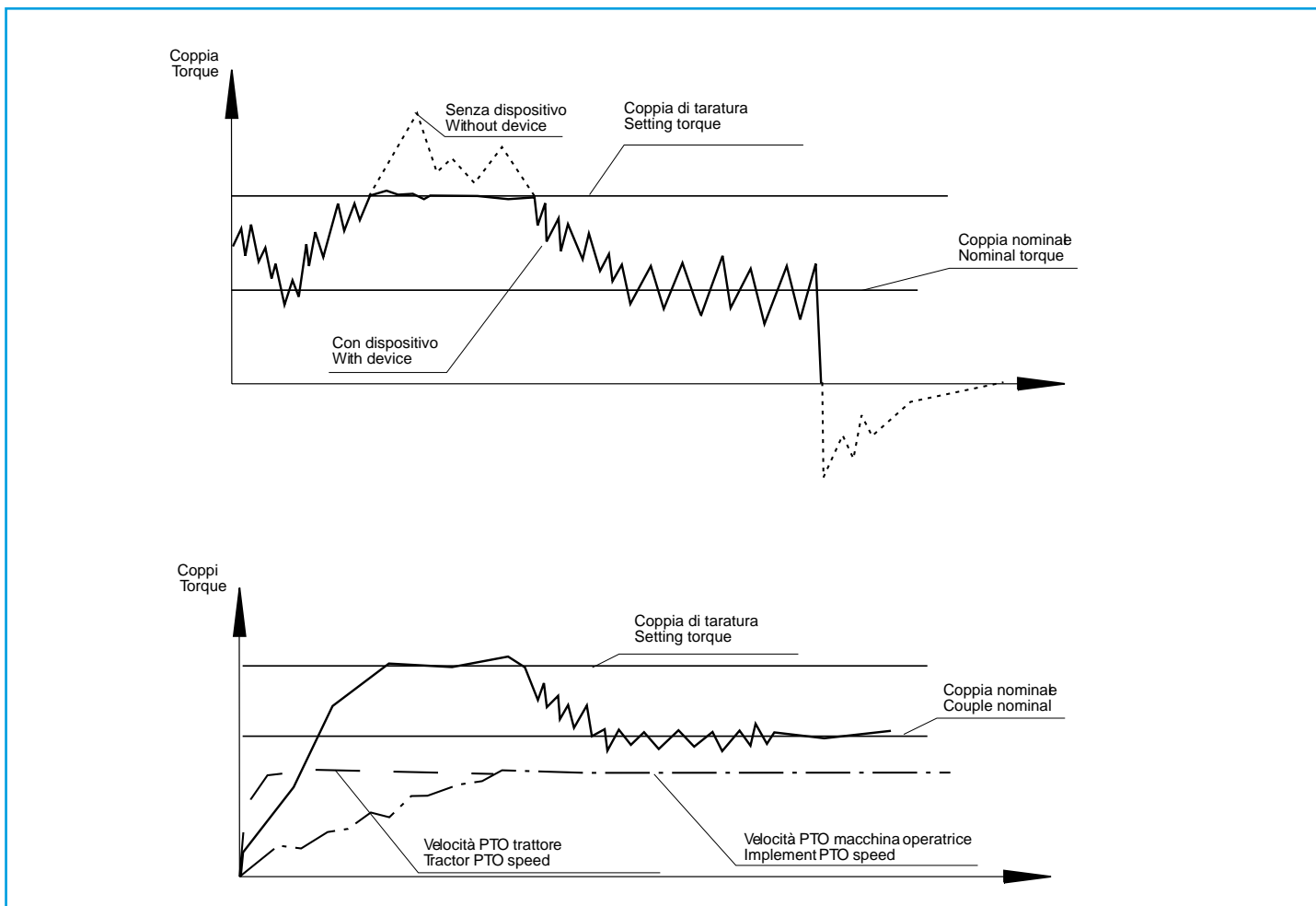

Le frizioni possono raggiungere elevate temperature.

Non toccare!

Per evitare rischi di incendio, mantenere la zona adiacente la frizione pulita da materiale infiammabile ed evitare slittamenti prolungati.

Friction clutches may become hot during use.

Do not touch!

Keep the area around the friction clutch clear of any material which could catch fire and avoid prolonged slipping.



RW2/RW3

RW

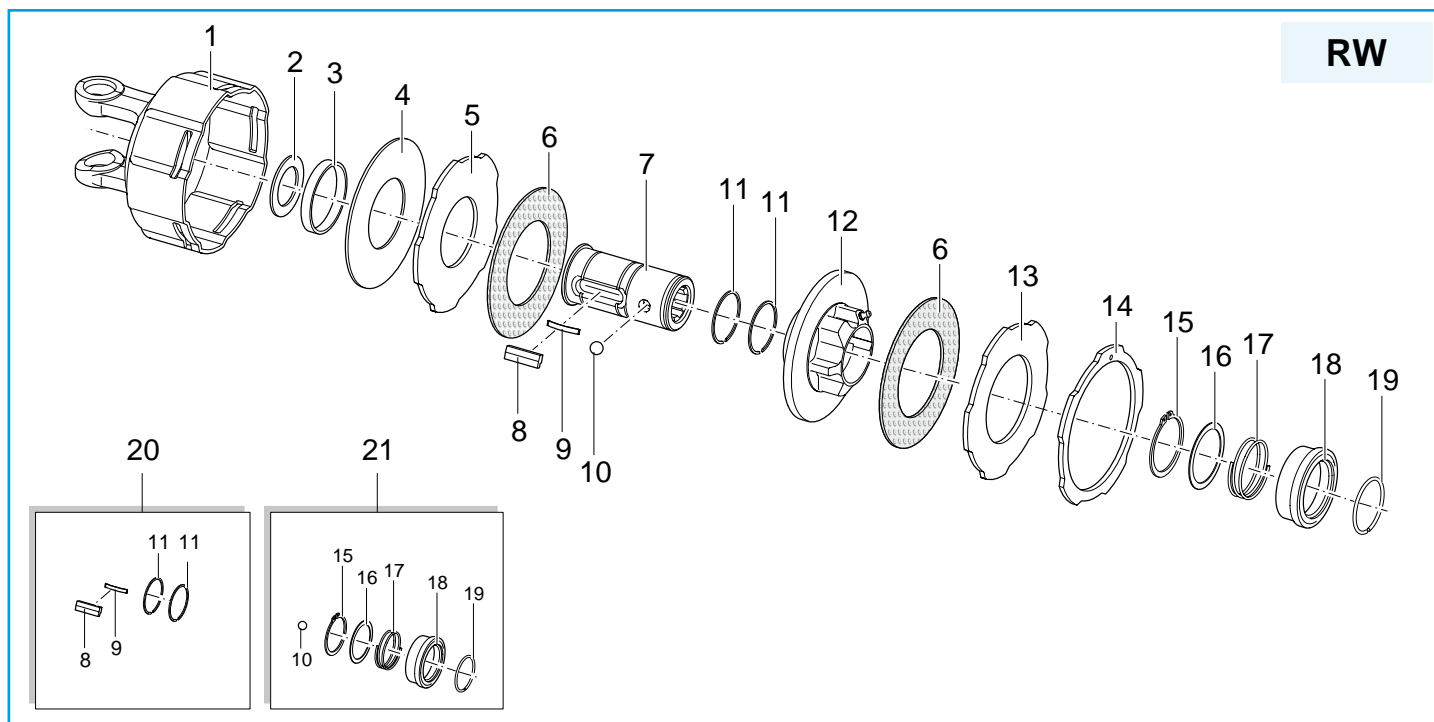

Pos.	Description		Code	Qty *
1	Forcella corpo (tipo 20)	Yoke support (type 20)	141.022.415.1	1
	Forcella corpo (tipo 40)	Yoke support (type 40)	141.024.591.1	1
	Forcella corpo (tipo 50)	Yoke support (type 50)	141.025.403.1	1
	Forcella corpo (tipo 60)	Yoke support (type 60)	141.026.725.1	1
2	Distanziale	Retaining washer	10.285.7525.00	1
3	Bronzina RW	Bush RW	180.013.429	1
4	Molla a tazza (600Nm)	Belleville spring (600 Nm)	190.000.594	1
	Molla a tazza (750Nm)	Belleville spring (750 Nm)	190.000.594	1
	Molla a tazza (900Nm)	Belleville spring (900 Nm)	190.000.607	1
5	Disco stringifrizione(600Nm)	Pressure plate W (600 Nm)	180.013.434	1
	Disco stringifrizione(750Nm)	Pressure plate W (750 Nm)	180.013.433	1
	Disco stringifrizione(900Nm)	Pressure plate W (900 Nm)	180.013.440	1
6	Dischi attrito ø152xø90	Lining ring ø152xø90	180.019.018	2
7	Mozzo RW2 - RW6	Hub RW2 - RW6	151.013.430	1
	Mozzo RW3 - RW7	Hub RW3 - RW7	151.013.457	1
8	Linguetta	Ratchet	151.014.136	2
9	Molla a balestra	Leaf spring	180.014.137	2
10	Sfere 1/2"	Ball 1/2"	190.000.078	3
11	Anello elastico SW52	Snap ring SW52	190.000.702	2
12	Corpo RW	Body RW	141.023.431	1
13	Disco di reazione	Reaction ring	180.017.269	1
14	Disco di arresto	Stop ring	180.017.276	1
15	Seeger UNI 7435-55	Seeger UNI 7435-55	190.000.488	1
16	Distanziale	Retaining washer	180.015.143	1
17	Molla collar	Collar spring	180.016.487	1
18	Manicotto scorrevole	Sliding sleeve collar	151.016.486	1
19	Seeger UNI 7433-A-55	Seeger UNI 7433-A-55	190.000.451	1
20	Kit RW	Kit RW	165.000.769	1
21	Kit collar RW	Kit collar RW	165.000.768	1

* Quantità presente nel dispositivo
 Quantity in the Safety Device



RW6/RW7

RW

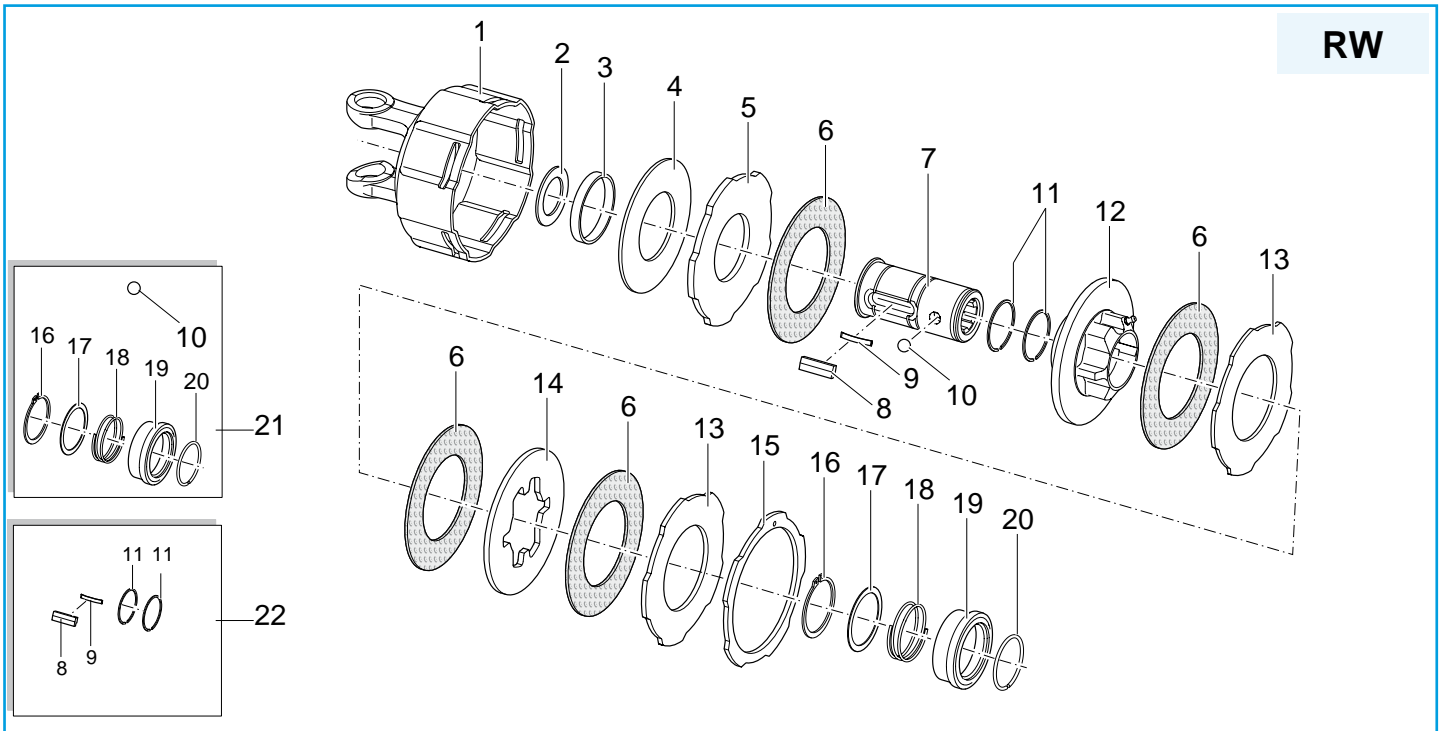

Pos.	Description		Code	Qty *
1	Forcella corpo (tipo 50)	Yoke support (type 50)	141.025.394.1	1
	Forcella corpo (tipo 60)	Yoke support (type 60)	141.026.664.1	1
	Forcella corpo (tipo 80)	Yoke support (type 80)	141.028.515.1	1
2	Distanziale	Retaining washer	10.285.7525.00	1
3	Bronzina RW	Bush RW	180.013.429	1
4	Molla a tazza (1200 Nm)	Belleville spring (1200 Nm)	190.000.594	1
	Molla a tazza (1500 Nm)	Belleville spring (1500 Nm)	190.000.594	1
	Molla a tazza (1800 Nm)	Belleville spring (1800 Nm)	190.000.607	1
5	Disco stringifrizione (1200 Nm)	Pressure plate W (1200 Nm)	180.013.434	1
	Disco stringifrizione (1500 Nm)	Pressure plate W (1500 Nm)	180.013.433	1
	Disco stringifrizione (1800 Nm)	Pressure plate W (1800 Nm)	180.013.440	1
6	Disco attrito ø152xø90	Lining ring ø152xø90	180.019.018	4
7	Mozzo RW2-RW6	Hub RW2-RW6	151.013.430	1
	Mozzo RW3-RW7	Hub RW3-RW7	151.013.457	1
8	Linguetta	Ratchet	151.014.136	2
9	Molla a balestra	Leaf spring	180.014.137	2
10	Sfere 1/2"	Ball 1/2"	190.000.078	3
11	Anello elastico SW52	Snap ring SW52	190.000.702	2
12	Corpo RW	Body RW	141.023.431	1
13	Disco intermedio	Inner plate	180.017.269	2
14	Disco sagomato	Intermediate plate	180.019.115	1
15	Disco d' arresto	Stop ring	180.017.276	1
16	Seeger UNI 7435-55	Seeger UNI 7433-A-55	190.000.488	1
17	Distanziale	Retaining washer	180.015.143	1
18	Molla collar	Collar spring	180.016.487	1
19	Manicotto collar	Sliding sleeve collar	151.016.486	1
20	Seeger UNI 7435-55	Seeger UNI 7433-A-55	190.000.451	1
21	Kit collar RW	Kit collar RW	165.000.768	1
22	Kit RW	Kit RW	165.000.769	1

* Quantità presente nel dispositivo
 Quantity in the Safety Device

DISPOSITIVI CON ALBERO MASCHIO DEVICES WITH MALE SHAFT



Ref.	A	B*	L		MAX		Code
			[mm]	[inch]	[Nm]	[in.lb]	
FM02	1 3/8" z6	1 3/8" z6	183	7 13/64"	650	5700	146.231.003.1
FM12	1 3/8" z6	1 3/8" z6	183	7 13/64"	900	7950	146.241.006.1
FM22	1 3/8" z6	1 3/8" z6	190	7 31/64"	1200	10600	146.252.009.1
FM42	1 3/8" z6	1 3/8" z6	203	7 63/64"	2000	17700	146.264.015.1

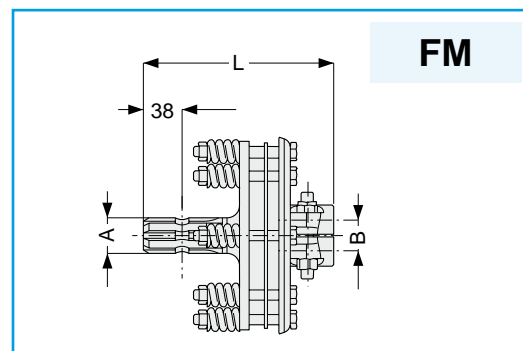

* Fornibile a richiesta con altri tipi di caletto
Can be supplied upon request with other types of splined

Ref.	A	B*	L		MAX		Code
			[mm]	[inch]	[Nm]	[in.lb]	
MM14	1 3/8" z6	1 3/8" z6	168	6 39/64"	300	2650	144.206.011.1
MM24	1 3/8" z6	1 3/8" z6	188	7 13/32"	600	5300	144.206.012.1
MM34	1 3/8" z6	1 3/8" z6	208	8 3/16"	900	7950	144.206.007.1
MM44	1 3/8" z6	1 3/8" z6	228	8 31/32"	1200	10600	144.206.013.1

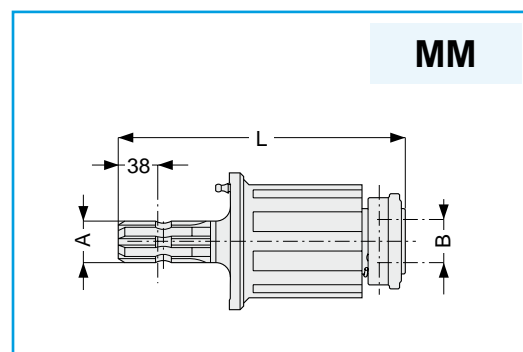

* Fornibile a richiesta con altri tipi di caletto
Can be supplied upon request with other types of splined

Ref.	A	B*	L		MAX		Code
			[mm]	[inch]	[Nm]	[in.lb]	
RM12	1 3/8" z6	1 3/8" z6	208	8 3/16"	3800	33630	145.215.015.1

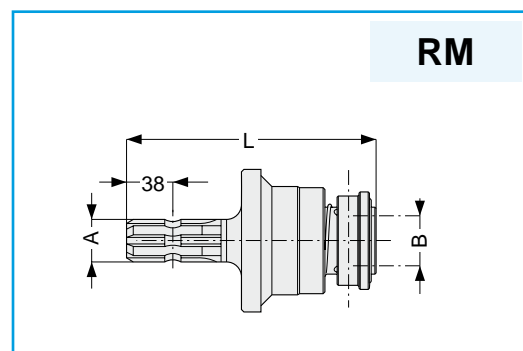

* Fornibile a richiesta con altri tipi di caletto
Can be supplied upon request with other types of splined





Questa pagina è lasciata intenzionalmente bianca
This page is intentionally left blank

DISPOSITIVI DI SICUREZZA FLANGIATI

MODULAR SAFETY DEVICES

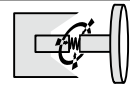
			p.
	PROGRAMMA DI PRODUZIONE PRODUCTION PROGRAM		98
BF	LIMITATORE A BULLONE DI TRANCIO SHEAR BOLT TORQUE LIMITER		100
	Caratteristiche	<i>Features</i>	100
	Parti di ricambio	<i>Spare Parts</i>	101
L	LIMITATORE AUTOMATICO AUOMATIC TORQUE LIMITER		102
	Caratteristiche	<i>Features</i>	102
	Parti di ricambio	<i>Spare Parts</i>	103
	Identificazione prodotto	<i>Product Identification</i>	103
WF	FRIZIONE CHIUSA A DISCHI MULTIPLI CLOSED DISC CLUTCH TORQUE LIMITER		104
	Caratteristiche	<i>Features</i>	104
	Parti di ricambio	<i>Spare Parts</i>	106
JF	FRIZIONE SEMIAPERTA A DISCHI MULTIPLI HALF OPENED DISC CLUTCH TORQUE LIMITER		109
	Caratteristiche	<i>Features</i>	109
	Parti di ricambio	<i>Spare Parts</i>	111
RJF	FRIZIONE SEMIAPERTA CON RUOTA LIBERA HALF OPENED DISC CLUTHC TORQUE LIMITER WITH OVERRUNNING CLUTCH		112
	Caratteristiche	<i>Features</i>	112
	Parti di ricambio	<i>Spare Parts</i>	114
LRF	LIMITATORE AUTOMATICO CON RUOTA LIBERA AUTOMATIC TORQUE LIMITER WITH OVERRUNNING CLUTCH		116
	Caratteristiche	<i>Features</i>	116
	Parti di ricambio	<i>Spare Parts</i>	117
	Identificazione prodotto	<i>Product Identification</i>	118

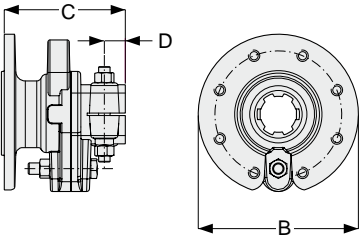
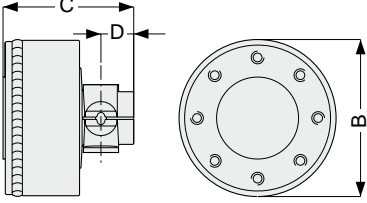
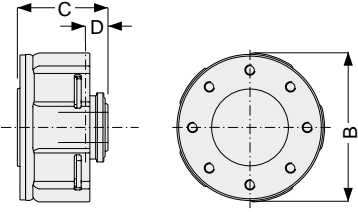
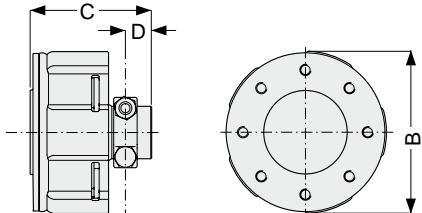
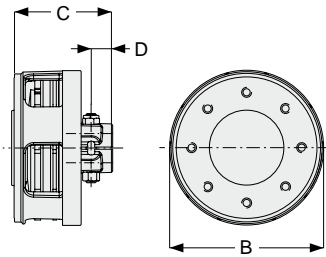

		Type	Ref.			P.						
BF 	60	80	B32F	mm	B 168	C 127	D 22	Nm 2500	in. lb. 22100	100		
			B33F	inch	6 39/64"	5"	7/8"					
			B34F B35F	mm inch	168 6 39/64"	127 5"	22 7/8"	2500 22100				
	90	B32F	mm	B 168	C 127	D 22	Nm 3500	in. lb. 30900				
		B33F	inch	6 39/64"	5"	7/8"						
		B34F B35F	mm inch	168 6 39/64"	127 5"	22 7/8"	3500 30900					
	120	B32F	mm	B 168	C 127	D 22	Nm 4000	in. lb. 35400				
		B33F	inch	6 39/64"	5"	7/8"						
		B34F B35F	mm inch	168 6 39/64"	127 5"	22 7/8"	4000 35400					
				B34F B35F	mm inch	168 6 39/64"	127 5"	22 7/8"	Nm 5000		in. lb. 44255	
	L 	60	80	L82-L83	mm	B 168	C 141	D 36	Nm 2500		in. lb. 22130	102
				L84-L85	inch	3 39/64"	5 35/64"	1 27/64"				
90		L82-L83	mm	B 168	C 141	D 36	Nm 3500	in. lb. 30900				
		L84-L85	inch	3 39/64"	5 35/64"	1 27/64"						
120		L82-L83	mm	B 168	C 141	D 36	Nm 4000	in. lb. 35400				
		L84-L85	inch	3 39/64"	5 35/64"	1 27/64"						
WF W22F-W23F-W42F-W43F 	60	80	W22F	mm	B 173	C 87	D 26	Nm 900	in. lb. 7950	104		
			W23F	inch	6 13/16"	3 27/64"	1 1/32"					
			W42F	mm	173	102	26	1100	9700			
			W43F	inch	6 13/16"	4 1/64"	1 1/32"					
	80	W42F	mm	173	102	26	Nm 1500	in. lb. 13250				
		W43F	inch	6 13/16"	4 1/64"	1 1/32"						
		W42F	mm	173	102	26	Nm 1800	in. lb. 15900				
		W43F	inch	6 13/16"	4 1/64"	1 1/32"						
WF W44F-W45F 	60	80	W44F	mm	B 173	C 125	D 28	Nm 1100	in. lb. 9700	104		
			W45F	inch	6 13/16"	4 59/64"	1 7/64"					
	80	W44F	mm	173	125	28	Nm 1500	in. lb. 13250				
		W45F	inch	6 13/16"	4 59/64"	1 7/64"						
	120	W44F	mm	173	125	28	Nm 1800	in. lb. 15900				
		W45F	inch	6 13/16"	4 59/64"	1 7/64"						
JF 	60	80	J42F	mm	B 186	C 120	D 26	Nm 1600	in. lb. 7950	109		
			J43F	inch	7 21/64"	3 27/64"	1 1/32"					
			J44F	mm	186	120	26	1600	7950			
	90	J45F	inch	7 21/64"	3 27/64"	1 1/32"						
		J42F	mm	186	120	26	Nm 2000	in. lb. 17700				
		J43F	inch	7 21/64"	3 27/64"	1 1/32"						
	120	J44F	mm	186	120	26	Nm 2000	in. lb. 17700				
		J45F	inch	7 21/64"	3 27/64"	1 1/32"						
		J42F	mm	186	120	26	Nm 2400	in. lb. 21200				
	120	J43F	inch	7 21/64"	3 27/64"	1 1/32"						
		J44F	mm	186	120	26	Nm 2400	in. lb. 21200				
		J45F	inch	7 21/64"	3 27/64"	1 1/32"						
			J44F	mm	186	120	26	Nm 3300	in. lb. 29000			
			J45F	inch	7 21/64"	3 27/64"	1 1/32"					

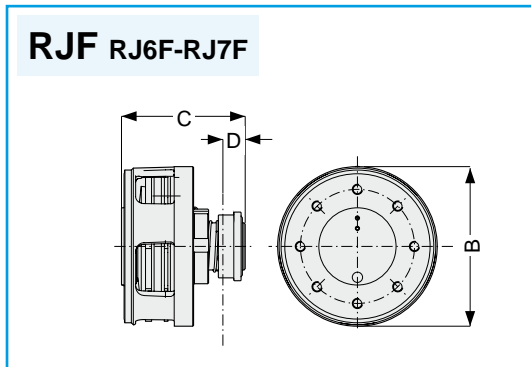
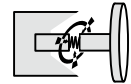

Type	Ref.						
60 80 90 120	RJ6F	mm	B	C	D	Nm	in. lb.
	RJ7F	inch	186	141	26	1600	7950
	RJ6F	mm	7 21/64"	5 35/64"	1 1/32"	2000	17700
	RJ7F	inch	186	141	26	2400	21200
	RJ6F	mm	7 21/64"	5 35/64"	1 1/32"		
	RJ7F	inch	186	141	26		

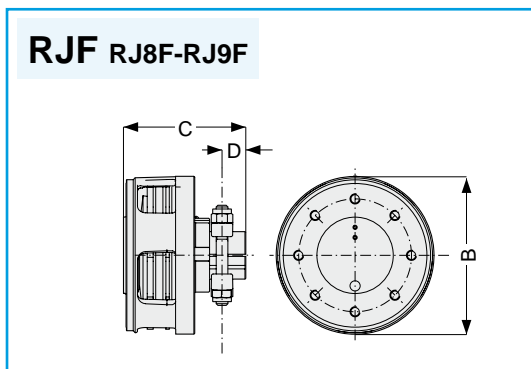

60 80 90 120	RJ8F	mm	B	C	D	Nm	in. lb.
	RJ9F	inch	186	141	28	1600	7950
	RJ8F	mm	7 21/64"	5 35/64"	1 7/64"	2000	17700
	RJ9F	inch	186	141	28	2400	21200
	RJ8F	mm	7 21/64"	5 35/64"	1 7/64"	3300	29000
	RJ9F	inch	186	141	28		

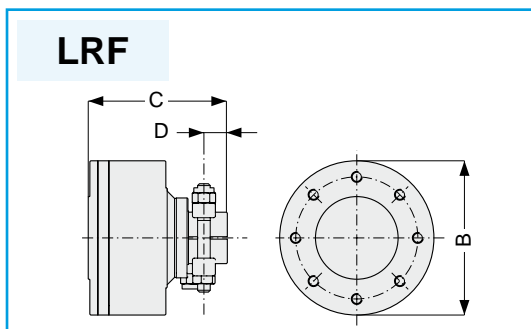

60 80 90 120	LR2F	mm	B	C	D	Nm	in. lb.
	LR3F	inch	168	149	28	2500	22100
	LR4F	mm	6 39/64"	5 7/8"	1 7/64"	2500	22100
	LR5F	inch	168	149	28	3000	26500
	LR2F	mm	6 39/64"	5 7/8"	1 7/64"	3500	30900
	LR3F	inch	168	149	28		

LIMITATORE A BULLONE DI TRANCIO SHEAR BOLT TORQUE LIMITER

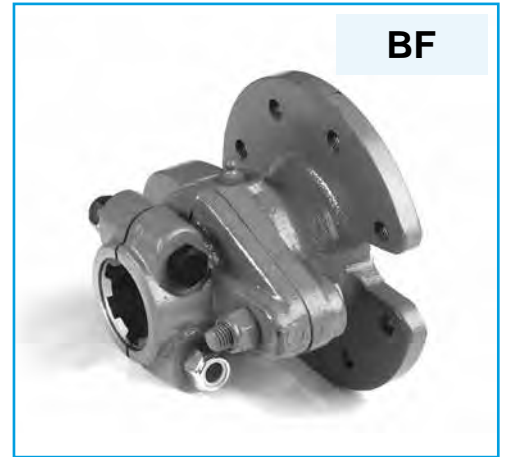
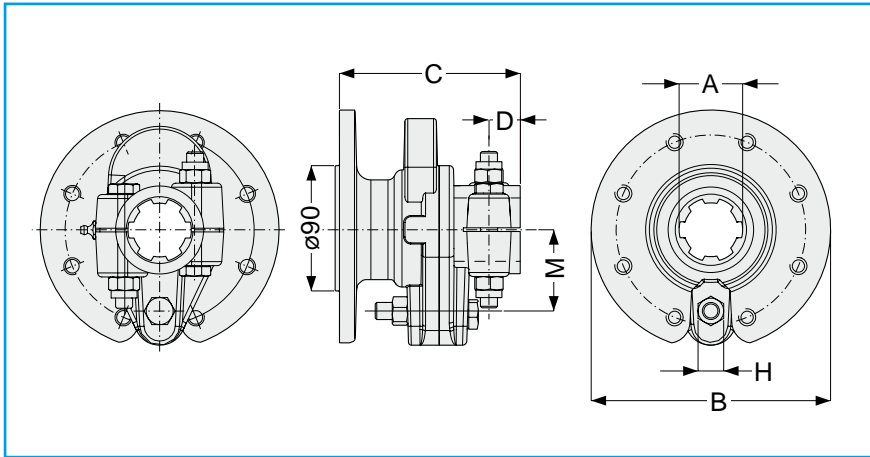
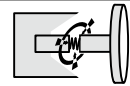

Type	Ref.	A		B		C		D		M		MAX [Nm] [in.lb]	H ISO 8.8	Code	
		[mm]	[inch]	[mm]	[inch]	[mm]	[inch]	[mm]	[inch]	[mm]	[inch]				
60	B32F	1 3/8"	z6	168	6 39/64"	127	5"	22	7/8"	55	2 11/64"	2500	22100	M10x60	143.200.001.1
	B33F	1 3/8"	z21	168	6 39/64"	127	5"	22	7/8"	55	2 11/64"	2500	22100	M10x60	143.200.002.1
	B34F	1 3/4"	z6	168	6 39/64"	127	5"	22	7/8"	55	2 11/64"	2500	22100	M10x60	143.200.007.1
	B35F	1 3/4"	z20	168	6 39/64"	127	5"	22	7/8"	55	2 11/64"	2500	22100	M10x60	143.200.003.1
80	B32F	1 3/8"	z6	168	6 39/64"	127	5"	22	7/8"	57	2 15/64"	3500	30900	M12x65	143.200.006.1
	B33F	1 3/8"	z21	168	6 39/64"	127	5"	22	7/8"	57	2 15/64"	3500	30900	M12x65	143.200.004.1
	B34F	1 3/4"	z6	168	6 39/64"	127	5"	22	7/8"	57	2 15/64"	3500	30900	M12x65	143.200.005.1
	B35F	1 3/4"	z20	168	6 39/64"	127	5"	22	7/8"	57	2 15/64"	3500	30900	M12x65	143.200.010.1
90	B32F	1 3/8"	z6	168	6 39/64"	127	5"	22	7/8"	65	2 9/16"	4000	35400	M12x65	143.200.011.1
	B33F	1 3/8"	z21	168	6 39/64"	127	5"	22	7/8"	65	2 9/16"	4000	35400	M12x65	143.200.012.1
	B34F	1 3/4"	z6	168	6 39/64"	127	5"	22	7/8"	65	2 9/16"	4000	35400	M12x65	143.200.013.1
	B35F	1 3/4"	z20	168	6 39/64"	127	5"	22	7/8"	65	2 9/16"	4000	35400	M12x65	143.200.014.1
	B34F	1 3/4"	z6	168	6 39/64"	127	5"	22	7/8"	65	2 9/16"	5000	44260	M14x70	143.200.008.1
120	B35F	1 3/4"	z20	168	6 39/64"	127	5"	22	7/8"	65	2 9/16"	5000	44260	M14x70	143.200.009.1

NOTA: sul tipo 120 caletto trattato termicamente
NOTE: for type 120 the spline is heat treated

Con tarature superiori a 4000 Nm il caletto del mozzo è trattato termicamente.
With setting value higher than 4000 Nm the hub spline is heat treated.

Il limitatore interviene interrompendo la trasmissione di potenza quando la coppia supera il limite di taratura mediante la rottura del bullone. La trasmissione viene ripristinata inserendo un nuovo bullone nel dispositivo.

The torque limiter interrupts the power transmission when the torque exceeds the setting value, by shearing the bolt. Transmission is restored by inserting a new bolt in the device.

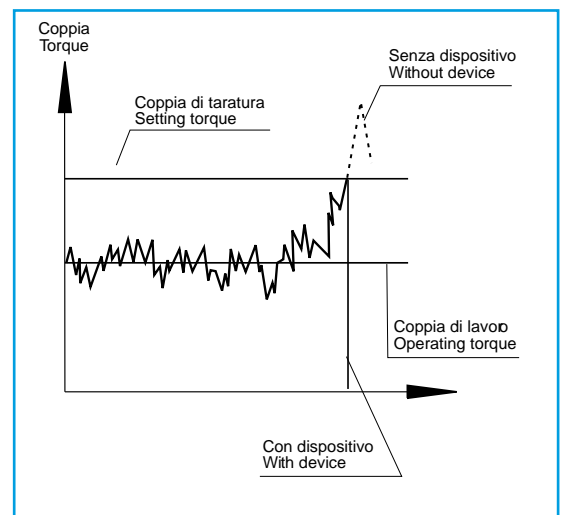

LIMITATORE A BULLONE DI TRANCIO

SHEAR BOLT TORQUE LIMITER

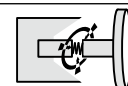

BF

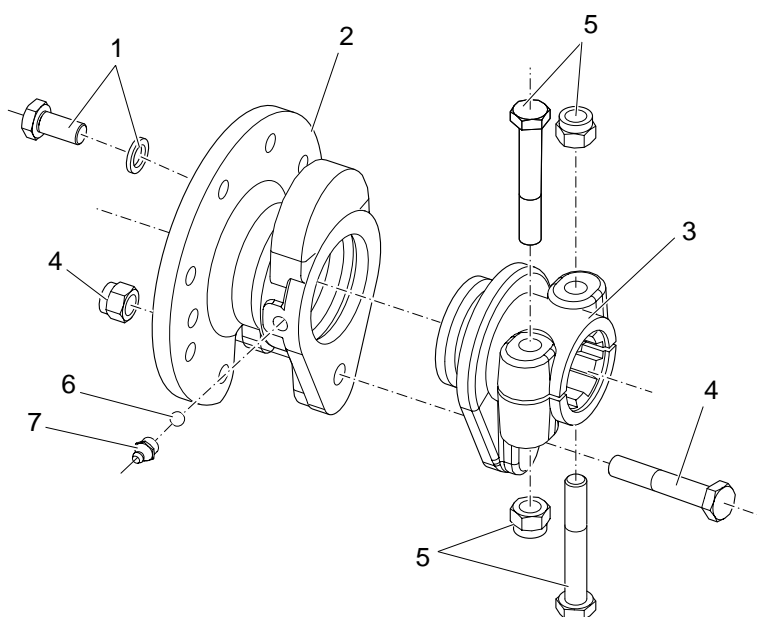

Pos.			Code	Qty *
1	Kit vite M12x1,25x65 + dado	Bolt M12x1,25x65+nut	165.000.708	8
2	Flangia BF (tipo 60)	Flange BF (type 60)	151.018.547.1	1
	Flangia BF (tipo 80)	Flange BF (type 80)	151.018.451.1	1
	Flangia BF (tipo 90)	Flange BF (type 90)	151.018.559.1	1
	Flangia BF (tipo 120)	Flange BF (type 120)	141.220.014.1	1
3	Mozzo B32 (tipo 60)	Hub B32 (type 60)	151.016.243.1	1
	Mozzo B33 (tipo 60)	Hub B33 (type 60)	151.016.724.1	1
	Mozzo B34 (tipo 60)	Hub B34 (type 60)	151.018.513.1	1
	Mozzo B35 (tipo 60)	Hub B35 (type 60)	151.018.369.1	1
	Mozzo B32 (tipo 80)	Hub B32 (type 80)	151.018.163.1	1
	Mozzo B33 (tipo 80)	Hub B33 (type 80)	151.018.560.1	1
	Mozzo B34 (tipo 80)	Hub B34 (type 80)	151.018.452.1	1
	Mozzo B35 (tipo 80)	Hub B35 (type 80)	151.018.162.1	1
	Mozzo B32 (tipo 90)	Hub B32 (type 90)	151.019.370.1	1
	Mozzo B33 (tipo 90)	Hub B33 (type 90)	151.019.371.1	1
	Mozzo B34 (tipo 90)	Hub B34 (type 90)	151.019.372.1	1
	Mozzo B35 (tipo 90)	Hub B35 (type 90)	151.019.139.1	1
4	Mozzo B34 (tipo 120)	Hub B34 (type 120)	151.120.015.1	1
	Mozzo B35 (tipo 120)	Hub B35 (type 120)	151.120.016.1	1
	Kit vite M10x60 + dado	Bolt M10x60+nut	165.000.507	1
	Kit vite M12x65 + dado	Bolt M12x65+nut	165.000.512	1
5	Kit vite M14x65 + dado	Bolt M14x65+nut	165.000.765	1
	Kit vite M12x1.25x75 + dado	Bolt M12x1.25x75+nut	165.000.598	2
6	Kit vite M16x2x80 + dado	Bolt M16x2x80+nut	165.000.576	2
	Sfera 5/16"	Ball 5/16"	190.000.023	24
7	Ingrassatore M10x1	Greaser M10x1	190.000.021	1

Dispositivi di sicurezza flangiati
Modular Safety Devices

* Quantità presente nel dispositivo
Quantity in the Safety Device

LIMITATORE AUTOMATICO AUTOMATIC TORQUE LIMITER

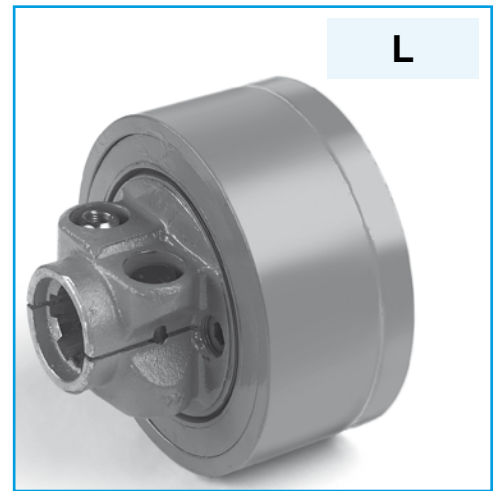
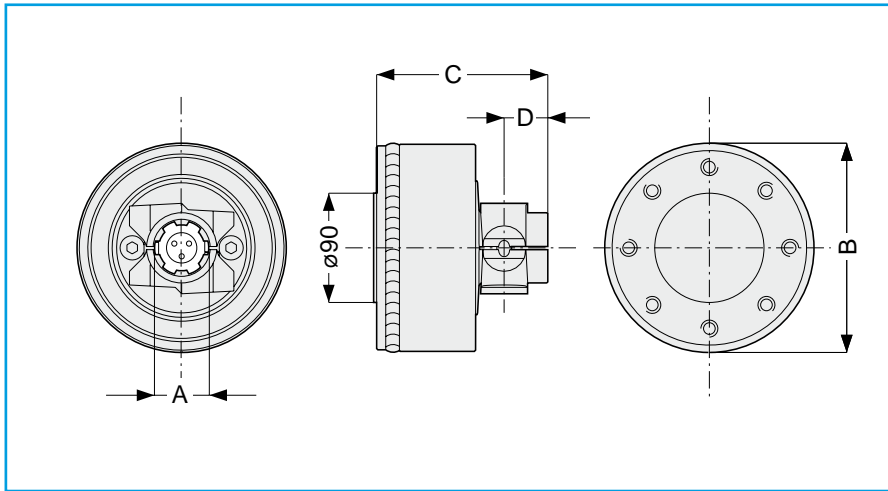
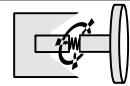

Type	Ref.	A		B		C		D		MAX		Code		
		[mm]	[inch]	[mm]	[inch]	[mm]	[inch]	[mm]	[inch]	[Nm]	[in.lb]			
60	80	90	120	L82	1 3/8" z.6	168	6 39/64"	141	5 35/64"	36	1 27/64"	2500	22130	144.306.043.1
				L83	1 3/8" z.21	168	6 39/64"	141	5 35/64"	36	1 27/64"	2500	22130	144.306.054.1
				L84	1 3/4" z.6	168	6 39/64"	141	5 35/64"	36	1 27/64"	2500	22130	144.306.018.1
				L85	1 3/4" z.20	168	6 39/64"	141	5 35/64"	36	1 27/64"	2500	22130	144.306.055.1
60	80	90	120	L82	1 3/8" z.6	168	6 39/64"	141	5 35/64"	36	1 27/64"	3500	30900	144.306.048.1
				L83	1 3/8" z.21	168	6 39/64"	141	5 35/64"	36	1 27/64"	3500	30900	144.306.056.1
				L84	1 3/4" z.6	168	6 39/64"	141	5 35/64"	36	1 27/64"	3500	30900	144.306.028.1
				L85	1 3/4" z.20	168	6 39/64"	141	5 35/64"	36	1 27/64"	3500	30900	144.306.057.1
				L82	1 3/8" z.6	168	6 39/64"	141	5 35/64"	36	1 27/64"	4000	35400	144.306.058.1
60	80	90	120	L83	1 3/8" z.21	168	6 39/64"	141	5 35/64"	36	1 27/64"	4000	35400	144.306.059.1
				L84	1 3/4" z.6	168	6 39/64"	141	5 35/64"	36	1 27/64"	4000	35400	144.306.060.1
				L85	1 3/4" z.20	168	6 39/64"	141	5 35/64"	36	1 27/64"	4000	35400	144.306.042.1

A richiesta:

- senso di rotazione antiorario
- completo di molle frontali

On request:

- anti-clockwise direction of rotation
- integrated with front-side springs

Il limitatore a reinnesto automatico Comer consente di interrompere la trasmissione di potenza fra trattore e macchina operatrice quando si verifica un incremento di coppia che superi il valore di sicurezza della macchina operatrice, salvaguardando così la macchina stessa, la trasmissione e gli organi del trattore. Al raggiungimento della soglia di intervento del limitatore L, il valore di coppia trasmessa viene ridotto a valori molto bassi interrompendo la trasmissione del moto, che viene ripristinata automaticamente mediante una diminuzione del regime di rotazione della PTO del trattore e la contemporanea eliminazione della causa esterna. La particolare costruzione del dispositivo di sicurezza L garantisce un funzionamento costante e ripetibile nel tempo con un intervento di manutenzione praticamente assente.

The Comer automatic torque limiter device interrupts the power transmission between tractor and implement when an overload occurs. This way the device prevents the failures or damages on tractor, implement and PTO driveshaft. When the operating torque exceeds the setting torque, the L device cuts out the torque; then the power transmission is automatically re-established by the PTO tractor speed reduction and the removal of the external cause. The specific device allows a reliable operation with low maintenance requirements.

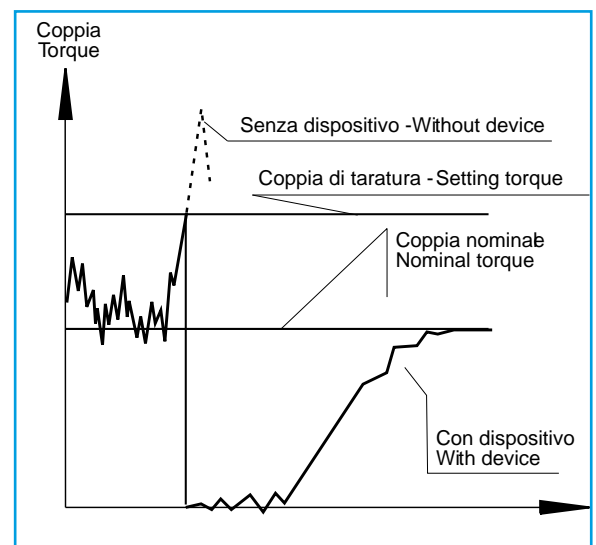

LIMITATORE AUTOMATICO AUTOMATIC TORQUE LIMITER

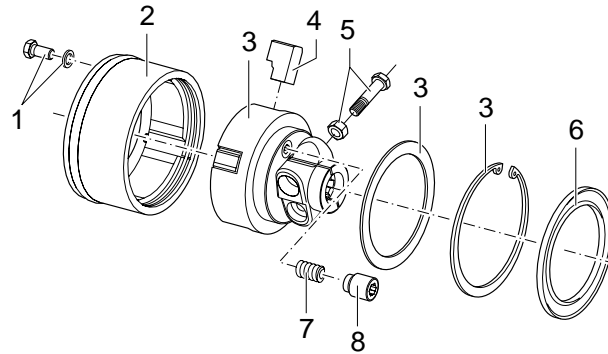

L



Pos.			Code	Qty *
1	Vite M12x1,25x25 + rondella	Bolt M12x1,25x25 + washer	165.000.708	8
2	Fondello corpo	Outer casing	141.028.411.1	1
3	Kit mozzo L82 (tipo 60)	Hub set L82 (type 60)	165.000.730	1
	Kit mozzo L83 (tipo 60)	Hub set L83 (type 60)	165.000.731	1
	Kit mozzo L84 (tipo 60)	Hub set L84 (type 60)	165.000.732	1
	Kit mozzo L85 (tipo 60)	Hub set L85 (type 60)	165.000.733	1
	Kit mozzo L82 (tipo 80)	Hub set L82 (type 80)	165.000.734	1
	Kit mozzo L83 (tipo 80)	Hub set L83 (type 80)	165.000.735	1
	Kit mozzo L84 (tipo 80)	Hub set L84 (type 80)	165.000.720	1
	Kit mozzo L85 (tipo 80)	Hub set L85 (type 80)	165.000.736	1
	Kit mozzo L82 (tipo 90)	Hub set L82 (type 90)	165.000.737	1
	Kit mozzo L83 (tipo 90)	Hub set L83 (type 90)	165.000.738	1
	Kit mozzo L84 (tipo 90)	Hub set L84 (type 90)	165.000.739	1
	Kit mozzo L85 (tipo 90)	Hub set L85 (type 90)	165.000.740	1
4	Linguetta (tipo 60)	Ratchet (type 60)	151.018.376	4
	Linguetta (tipo 80-90)	Ratchet (type 80-90)	151.018.390	4
5	Vite M12x1,25x55 + dado	Bolt M12x1,25x55+nut	165.000.752	2
6	Paragrasso	Grease protection	180.018.400	1
7	Molla frontale (tipo 60)	Front-side spring (type 60)	180.018.383	2
	Molla frontale (tipo 80-90)	Front-side spring (type 80/90)	180.018.382	2
8	Grano M20x1,5x25	Screw M20x1,5x25	190.000.478	2

* Quantità presente nel dispositivo
Quantity in the Safety Device

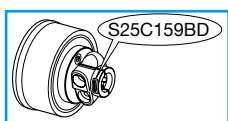
Identificazione prodotto / Product Identification

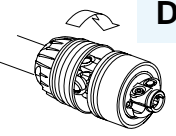
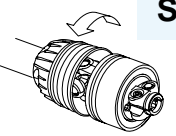

S 2 5 C 1 5 9 B D

<p>Con molle elicoidali With springs</p>  <p>M</p>	 <p>15=1500 Nm 29=2900 Nm 16=1600 Nm 30=3000 Nm 17=1700 Nm 31=3100 Nm 18=1800 Nm 32=3200 Nm 19=1900 Nm 33=3300 Nm 20=2000 Nm 34=3400 Nm 21=2100 Nm 35=3500 Nm 22=2200 Nm 36=3600 Nm 23=2300 Nm 37=3700 Nm 24=2400 Nm 38=3800 Nm 25=2500 Nm 39=3900 Nm 26=2600 Nm 40=4000 Nm 27=2700 Nm 28=2800 Nm</p>	<p>Mese di produzione Production month</p> <p>A = Gen Jan B = Feb Feb C = Mar Mar D = Apr Apr E = Mag May F = Giu Jun G = Lug Jul H = Ago Aug I = Set Sep J = Ott Oct K = Nov Nov L = Dic Dec</p>	<p>Numero progressivo del pezzo</p> <p>Parts progressive number</p> <p>N</p>	<p>Anno di produzione Production year</p> <p>A = 2019 B = 2020 C = 2021 D = 2022 E = 2023 F = 2024 G = 2025 H = 2026 I = 2027 etc.</p>	 <p>D</p>  <p>S</p>
---	--	---	--	--	---

Dispositivi di sicurezza flangiati
Modular Safety Devices

FRIZIONE CHIUSA A DISCHI MULTIPLI
CLOSED DISC CLUTCH TORQUE LIMITER

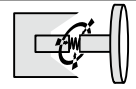

W22F - W23F - W42F - W43F

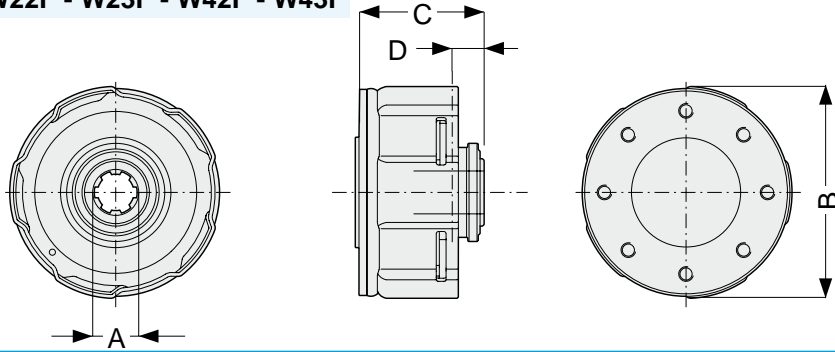

W44F - W45F

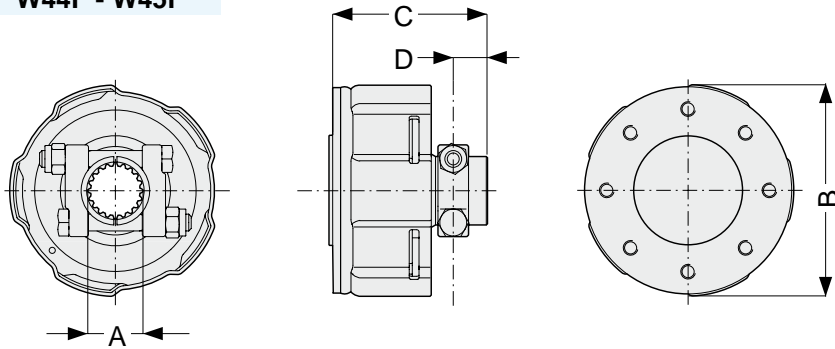

WF



Type	Ref.	A		B		C		D		MAX		Code
		[mm]	[inch]	[mm]	[inch]	[mm]	[inch]	[mm]	[inch]	[Nm]	[in.lb]	
60	W22F	1 3/8" z6	173	6 13/16"	87	3 27/64"	26	1 1/32"	900	7950	148.302.015.1	
	W23F	1 3/8" z21	173	6 13/16"	87	3 27/64"	26	1 1/32"	900	7950	148.302.016.1	
	80	W42F	1 3/8" z6	173	6 13/16"	102	4 1/64"	26	1 1/32"	1100	9700	148.304.011.1
		W43F	1 3/8" z21	173	6 13/16"	102	4 1/64"	26	1 1/32"	1100	9700	148.304.012.1
		W44F	1 3/4" z6	173	6 13/16"	125	4 59/64"	28	1 7/64"	1100	9700	148.304.018.1
		W45F	1 3/4" z20	173	6 13/16"	125	4 59/64"	28	1 7/64"	1100	9700	148.304.019.1
		W42F	1 3/8" z6	173	6 13/16"	102	4 1/64"	26	1 1/32"	1500	13250	148.304.013.1
		W43F	1 3/8" z21	173	6 13/16"	102	4 1/64"	26	1 1/32"	1500	13250	148.304.014.1
	W44F	1 3/4" z6	173	6 13/16"	125	4 59/64"	28	1 7/64"	1500	13250	148.304.020.1	
	W45F	1 3/4" z20	173	6 13/16"	125	4 59/64"	28	1 7/64"	1500	13250	148.304.021.1	
	W42F	1 3/8" z6	173	6 13/16"	102	4 1/64"	26	1 1/32"	1800	15900	148.304.015.1	
	W43F	1 3/8" z21	173	6 13/16"	102	4 1/64"	26	1 1/32"	1800	15900	148.304.016.1	
W44F	1 3/4" z6	173	6 13/16"	125	4 59/64"	28	1 7/64"	1800	15900	148.304.022.1		
W45F	1 3/4" z20	173	6 13/16"	125	4 59/64"	28	1 7/64"	1800	15900	148.304.023.1		

FRIZIONE CHIUSA A DISCHI MULTIPLI CLOSED DISC CLUTCH TORQUE LIMITER

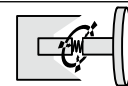

La frizione "chiusa" a dischi multipli WF interviene quando la coppia di lavoro supera la coppia di taratura. Durante la fase di limitazione del picco di coppia la frizione continua a trasmettere potenza. La frizione è utilizzabile sia come dispositivo di sicurezza contro picchi di coppia sia per avviare macchine con elevata inerzia rotazionale. Questo tipo di frizione risulta avere la taratura non modificabile ed inoltre l'utilizzo di speciali molle a tazza in luogo delle più comuni molle elicoidali rende costante la taratura nonostante il progressivo consumo dei dischi d'attrito.

The closed disc clutch torque limiter WF is activated when the setting torque exceeds the calibration torque. During the torque peak limiting phase, the clutch keeps on transmitting power. The clutch can be used both as safety device to protect against load peaks and to start machines with high rotational inertia. The torque setting of this clutch is not adjustable and the use of special Belleville springs instead of the helical springs ensures a stable torque setting compensating for the natural wear of the friction linings.

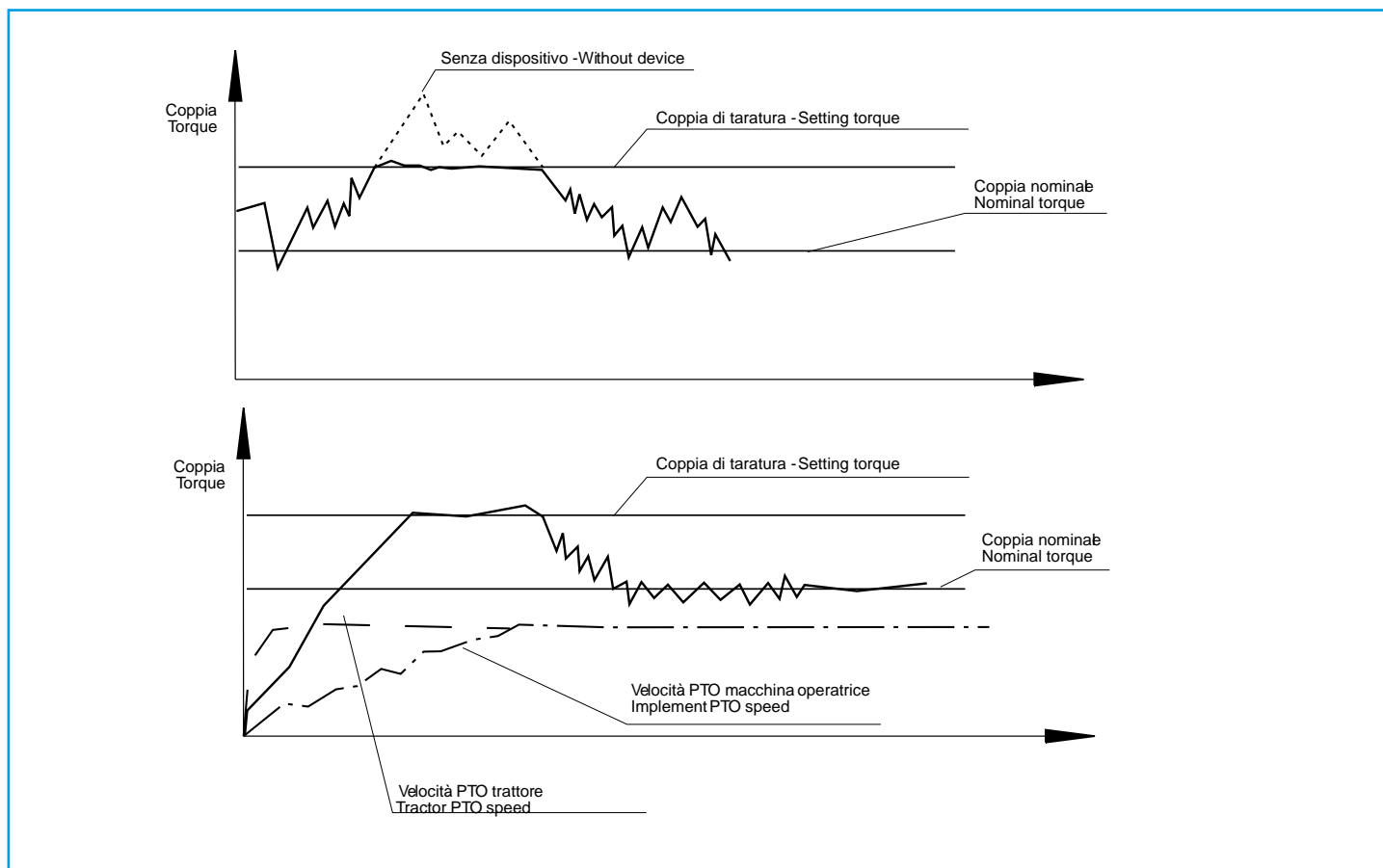

Le frizioni possono raggiungere elevate temperature.

Non toccare!

Per evitare rischi di incendio, mantenere la zona adiacente la frizione pulita da materiale infiammabile ed evitare slittamenti prolungati.

Friction clutches may become hot during use.

Do not touch!

Keep the area around the friction clutch clear of any material which could catch fire and avoid prolonged slipping.

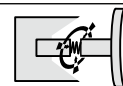

W22F / W23F

WF

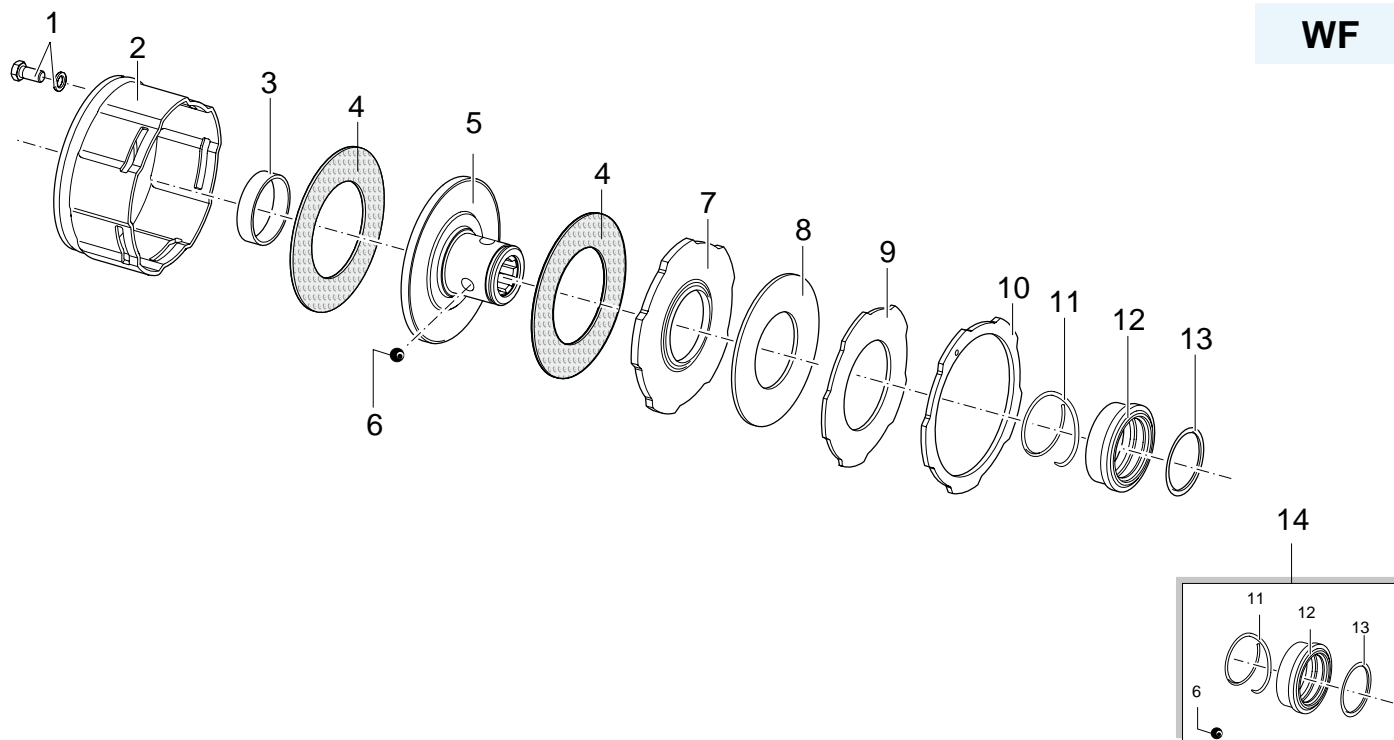

Pos.			Code	Qty *
1	Vite M12x1,25x25 + rondella	Bolt M12x1,25x25 + washer	165.000.708	8
2	Fondello corpo	Outer casing	141.027.389.1	1
3	Bronzina	Bush	180.019.019	1
4	Disco attrito ø152xø90	Lining rings ø152xø90	180.019.018	2
5	Mozzo W22	Hub W22	151.017.281	1
	Mozzo W23	Hub W23	151.017.296	1
6	Sfere 1/2"	Ball 1/2"	190.000.078	3
7	Disco stringifrizione W (600 Nm)	Pressure plate W (600 Nm)	180.017.282	1
	Disco stringifrizione W (750 Nm)	Pressure plate W (750 Nm)	180.017.270	1
	Disco stringifrizione W (900 Nm)	Pressure plate W (900 Nm)	180.017.282	1
8	Molla a tazza (600 Nm)	Belleville spring (600 Nm)	190.000.594	1
	Molla a tazza (750 Nm)	Belleville spring (750 Nm)	190.000.594	1
	Molla a tazza (900 Nm)	Belleville spring (900 Nm)	190.000.607	1
9	Disco di reazione W	Reaction ring W	180.017.269	1
10	Disco d'arresto W	Stop ring W	180.017.276	1
11	Molla collar	Collar spring	180.016.487	1
12	Manicotto collar	Sliding sleeve collar	151.016.486	1
13	Seeger	Snap ring	190.000.451	1
14	Kit collar W	Kit collar W	165.000.719	1

* Quantità presente nel dispositivo
 Quantity in the Safety Device

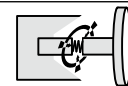

W42F / W43F

WF

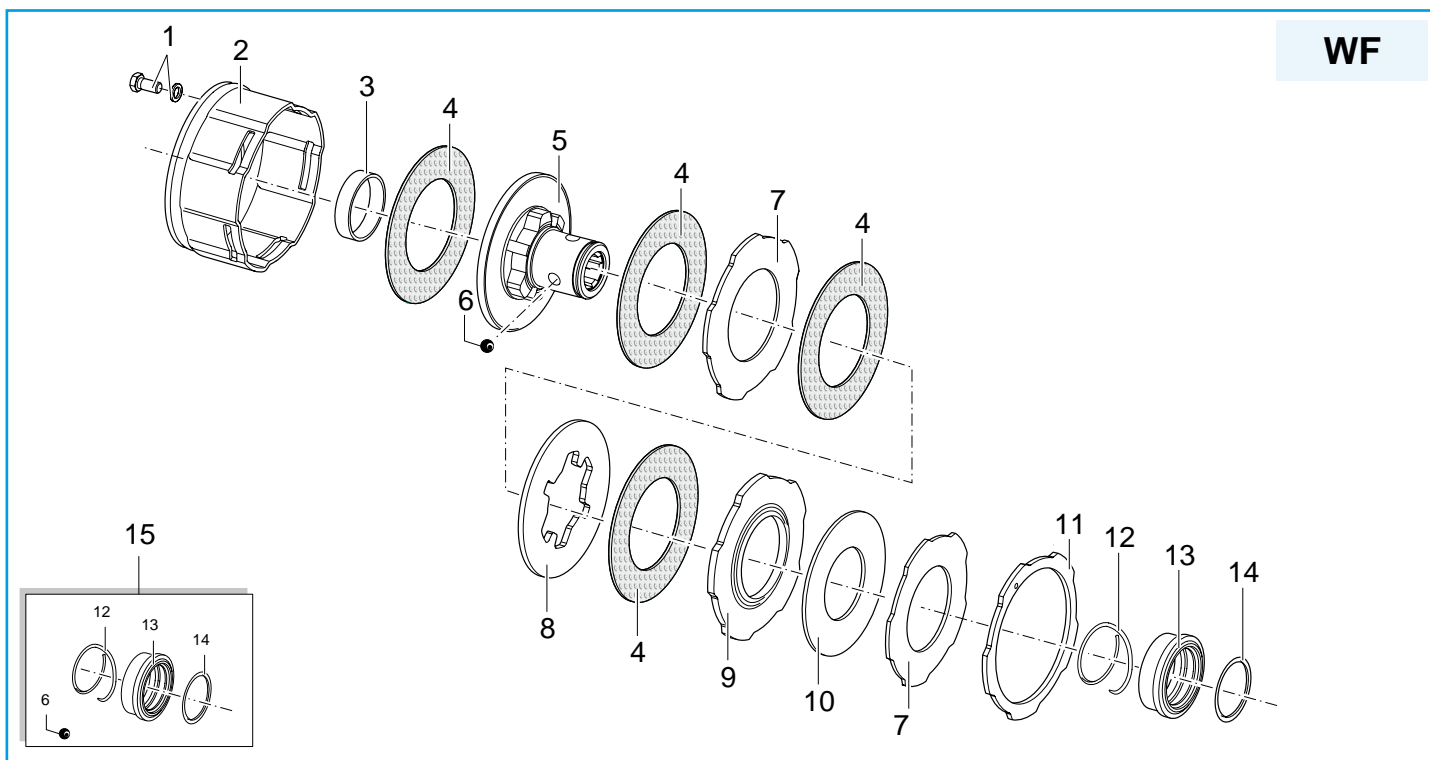

Pos.			Code	Qty *
1	Vite M12x1,25x25 + rondella	Bolt M12x1,25x25 + washer	165.000.708	8
2	Fondello corpo	Outer casing	141.027.295.1	1
3	Bronzina	Bush	180.019.019	1
4	Disco attrito $\varnothing 152 \times \varnothing 90$	Lining ring $\varnothing 152 \times \varnothing 90$	180.019.018	4
5	Mozzo W42	Hub W42	151.019.158	1
	Mozzo W43	Hub W43	151.017.297	1
6	Sfere 1/2"	Ball 1/2"	190.000.078	3
7	Disco intermedio	Inner plate	180.017.269	2
8	Disco sagomato	Intermediate plate	180.019.115	1
9	Disco stringifrizione W (1100 Nm)	Pressure plate W (1100 Nm)	180.017.282	1
	Disco stringifrizione W (1500 Nm)	Pressure plate W (1500 Nm)	180.017.282	1
	Disco stringifrizione W (1800 Nm)	Pressure plate W (1800 Nm)	180.013.451	1
10	Molla a tazza (1100 Nm)	Belleville spring (1100 Nm)	190.000.594	1
	Molla a tazza (1500 Nm)	Belleville spring (1500 Nm)	190.000.607	1
	Molla a tazza (1800 Nm)	Belleville spring (1800 Nm)	190.000.855	1
11	Disco d'arresto W	Stop ring W	180.017.276	1
12	Molla collar	Collar spring	180.016.487	1
13	Manicotto collar	Sliding sleeve collar	151.016.486	1
14	Seeger	Snap ring	190.000.451	1
15	Kit collar W	Kit collar W	165.000.719	1

* Quantità presente nel dispositivo
Quantity in the Safety Device

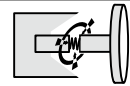

W44F / W45F

WF

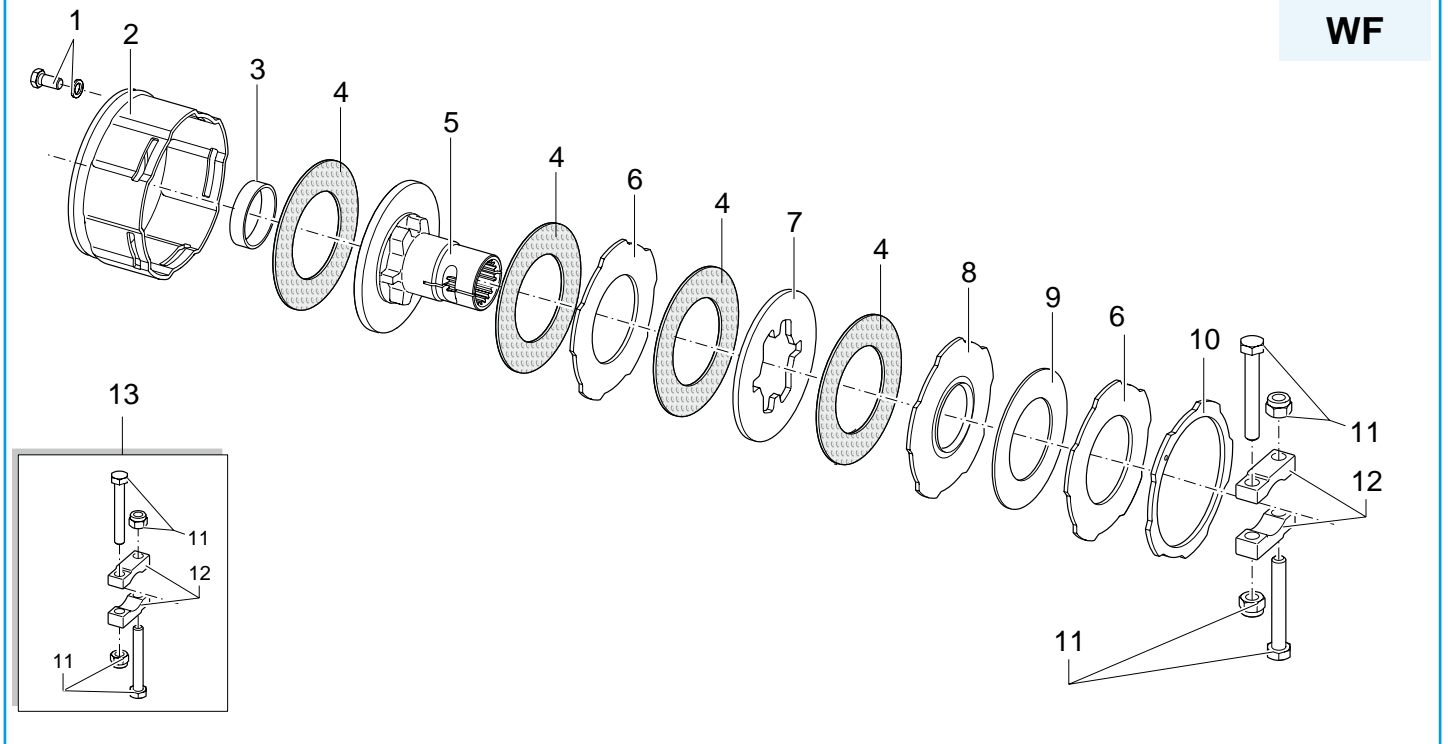

Pos.			Code	Qty *
1	Vite M12x1,25x25 + rondella	Bolt M12x1,25x25 + washer	165.000.708	8
2	Fondello corpo	Outer casing	141.027.295.1	1
3	Bronzina	Bush	180.019.019	1
4	Disco attrito $\phi 152 \times \phi 90$	Lining ring $\phi 152 \times \phi 90$	180.019.018	4
5	Mozzo W44	Hub W42	151.017.390	1
	Mozzo W45	Hub W43	151.017.366	1
6	Disco intermedio	Inner plate	180.017.269	2
7	Disco sagomato	Intermediate plate	180.019.115	1
8	Disco stringifrizione W (1100 Nm)	Pressure plate W (1100 Nm)	180.017.282	1
	Disco stringifrizione W (1500 Nm)	Pressure plate W (1500 Nm)	180.017.282	1
	Disco stringifrizione W (1800 Nm)	Pressure plate W (1800 Nm)	180.013.451	1
9	Molla a tazza (1100 Nm)	Belleville spring (1100 Nm)	190.000.594	1
	Molla a tazza (1500 Nm)	Belleville spring (1500 Nm)	190.000.607	1
	Molla a tazza (1800 Nm)	Belleville spring (1800 Nm)	190.000.855	1
10	Disco d'arresto W	Stop ring W	180.017.276	1
11	Kit vite M14x1,5x100 + dado	Bolt M14x1,5x100+nut	165.000.622	2
12	Ponti di blocco	Clamp lock	151.014.201	2
13	Kit ponti di blocco 1 3/4"	Clamp lock set 1 3/4"	165.000.692	1

* Quantità presente nel dispositivo
 Quantity in the Safety Device

FRIZIONE SEMIAPERTA A DISCHI MULTIPLI HALF OPENED DISC CLUTCH TORQUE LIMITER

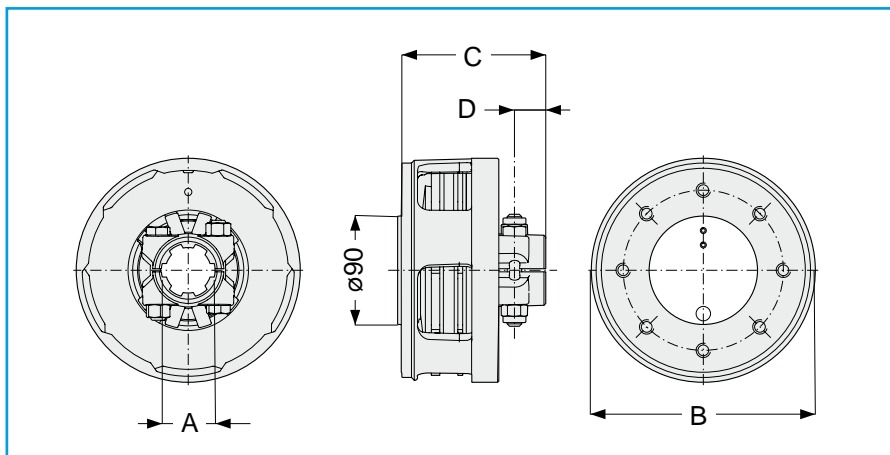
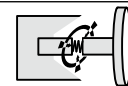

JF

Type	Ref.	A	B		C		D		MAX		Code
			[mm]	[inch]	[mm]	[inch]	[mm]	[inch]	[Nm]	[in.lb]	
60	J42F	1 3/8" z6	186	7 21/64"	120	4 23/32"	26	1 1/32"	1600	14100	148.304.511.1
	J43F	1 3/8" z21	186	7 21/64"	120	4 23/32"	26	1 1/32"	1600	14100	148.304.512.1
	J44F	1 3/4" z6	186	7 21/64"	120	4 23/32"	26	1 1/32"	1600	14100	148.304.513.1
	J45F	1 3/4" z20	186	7 21/64"	120	4 23/32"	26	1 1/32"	1600	14100	148.304.514.1
80	J42F	1 3/8" z6	186	7 21/64"	120	4 23/32"	26	1 1/32"	2000	17700	148.304.515.1
	J43F	1 3/8" z21	186	7 21/64"	120	4 23/32"	26	1 1/32"	2000	17700	148.304.516.1
	J44F	1 3/4" z6	186	7 21/64"	120	4 23/32"	26	1 1/32"	2000	17700	148.304.517.1
	J45F	1 3/4" z20	186	7 21/64"	120	4 23/32"	26	1 1/32"	2000	17700	148.304.518.1
90	J42F	1 3/8" z6	186	7 21/64"	120	4 23/32"	26	1 1/32"	2400	21200	148.304.519.1
	J43F	1 3/8" z21	186	7 21/64"	120	4 23/32"	26	1 1/32"	2400	21200	148.304.520.1
	J44F	1 3/4" z6	186	7 21/64"	120	4 23/32"	26	1 1/32"	2400	21200	148.304.521.1
	J45F	1 3/4" z20	186	7 21/64"	120	4 23/32"	26	1 1/32"	2400	21200	148.304.522.1
120	J44F	1 3/4" z6	186	7 21/64"	120	4 23/32"	26	1 1/32"	3300	29000	148.304.526.1
	J45F	1 3/4" z20	186	7 21/64"	120	4 23/32"	26	1 1/32"	3300	29000	148.304.527.1
	J44F	1 3/4" z6	186	7 21/64"	120	4 23/32"	26	1 1/32"	3300	29000	148.304.526.1

FRIZIONE SEMIAPERTA A DISCHI MULTIPLI HALF OPENED DISC CLUTCH TORQUE LIMITER

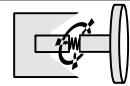

La frizione "chiusa" a dischi multipli JF interviene quando la coppia di lavoro supera la coppia di taratura. Durante la fase di limitazione del picco di coppia la frizione continua a trasmettere potenza. La frizione è utilizzabile sia come dispositivo di sicurezza contro picchi di coppia sia per avviare macchine con elevata inerzia rotazionale. Questo tipo di frizione risulta avere la taratura non modificabile ed inoltre l'utilizzo di speciali molle a tazza in luogo delle più comuni molle elicoidali rende costante la taratura nonostante il progressivo consumo dei dischi d'attrito.

The closed disc clutch torque limiter JF is activated when the setting torque exceeds the calibration torque. During the torque peak limiting phase, the clutch keeps on transmitting power. The clutch can be used both as safety device to protect against load peaks and to start machines with high rotational inertia. The torque setting of this clutch is not adjustable and the use of special Belleville springs instead of the helical springs ensures a stable torque setting compensating for the natural wear of the friction linings.

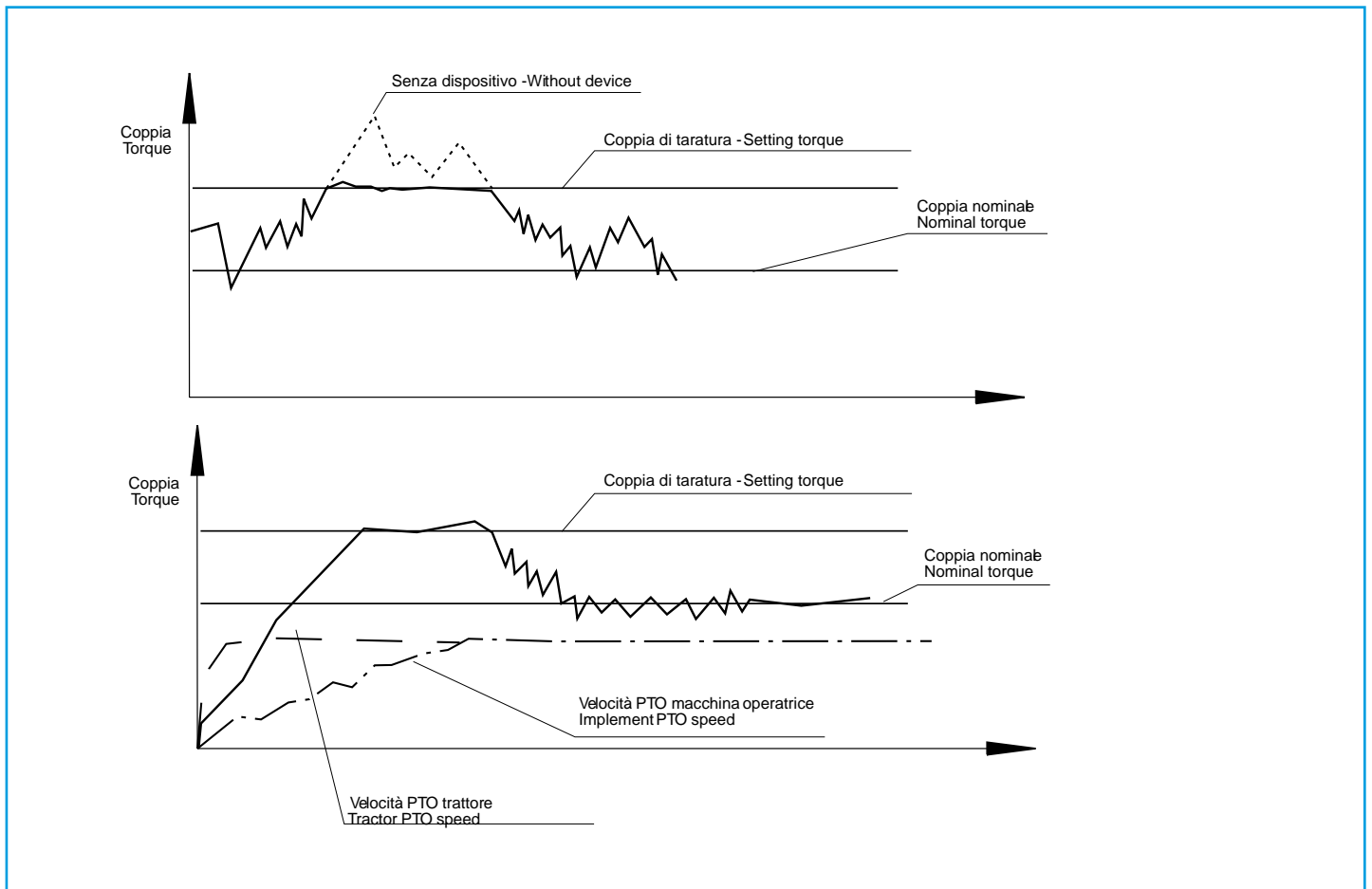

Le frizioni possono raggiungere elevate temperature.

Non toccare!

Per evitare rischi di incendio, mantenere la zona adiacente la frizione pulita da materiale infiammabile ed evitare slittamenti prolungati.

Friction clutches may become hot during use.

Do not touch!

Keep the area around the friction clutch clear of any material which could catch fire and avoid prolonged slipping.

FRIZIONE SEMIAPERTA A DISCHI MULTIPLI HALF OPENED DISC CLUTCH TORQUE LIMITER

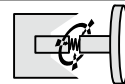

JF

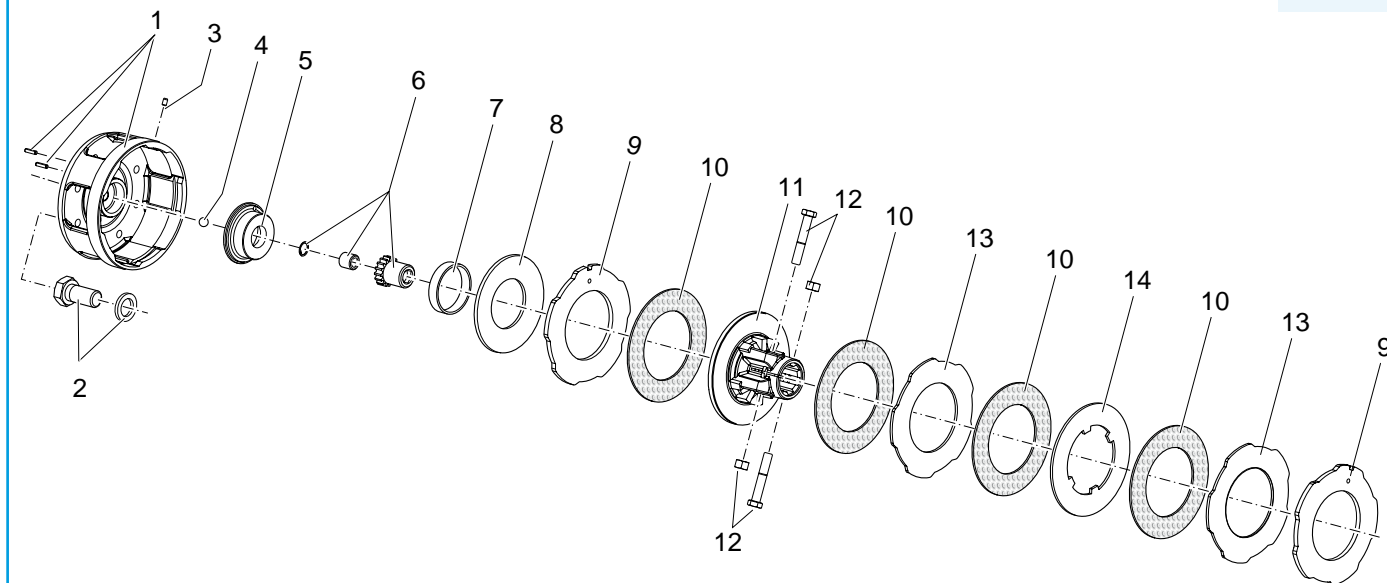

Pos.			Code	Qty *
1	Fondello corpo JF	Outer casing JF	141.027.285.1	1
2	Kit vite M12x1,25x55 + dado	Bolt M12x1,25x25+nut	165.000.708	8
3	Grano M6x12	Screw M6x12	190.000.617	1
4	Sfera 1/2"	Ball 1/2"	190.000.078	1
5	Anello centraggio	Pilot ring	151.017.370	1
6	Sistema di registrazione	Setting system	165.000.758	1
7	Bronzina frizione	Bush	180.017.369	1
8	Molla a tazza < 2800 Nm	Belleville spring < 2800 Nm	190.000.607	1
	Molla a tazza > 2800 Nm	Belleville spring > 2800 Nm	190.000.620	1
9	Disco spingi frizione/arresto	Pressure plate/stop ring	180.017.288	2
10	Disco d'attrito	Lining ring	180.019.333	4
11	Mozzo frizione J42	Clutch support J42	151.017.391.1	1
	Mozzo frizione J43	Clutch support J43	151.017.392.1	1
	Mozzo frizione J44	Clutch support J44	151.017.372.1	1
	Mozzo frizione J45	Clutch support J45	151.017.393.1	1
12	Vite M12x1,25x75 + dado	Bolt M12x1,25x75+nut	165.000.598	2
13	Disco intermedio	Inner plate	180.017.291	2
14	Disco sagomato	Intermediate plate	180.019.334	1

Dispositivi di sicurezza flangiati
Modular Safety Devices

* Quantità presente nel dispositivo
Quantity in the Safety Device

FRIZIONE SEMIAPERTA CON RUOTA LIBERA
HALF OPENED DISC CLUTCH TORQUE LIMITER WITH OVERRUNNING CLUTCH

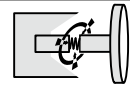

RJ6F - RJ7F

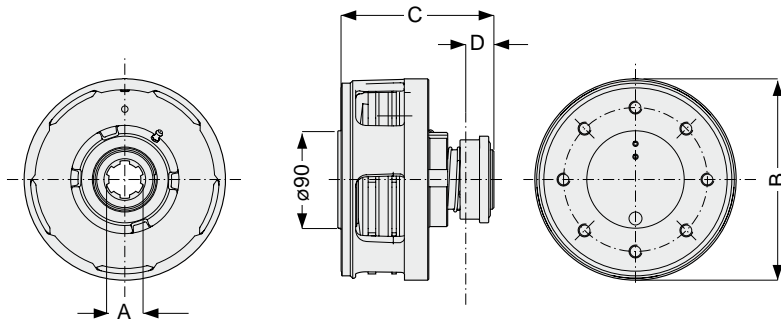

RJ8F - RJ9F

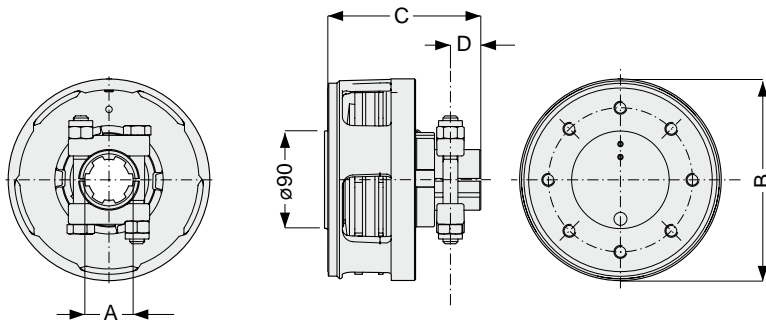

RJF



Type	Ref.	A		B		C		D		MAX		Code
		[mm]	[inch]	[mm]	[inch]	[mm]	[inch]	[mm]	[inch]	[Nm]	[in.lb]	
60	RJ6F	1 3/8" z6	186	7 21/64"	141	5 35/64"	26	1 1/32"	1600	14100	148.404.501.1	
	RJ7F	1 3/8" z21	186	7 21/64"	141	5 35/64"	26	1 1/32"	1600	14100	148.404.502.1	
	RJ8F	1 3/4" z6	186	7 21/64"	141	5 35/64"	28	1 7/64"	1600	14100	148.404.503.1	
	RJ9F	1 3/4" z20	186	7 21/64"	141	5 35/64"	28	1 7/64"	1600	14100	148.404.504.1	
80	RJ6F	1 3/8" z6	186	7 21/64"	141	5 35/64"	26	1 1/32"	2000	17700	148.404.505.1	
	RJ7F	1 3/8" z21	186	7 21/64"	141	5 35/64"	26	1 1/32"	2000	17700	148.404.506.1	
	RJ8F	1 3/4" z6	186	7 21/64"	141	5 35/64"	28	1 7/64"	2000	17700	148.404.507.1	
	RJ9F	1 3/4" z20	186	7 21/64"	141	5 35/64"	28	1 7/64"	2000	17700	148.404.508.1	
90	RJ6F	1 3/8" z6	186	7 21/64"	141	5 35/64"	26	1 1/32"	2400	21200	148.404.509.1	
	RJ7F	1 3/8" z21	186	7 21/64"	141	5 35/64"	26	1 1/32"	2400	21200	148.404.510.1	
	RJ8F	1 3/4" z6	186	7 21/64"	141	5 35/64"	28	1 7/64"	2400	21200	148.404.511.1	
	RJ9F	1 3/4" z20	186	7 21/64"	141	5 35/64"	28	1 7/64"	2400	21200	148.404.512.1	
	RJ8F	1 3/4" z6	186	7 21/64"	141	5 35/64"	28	1 7/64"	3300	29000	148.404.515.1	
120	RJ9F	1 3/4" z20	186	7 21/64"	141	5 35/64"	28	1 7/64"	3300	29000	148.404.516.1	

NOTA: fornibile a richiesta per senso di rotazione antiorario
NOTE: available upon request for anti-clockwise direction of rotation

FRIZIONE SEMIAPERTA CON RUOTA LIBERA HALF OPENED DISC CLUTCH TORQUE LIMITER WITH OVERRUNNING CLUTCH



Il dispositivo comprende un limitatore di coppia a dischi d'attrito (frizione) e una ruota libera integrati. La funzionalità assomma quelle dei singoli dispositivi con il vantaggio di risparmiare spazio e di consentire il montaggio sullo stesso lato del cardano. Il dispositivo è utile come organo di sicurezza contro picchi di carico e in macchine con grosse masse rotanti, sia durante l'avviamento che durante l'arresto, evitando inutili sollecitazioni della PTO del trattore. Questo tipo di frizione risulta avere la taratura non modificabile ed inoltre l'utilizzo di speciali molle a tazza in luogo delle più comuni molle elicoidali rende costante la taratura nonostante il progressivo consumo dei dischi d'attrito.

The device includes a disc clutch torque limiter and an incorporated overrunning clutch. The device combines the functions of the single devices thus reducing space and allowing it to be mounted on the same side of the cardan. It is useful as a safety device to protect against load peaks and in implements with large rotating mass during start-up and stopping operations, thus avoiding unnecessary stress on the tractor PTO. The torque setting of this clutch is not adjustable and the use of special Belleville springs instead of the helical springs ensures a stable torque setting compensating for the natural wear of the friction linings.

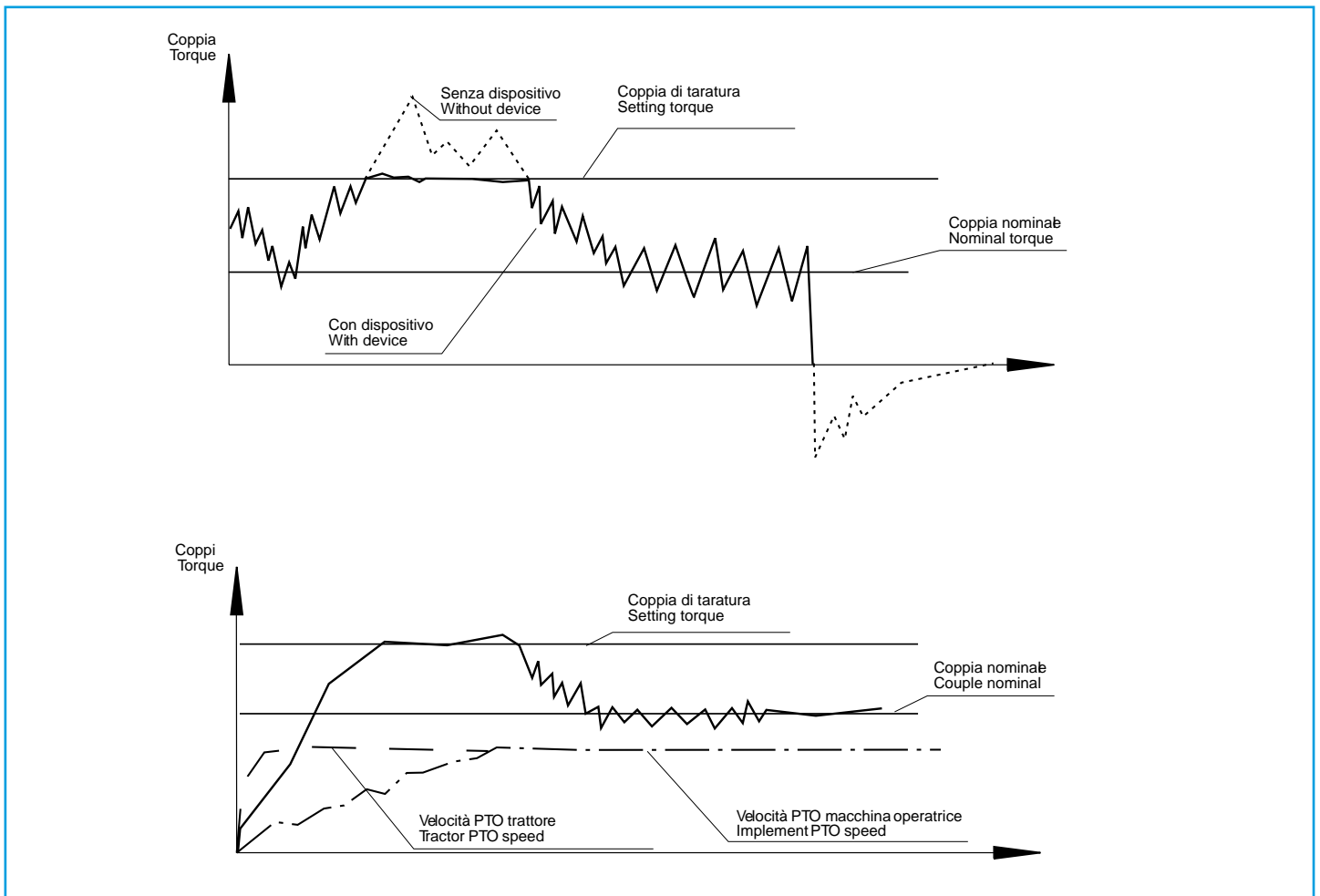

Le frizioni possono raggiungere elevate temperature.

Non toccare!

Per evitare rischi di incendio, mantenere la zona adiacente la frizione pulita da materiale infiammabile ed evitare slittamenti prolungati.

Friction clutches may become hot during use.

Do not touch!

Keep the area around the friction clutch clear of any material which could catch fire and avoid prolonged slipping.

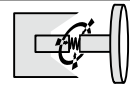

RJ6F / RJ7F

RJF

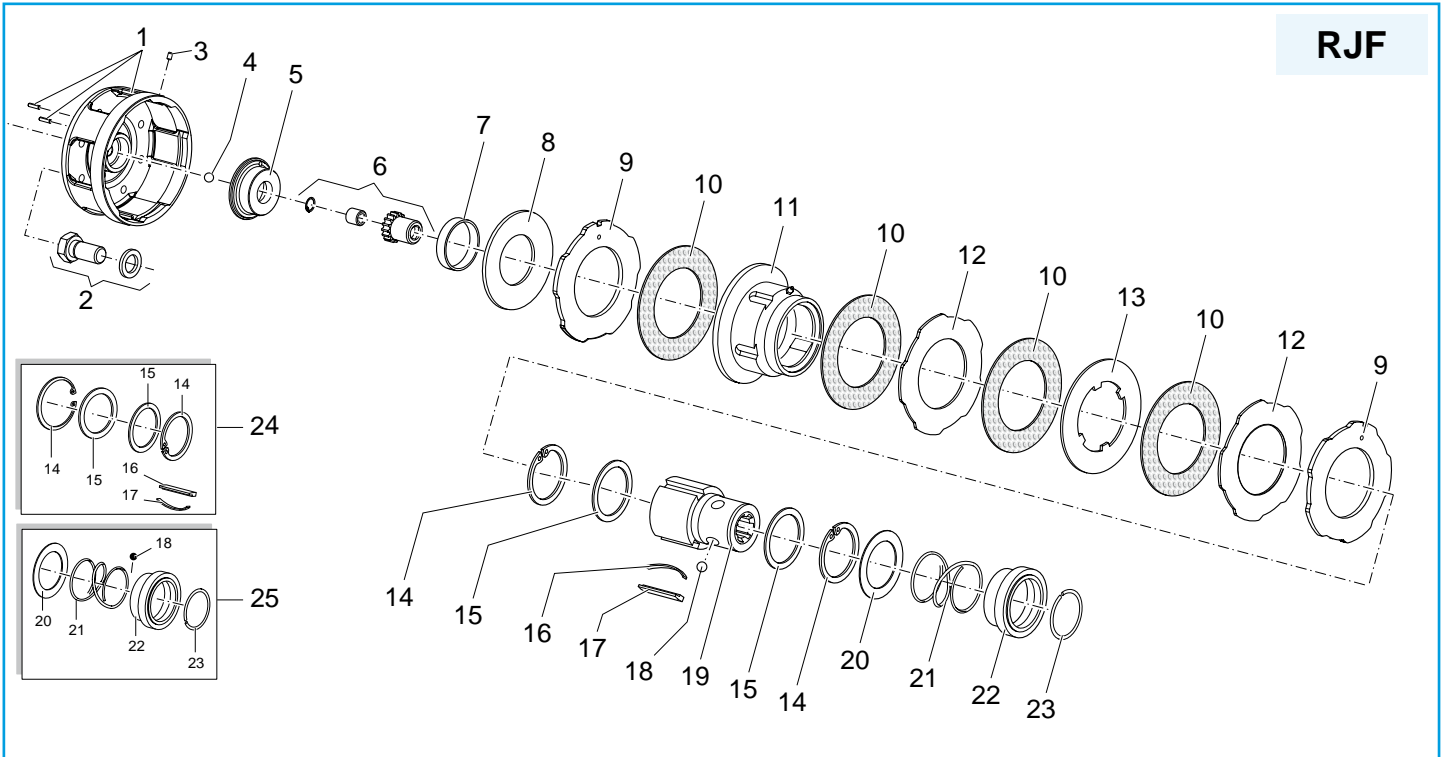

Pos.			Code	Qty *
1	Fondello corpo RJF	Outer casing RJF	141.027.285.1	1
2	Viti M12x1.25x25 + rondelle	Bolt M12x1,25x25+nut	165.000.708	8
3	Grano UNI 5923-M6x12-45H	Screw UNI 5923-M6x12-45H	190.000.617	1
4	Sfera 1/2"	Ball 1/2"	190.000.078	1
5	Anello centraggio	Pilot ring	151.017.370	1
6	Sistema di registrazione	Setting system	165.000.758	1
7	Bronzina frizione	Bush	180.017.369	1
8	Molla a tazza	Belleville spring	190.000.607	1
9	Disco spingi frizione/arresto	Pressure plate/stop ring	180.017.288	2
10	Disco d'attrito $\varnothing 162 \times \varnothing 100$	Lining ring $\varnothing 162 \times \varnothing 100$	180.019.333	4
11	Corpo RJ	Torque limiter support RJ	141.027.374	1
12	Disco intermedio	Inner plate	180.017.291	2
13	Disco sagomato	Intermediate plate	180.019.334	1
14	Seeger	Snap ring	190.000.183	2
15	Anello di rasamento	Retaining washer ring	180.014.135	2
16	Molla a balestra	Leaf spring	180.014.137	3
17	Linguetta	Ratchet	151.014.136	3
18	Sfera 1/2"	Ball 1/2"	190.000.078	3
19	Mozzo R12	Hub R12	151.016.546	1
	Mozzo R13	Hub R13	151.016.571	1
20	Lamierino	Spring push ring	180.015.143	1
21	Molla collar	Collar spring	180.016.487	1
22	Manicotto collar	Sliding sleeve collar	151.016.486	1
23	Seeger	Snap ring	190.000.451	1
24	Kit RF - RJ	Kit RF - RJ	165.000.741	1
25	Kit collar R12-R13	Kit collar R12-R13	165.000.653	1

* Quantità presente nel dispositivo
 Quantity in the Safety Device

FRIZIONE SEMIAPERTA CON RUOTA LIBERA
HALF OPENED DISC CLUTCH TORQUE LIMITER WITH OVERRUNNING CLUTCH



RJ8F / RJ9F

RJF

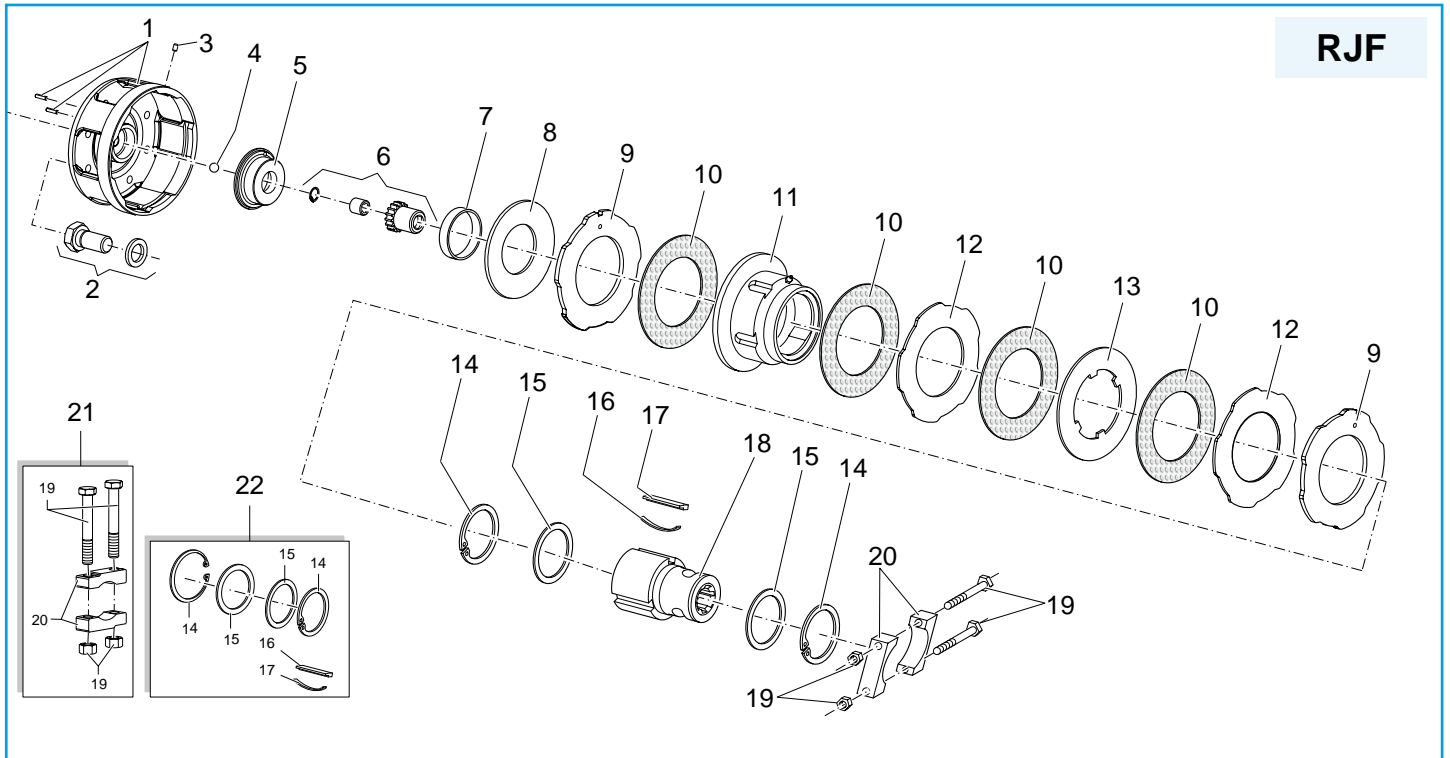

Pos.			Code	Qty *
1	Fondello corpo RJF	Outer casing RJF	141.027.285.1	1
2	Viti M12x1.25x25 + rondelle	Bolt M12x1,25x25+nut	165.000.708	8
3	Grano UNI 5923-M6x12-45H	Screw UNI 5923-M6x12-45H	190.000.617	1
4	Sfera 1/2"	Ball 1/2"	190.000.078	1
5	Anello centraggio	Pilot ring	151.017.370	1
6	Sistema di registrazione	Setting system	165.000.758	1
7	Bronzina frizione	Bush	180.017.369	1
8	Molla a tazza	Belleville spring	190.000.607	1
9	Disco spingi frizione/arresto	Pressure plate/stop ring	180.017.288	2
10	Disco d'attrito ø162xø100	Lining ring ø162xø100	180.019.333	4
11	Corpo RJ	Torque Limiter support RJ	141.027.374	1
12	Disco intermedio	Inner plate	180.017.291	2
13	Disco sagomato	Intermediate plate	180.019.334	1
14	Seeger	Snap ring	190.000.183	2
15	Anello di rasamento	Retaining washer ring	180.014.135	2
16	Molla a balestra	Leaf spring	180.014.137	3
17	Linguetta	Ratchet	151.014.136	3
18	Mozzo R14	Hub R14	151.014.200	1
	Mozzo R15	Hub R15	151.018.121	1
19	Vite M14x1,5x100 + dado	Bolt M14x1,5x100+nut	165.000.622	2
20	Ponte di blocco	Clamp lock	151.014.201	2
21	Kit ponti di blocco 1 3/4"	Clamp lock set 1 3/4"	165.000.692	1
22	Kit RF - RJ	Kit RF - RJ	165.000.741	1

Dispositivi di sicurezza flangiati
Modular Safety Devices

* Quantità presente nel dispositivo
Quantity in the Safety Device

LIMITATORE AUTOMATICO CON RUOTA LIBERA AUTOMATIC TORQUE LIMITER WITH OVERRUNNING CLUTCH

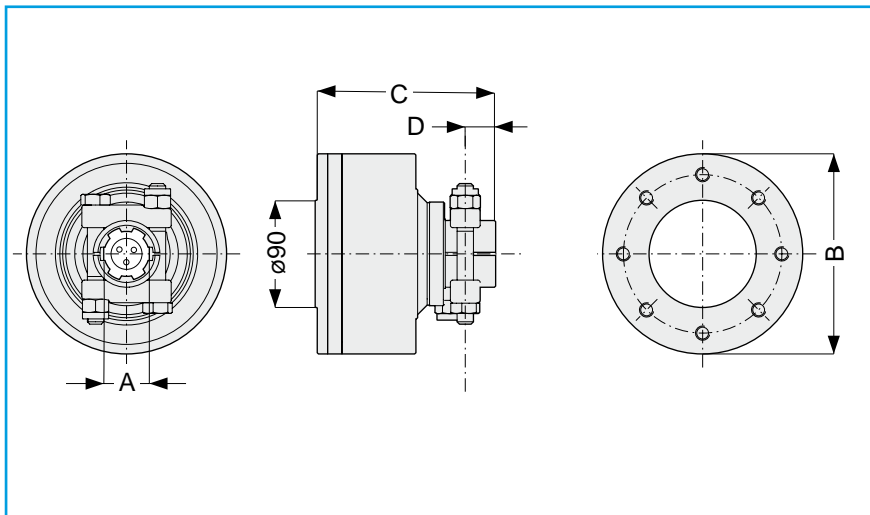
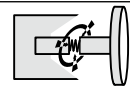

Type	Ref.	A		B		C		D		MAX		Code
		[mm]	[inch]	[mm]	[inch]	[mm]	[inch]	[mm]	[inch]	[Nm]	[in.lb]	
60	LR2F	1 3/8" z6	168	6 39/64"	149	5 7/8"	28	1 7/64"	2500	22100	144.406.001.1	
	LR3F	1 3/8" z21	168	6 39/64"	149	5 7/8"	28	1 7/64"	2500	22100	144.406.002.1	
	LR4F	1 3/4" z6	168	6 39/64"	149	5 7/8"	28	1 7/64"	2500	22100	144.406.003.1	
	LR5F	1 3/4" z20	168	6 39/64"	149	5 7/8"	28	1 7/64"	2500	22100	144.406.004.1	
80 90	120	LR2F	1 3/8" z6	168	6 39/64"	149	5 7/8"	28	1 7/64"	3000	26500	144.406.005.1
		LR3F	1 3/8" z21	168	6 39/64"	149	5 7/8"	28	1 7/64"	3000	26500	144.406.006.1
		LR4F	1 3/4" z6	168	6 39/64"	149	5 7/8"	28	1 7/64"	3000	26500	144.406.007.1
		LR5F	1 3/4" z20	168	6 39/64"	149	5 7/8"	28	1 7/64"	3000	26500	144.406.008.1
		LR4F	1 3/4" z6	168	6 39/64"	149	5 7/8"	28	1 7/64"	3500	30900	144.406.009.1
		LR5F	1 3/4" z20	168	6 39/64"	149	5 7/8"	28	1 7/64"	3500	30900	144.406.010.1

Il dispositivo comprende un limitatore a reinnesto automatico Comer e una ruota libera integrati e consente la trasmissione del moto in un solo senso di rotazione. La funzionalità assomma quelle dei singoli dispositivi con il vantaggio di risparmiare spazio e di consentire il montaggio sullo stesso lato del cardano. Il dispositivo è utile come organo di sicurezza contro picchi di carico e in macchine con grosse masse inerziali. Al raggiungimento della soglia di intervento come limitatore, la coppia trasmessa viene ridotta a valori minimi interrompendo di fatto la trasmissione del moto che viene ripristinata automaticamente mediante una diminuzione del regime di rotazione della PTO del trattore e la contemporanea eliminazione della causa esterna. La ruota libera entra in funzione nella fase di arresto facendo sì che la PTO del trattore non venga trascinata dalla macchina operatrice.

The device consists of an integrated Comer automatic torque limiter plus an overrunning clutch, transmitting motion in a single rotation direction. Overall operating capacity is based on the sum of the outputs of the individual devices with the added advantage that it saves space and can be mounted on the same side of the driveshaft. It can be used as a safety device to offset load peaks and in machines with large inertial masses. When the device reaches the limiter tripping threshold, the transmitted torque is reduced to minimum values, cutting off the transmission motion. The motion is restored automatically by reducing the rotation of the tractor PTO while simultaneously eliminating the external cause. The overrunning clutch begins operating during the stop phase, while preventing the tractor PTO from being entrained by the application.

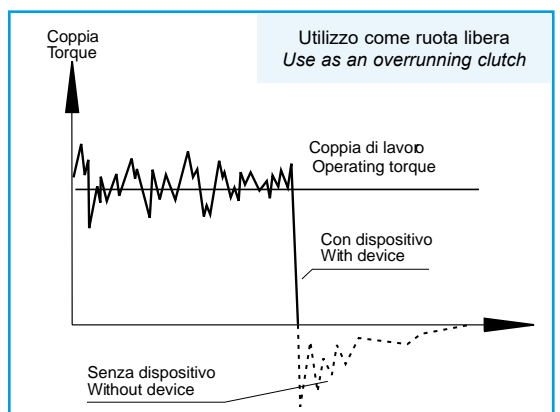
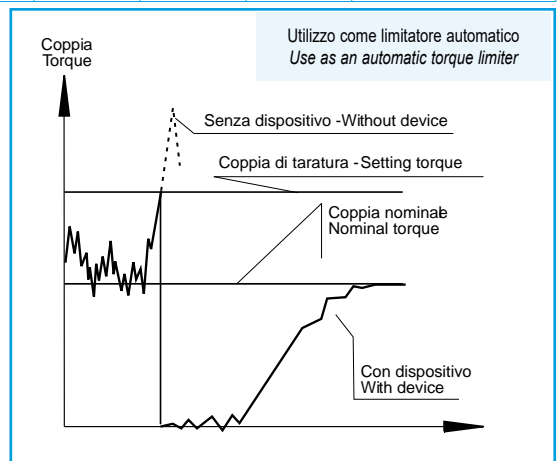

NOTA: fornibile a richiesta per senso di rotazione antiorario
NOTE: available upon request for anti-clockwise direction of rotation

LIMITATORE AUTOMATICO CON RUOTA LIBERA AUTOMATIC TORQUE LIMITER WITH OVERRUNNING CLUTCH

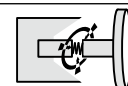

LRF

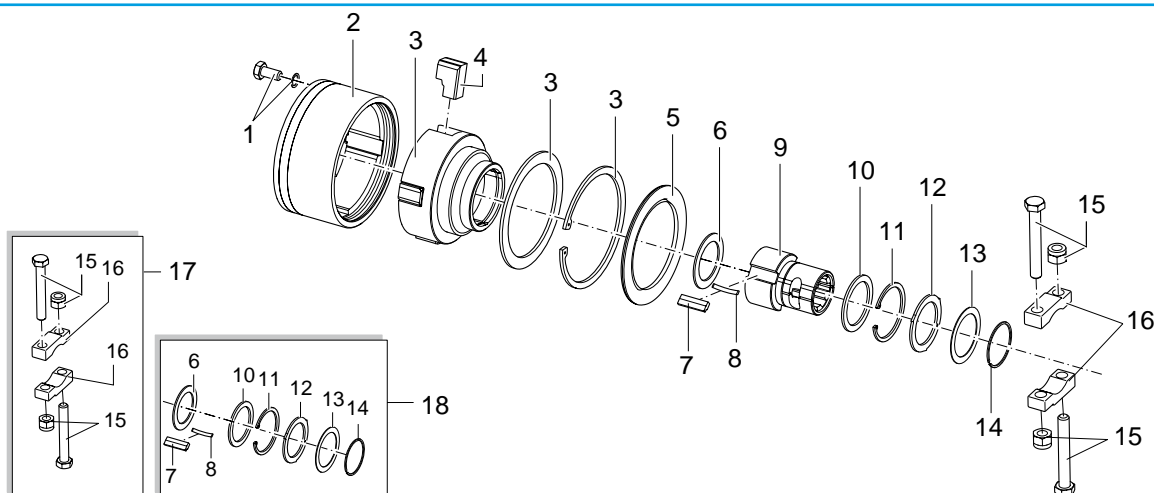

Pos.			Code	Qty *
1	Vite M12x1,25x25 + rondella	Bolt M12x1,25x25 + washer	165.000.708	8
2	Fondello corpo	Outer casing	141.028.411.1	1
3	Kit mozzo LR2F - 2500 Nm	Hub set LR2F - 2500 Nm	165.000.771	1
	Kit mozzo LR3F - 2500 Nm	Hub set LR3F - 2500 Nm	165.000.772	1
	Kit mozzo LR4F - 2500 Nm	Hub set LR4F - 2500 Nm	165.000.773	1
	Kit mozzo LR5F - 2500 Nm	Hub set LR5F - 2500 Nm	165.000.774	1
	Kit mozzo LR2F - 3000 Nm	Hub set LR2F - 3000 Nm	165.000.775	1
	Kit mozzo LR3F - 3000 Nm	Hub set LR3F - 3000 Nm	165.000.776	1
	Kit mozzo LR4F - 3000 Nm	Hub set LR4F - 3000 Nm	165.000.777	1
	Kit mozzo LR5F - 3000 Nm	Hub set LR5F - 3000 Nm	165.000.778	1
	Kit mozzo LR4F - 3500 Nm	Hub set LR4F - 3500 Nm	165.000.779	1
	Kit mozzo LR5F - 3500 Nm	Hub set LR5F - 3500 Nm	165.000.780	1
4	Linguetta (tipo 60)	Ratchet (type 60)	151.018.376	4
	Linguetta (tipo 80-90)	Ratchet (type 80-90)	151.018.390	4
5	Paragrasso	Grease protection	180.018.400	1
6	Distanziale	Retaining Washers	190.000.199	1
7	Linguetta	Ratchet	151.014.136	2
8	Molla a balestra	Leaf Spring	180.014.137	2
	Mozzo 1 3/8" z6	Hub 1 3/8" z6	151.017.394	1
	Mozzo 1 3/8" z21	Hub 1 3/8" z21	151.017.395	1
	Mozzo 1 3/4" z6	Hub 1 3/4" z6	151.017.387	1
9	Mozzo 1 3/4" z20	Hub 1 3/4" z20	151.017.396	1
	Anello di rasamento	Retaining washer ring	151.014.135	1
10	Seeger	Circlip	190.000.183	1
11	Paragrasso per ruota libera	Grease protection	180.017.388	1
12	Lamierino	Spring push ring	180.015.143	1
13	Seeger	Circlip	190.000.079	1
14	Viti M12x1.25x95 (1 3/8")	Bolt M12x1.25x95 (1 3/8")	165.000.782	2
	Viti M14x1.5x100 (1 3/4")	Bolt M14x1.5x100 (1 3/4")	165.000.622	2
15	Ponti di blocco 1 3/8"	Clamp lock 1 3/8"	151.016.525	2
	Ponti di blocco 1 3/4"	Clamp lock 1 3/4"	151.014.201	2
16	Kit ponti di blocco 1 3/8"	Clamp lock set 1 3/8"	165.000.783	1
	Kit ponti di blocco 1 3/4"	Clamp lock set 1 3/4"	165.000.692	1
17	Kit LR	Kit LR	165.000.781	1

Dispositivi di sicurezza flangiati
Modular Safety Devices

* Quantità presente nel dispositivo
Quantity in the Safety Device

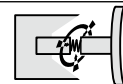

Identificazione prodotto / Product Identification

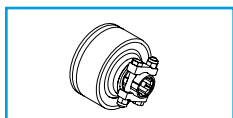

2 5 C 1 5 9 B D

15=1500 Nm	29=2900 Nm
16=1600 Nm	30=3000 Nm
17=1700 Nm	31=3100 Nm
18=1800 Nm	32=3200 Nm
19=1900 Nm	33=3300 Nm
20=2000 Nm	34=3400 Nm
21=2100 Nm	35=3500 Nm
22=2200 Nm	36=3600 Nm
23=2300 Nm	37=3700 Nm
24=2400 Nm	38=3800 Nm
25=2500 Nm	39=3900 Nm
26=2600 Nm	40=4000 Nm
27=2700 Nm	
28=2800 Nm	

Mese di produzione <i>Production month</i>	
A =	Gen <i>Jan</i>
B =	Feb <i>Feb</i>
C =	Mar <i>Mar</i>
D =	Apr <i>Apr</i>
E =	Mag <i>May</i>
F =	Giu <i>Jun</i>
G =	Lug <i>Jul</i>
H =	Ago <i>Aug</i>
I =	Set <i>Sep</i>
J =	Ott <i>Oct</i>
K =	Nov <i>Nov</i>
L =	Dic <i>Dec</i>

Numero progressivo del pezzo <i>Parts progressive number</i>	
N	

Anno di produzione <i>Production year</i>	
A =	2019
B =	2020
C =	2021
D =	2022
E =	2023
F =	2024
G =	2025
H =	2026
I =	2027
etc.	

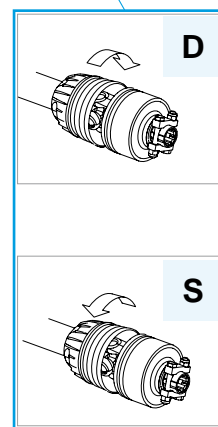



Questa pagina è lasciata intenzionalmente bianca
This page is intentionally left blank

PROTEZIONI GUARDS

		p.
CODIFICA D'ORDINE PROTEZIONI GUARDS ORDER CODE		121
PROTEZIONI F-CE PER CARDANI OMOCINETICI CVJ F-CE GUARDS FOR PTO DRIVESHAFTS CVJ		
Protezioni complete doppio CVJ - Serie V	<i>Complete guards double CVJ - Series V</i>	122
Protezioni complete singolo CVJ - Serie V	<i>Complete guards single CVJ - Series V</i>	123
Protezioni complete doppio CVJ - Serie T	<i>Complete guards double CVJ - Series T</i>	124
Protezioni complete singolo CVJ - Serie T	<i>Complete guards single CVJ - Series T</i>	125
Semi protezioni esterne/interne	<i>Half-guards Outer/Inner</i>	126
PROTEZIONI F-CE PER CARDANI F-CE GUARDS FOR PTO DRIVESHAFTS		
Protezioni complete	<i>Complete Guards</i>	127
Semi protezioni esterne/interne	<i>Half-guards Outer/Inner</i>	128
ACCESSORI F-CE F-CE ACCESSORIES		
Cuffie - Ghiera - Bottoni - Catene	<i>Cones - Retaining collar - Bolts - Chains</i>	130
PROTEZIONI N-EN PER CARDANI OMOCINETICI CVJ N-EN GUARDS FOR PTO DRIVESHAFTS CVJ		
Protezioni complete doppio CVJ - Serie V	<i>Complete guards double CVJ - Series V</i>	132
Protezioni complete singolo CVJ - Serie V	<i>Complete guards single CVJ - Series V</i>	133
Protezioni complete doppio CVJ - Serie T	<i>Complete guards double CVJ - Series T</i>	134
Protezioni complete singolo CVJ - Serie T	<i>Complete guards single CVJ - Series T</i>	135
Semi protezioni esterne/interne	<i>Half-guards Outer/Inner</i>	136
PROTEZIONI N-EN PER CARDANI N-EN GUARDS FOR PTO DRIVESHAFTS		
Protezioni complete	<i>Complete Guards</i>	137
Semi protezioni esterne/interne	<i>Half-guards Outer/Inner</i>	138
ACCESSORI N-EN N-EN ACCESSORIES		
Cuffie - Ghiera - Bottoni - Catene	<i>Cones - Retaining collar - Bolt - Chains</i>	140
CONTROCUFFIE COUNTER-CONES		
Controcuffie fisse	<i>Fixed Counter-Cones</i>	142
Controcuffie amovibili	<i>Removable Counter-Cones</i>	143
Esempi d'applicazione	<i>Application examples</i>	144

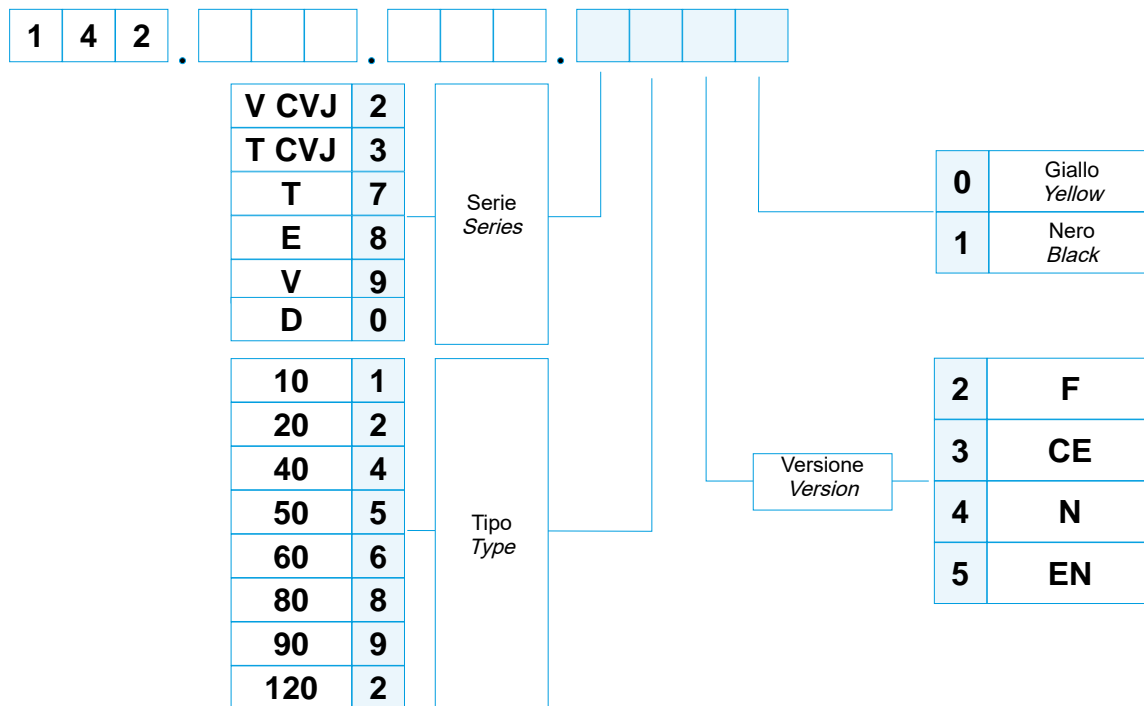
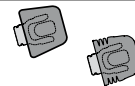

Le protezioni sono fornibili a richiesta, con applicate decalcomanie tipo:
 - USA - CANADA -

The guards can be supplied on request with the following decals included:
 - USA - CANADA -

PROTEZIONI COMPLETE DOPPIO CVJ - SERIE V
COMPLETE GUARDS DOUBLE CVJ - SERIE V

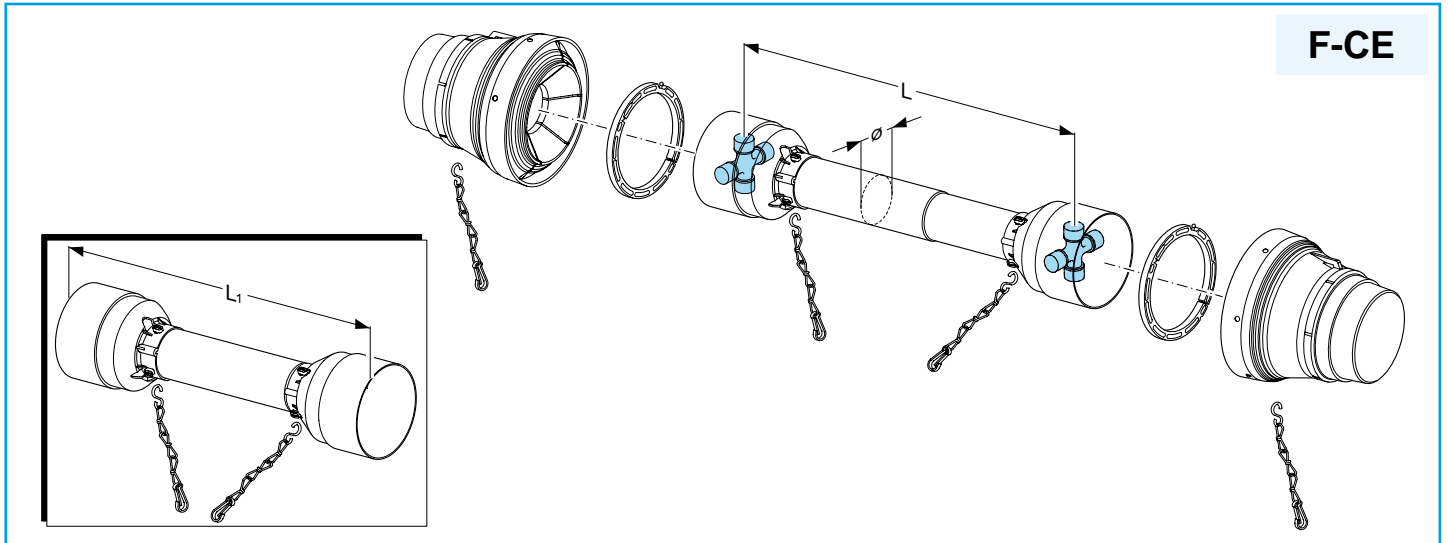
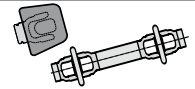

Type	ø = 61 mm 20		ø = 66.5 mm 40		ø = 81.2 mm 60		ø = 96 mm 80	
	L ₁ [mm]	Code	L ₁ [mm]	Code	L ₁ [mm]	Code	L ₁ [mm]	Code
L = 410	340	142.922.001.2231	355	142.942.001.2431	350	142.962.004.2631	330	142.982.003.2831
L = 460	390	142.922.002.2231	405	142.942.002.2431	400	142.962.005.2631	380	142.982.004.2831
L = 510	440	142.922.003.2231	455	142.942.003.2431	450	142.962.006.2631	430	142.982.005.2831
L = 560	490	142.922.004.2231	505	142.942.004.2431	500	142.962.007.2631	480	142.982.006.2831
L = 610	540	142.922.005.2231	555	142.942.005.2431	550	142.962.008.2631	530	142.982.007.2831
L = 660	590	142.922.006.2231	605	142.942.006.2431	600	142.962.009.2631	580	142.982.008.2831
L = 710	640	142.922.007.2231	655	142.942.007.2431	650	142.962.010.2631	630	142.982.009.2831
L = 760	690	142.922.008.2231	705	142.942.008.2431	700	142.962.011.2631	680	142.982.010.2831
L = 810	740	142.922.009.2231	755	142.942.009.2431	750	142.962.012.2631	730	142.982.011.2831
L = 860	790	142.922.010.2231	805	142.942.010.2431	800	142.962.013.2631	780	142.982.012.2831
L = 910	840	142.922.011.2231	855	142.942.011.2431	850	142.962.014.2631	830	142.982.013.2831
L = 1010	940	142.922.012.2231	955	142.942.012.2431	950	142.962.015.2631	930	142.982.014.2831
L = 1110	1040	142.922.013.2231	1055	142.942.013.2431	1050	142.962.016.2631	1030	142.982.015.2831
L = 1210	1140	142.922.014.2231	1155	142.942.014.2431	1150	142.962.001.2631	1130	142.982.001.2831
L = 1310	1240	142.922.015.2231	1255	142.942.015.2431	1250	142.962.017.2631	1230	142.982.016.2831
L = 1410	1340	142.922.016.2231	1355	142.942.016.2431	1350	142.962.018.2631	1330	142.982.017.2831

Per codifica e tipologia protezione vedere pag.
 For coding and guard typology see pag.

PROTEZIONI COMPLETE SINGOLO CVJ - SERIE V
COMPLETE GUARDS SINGLE CVJ - SERIE V

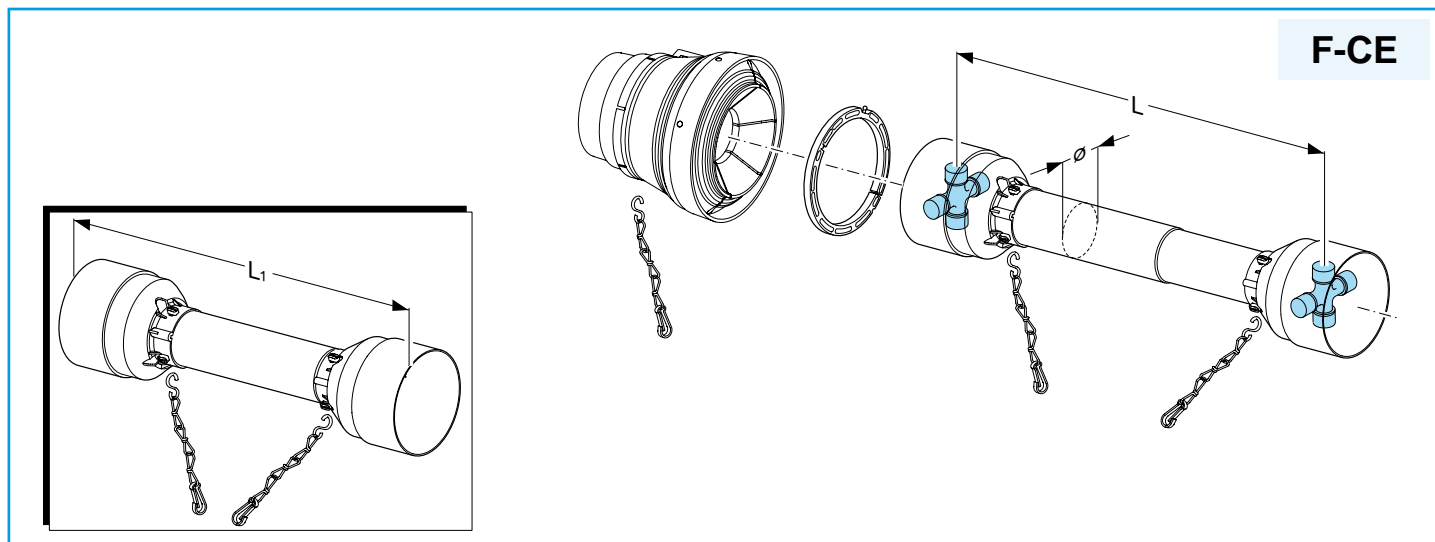
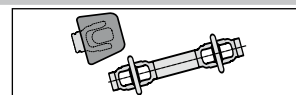

Type	ø = 61 mm 20		ø = 66.5 mm 40		ø = 81.2 mm 60		ø = 96 mm 80	
	L ₁ [mm]	Code	L ₁ [mm]	Code	L ₁ [mm]	Code	L ₁ [mm]	Code
L = 410	405	142.921.001.2231	410	142.941.001.2431	405	142.961.023.2631	415	142.981.031.2831
L = 460	455	142.921.002.2231	460	142.941.002.2431	455	142.961.035.2631	465	142.981.032.2831
L = 510	505	142.921.003.2231	510	142.941.003.2431	505	142.961.036.2631	515	142.981.033.2831
L = 560	555	142.921.004.2231	560	142.941.004.2431	555	142.961.037.2631	565	142.981.034.2831
L = 610	605	142.921.005.2231	610	142.941.005.2431	605	142.961.038.2631	615	142.981.035.2831
L = 660	655	142.921.006.2231	660	142.941.006.2431	655	142.961.039.2631	665	142.981.036.2831
L = 710	705	142.921.007.2231	710	142.941.007.2431	705	142.961.040.2631	715	142.981.037.2831
L = 760	755	142.921.008.2231	760	142.941.008.2431	755	142.961.022.2631	765	142.981.016.2831
L = 810	805	142.921.009.2231	810	142.941.009.2431	805	142.961.041.2631	815	142.981.038.2831
L = 860	855	142.921.010.2231	860	142.941.010.2431	855	142.961.006.2631	865	142.981.003.2831
L = 910	905	142.921.011.2231	910	142.941.011.2431	905	142.961.004.2631	915	142.981.005.2831
L = 1010	1005	142.921.012.2231	1010	142.941.012.2431	1005	142.961.018.2631	1015	142.981.039.2831
L = 1110	1105	142.921.013.2231	1110	142.941.013.2431	1105	142.961.008.2631	1115	142.981.040.2831
L = 1210	1205	142.921.014.2231	1210	142.941.014.2431	1205	142.961.019.2631	1215	142.981.015.2831
L = 1310	1305	142.921.015.2231	1310	142.941.015.2431	1305	142.961.020.2631	1315	142.981.041.2831
L = 1410	1405	142.921.016.2231	1410	142.941.016.2431	1405	142.961.017.2631	1415	142.981.042.2831

Per codifica e tipologia protezione vedere pag.
 For coding and guard tipology see pag.

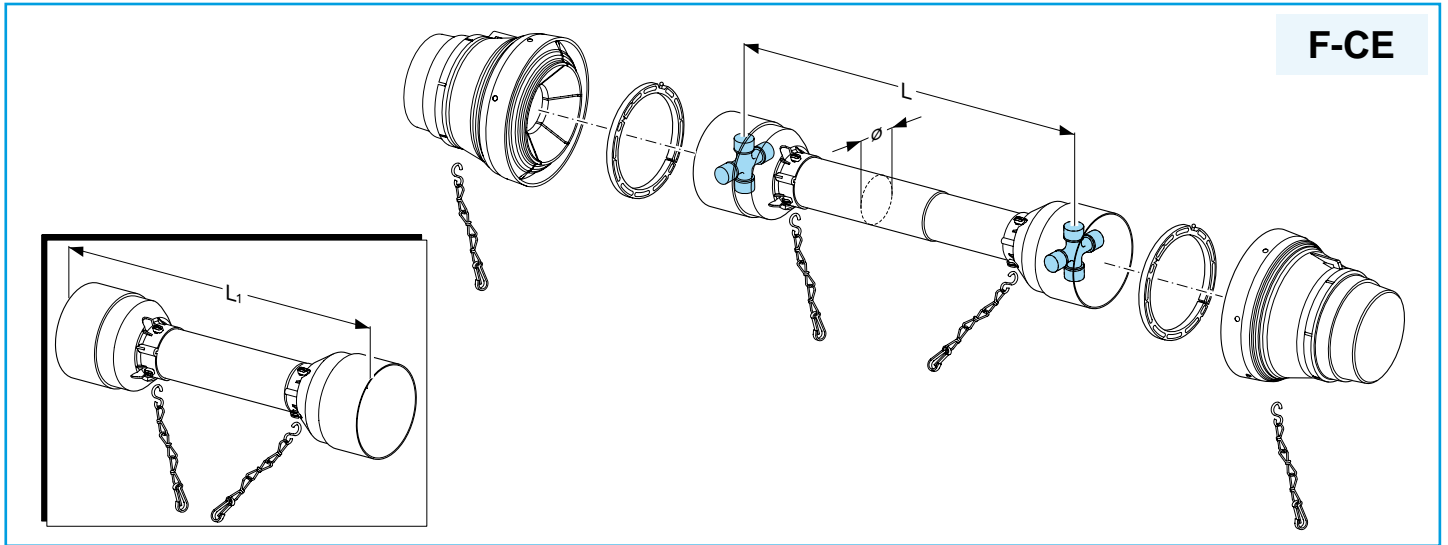
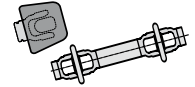

Type	ø = 61 mm 20		ø = 66.5 mm 40		ø = 81.2 mm 60		ø = 96 mm 80	
	L ₁ [mm]	Code	L ₁ [mm]	Code	L ₁ [mm]	Code	L ₁ [mm]	Code
L = 410	340	142.722.008.3231	355	142.742.014.3431	350	142.762.016.3631	330	142.782.010.3831
L = 460	390	142.722.003.3231	405	142.742.016.3431	400	142.762.017.3631	380	142.782.011.3831
L = 510	440	142.722.009.3231	455	142.742.009.3431	450	142.762.018.3631	430	142.782.012.3831
L = 560	490	142.722.010.3231	505	142.742.017.3431	500	142.762.009.3631	480	142.782.007.3831
L = 610	540	142.722.011.3231	555	142.742.008.3431	550	142.762.019.3631	530	142.782.013.3831
L = 660	590	142.722.004.3231	605	142.742.018.3431	600	142.762.005.3631	580	142.782.014.3831
L = 710	640	142.722.002.3231	655	142.742.019.3431	650	142.762.008.3631	630	142.782.015.3831
L = 760	690	142.722.012.3231	705	142.742.013.3431	700	142.762.010.3631	680	142.782.016.3831
L = 810	740	142.722.013.3231	755	142.742.003.3431	750	142.762.011.3631	730	142.782.017.3831
L = 860	790	142.722.014.3231	805	142.742.006.3431	800	142.762.002.3631	780	142.782.018.3831
L = 910	840	142.722.015.3231	855	142.742.004.3431	850	142.762.020.3631	830	142.782.019.3831
L = 1010	940	142.722.001.3231	955	142.742.007.3431	950	142.762.013.3631	930	142.782.002.3831
L = 1110	1040	142.722.016.3231	1055	142.742.005.3431	1050	142.762.004.3631	1030	142.782.006.3831
L = 1210	1140	142.722.017.3231	1155	142.742.001.3431	1150	142.762.007.3631	1130	142.782.020.3831
L = 1310	1240	142.722.007.3231	1255	142.742.015.3431	1250	142.762.003.3631	1230	142.782.009.3831
L = 1410	1340	142.722.018.3231	1355	142.742.020.3431	1350	142.762.021.3631	1330	142.782.008.3831

Per codifica e tipologia protezione vedere pag.
 For coding and guard tipology see pag.

PROTEZIONI COMPLETE SINGOLO CVJ - SERIE T
COMPLETE GUARDS SINGLE CVJ - SERIE T

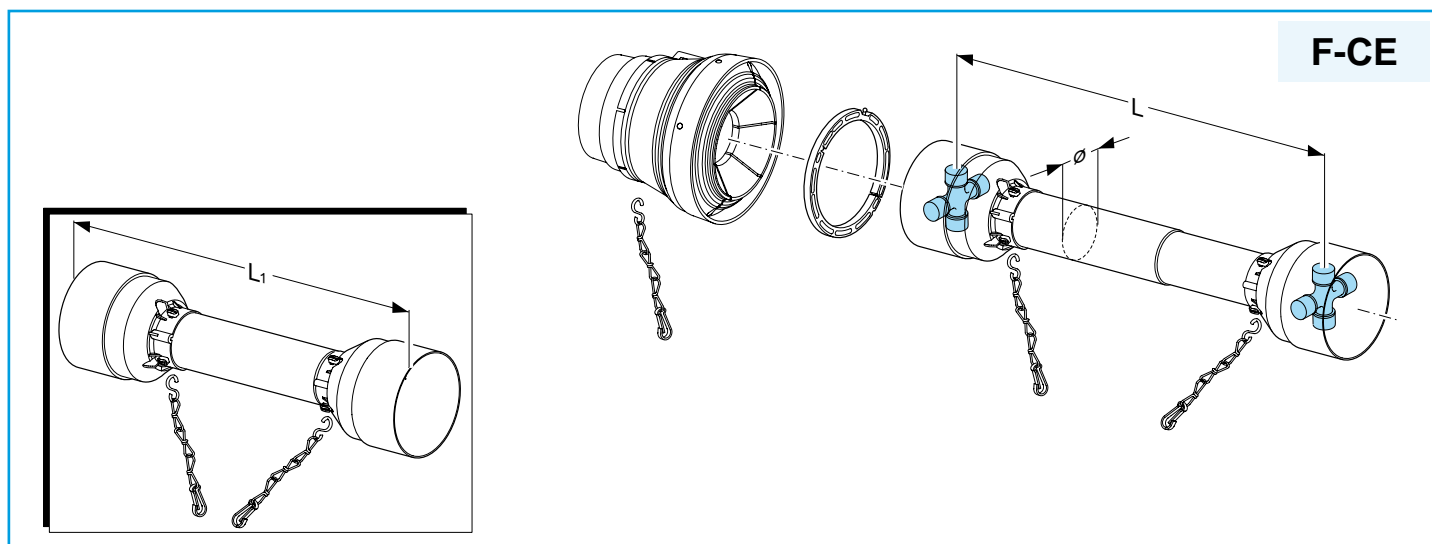
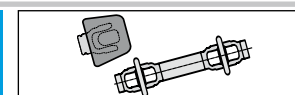

Type	ø = 61 mm 20		ø = 66.5 mm 40		ø = 81.2 mm 60		ø = 96 mm 80	
	L ₁ [mm]	Code	L ₁ [mm]	Code	L ₁ [mm]	Code	L ₁ [mm]	Code
L = 410	405	142.721.008.3231	410	142.741.013.3431	405	142.761.021.3631	415	142.781.009.3831
L = 460	455	142.721.002.3231	460	142.741.014.3431	455	142.761.022.3631	465	142.781.010.3831
L = 510	505	142.721.003.3231	510	142.741.015.3431	505	142.761.023.3631	515	142.781.011.3831
L = 560	555	142.721.004.3231	560	142.741.016.3431	555	142.761.024.3631	565	142.781.012.3831
L = 610	605	142.721.005.3231	610	142.741.017.3431	605	142.761.025.3631	615	142.781.013.3831
L = 660	655	142.721.006.3231	660	142.741.018.3431	655	142.761.001.3631	665	142.781.014.3831
L = 710	705	142.721.007.3231	710	142.741.001.3431	705	142.761.026.3631	715	142.781.015.3831
L = 760	755	142.721.001.3231	760	142.741.008.3431	755	142.761.007.3631	765	142.781.016.3831
L = 810	805	142.721.009.3231	810	142.741.019.3431	805	142.761.027.3631	815	142.781.017.3831
L = 860	855	142.721.010.3231	860	142.741.020.3431	855	142.761.010.3631	865	142.781.018.3831
L = 910	905	142.721.011.3231	910	142.741.004.3431	905	142.761.028.3631	915	142.781.019.3831
L = 1010	1005	142.721.012.3231	1010	142.741.007.3431	1005	142.761.008.3631	1015	142.781.020.3831
L = 1110	1105	142.721.013.3231	1110	142.741.003.3431	1105	142.761.003.3631	1115	142.781.021.3831
L = 1210	1205	142.721.014.3231	1210	142.741.002.3431	1205	142.761.004.3631	1215	142.781.022.3831
L = 1310	1305	142.721.026.3231	1310	142.741.047.3431	1305	142.761.050.3631	1315	142.781.048.3831
L = 1410	1405	142.721.027.3231	1410	142.741.043.3431	1405	142.761.089.3631	1415	142.781.049.3831

Per codifica e tipologia protezione vedere pag.
 For coding and guard typology see pag.

121

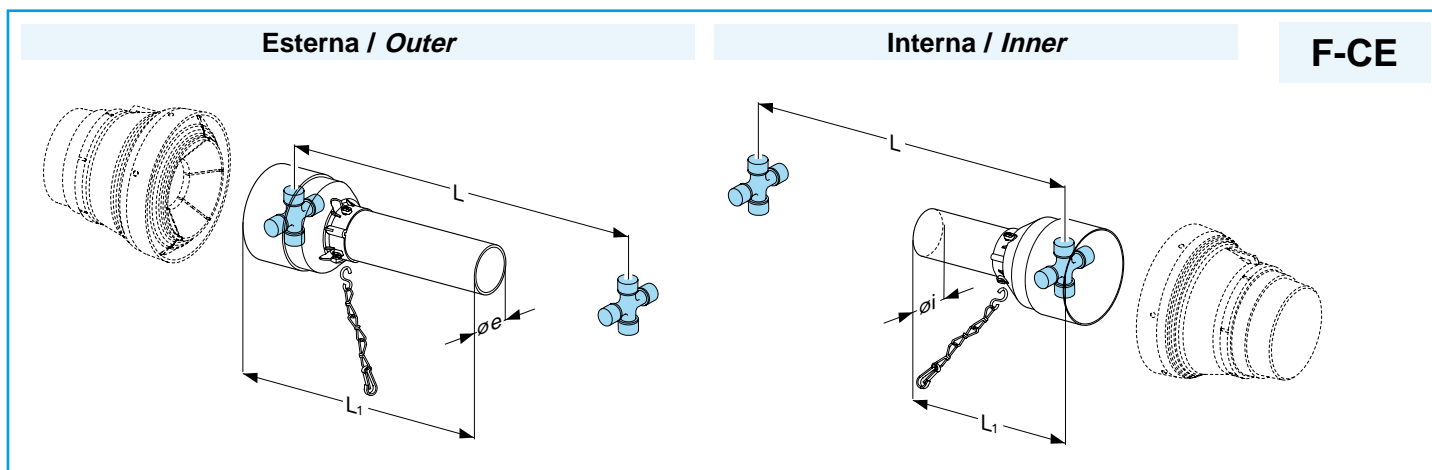
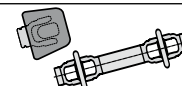

F-CE

Type	$\varnothing_e = 61 \text{ mm}$ 20		$\varnothing_e = 66.5 \text{ mm}$ 40		$\varnothing_e = 81.2 \text{ mm}$ 60		$\varnothing_e = 96 \text{ mm}$ 80		
	L_1 [mm]	Code	L_1 [mm]	Code	L_1 [mm]	Code	L_1 [mm]	Code	
Esterna / Outer	L = 410	265	142.226.016.2231	260	142.246.021.2431	245	142.266.040.2631	225	142.283.036.2831
	L = 460	315	142.226.010.2231	310	142.246.022.2431	295	142.266.041.2631	275	142.283.037.2831
	L = 510	365	142.226.011.2231	360	142.246.017.2431	345	142.266.042.2631	325	142.283.038.2831
	L = 560	415	142.226.012.2231	410	142.246.023.2431	395	142.266.043.2631	375	142.283.039.2831
	L = 610	465	142.226.013.2231	460	142.246.024.2431	445	142.266.044.2631	425	142.283.040.2831
	L = 660	515	142.226.014.2231	510	142.246.025.2431	495	142.261.158.2631	475	142.283.041.2831
	L = 710	565	142.226.015.2231	560	142.241.156.2431	545	142.261.037.2631	525	142.283.042.2831
	L = 760	615	142.221.149.2231	610	142.241.186.2431	595	142.261.177.2631	575	142.283.043.2831
	L = 810	665	142.221.156.2231	660	142.246.026.2431	645	142.261.035.2631	625	142.283.044.2831
	L = 860	715	142.226.017.2231	710	142.246.027.2431	695	142.261.183.2631	675	142.281.187.2831
	L = 910	765	142.226.018.2231	760	142.241.159.2431	745	142.266.045.2631	725	142.283.045.2831
	L = 1010	865	142.221.150.2231	860	142.241.184.2431	845	142.261.182.2631	825	142.283.046.2831
	L = 1110	965	142.226.019.2231	960	142.246.018.2431	945	142.261.185.2631	925	142.283.047.2831
	L = 1210	1065	142.226.020.2231	1060	142.241.185.2431	1045	142.261.034.2631	1025	142.283.048.2831
L = 1310	1165	142.226.046.2231	1160	142.246.084.2431	1145	142.266.048.2631	1125	142.283.126.2831	
L = 1410	1265	142.226.056.2231	1260	142.246.066.2431	1245	142.266.090.2631	1225	142.283.147.2831	

Type	$\varnothing_i = 55.6 \text{ mm}$ 20		$\varnothing_i = 61 \text{ mm}$ 40		$\varnothing_i = 75 \text{ mm}$ 60		$\varnothing_i = 89.9 \text{ mm}$ 80		
	L_1 [mm]	Code	L_1 [mm]	Code	L_1 [mm]	Code	L_1 [mm]	Code	
Interna / Inner	L = 410	265	142.227.044.2231	260	142.247.047.2431	245	142.267.064.2631	225	142.287.055.2831
	L = 460	315	142.227.017.2231	310	142.247.018.2431	295	142.261.299.2631	275	142.281.275.2831
	L = 510	365	142.227.021.2231	360	142.241.269.2431	345	142.267.001.2631	325	142.281.250.2831
	L = 560	415	142.221.232.2231	410	142.241.261.2431	395	142.261.298.2631	375	142.281.247.2831
	L = 610	465	142.227.020.2231	460	142.241.312.2431	445	142.261.267.2631	425	142.281.276.2831
	L = 660	515	142.227.016.2231	510	142.241.287.2431	495	142.261.272.2631	475	142.287.056.2831
	L = 710	565	142.227.022.2231	560	142.241.313.2431	545	142.261.330.2631	525	142.281.258.2831
	L = 760	615	142.227.045.2231	610	142.247.040.2431	595	142.261.289.2631	575	142.287.059.2831
	L = 810	665	142.227.018.2231	660	142.247.041.2431	645	142.261.270.2631	625	142.281.287.2831
	L = 860	715	142.227.046.2231	710	142.247.026.2431	695	142.261.269.2631	675	142.287.061.2831
	L = 910	765	142.227.047.2231	760	142.241.223.2431	745	142.267.028.2631	725	142.281.267.2831
	L = 1010	865	142.221.246.2231	860	142.247.014.2431	845	142.261.280.2631	825	142.287.008.2831
	L = 1110	965	142.227.048.2231	960	142.247.042.2431	945	142.261.334.2631	925	142.281.292.2831
	L = 1210	1065	142.227.049.2231	1060	142.241.250.2431	1045	142.261.286.2631	1025	142.281.286.2831
L = 1310	1165	142.227.035.2231	1160	142.241.271.2431	1145	142.267.043.2631	1125	142.287.052.2831	
L = 1410	1265	142.227.019.2231	1260	142.247.046.2431	1245	142.267.005.2631	1225	142.287.053.2831	

Per codifica e tipologia protezione vedere pag.
For coding and guard tipology see pag.

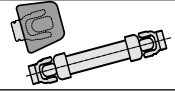

F-CE

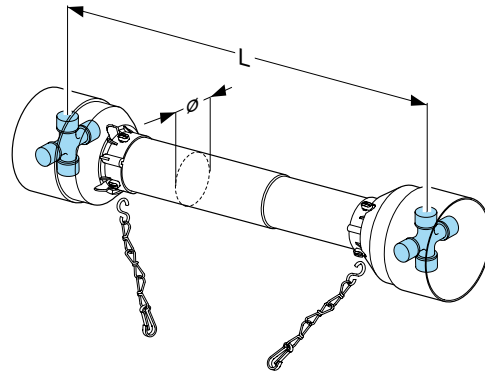
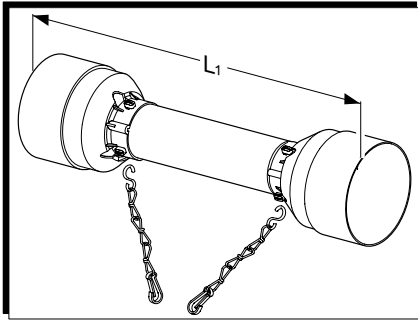

Type	ø = 61 mm 10		ø = 61 mm 20		ø = 66.5 mm 40		ø = 81.2 mm 50	
	L ₁ [mm]	Code	L ₁ [mm]	Code	L ₁ [mm]	Code	L ₁ [mm]	Code
L = 410	470	142.210.206.7131	470	142.220.206.9231	465	142.240.206.9431	470	142.250.206.9531
L = 460	520	142.210.243.7131	520	142.220.264.9231	515	142.240.281.9431	520	142.250.004.9531
L = 510	570	142.210.207.7131	570	142.220.207.9231	565	142.240.207.9431	570	142.250.207.9531
L = 560	620	142.210.233.7131	620	142.220.269.9231	615	142.240.048.9431	620	142.250.264.9531
L = 610	670	142.210.208.7131	670	142.220.208.9231	665	142.240.208.9431	670	142.250.208.9531
L = 660	720	142.210.235.7131	720	142.220.246.9231	715	142.240.286.9431	720	142.250.277.9531
L = 710	770	142.210.209.7131	770	142.220.209.9231	765	142.240.209.9431	770	142.250.209.9531
L = 760	820	142.210.236.7131	820	142.220.247.9231	815	142.240.288.9431	820	142.250.278.9531
L = 810	870	142.210.210.7131	870	142.220.210.9231	865	142.240.210.9431	870	142.250.210.9531
L = 860	920	142.210.237.7131	920	142.220.248.9231	915	142.240.289.9431	920	142.250.279.9531
L = 910	970	142.210.211.7131	970	142.220.211.9231	965	142.240.211.9431	970	142.250.211.9531
L = 1010	1070	142.210.212.7131	1070	142.220.212.9231	1065	142.240.212.9431	1070	142.250.212.9531
L = 1110	1170	142.210.213.7131	1170	142.220.213.9231	1165	142.240.213.9431	1170	142.250.213.9531
L = 1210	1270	142.210.214.7131	1270	142.220.214.9231	1265	142.240.214.9431	1270	142.250.214.9531
L = 1310	1370	142.210.215.7131	1370	142.220.215.9231	1365	142.240.215.9431	1370	142.250.215.9531
L = 1410	1470	142.210.216.7131	1470	142.220.216.9231	1465	142.240.216.9431	1470	142.250.216.9531

Type	ø = 81.2 mm 60		ø = 96 mm 80		ø = 96 mm 90	
	L ₁ [mm]	Code	L ₁ [mm]	Code	L ₁ [mm]	Code
L = 410	465	142.260.302.9631	500	142.286.065.9831	490	142.290.245.9931
L = 460	515	142.260.207.9631	550	142.286.020.9831	540	142.290.207.9931
L = 510	565	142.260.017.9631	600	142.286.089.9831	590	142.290.230.9931
L = 560	615	142.260.208.9631	650	142.286.060.9831	640	142.290.208.9931
L = 610	665	142.260.003.9631	700	142.286.004.9831	690	142.290.216.9931
L = 660	715	142.260.209.9631	750	142.286.005.9831	740	142.290.209.9931
L = 710	765	142.260.004.9631	800	142.286.006.9831	790	142.290.217.9931
L = 760	815	142.260.210.9631	850	142.286.007.9831	840	142.290.210.9931
L = 810	865	142.260.005.9631	900	142.286.008.9831	890	142.290.218.9931
L = 860	915	142.260.211.9631	950	142.286.009.9831	940	142.290.211.9931
L = 910	965	142.260.006.9631	1000	142.286.010.9831	990	142.290.219.9931
L = 1010	1065	142.260.212.9631	1100	142.286.011.9831	1090	142.290.212.9931
L = 1110	1165	142.260.213.9631	1200	142.286.012.9831	1190	142.290.213.9931
L = 1210	1265	142.260.214.9631	1300	142.286.013.9831	1290	142.290.214.9931
L = 1310	1365	142.260.215.9631	1400	142.286.086.9831	1390	142.290.215.9931
L = 1410	1465	142.260.216.9631	1500	142.286.088.9831	1490	142.290.246.9931

Per codifica e tipologia protezione vedere pag.
For coding and guard tipology see pag.

121

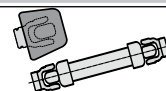

Esterna / Outer

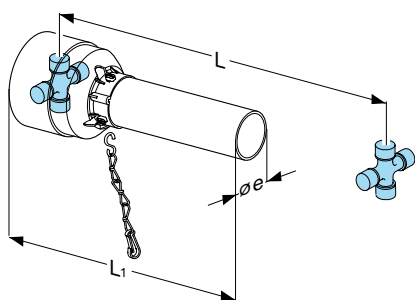

Interna / Inner

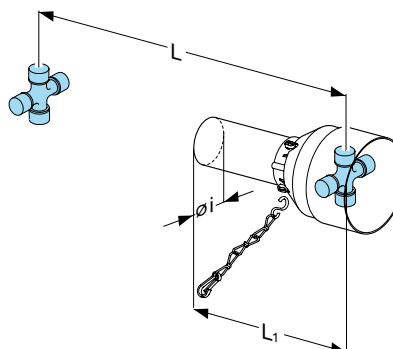

F-CE

Type	ø _e = 61 mm 10		ø _e = 61 mm 20		ø _e = 66.5 mm 40		ø _e = 81.2 mm 50		
	L ₁ [mm]	Code	L ₁ [mm]	Code	L ₁ [mm]	Code	L ₁ [mm]	Code	
Esterna / Outer	L = 410	330	142.211.128.7131	330	142.221.136.9231	315	142.241.155.9431	320	142.256.008.9531
	L = 460	380	142.211.126.7131	380	142.221.152.9231	365	142.241.146.9431	370	142.251.168.9531
	L = 510	430	142.211.134.7131	430	142.221.137.9231	415	142.241.148.9431	420	142.251.144.9531
	L = 560	480	142.211.121.7131	480	142.221.135.9231	465	142.241.175.9431	470	142.251.162.9531
	L = 610	530	142.211.122.7131	530	142.221.139.9231	515	142.241.139.9431	520	142.251.137.9531
	L = 660	580	142.216.007.7131	580	142.221.161.9231	565	142.241.150.9431	570	142.251.174.9531
	L = 710	630	142.211.120.7131	630	142.221.128.9231	615	142.241.140.9431	620	142.251.143.9531
	L = 760	680	142.211.129.7131	680	142.221.162.9231	665	142.241.141.9431	670	142.251.142.9531
	L = 810	730	142.211.123.7131	730	142.221.138.9231	715	142.241.144.9431	720	142.251.146.9531
	L = 860	780	142.216.008.7131	780	142.221.144.9231	765	142.246.012.9431	770	142.251.177.9531
	L = 910	830	142.216.001.7131	830	142.221.147.9231	815	142.241.173.9431	820	142.251.154.9531
	L = 1010	930	142.216.002.7131	930	142.221.127.9231	915	142.241.145.9431	920	142.251.150.9531
	L = 1110	1030	142.211.133.7131	1030	142.221.129.9231	1015	142.241.509.9431	1020	142.256.009.9531
	L = 1210	1130	142.216.003.7131	1130	142.226.001.9231	1115	142.241.149.9431	1120	142.256.010.9531
L = 1310	1230	142.216.004.7131	1230	142.221.148.9231	1215	142.241.192.9431	1220	142.256.011.9531	
L = 1410	1330	142.216.005.7131	1330	142.226.002.9231	1315	142.246.009.9431	1320	142.251.176.9531	

Type	ø _i = 55.6 mm 10		ø _i = 55.6 mm 20		ø _i = 61 mm 40		ø _i = 75 mm 50		
	L ₁ [mm]	Code	L ₁ [mm]	Code	L ₁ [mm]	Code	L ₁ [mm]	Code	
Interna / Inner	L = 410	330	142.211.222.7131	330	142.221.233.9231	315	142.241.252.9431	305	142.257.007.9531
	L = 460	380	142.211.220.7131	380	142.221.247.9231	365	142.241.247.9431	355	142.251.264.9531
	L = 510	430	142.211.219.7131	430	142.221.234.9231	415	142.241.254.9431	405	142.251.242.9531
	L = 560	480	142.211.216.7131	480	142.221.231.9231	465	142.241.253.9431	455	142.251.249.9531
	L = 610	530	142.211.217.7131	530	142.221.235.9231	515	142.241.237.9431	505	142.251.235.9531
	L = 660	580	142.211.224.7131	580	142.221.257.9231	565	142.241.251.9431	565	142.257.016.9531
	L = 710	630	142.211.215.7131	630	142.221.226.9231	615	142.241.241.9431	605	142.251.248.9531
	L = 760	680	142.211.221.7131	680	142.221.242.9231	665	142.241.242.9431	665	142.251.240.9531
	L = 810	730	142.211.218.7131	730	142.221.228.9231	715	142.241.245.9431	705	142.251.244.9531
	L = 860	780	142.217.007.7131	780	142.221.240.9231	765	142.241.274.9431	765	142.251.253.9531
	L = 910	830	142.217.001.7131	830	142.221.244.9231	815	142.241.256.9431	805	142.251.250.9531
	L = 1010	930	142.217.002.7131	930	142.221.225.9231	915	142.241.246.9431	905	142.251.255.9531
	L = 1110	1030	142.211.225.7131	1030	142.221.227.9231	1015	142.241.301.9431	1005	142.257.008.9531
	L = 1210	1130	142.217.003.7131	1130	142.221.251.9231	1115	142.241.243.9431	1105	142.251.274.9531
L = 1310	1230	142.217.004.7131	1230	142.221.245.9231	1215	142.241.288.9431	1205	142.257.009.9531	
L = 1410	1330	142.217.005.7131	1330	142.227.001.9231	1315	142.247.015.9431	1305	142.257.010.9531	

Per codifica e tipologia protezione vedere pag.
For coding and guard tipology see pag.

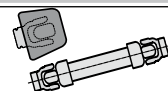

Esterna / Outer

Interna / Inner

F-CE

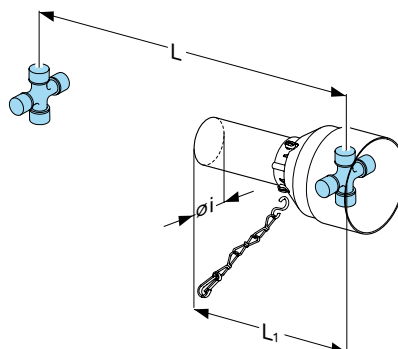
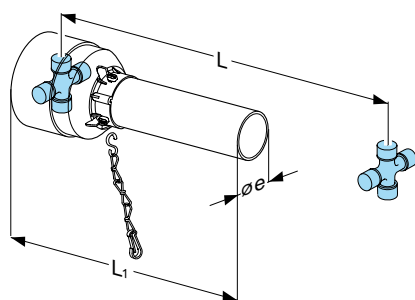

Type	$\varnothing_e = 81.2 \text{ mm}$ 60		$\varnothing_e = 96 \text{ mm}$ 80		$\varnothing_e = 96 \text{ mm}$ 90	
	L ₁ [mm]	Code	L ₁ [mm]	Code	L ₁ [mm]	Code
L = 410	305	142.266.050.9631	305	142.283.028.9831	295	142.296.026.9931
L = 460	355	142.261.004.9631	355	142.281.171.9831	345	142.296.001.9931
L = 510	405	142.261.188.9631	405	142.281.141.9831	395	142.296.017.9931
L = 560	455	142.261.141.9631	455	142.281.138.9831	445	142.296.002.9931
L = 610	505	142.261.154.9631	505	142.281.170.9831	495	142.291.102.9931
L = 660	555	142.261.199.9631	555	142.281.155.9831	545	142.296.003.9931
L = 710	605	142.261.006.9631	605	142.281.181.9831	595	142.296.009.9931
L = 760	655	142.261.152.9631	655	142.281.169.9831	645	142.296.004.9931
L = 810	705	142.261.171.9631	705	142.281.174.9831	695	142.296.010.9931
L = 860	755	142.261.170.9631	755	142.281.154.9831	745	142.291.101.9931
L = 910	805	142.261.148.9631	805	142.281.144.9831	795	142.296.011.9931
L = 1010	905	142.261.147.9631	905	142.283.004.9831	895	142.296.005.9931
L = 1110	1005	142.261.039.9631	1005	142.281.189.9831	995	142.296.006.9931
L = 1210	1105	142.261.156.9631	1105	142.281.157.9831	1095	142.296.007.9931
L = 1310	1205	142.261.190.9631	1205	142.283.001.9831	1195	142.296.008.9931
L = 1410	1305	142.266.027.9631	1305	142.283.059.9831	1295	142.296.027.9931

Type	$\varnothing_i = 75 \text{ mm}$ 60		$\varnothing_i = 89.9 \text{ mm}$ 80		$\varnothing_i = 89.9 \text{ mm}$ 90	
	L ₁ [mm]	Code	L ₁ [mm]	Code	L ₁ [mm]	Code
L = 410	300	142.267.040.9631	305	142.287.029.9831	295	142.297.027.9931
L = 460	350	142.261.315.9631	355	142.287.007.9831	345	142.297.001.9931
L = 510	400	142.261.284.9631	405	142.287.036.9831	395	142.297.015.9931
L = 560	450	142.261.238.9631	455	142.281.285.9831	445	142.297.002.9931
L = 610	500	142.261.262.9631	505	142.281.271.9831	495	142.297.009.9931
L = 660	550	142.261.256.9631	555	142.281.262.9831	545	142.297.003.9931
L = 710	600	142.261.266.9631	605	142.287.003.9831	595	142.297.010.9931
L = 760	650	142.261.250.9631	655	142.281.272.9831	645	142.297.004.9931
L = 810	700	142.261.275.9631	705	142.281.265.9831	695	142.291.203.9931
L = 860	750	142.261.268.9631	755	142.281.257.9831	745	142.291.201.9931
L = 910	800	142.261.246.9631	805	142.281.253.9831	795	142.297.011.9931
L = 1010	900	142.261.274.9631	905	142.287.004.9831	895	142.297.005.9931
L = 1110	1000	142.261.281.9631	1005	142.287.005.9831	995	142.297.006.9931
L = 1210	1100	142.261.213.9631	1105	142.281.264.9831	1095	142.297.007.9931
L = 1310	1200	142.261.285.9631	1205	142.287.001.9831	1195	142.297.008.9931
L = 1410	1300	142.267.025.9631	1305	142.287.043.9831	1295	142.297.028.9931

Per codifica e tipologia protezione vedere pag.
For coding and guard tipology see pag.

121

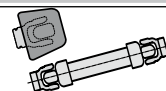

Cuffia esterna / Outer Cone

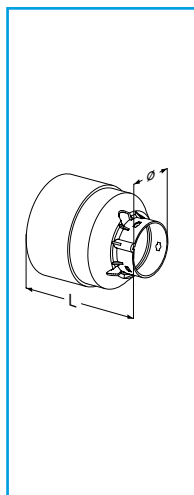

Version	10		20		40		50		60		80		90	
	L [mm]	Code	L [mm]	Code	L [mm]	Code	L [mm]	Code	L [mm]	Code	L [mm]	Code	L [mm]	Code
CE	Short	76 158.032.198	76 158.032.198	94 158.034.411	104 180.036.435	104 180.036.435	108 180.038.259	108 180.038.126						
	Standard	140 180.032.182	140 180.032.182	149 180.034.237	165 180.036.234	165 180.036.024	192 180.038.253	192 180.038.253						
	Long	210 180.031.387	210 180.031.387	234 180.034.622	274 180.036.796	274 180.036.796	-	-						
L	Short	76 158.022.198	76 158.022.198	94 158.024.411	104 180.026.435	104 180.026.435	108 180.028.259	108 180.028.259						
	Standard	140 180.022.182	140 180.022.182	149 180.024.237	165 180.026.234	165 180.026.234	192 180.028.253	192 180.029.253						
	Long	210 180.022.517	210 180.022.517	234 180.024.384	274 180.025.430	274 180.025.430	-	-						

Cuffia interna / Inner Cone

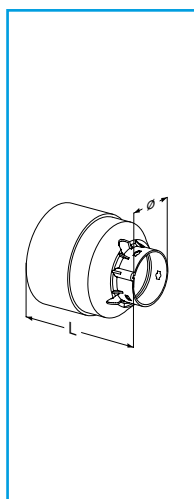

Version	10		20		40		50		60		80		90	
	L [mm]	Code	L [mm]	Code	L [mm]	Code	L [mm]	Code	L [mm]	Code	L [mm]	Code	L [mm]	Code
CE	Short	76 158.032.429	76 158.032.429	94 180.034.383	104 180.036.242	104 180.036.242	108 180.038.260	108 180.038.260						
	Standard	140 180.032.181	140 180.032.181	149 180.034.234	151 180.035.359	159 180.036.239	192 180.038.254	192 180.038.254						
	Long	210 180.031.384	210 180.031.384	234 180.034.298	274 180.036.436	274 180.036.436	-	-						
L	Short	76 158.022.429	76 158.022.429	94 180.024.383	104 180.026.242	104 180.026.242	108 180.028.260	108 180.028.260						
	Standard	140 180.022.181	140 180.022.181	149 180.024.234	151 180.025.359	159 180.026.239	192 180.028.254	192 180.028.254						
	Long	210 180.021.268	210 180.021.268	234 180.024.610	274 180.026.669	274 180.026.669	-	-						

Ghiera / Retaining Collar

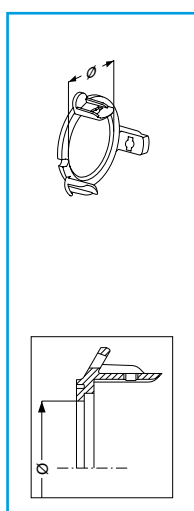

Version	10	20	40	50	60	80	90
	ø = 40 mm Code	ø = 46 mm Code	ø = 54 mm Code	ø = 62.5 mm Code	ø = 69 mm Code	ø = 81.5 mm Code	ø = 81.5 mm Code
Esterna Outer	180.011.242	180.012.184	180.014.233	180.015.288	180.016.237	180.019.251	180.019.251
Version	10	20	40	50	60	80	90
	ø = 34 mm Code	ø = 40 mm Code	ø = 47 mm Code	ø = 54.5 mm Code	ø = 60 mm Code	ø = 69.5 mm Code	ø = 69.5 mm Code
Interna Inner	180.011.241	180.012.183	180.014.232	180.015.289	180.016.238	180.019.252	180.019.252

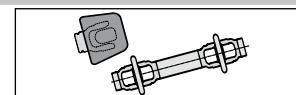

Cuffia / Cone

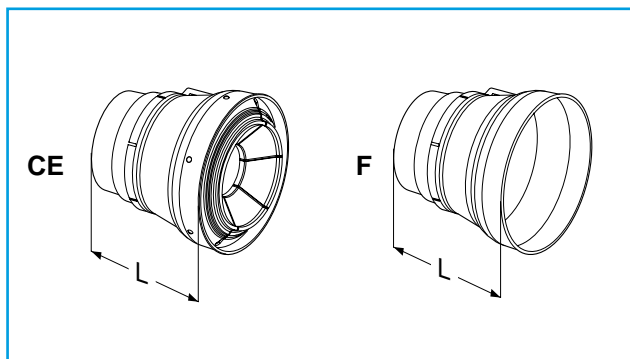

Versione Version	20		40		60		80	
	L [mm]	Code	L [mm]	Code	L [mm]	Code	L [mm]	Code
CE	192	180.022.199	235	180.026.439	235	180.026.439	248	180.028.265
F	192	180.012.199	235	180.016.439	235	180.016.439	248	180.018.265

Ghiera / Retaining Collar

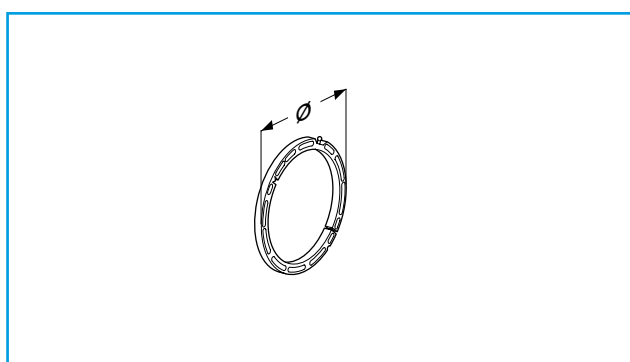

Versione Version	20		40		60		80	
	Ø [mm]	Code	Ø [mm]	Code	Ø [mm]	Code	Ø [mm]	Code
F-CE	171	180.012.200	187	180.016.440	187	180.016.440	210	180.018.264

kit cuffia / Guard cone set

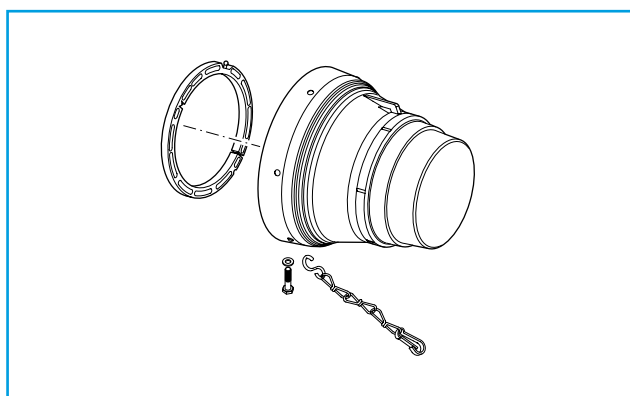

Versione Version	20	40	60	80
	Code	Code	Code	Code
CE	165.000.673	165.000.674	165.000.674	165.000.675
F	165.000.670	165.000.671	165.000.671	165.000.672

Catenella di sicurezza / Safety Chain

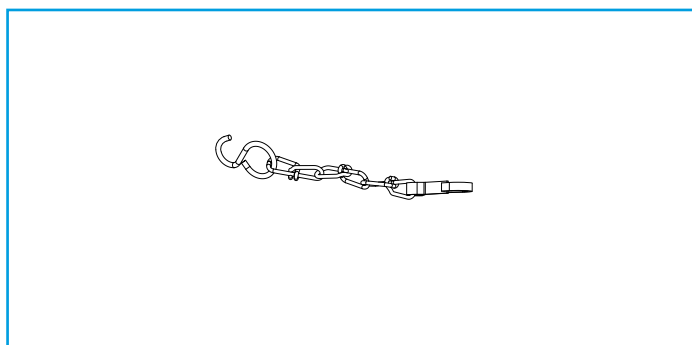

Code 180.016.790

Vite di bloccaggio / Bolt

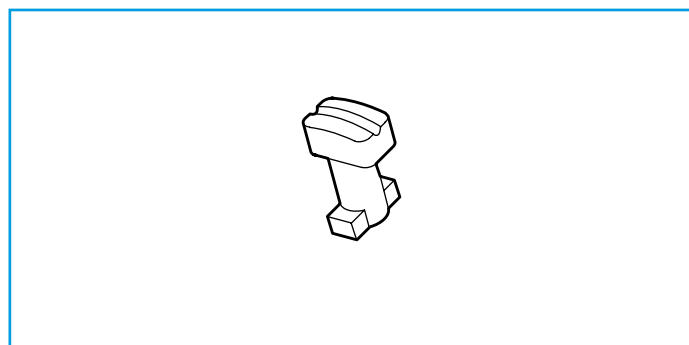

Code 180.014.240

PROTEZIONI COMPLETE DOPPIO CVJ - SERIE V
COMPLETE GUARDS DOUBLE CVJ - SERIE V

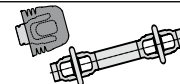

N-EN

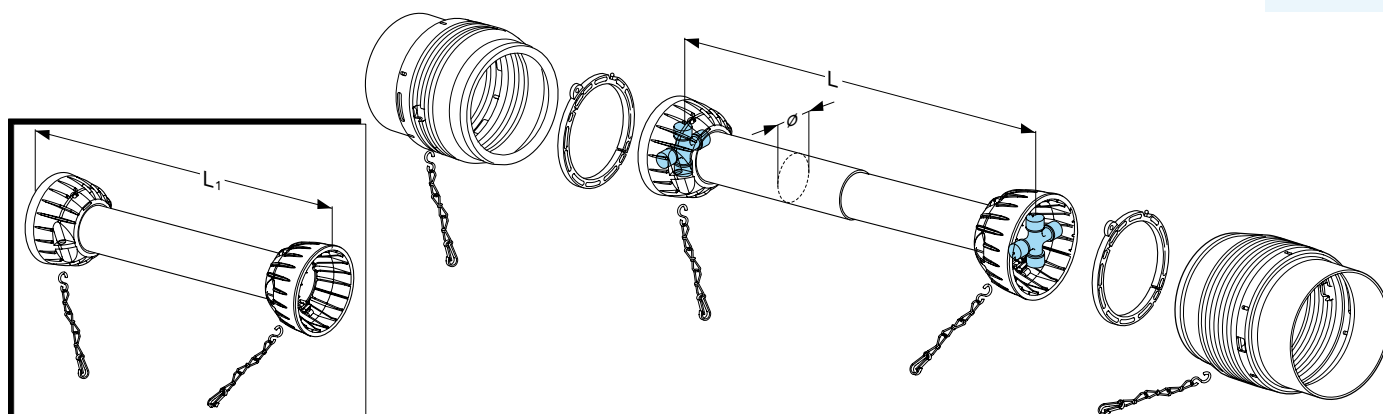

Type	ø = 61 mm 20		ø = 66.5 mm 40		ø = 81.2 mm 60		ø = 96 mm 80	
	L ₁ [mm]	Code	L ₁ [mm]	Code	L ₁ [mm]	Code	L ₁ [mm]	Code
L = 410	338	142.922.506.2251	343	142.942.506.2451	344	142.962.501.2651	336	142.982.501.2851
L = 460	388	142.922.501.2251	393	142.942.501.2451	394	142.962.507.2651	386	142.982.507.2851
L = 510	438	142.922.507.2251	443	142.942.507.2451	444	142.962.502.2651	436	142.982.502.2851
L = 560	488	142.922.502.2251	493	142.942.502.2451	494	142.962.508.2651	486	142.982.508.2851
L = 610	538	142.922.508.2251	543	142.942.508.2451	544	142.962.503.2651	536	142.982.503.2851
L = 660	588	142.922.503.2251	593	142.942.503.2451	594	142.962.509.2651	586	142.982.509.2851
L = 710	638	142.922.509.2251	643	142.942.509.2451	644	142.962.504.2651	636	142.982.504.2851
L = 760	688	142.922.504.2251	693	142.942.504.2451	694	142.962.510.2651	686	142.982.510.2851
L = 810	738	142.922.510.2251	743	142.942.510.2451	744	142.962.505.2651	736	142.982.505.2851
L = 860	788	142.922.505.2251	793	142.942.505.2451	794	142.962.511.2651	786	142.982.511.2851
L = 910	838	142.922.511.2251	843	142.942.511.2451	844	142.962.517.2651	836	142.982.517.2851
L = 1010	938	142.922.512.2251	943	142.942.512.2451	944	142.962.512.2651	936	142.982.512.2851
L = 1110	1038	142.922.513.2251	1043	142.942.513.2451	1044	142.962.513.2651	1036	142.982.513.2851
L = 1210	1138	142.922.514.2251	1143	142.942.514.2451	1144	142.962.514.2651	1136	142.982.514.2851
L = 1310	1238	142.922.515.2251	1243	142.942.515.2451	1244	142.962.515.2651	1236	142.982.515.2851
L = 1410	1388	142.922.516.2251	1343	142.942.516.2451	1344	142.962.516.2651	1336	142.982.516.2851

Per codifica e tipologia protezione vedere pag.
 For coding and guard typology see pag.

121

PROTEZIONI COMPLETE SINGOLO CVJ - SERIE V
COMPLETE GUARDS SINGLE CVJ - SERIE V

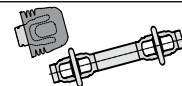

N-EN

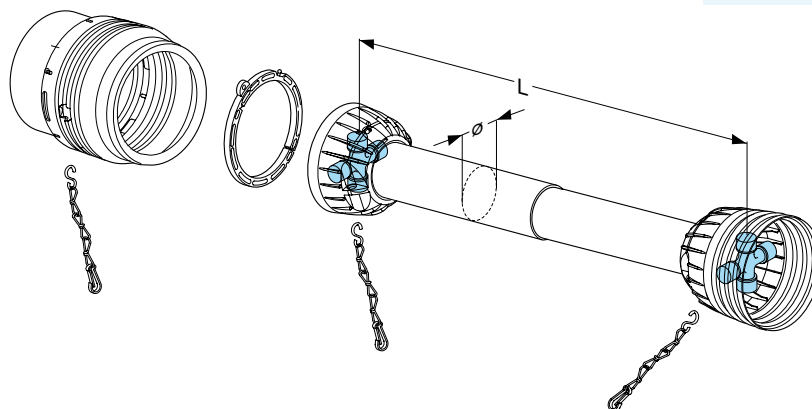
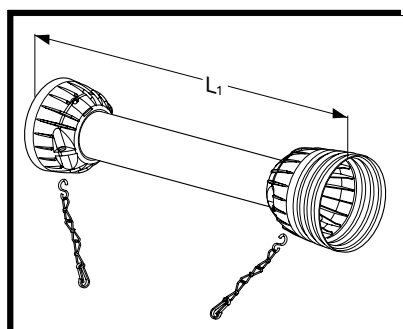

Type	ø = 61 mm 20		ø = 66.5 mm 40		ø = 81.2 mm 60		ø = 96 mm 80	
	L ₁ [mm]	Code	L ₁ [mm]	Code	L ₁ [mm]	Code	L ₁ [mm]	Code
L = 410	396	142.921.506.2251	397	142.941.506.2451	405	142.961.501.2651	413	142.981.501.2851
L = 460	446	142.921.501.2251	447	142.941.501.2451	455	142.961.507.2651	463	142.981.507.2851
L = 510	496	142.921.507.2251	497	142.941.507.2451	505	142.961.502.2651	513	142.981.502.2851
L = 560	546	142.921.502.2251	547	142.941.502.2451	555	142.961.508.2651	563	142.981.508.2851
L = 610	596	142.921.508.2251	597	142.941.508.2451	605	142.961.503.2651	613	142.981.503.2851
L = 660	646	142.921.503.2251	647	142.941.503.2451	655	142.961.509.2651	663	142.981.509.2851
L = 710	696	142.921.509.2251	697	142.941.509.2451	705	142.961.504.2651	713	142.981.504.2851
L = 760	746	142.921.504.2251	747	142.941.504.2451	755	142.961.510.2651	763	142.981.510.2851
L = 810	796	142.921.510.2251	797	142.941.510.2451	805	142.961.505.2651	813	142.981.505.2851
L = 860	846	142.921.505.2251	847	142.941.505.2451	855	142.961.511.2651	863	142.981.511.2851
L = 910	896	142.921.511.2251	897	142.941.511.2451	905	142.961.517.2651	913	142.981.517.2851
L = 1010	996	142.921.512.2251	997	142.941.512.2451	1005	142.961.512.2651	1013	142.981.512.2851
L = 1110	1096	142.921.513.2251	1097	142.941.513.2451	1105	142.961.513.2651	1113	142.981.513.2851
L = 1210	1196	142.921.514.2251	1197	142.941.514.2451	1205	142.961.514.2651	1213	142.981.514.2851
L = 1310	1296	142.921.515.2251	1297	142.941.515.2451	1305	142.961.515.2651	1313	142.981.515.2851
L = 1410	1396	142.921.516.2251	1397	142.941.516.2451	1405	142.961.516.2651	1413	142.981.516.2851

Per codifica e tipologia protezione vedere pag.
 For coding and guard typology see pag.

121

PROTEZIONI COMPLETE DOPPIO CVJ - SERIE T
COMPLETE GUARDS DOUBLE CVJ - SERIE T

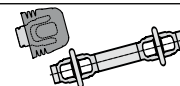

N-EN

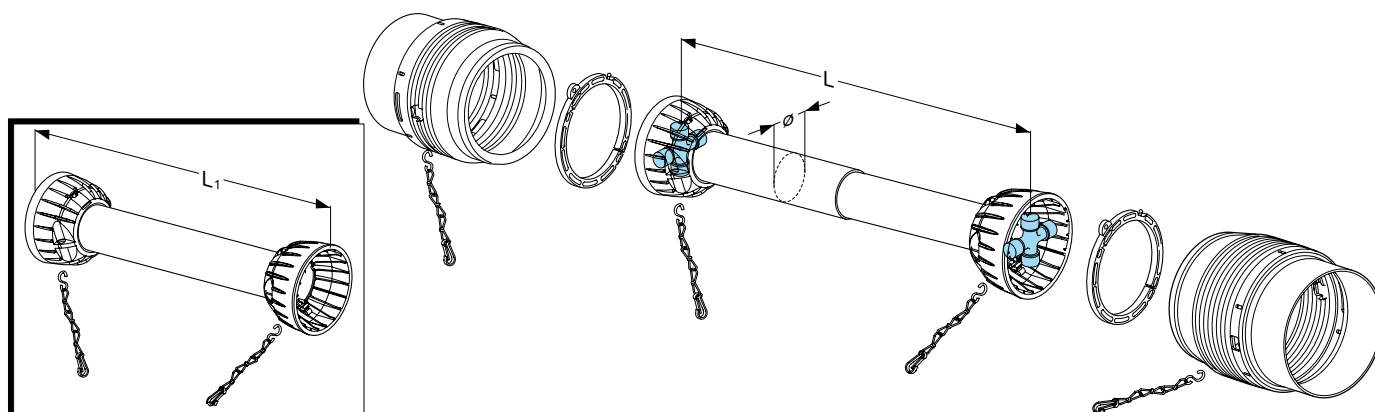

Type	ø = 61 mm 20		ø = 66.5 mm 40		ø = 81.2 mm 60		ø = 96 mm 80	
	L ₁ [mm]	Code	L ₁ [mm]	Code	L ₁ [mm]	Code	L ₁ [mm]	Code
L = 410	338	142.722.506.3251	343	142.742.506.3451	344	142.762.501.3651	336	142.782.501.3851
L = 460	388	142.722.501.3251	393	142.742.501.3451	394	142.762.507.3651	386	142.782.507.3851
L = 510	438	142.722.507.3251	443	142.742.507.3451	444	142.762.502.3651	436	142.782.502.3851
L = 560	488	142.722.502.3251	493	142.742.502.3451	494	142.762.508.3651	486	142.782.508.3851
L = 610	538	142.722.508.3251	543	142.742.508.3451	544	142.762.503.3651	536	142.782.503.3851
L = 660	588	142.722.503.3251	593	142.742.503.3451	594	142.762.509.3651	586	142.782.509.3851
L = 710	638	142.722.509.3251	643	142.742.509.3451	644	142.762.504.3651	636	142.782.504.3851
L = 760	688	142.722.504.3251	693	142.742.504.3451	694	142.762.510.3651	686	142.782.510.3851
L = 810	738	142.722.510.3251	743	142.742.510.3451	744	142.762.505.3651	736	142.782.505.3851
L = 860	788	142.722.505.3251	793	142.742.505.3451	794	142.762.511.3651	786	142.782.511.3851
L = 910	838	142.722.511.3251	843	142.742.511.3451	844	142.762.517.3651	836	142.782.517.3851
L = 1010	938	142.722.512.3251	943	142.742.512.3451	944	142.762.512.3651	936	142.782.512.3851
L = 1110	1038	142.722.513.3251	1043	142.742.513.3451	1044	142.762.513.3651	1036	142.782.513.3851
L = 1210	1138	142.722.514.3251	1143	142.742.514.3451	1144	142.762.514.3651	1136	142.782.514.3851
L = 1310	1238	142.722.515.3251	1243	142.742.515.3451	1244	142.762.515.3651	1236	142.782.515.3851
L = 1410	1338	142.722.516.3251	1343	142.742.516.3451	1344	142.762.516.3651	1336	142.782.516.3851

Per codifica e tipologia protezione vedere pag.
 For coding and guard tipology see pag.

121

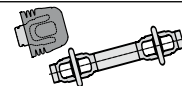

N-EN

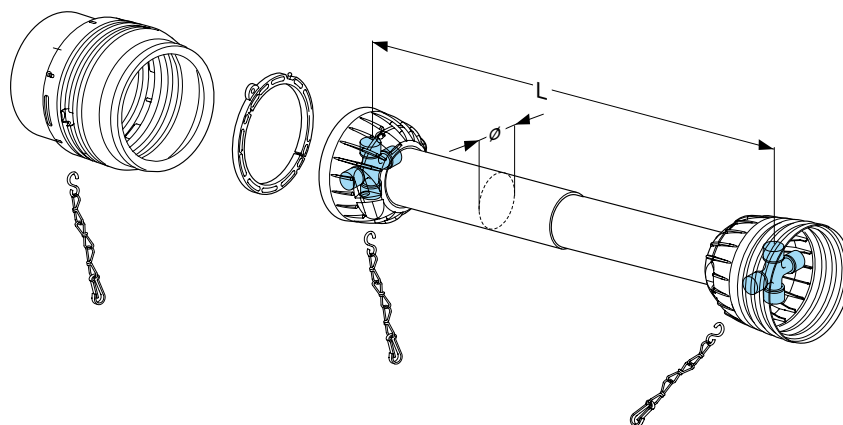
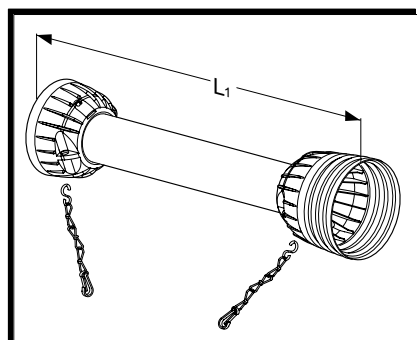

Type	ø = 61 mm 20		ø = 66.5 mm 40		ø = 81.2 mm 60		ø = 96 mm 80	
	L ₁ [mm]	Code	L ₁ [mm]	Code	L ₁ [mm]	Code	L ₁ [mm]	Code
L = 410	396	142.721.506.3251	397	142.741.506.3451	405	142.761.509.3651	413	142.781.501.3851
L = 460	446	142.721.501.3251	447	142.741.501.3451	455	142.761.510.3651	463	142.781.507.3851
L = 510	496	142.721.507.3251	497	142.741.507.3451	505	142.761.511.3651	513	142.781.502.3851
L = 560	546	142.721.502.3251	547	142.741.502.3451	555	142.761.501.3651	563	142.781.508.3851
L = 610	596	142.721.508.3251	597	142.741.508.3451	605	142.761.507.3651	613	142.781.503.3851
L = 660	646	142.721.503.3251	647	142.741.503.3451	655	142.761.505.3651	663	142.781.509.3851
L = 710	696	142.721.509.3251	697	142.741.509.3451	705	142.761.502.3651	713	142.781.504.3851
L = 760	746	142.721.504.3251	747	142.741.504.3451	755	142.761.512.3651	763	142.781.510.3851
L = 810	796	142.721.510.3251	797	142.741.510.3451	805	142.761.504.3651	813	142.781.505.3851
L = 860	846	142.721.505.3251	847	142.741.505.3451	855	142.761.500.3651	863	142.781.511.3851
L = 910	896	142.721.511.3251	897	142.741.511.3451	905	142.761.513.3651	913	142.781.517.3851
L = 1010	996	142.721.512.3251	997	142.741.512.3451	1005	142.761.514.3651	1013	142.781.512.3851
L = 1110	1096	142.721.513.3251	1097	142.741.513.3451	1105	142.761.515.3651	1113	142.781.513.3851
L = 1210	1196	142.721.514.3251	1197	142.741.514.3451	1205	142.761.516.3651	1213	142.781.514.3851
L = 1310	1296	142.721.515.3251	1297	142.741.515.3451	1305	142.761.517.3651	1313	142.781.515.3851
L = 1410	1396	142.721.516.3251	1397	142.741.516.3451	1405	142.761.518.3651	1413	142.781.516.3851

Per codifica e tipologia protezione vedere pag.
 For coding and guard typology see pag.

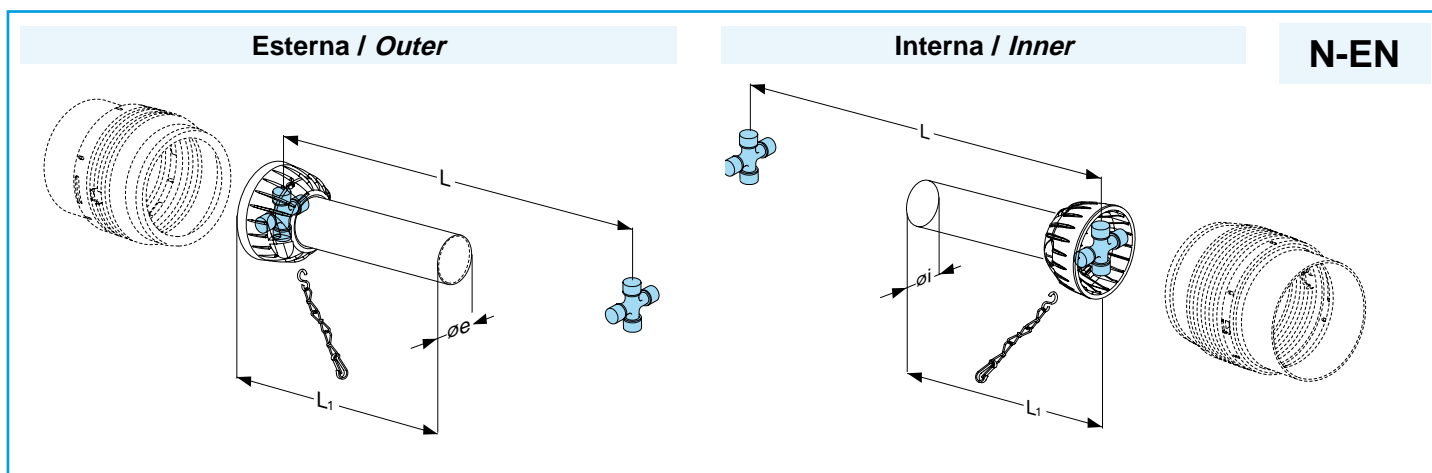
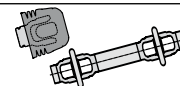

Type	ø _e = 61 mm 20		ø _e = 66.5 mm 40		ø _e = 81.2 mm 60		ø _e = 96 mm 80		
	L ₁ [mm]	Code	L ₁ [mm]	Code	L ₁ [mm]	Code	L ₁ [mm]	Code	
Esterna / Outer	L = 410	269	142.326.019.2251	259	142.346.019.2451	252	142.366.017.2651	233	142.386.019.2851
	L = 460	319	142.326.020.2251	309	142.346.020.2451	302	142.366.023.2651	283	142.386.025.2851
	L = 510	369	142.326.021.2251	359	142.346.021.2451	352	142.366.018.2651	333	142.386.020.2851
	L = 560	419	142.326.022.2251	409	142.346.022.2451	402	142.366.024.2651	383	142.386.026.2851
	L = 610	469	142.326.023.2251	459	142.346.023.2451	452	142.366.019.2651	433	142.386.021.2851
	L = 660	519	142.326.024.2251	509	142.346.024.2451	502	142.366.025.2651	483	142.386.027.2851
	L = 710	569	142.326.025.2251	559	142.346.025.2451	552	142.366.020.2651	533	142.386.022.2851
	L = 760	619	142.326.026.2251	609	142.346.026.2451	602	142.366.026.2651	583	142.386.028.2851
	L = 810	669	142.326.027.2251	659	142.346.027.2451	652	142.366.021.2651	633	142.386.023.2851
	L = 860	719	142.326.028.2251	709	142.346.028.2451	702	142.366.027.2651	683	142.386.029.2851
	L = 910	769	142.326.029.2251	759	142.346.029.2451	752	142.366.034.9651	733	142.386.035.2851
	L = 1010	869	142.326.030.2251	859	142.346.030.2451	852	142.366.028.2651	833	142.386.030.2851
	L = 1110	969	142.326.031.2251	959	142.346.031.2451	952	142.366.029.2651	933	142.386.031.2851
	L = 1210	1069	142.326.032.2251	1059	142.346.032.2451	1052	142.366.030.2651	1033	142.386.032.2851
	L = 1310	1169	142.326.033.2251	1159	142.346.033.2451	1152	142.366.031.2651	1133	142.386.033.2851
L = 1410	1269	142.326.034.2251	1259	142.346.034.2451	1252	142.366.032.2651	1233	142.386.034.2851	

Type	ø _i = 55.6 mm 20		ø _i = 61 mm 40		ø _i = 75 mm 60		ø _i = 89.9 mm 80		
	L ₁ [mm]	Code	L ₁ [mm]	Code	L ₁ [mm]	Code	L ₁ [mm]	Code	
Interna / Inner	L = 410	269	142.327.019.2251	259	142.347.019.2451	252	142.367.017.2651	233	142.387.019.2851
	L = 460	319	142.327.020.2251	309	142.347.020.2451	302	142.367.023.2651	283	142.387.025.2851
	L = 510	369	142.327.021.2251	359	142.347.021.2451	352	142.367.018.2651	333	142.387.020.2851
	L = 560	419	142.327.022.2251	409	142.347.022.2451	402	142.367.024.2651	383	142.387.026.2851
	L = 610	469	142.327.023.2251	459	142.347.023.2451	452	142.367.019.2651	433	142.387.021.2851
	L = 660	519	142.327.024.2251	509	142.347.024.2451	502	142.367.025.2651	483	142.387.027.2851
	L = 710	569	142.327.025.2251	559	142.347.025.2451	552	142.367.020.2651	533	142.387.022.2851
	L = 760	619	142.327.026.2251	609	142.347.026.2451	602	142.367.026.2651	583	142.387.028.2851
	L = 810	669	142.327.027.2251	659	142.347.027.2451	652	142.367.021.2651	633	142.387.023.2851
	L = 860	719	142.327.028.2251	709	142.347.028.2451	702	142.367.027.2651	683	142.387.029.2851
	L = 910	769	142.327.029.2251	759	142.347.029.2451	752	142.367.034.9651	733	142.387.035.2851
	L = 1010	869	142.327.030.2251	859	142.347.030.2451	852	142.367.028.2651	833	142.387.030.2851
	L = 1110	969	142.327.031.2251	959	142.347.031.2451	952	142.367.029.2651	933	142.387.031.2851
	L = 1210	1069	142.327.032.2251	1059	142.347.032.2451	1052	142.367.030.2651	1033	142.387.032.2851
	L = 1310	1169	142.327.033.2251	1159	142.347.033.2451	1152	142.367.031.2651	1133	142.387.033.2851
L = 1410	1269	142.327.034.2251	1259	142.347.034.2451	1252	142.367.032.2651	1233	142.387.034.2851	

Per codifica e tipologia protezione vedere pag.
For coding and guard tipology see pag.

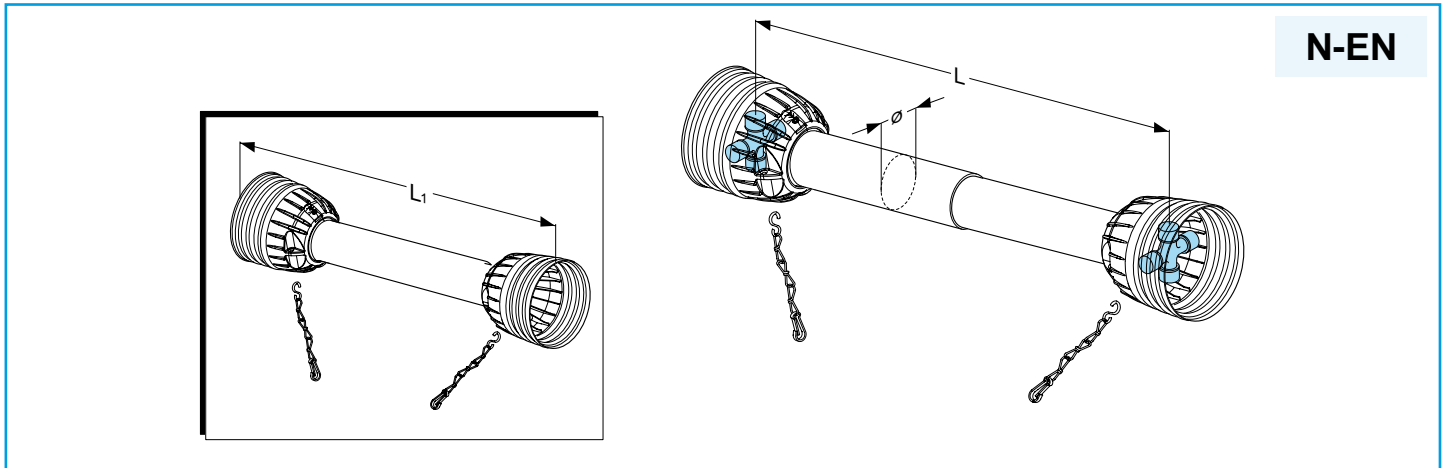
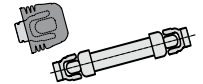

Type	ø = 61 mm 10		ø = 61 mm 20		ø = 66.5 mm 40		ø = 81.2 mm 50	
	L ₁ [mm]	Code	L ₁ [mm]	Code	L ₁ [mm]	Code	L ₁ [mm]	Code
L = 410	454	142.310.006.7151	454	142.320.006.9251	451	142.340.006.9451	476	142.350.006.9551
L = 460	504	142.310.001.7151	504	142.320.001.9251	501	142.340.001.9451	526	142.350.001.9551
L = 510	554	142.310.007.7151	554	142.320.007.9251	551	142.340.007.9451	576	142.350.007.9551
L = 560	604	142.310.002.7151	604	142.320.002.9251	601	142.340.002.9451	626	142.350.002.9551
L = 610	654	142.310.008.7151	654	142.320.008.9251	651	142.340.008.9451	676	142.350.008.9551
L = 660	704	142.310.003.7151	704	142.320.003.9251	701	142.340.003.9451	726	142.350.003.9551
L = 710	754	142.310.009.7151	754	142.320.009.9251	751	142.340.009.9451	776	142.350.009.9551
L = 760	804	142.310.004.7151	804	142.320.004.9251	801	142.340.004.9451	826	142.350.004.9551
L = 810	854	142.310.010.7151	854	142.320.010.9251	851	142.340.010.9451	876	142.350.010.9551
L = 860	904	142.310.005.7151	904	142.320.005.9251	901	142.340.005.9451	926	142.350.005.9551
L = 910	954	142.310.011.7151	954	142.320.011.9251	951	142.340.011.9451	976	142.350.011.9551
L = 1010	1054	142.310.012.7151	1054	142.320.012.9251	1051	142.340.012.9451	1076	142.350.012.9551
L = 1110	1154	142.310.013.7151	1154	142.320.013.9251	1151	142.340.013.9451	1176	142.350.013.9551
L = 1210	1254	142.310.014.7151	1254	142.320.014.9251	1251	142.340.014.9451	1276	142.350.014.9551
L = 1310	1354	142.310.015.7151	1354	142.320.015.9251	1351	142.340.015.9451	1376	142.350.015.9551
L = 1410	1454	142.310.016.7151	1454	142.320.016.9251	1451	142.340.016.9451	1476	142.350.016.9551

Type	ø = 81.2 mm 60		ø = 96 mm 80		ø = 96 mm 90		ø = 96 mm 120	
	L ₁ [mm]	Code	L ₁ [mm]	Code	L ₁ [mm]	Code	L ₁ [mm]	Code
L = 410	466	142.360.001.9651	490	142.380.001.9851	475	142.390.001.9951	-	--
L = 460	516	142.360.007.9651	540	142.380.007.9851	525	142.390.007.9951	545	142.300.001.1251
L = 510	566	142.360.002.9651	590	142.380.002.9851	575	142.390.002.9951	595	142.300.002.1251
L = 560	616	142.360.008.9651	640	142.380.008.9851	625	142.390.008.9951	645	142.300.003.1251
L = 610	666	142.360.003.9651	690	142.380.003.9851	675	142.390.003.9951	695	142.300.004.1251
L = 660	716	142.360.009.9651	740	142.380.009.9851	725	142.390.009.9951	745	142.300.005.1251
L = 710	766	142.360.004.9651	790	142.380.004.9851	775	142.390.004.9951	795	142.300.006.1251
L = 760	816	142.360.010.9651	840	142.380.010.9851	825	142.390.010.9951	845	142.300.007.1251
L = 810	866	142.360.005.9651	890	142.380.005.9851	875	142.390.005.9951	895	142.300.008.1251
L = 860	916	142.360.011.9651	940	142.380.011.9851	925	142.390.011.9951	945	142.300.009.1251
L = 910	966	142.360.017.9651	990	142.380.017.9851	975	142.390.017.9951	995	142.300.010.1251
L = 1010	1066	142.360.012.9651	1090	142.380.012.9851	1075	142.390.012.9951	1095	142.300.011.1251
L = 1110	1166	142.360.013.9651	1190	142.380.013.9851	1175	142.390.013.9951	1195	142.300.012.1251
L = 1210	1266	142.360.014.9651	1290	142.380.014.9851	1275	142.390.014.9951	1295	142.300.013.1251
L = 1310	1366	142.360.015.9651	1390	142.380.015.9851	1375	142.390.015.9951	1395	142.300.014.1251
L = 1410	1466	142.360.016.9651	1490	142.380.016.9851	1475	142.390.016.9951	1495	142.300.015.1251

Per codifica e tipologia protezione vedere pag.
For coding and guard typology see pag.

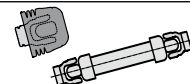

Esterna / Outer

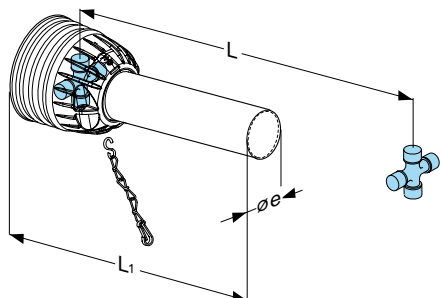

Interna / Inner

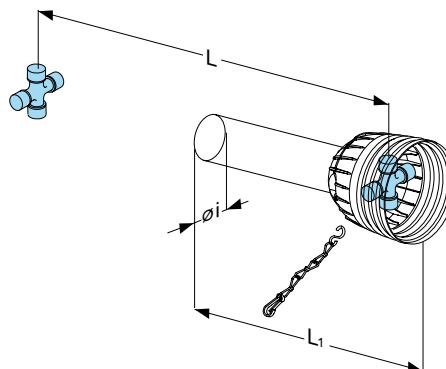

N-EN

Type	ø _e = 61 mm 10		ø _e = 61 mm 20		ø _e = 66.5 mm 40		ø _e = 81.2 mm 50		
	L ₁ [mm]	Code	L ₁ [mm]	Code	L ₁ [mm]	Code	L ₁ [mm]	Code	
Esterna / Outer	L = 410	327	142.316.006.7151	327	142.326.006.9251	313	142.346.006.9451	323	142.356.006.9551
	L = 460	377	142.316.001.7151	377	142.326.001.9251	363	142.346.001.9451	373	142.356.001.9551
	L = 510	427	142.316.007.7151	427	142.326.007.9251	413	142.346.007.9451	423	142.356.007.9551
	L = 560	477	142.316.002.7151	477	142.326.002.9251	463	142.346.002.9451	473	142.356.002.9551
	L = 610	527	142.316.008.7151	527	142.326.008.9251	513	142.346.008.9451	523	142.356.008.9551
	L = 660	577	142.316.003.7151	577	142.326.003.9251	563	142.346.003.9451	573	142.356.003.9551
	L = 710	627	142.316.009.7151	627	142.326.009.9251	613	142.346.009.9451	623	142.356.009.9551
	L = 760	677	142.316.004.7151	677	142.326.004.9251	663	142.346.004.9451	673	142.356.004.9551
	L = 810	727	142.316.010.7151	727	142.326.010.9251	713	142.346.010.9451	723	142.356.010.9551
	L = 860	777	142.316.005.7151	777	142.326.005.9251	763	142.346.005.9451	773	142.356.005.9551
	L = 910	827	142.316.011.7151	827	142.326.011.9251	813	142.346.011.9451	823	142.356.011.9551
	L = 1010	927	142.316.012.7151	927	142.326.012.9251	913	142.346.012.9451	923	142.356.012.9551
	L = 1110	1027	142.316.013.7151	1027	142.326.013.9251	1013	142.346.013.9451	1023	142.356.013.9551
	L = 1210	1127	142.316.014.7151	1127	142.326.014.9251	1113	142.346.014.9451	1123	142.356.014.9551
L = 1310	1227	142.316.015.7151	1227	142.326.015.9251	1213	142.346.015.9451	1223	142.356.015.9551	
L = 1410	1327	142.316.016.7151	1327	142.326.016.9251	1313	142.346.016.9451	1323	142.356.016.9551	

Type	ø _i = 55.6 mm 10		ø _i = 55.6 mm 20		ø _i = 61 mm 40		ø _i = 75 mm 50		
	L ₁ [mm]	Code	L ₁ [mm]	Code	L ₁ [mm]	Code	L ₁ [mm]	Code	
Interna / Inner	L = 410	327	142.317.006.7151	327	142.327.006.9251	313	142.347.006.9451	323	142.357.006.9551
	L = 460	377	142.317.001.7151	377	142.327.001.9251	363	142.347.001.9451	373	142.357.001.9551
	L = 510	427	142.317.007.7151	427	142.327.007.9251	413	142.347.007.9451	423	142.357.007.9551
	L = 560	477	142.317.002.7151	477	142.327.002.9251	463	142.347.002.9451	473	142.357.002.9551
	L = 610	527	142.317.008.7151	527	142.327.008.9251	513	142.347.008.9451	523	142.357.008.9551
	L = 660	577	142.317.003.7151	577	142.327.003.9251	563	142.347.003.9451	573	142.357.003.9551
	L = 710	627	142.317.009.7151	627	142.327.009.9251	613	142.347.009.9451	623	142.357.009.9551
	L = 760	677	142.317.004.7151	677	142.327.004.9251	663	142.347.004.9451	673	142.357.004.9551
	L = 810	727	142.317.010.7151	727	142.327.010.9251	713	142.347.010.9451	723	142.357.010.9551
	L = 860	777	142.317.005.7151	777	142.327.005.9251	763	142.347.005.9451	773	142.357.005.9551
	L = 910	827	142.317.011.7151	827	142.327.011.9251	813	142.347.011.9451	823	142.357.011.9551
	L = 1010	927	142.317.012.7151	927	142.327.012.9251	913	142.347.012.9451	923	142.357.012.9551
	L = 1110	1027	142.317.013.7151	1027	142.327.013.9251	1013	142.347.013.9451	1023	142.357.013.9551
	L = 1210	1127	142.317.014.7151	1127	142.327.014.9251	1113	142.347.014.9451	1123	142.357.014.9551
L = 1310	1227	142.317.015.7151	1227	142.327.015.9251	1213	142.347.015.9451	1223	142.357.015.9551	
L = 1410	1327	142.317.016.7151	1327	142.327.016.9251	1313	142.347.016.9451	1323	142.357.016.9551	

Per codifica e tipologia protezione vedere pag.
For coding and guard typology see pag.

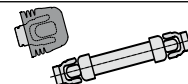

Esterna / Outer

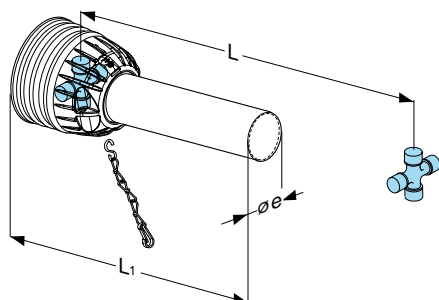

Interna / Inner

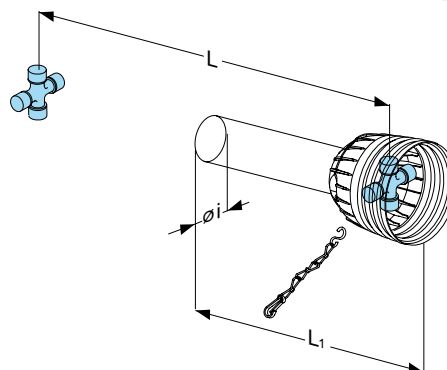

N-EN

Type	ø _e = 81.2 mm 60		ø _e = 96 mm 80		ø _e = 96 mm 90		ø _e = 96 mm 120		
	L ₁ [mm]	Code	L ₁ [mm]	Code	L ₁ [mm]	Code	L ₁ [mm]	Code	
Esterna / Outer	L = 410	313	142.366.001.9651	310	142.386.001.9851	295	142.396.001.9951	-	-
	L = 460	363	142.366.007.9651	360	142.386.007.9851	345	142.396.007.9951	339	142.306.001.1251
	L = 510	413	142.366.002.9651	410	142.386.002.9851	395	142.396.002.9951	389	142.306.002.1251
	L = 560	463	142.366.008.9651	460	142.386.008.9851	445	142.396.008.9951	439	142.306.003.1251
	L = 610	513	142.366.003.9651	510	142.386.003.9851	495	142.396.003.9951	489	142.306.004.1251
	L = 660	563	142.366.009.9651	560	142.386.009.9851	545	142.396.009.9951	599	142.306.005.1251
	L = 710	613	142.366.004.9651	610	142.386.004.9851	595	142.396.004.9951	589	142.306.006.1251
	L = 760	663	142.366.010.9651	660	142.386.010.9851	645	142.396.010.9951	639	142.306.007.1251
	L = 810	713	142.366.005.9651	710	142.386.005.9851	695	142.396.005.9951	689	142.306.008.1251
	L = 860	763	142.366.011.9651	760	142.386.011.9851	745	142.396.011.9951	739	142.306.009.1251
	L = 910	813	142.366.033.9651	810	142.386.017.9851	795	142.396.017.9951	789	142.306.010.1251
	L = 1010	913	142.366.012.9651	910	142.386.012.9851	895	142.396.012.9951	889	142.306.011.1251
	L = 1110	1013	142.366.013.9651	1010	142.386.013.9851	995	142.396.013.9951	989	142.306.012.1251
	L = 1210	1113	142.366.014.9651	1110	142.386.014.9851	1095	142.396.014.9951	1089	142.306.013.1251
L = 1310	1213	142.366.015.9651	1210	142.386.015.9851	1195	142.396.015.9951	1189	142.306.014.1251	
L = 1410	1313	142.366.016.9651	1310	142.386.016.9851	1295	142.396.016.9951	1289	142.306.015.1251	

Type	ø _i = 75 mm 60		ø _i = 89.9 mm 80		ø _i = 89.9 mm 90		ø _i = 89.9 mm 120		
	L ₁ [mm]	Code	L ₁ [mm]	Code	L ₁ [mm]	Code	L ₁ [mm]	Code	
Interna / Inner	L = 410	313	142.367.001.9651	310	142.387.001.9851	295	142.397.001.9951	-	-
	L = 460	363	142.367.007.9651	360	142.387.007.9851	345	142.397.007.9951	339	142.307.001.1251
	L = 510	413	142.367.002.9651	410	142.387.002.9851	395	142.397.002.9951	389	142.307.002.1251
	L = 560	463	142.367.008.9651	460	142.387.008.9851	445	142.397.008.9951	439	142.307.003.1251
	L = 610	513	142.367.003.9651	510	142.387.003.9851	495	142.397.003.9951	489	142.307.004.1251
	L = 660	563	142.367.009.9651	560	142.387.009.9851	545	142.397.009.9951	539	142.307.005.1251
	L = 710	613	142.367.004.9651	610	142.387.004.9851	595	142.397.004.9951	589	142.307.006.1251
	L = 760	663	142.367.010.9651	660	142.387.010.9851	645	142.397.010.9951	639	142.307.007.1251
	L = 810	713	142.367.005.9651	710	142.387.005.9851	695	142.397.005.9951	689	142.307.008.1251
	L = 860	763	142.367.011.9651	760	142.387.011.9851	745	142.397.011.9951	739	142.307.009.1251
	L = 910	813	142.367.033.9651	810	142.387.017.9851	795	142.397.017.9951	789	142.307.010.1251
	L = 1010	863	142.367.012.9651	860	142.387.012.9851	845	142.397.012.9951	889	142.307.011.1251
	L = 1110	913	142.367.013.9651	910	142.387.013.9851	895	142.397.013.9951	939	142.307.012.1251
	L = 1210	963	142.367.014.9651	960	142.387.014.9851	945	142.397.014.9951	939	142.307.012.1251
L = 1310	1013	142.367.015.9651	1010	142.387.015.9851	995	142.397.015.9951	939	142.307.012.1251	
L = 1410	1063	142.367.016.9651	1060	142.387.016.9851	1045	142.397.016.9951	939	142.307.012.1251	

Per codifica e tipologia protezione vedere pag.
For coding and guard typology see pag.

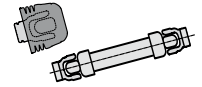

Cuffia / Cone

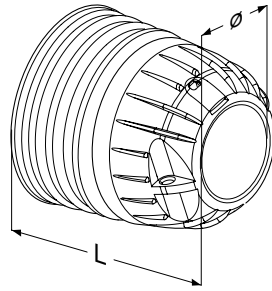

Versione Version	10		20		40		50		60		80		90		120	
	L [mm]	Code	L [mm]	Code	L [mm]	Code	L [mm]	Code	L [mm]	Code	L [mm]	Code	L [mm]	Code	L [mm]	Code
Corta Short	69	180.032.401	69	180.032.401	84	180.034.536	92	180.036.634	92	180.036.634	103	180.039.362	103	180.039.362	-	-
Standard	127	180.032.417	127	180.032.417	138	180.034.578	153	180.036.709	153	180.036.709	180	180.039.367	189	180.039.398	206	180.123.041
Lunga Long	216	180.032.468	216	180.032.468	229	180.034.755	262	180.036.885	262	180.036.885	-	-	-	-	-	-

Ghiera / Retaining Collar

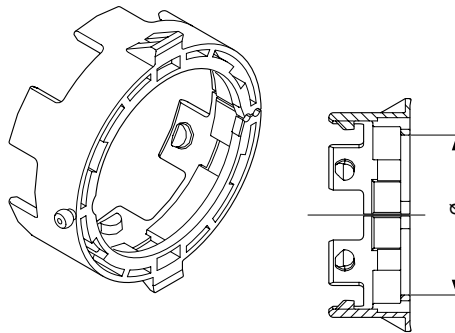

	10	20	40	50	60	80	90	90
Esterna Outer	ø = 40 mm	ø = 46 mm	ø = 54 mm	ø = 62.5 mm	ø = 69 mm	ø = 81.5 mm	ø = 81.5 mm	ø = 81.5 mm
	Code	Code	Code	Cod	Code	Code	Code	Code
	180.011.342	180.012.380	180.014.505	180.015.391	180.016.596	180.019.353	180.019.353	180.019.353
Interna Inner	ø = 34 mm	ø = 40 mm	ø = 47 mm	ø = 54.5 mm	ø = 60 mm	ø = 69.5 mm	ø = 69.5 mm	ø = 69.5 mm
	Code	Code	Code	Cod	Code	Code	Code	Code
	180.011.343	180.012.381	180.014.506	180.015.390	180.016.595	180.019.354	180.019.354	180.019.354

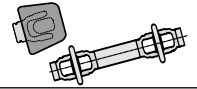

Cuffia con ghiera / Cone with retaining collar

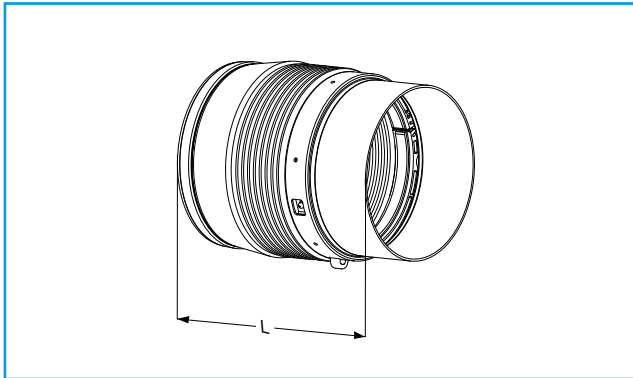

Versione Version	20		40		60		80	
	L [mm]	Code	L [mm]	Code	L [mm]	Code	L [mm]	Code
N-EN	202	180.022.483	221	180.024.785	233	180.026.806	269	180.028.606

Ghiera / Retaining collar

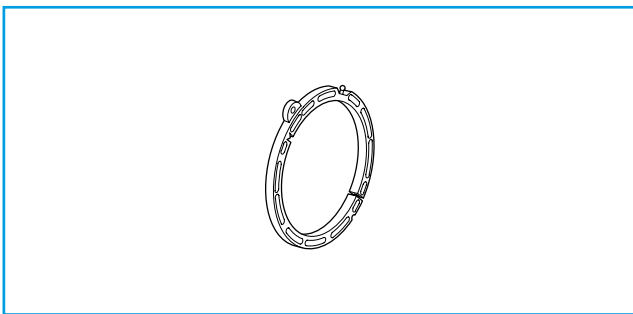

Versione Version	20		40		60		80	
	∅ [mm]	Code	∅ [mm]	Code	∅ [mm]	Code	∅ [mm]	Code
N-EN	171	158.012.482	187	158.016.615	187	158.016.615	210	158.018.470

Kit cuffia / Guard Cone Set

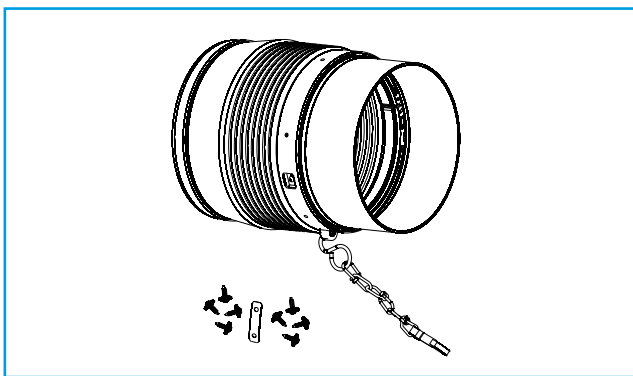

Versione Version	20	40	60	80
	Code	Code	Code	Code
N-EN	165.000.853	165.000.848	165.000.789	165.000.784

Catenella di sicurezza / Safety Chain

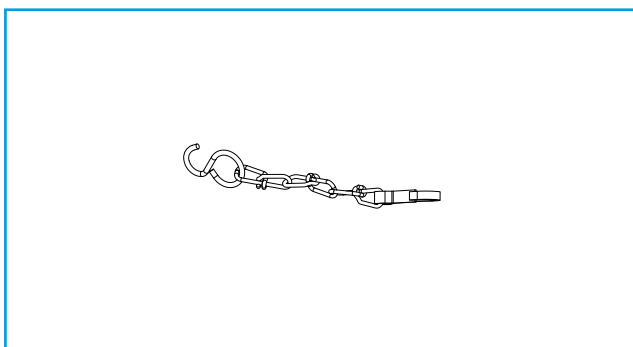

Code 180.016.790

CONTROCUFFIE FISSE
FIXED COUNTER-CONES

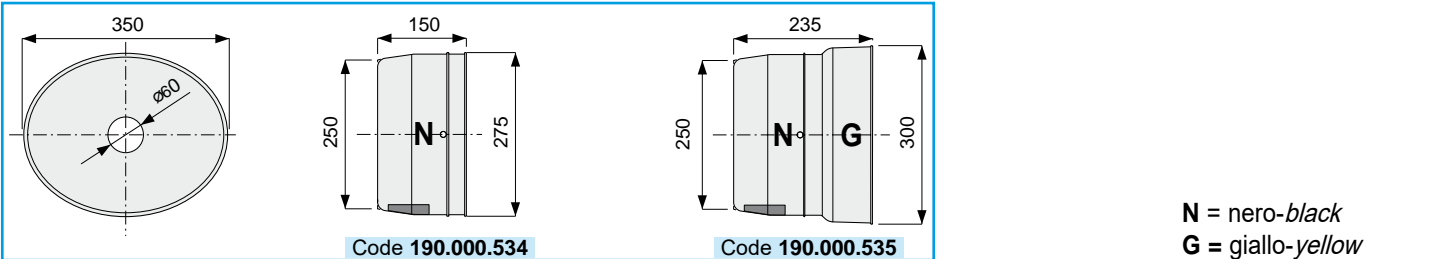
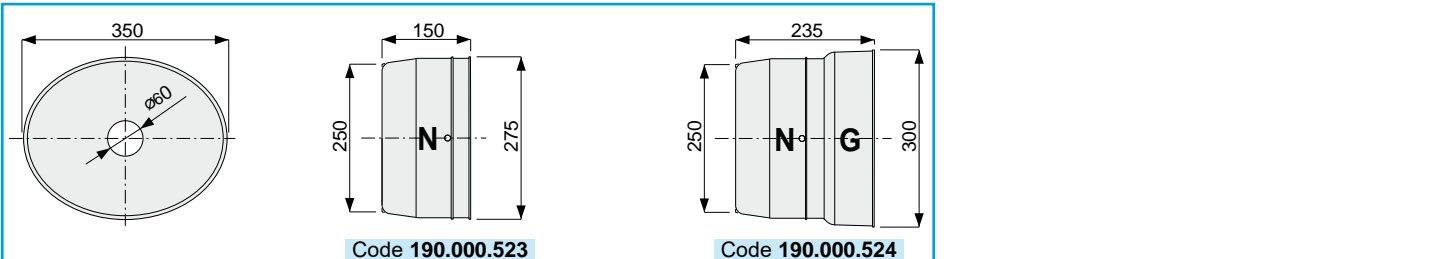
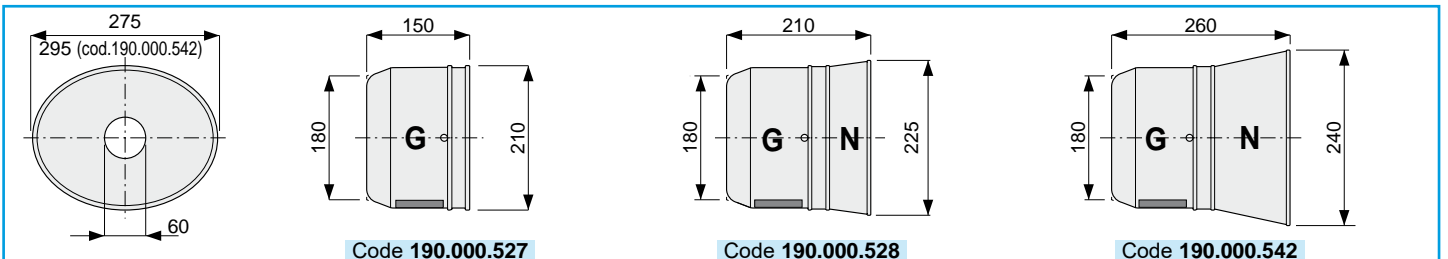
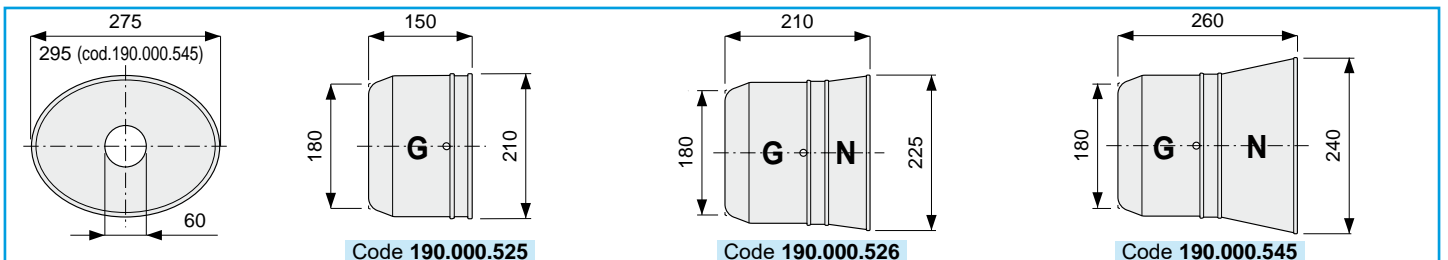
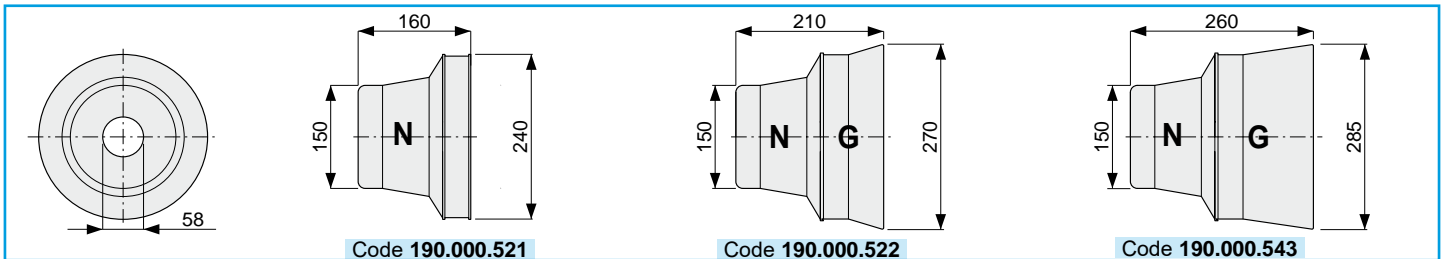
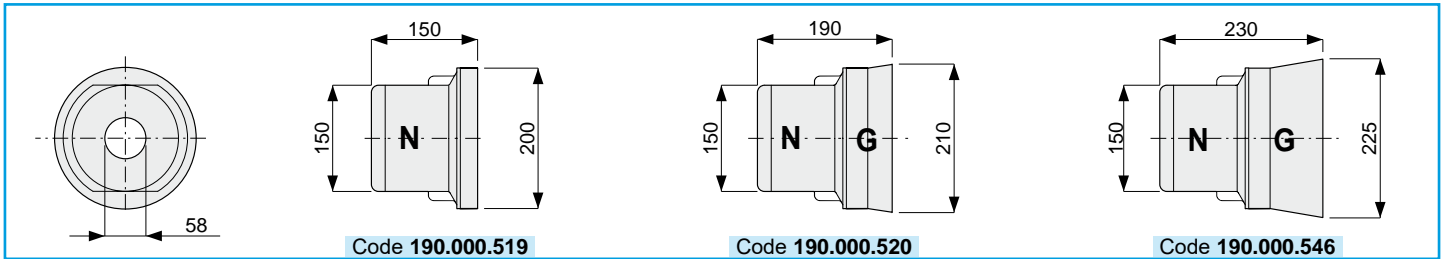
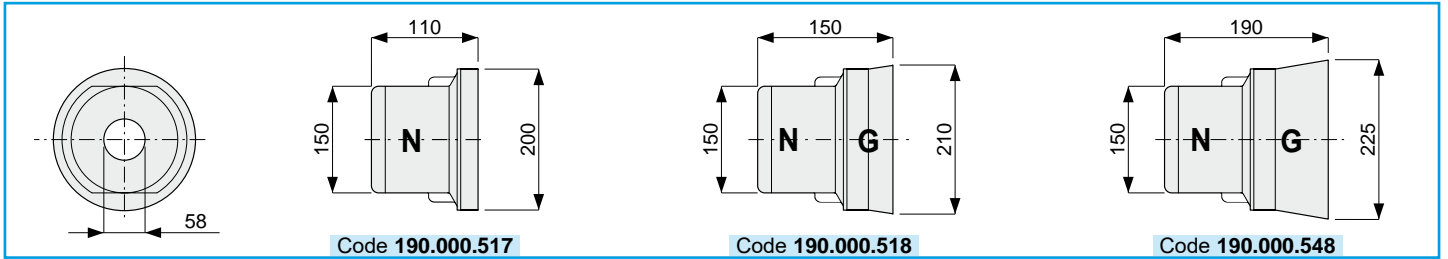
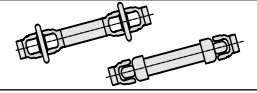

N = nero-black
G = giallo-yellow

CONTROCUFFIE AMOVIBILI REMOVABLE COUNTER-CONES

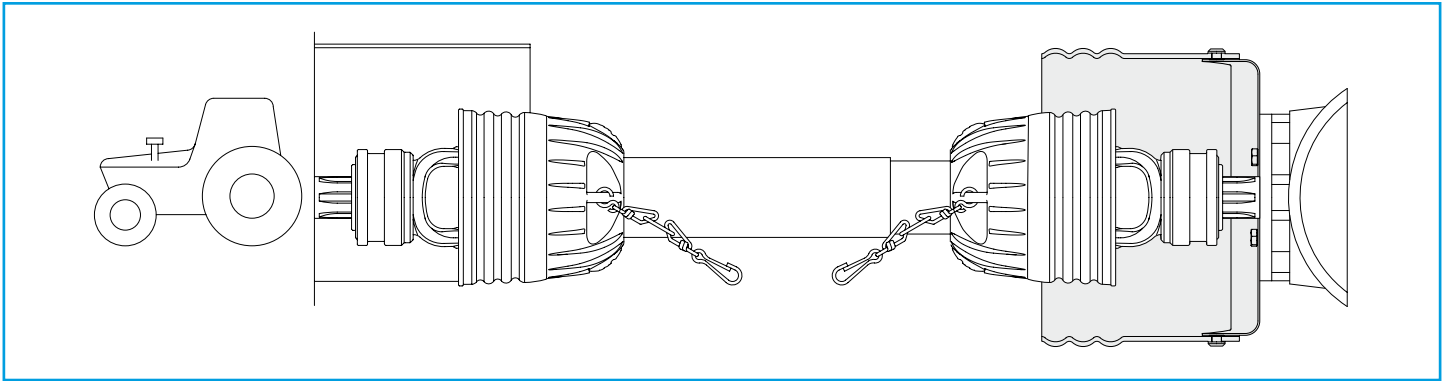
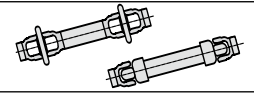

La contro cuffia amovibile è costituita da un fondello metallico e da una fascia di protezione in plastica fissata al fondello mediante due bulloni. In tale condizione essa garantisce l'azione di protezione indicata dalla "direttiva macchine 2006/42/CE". Allentando i due bulloni con una chiave la fascia di protezione si sgancia dal fondello e può scorrere sulla trasmissione per consentire un' agevole accesso agli organi di trasmissione nelle operazioni d'installazione o manutenzione. Tale peculiarità viene esaltata se la contro cuffia amovibile è impiegata in abbinamento con alberi cardanici aventi le protezioni di tipo EN.

The removable counter-cone consists of a metal Bolttom and a plastic guard attached to the Bolttom with two bolts. In this condition, the counter-cone guarantees the protection prescribed by "EEC Machine Directive 2006/42". After loosening the two bolts with a wrench, the guard is released from the Bolttom and can slide on the transmission and thus provide easy access to transmission parts during installation or maintenance. This special feature becomes even more effective if the removable counter-cone is used together with driveshafts equipped with EN guards.

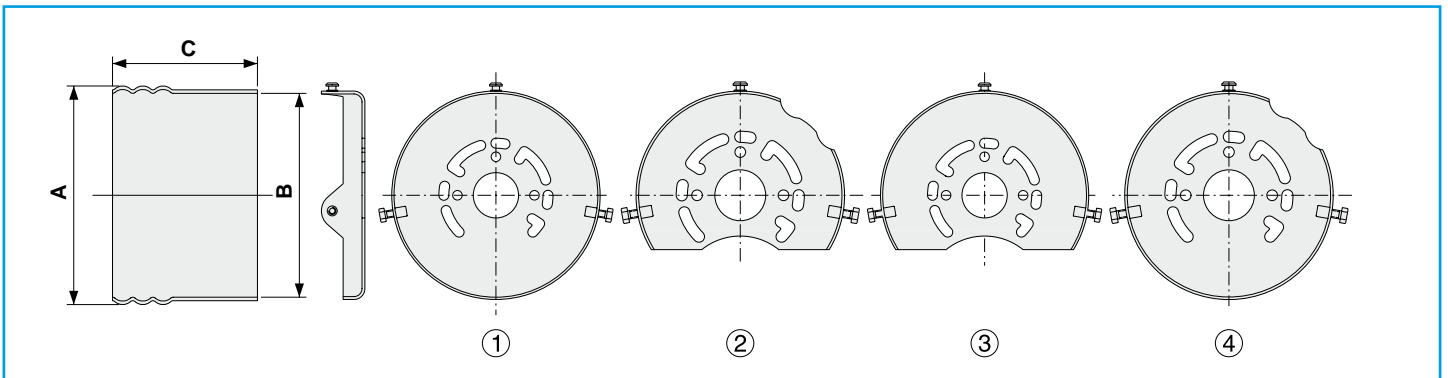

		C												
A	B	140	160	180	210	230	250	280	300	320	1	2	3	4
200 7 31/64"	182 7 11/64"	5 33/64" 180/140	6 19/64" 180/160	7 3/32" 180/180	8 17/64" 180/210	9 1/16" 180/230	9 27/32" 180/250	11 1/32" -	11 13/16" -	12 29/64" -	180/1	180/2	-	-
225 8 15/32"	207 8 5/32"	205/140	205/160	205/180	205/210	205/230	205/250	205/280	-	-	205/1	205/2	205/3	205/4
250 9 29/64"	232 9 9/64"	230/140	230/160	230/180	230/210	230/230	230/250	230/280	230/300	230/320	230/1	230/2	230/3	230/4

ESEMPI D'APPLICAZIONE APPLICATION EXAMPLES

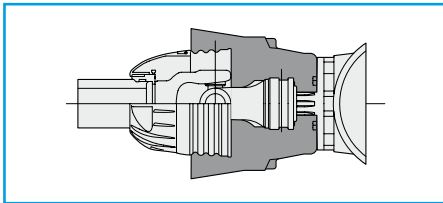
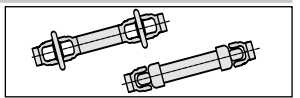

Code 190.000.517 - 190.000.518 - 190.000.548
Code 190.000.519 - 190.000.520 - 190.000.546

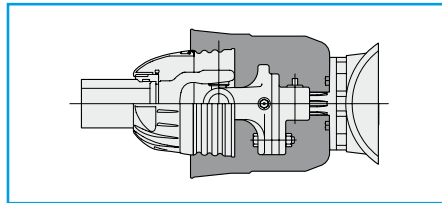

Code 190.000.525-190.000.526-190.000.545-190.000.527-190.000.528-190.000.542

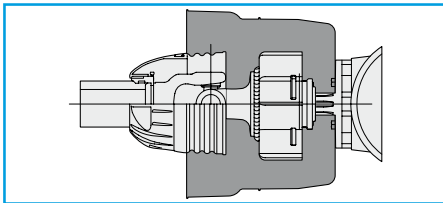
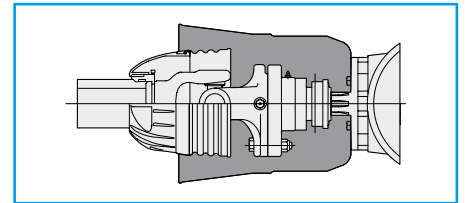

Code 190.000.523 - 190.000.524 - 190.000.534
Code 190.000.535

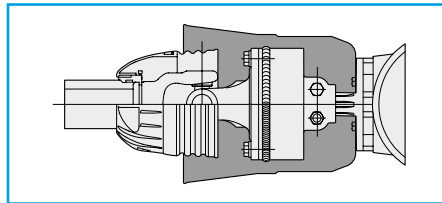

Code 190.000.525 - 190.000.526 - 190.000.545
Code 190.000.527 - 190.000.528 - 190.000.542

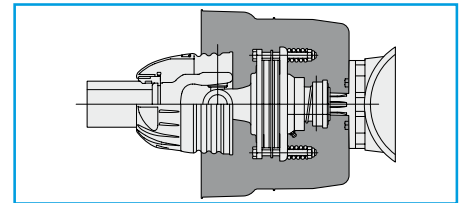

Code 190.000.523 - 190.000.524 - 190.000.534
Code 190.000.535

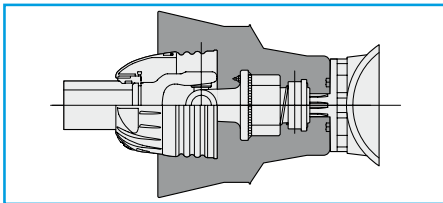

Code 190.000.521-190.000.522-190.000.543

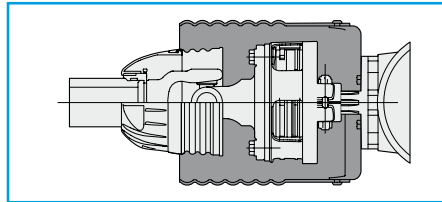
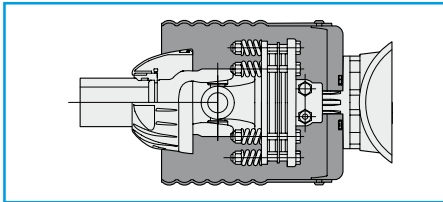
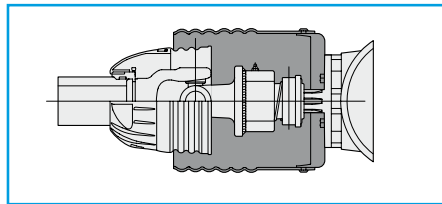
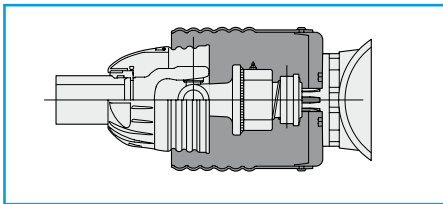
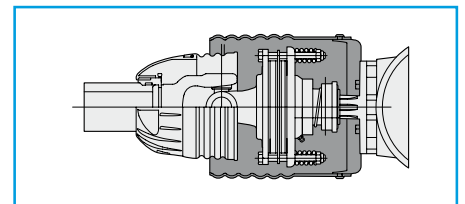
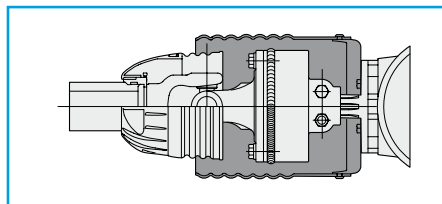
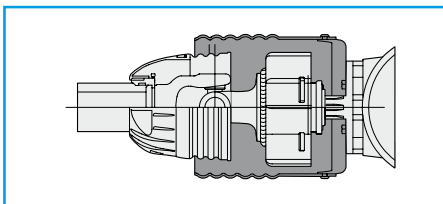
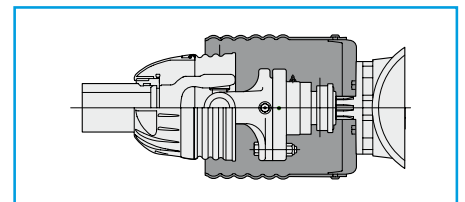
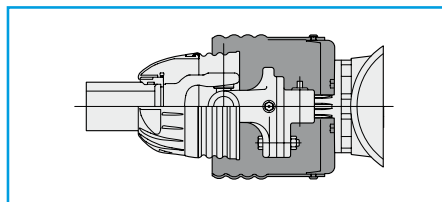
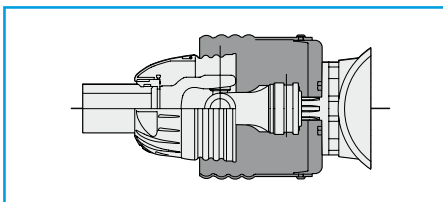
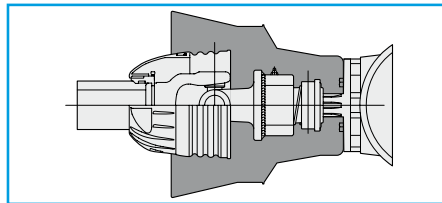

Vista l'elevata possibilità di combinazioni attuali con questo tipo di controprotezione, l'indicare un tipo piuttosto che un altro potrebbe risultare fuorviante. Al fine di effettuare una scelta corretta, si consiglia pertanto di controllare l'ingombro del dispositivo, della cuffia di protezione e la sovrapposizione tra cuffia e controprotezione (min 50 mm)

Considering the combinations that can be created with this type of counter-guard, indicating one type instead of another might be misleading. To choose the correct type, it is recommended to check the overall dimensions of the guard cone and the overlap between the cone and counter-guard (minimum 50 mm).

			p.
INTRODUZIONE INTRODUCTION			146
ALBERI CARDANICI PTO DRIVESHAFTS			146
Trasmissioni primarie CE	<i>CE Primary Trasmissions</i>		146
Trasmissioni primarie USA	<i>USA Primary Trasmissions</i>		147
Trasmissioni primarie CANADA	<i>CANADA Primary Trasmissions</i>		148
NORME D'USO OPERATING INSTRUCTIONS			149
NORME GENERALI GENERAL RULES			151
NORME GENERALI DI SICUREZZA PER CONTROCUFFIE GENERAL SAFETY ROULES FOR COUNTER CONE			151



Introduzione / Introduction

Comer Industries S.p.A. considera da sempre la sicurezza tra i più importanti parametri progettuali e costruttivi dei suoi prodotti che sono realizzati in conformità alle normative ISO e alle direttive CEE sulla sicurezza. Informazioni sulla sicurezza e corretto utilizzo da parte dell'utilizzatore sono forniti dalle etichette di sicurezza e dal libretto di "Uso e Manutenzione" forniti ad ogni trasmissione. E' cura del cliente informare Comer Industries S.p.A. sul paese in cui le trasmissioni verranno destinate, affinché sia possibile dotarle di idonee libretti ed etichette

Comer Industries S.p.A has always considered safety to be one of the most important design and construction parameters for its products which are all built in full compliance with the international ISO standard and EU safety regulations.

Information on safety and on correct final user's application of the PTO driveshaft are supplied in safety labels and in the "Use and Maintenance" Manual provided with all PTO driveshafts. It is the customer responsibility to inform Comer Industries S.p.A. about the Country to which the PTO driveshafts will be delivered, in order to provide them with the suitable Manuals and Labels

Alberi cardanici / PTO driveshaft

Trasmissioni primarie CE / CE Primary Transmission

Collegano il trattore alla macchina operatrice e sono equipaggiate con:

They connect the tractor to the operating machinery and are equipped with:

- Marchio CE
- Etichette sicurezza
- Libretto d'istruzione CE
- Catene antirotazione

- CE Mark
- Safety labels
- CE instruction handbook
- anti-rotation chains

Etichetta su tubo protezione esterno



Label on outer protective tube

Code **190.000.359**

Etichetta su tubo in acciaio esterno



Label on outer steel tube

Code **190.000.358**

Libretto "Uso e Manutenzione" CE



CE "Use and Maintenance" handbook



Trasmissioni primarie USA / USA Primary Trasmision

Collegano il trattore alla macchina operatrice e sono equipaggiate con: They connect the tractor to the operating machinery and are equipped with:

- Etichette sicurezza
- Libretto d'istruzione
- Catene antirrotazione
- Safety labels
- Instruction handbook
- Anti-rotation chains

Etichetta su tubo protezione esterno



Label on outer protective tube

Code **190.000.099**

Etichetta su tubo in acciaio esterno



Label on outer steel tube

Code **190.000.098**

Libretto "Uso e Manutenzione"

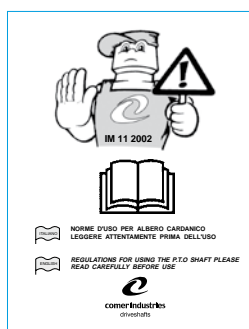

"Use and Maintenance" handbook

Code **190.000.371**

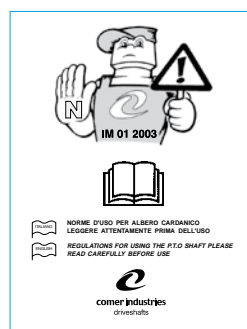

Code **190.000.692**

L'albero cardanico può essere fornito a richiesta senza le protezioni. In questo caso è responsabilità dell'acquirente omologare la macchina (compresa dell'albero) secondo la Direttiva Macchine e proteggere la trasmissione cardanica con protezioni idonee

On request, the driveshaft can be supplied without safety guards. In this case, the buyer is responsible for certifying the machine (including the shaft) according to the Machine Directive and for mounting suitable safety guards for the driveshaft



Trasmissioni primarie CANADA / CANADA Primary Transmission

Collegano il trattore alla macchina operatrice e sono equipaggiate con:

- Etichette sicurezza
- Libretto d'istruzione
- Catene antirotazione

They connect the tractor to the operating machinery and are equipped with:

- Safety labels
- Instruction handbook
- Anti-rotation chains

Etichette su tubo protezione esterno



Code 190.000.359

Labels on outer protective tube



Code 190.000.215

Etichetta su tubo in acciaio esterno



Code 190.000.216

Label on outer steel tube

Libretto "Uso e Manutenzione"

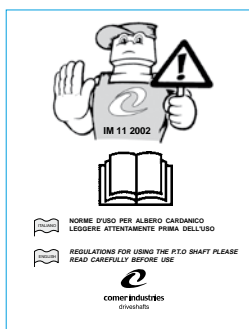

Code 190.000.371

"Use and Maintenance" handbook

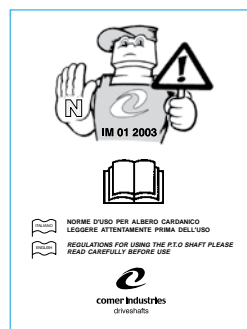

Code 190.000.692

L'albero cardanico può essere fornito a richiesta senza le protezioni. In questo caso è responsabilità dell'acquirente omologare la macchina (compresa dell'albero) secondo la Direttiva Macchine e proteggere la trasmissione cardanica con protezioni idonee

On request, the driveshaft can be supplied without safety guards. In this case, the buyer is responsible for certifying the machine (including the shaft) according to the Machine Directive and for mounting suitable safety guards for the driveshaft



Norme d'uso / Operating instruction



Quanto descritto riguarda la vostra sicurezza.
Prima di iniziare il lavoro assicurarsi che:

*These rules concern your safety.
Before starting to work, make sure that:*

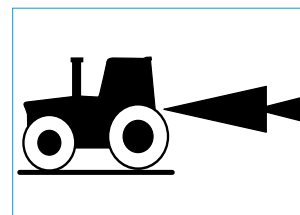
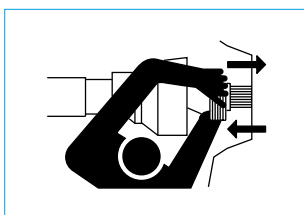

la trasmissione cardanica sia correttamente fissata al trattore ed alla macchina operatrice. (Il trattorino stampigliato sulla protezione indica il lato trattore)

the transmission is correctly connected to the tractor and to the operating machinery (the picture of the small tractor stamped on the safety guard indicates the tractor side)

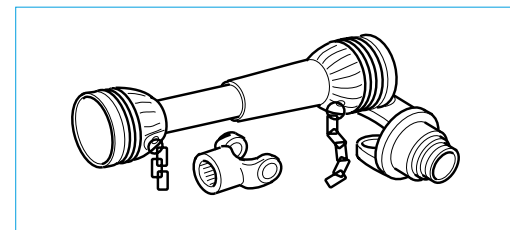
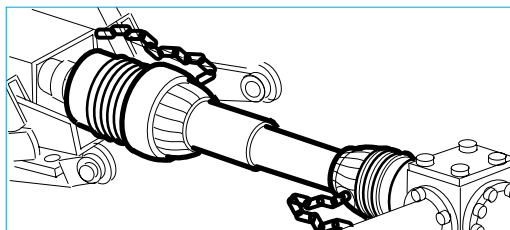

tutte le protezioni della trasmissione siano presenti ed efficienti, eventuali elementi danneggiati o mancanti devono essere sostituiti con Ricambi originali ed installati correttamente

all the transmission safety guards are in position and operating efficiently. Any damaged or missing components must be replaced with original spare parts and installed correctly

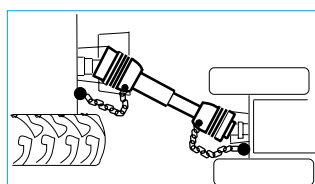

le catene devono essere fissate in modo che permettano l'articolazione della trasmissione in ogni condizione di lavoro e di trasporto

the chains must be connected so that the transmission can move under all operating and transport conditions

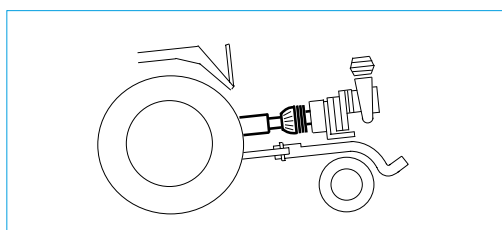

le macchine stazionarie (pompe, generatori, etc ..) siano sempre agganciate al trattore e rispettino la sovrapposizione degli elementi telescopici

the stationary machines (pumps, generators, etc.) are always coupled to the tractor and respect the position of the overlapping telescopic elements



la trasmissione cardanica sia idonea per lunghezza, dimensione ed eventuale dispositivo (controllare nel libretto d'istruzioni della macchina se la trasmissione deve essere dotata di limitatore di coppia o ruota libera)

the driveshaft transmission in terms of length, size and any device (check the machine's instruction handbook if the transmission must be equipped with a torque limiter or overrunning clutch)



Durante l'utilizzo della trasmissione assicurarsi che :

When using the transmission, make sure that:

la trasmissione cardanica non superi le condizioni di velocità e di potenza stabilite nel manuale della macchina.
L'eventuale dispositivo di sicurezza deve essere impegnato sul lato macchina.
Tutte le parti in rotazione siano protette

*the driveshaft does not exceed the speed and power conditions defined in the machine's operating handbook.
Any safety device must be engaged on the machine side.
All rotating parts must be protected.*

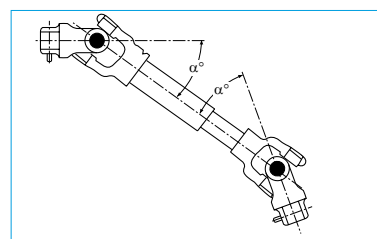
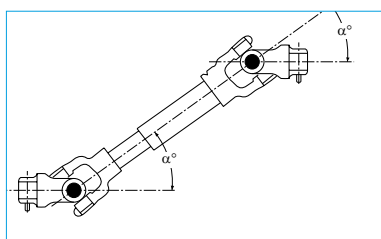

gli angoli di snodo siano contenuti ed uguali. In caso di manovre che superino i 35° disinserire la presa di moto

the joint angles are limited and equal; for operations that exceed 35°, disengage the power take-off

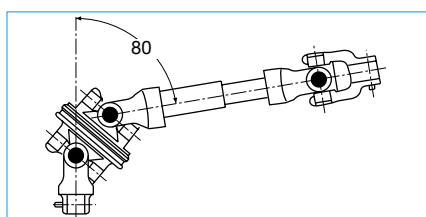

il giunto omocinetico non operi in continuo con un angolo prossimo a 80°, ma solamente per brevi periodi (sterzate)

the PTO driveshaft joint does not operate continuously with an angle close to 80°, but only for brief periods (steering)

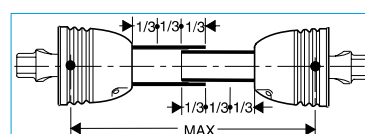
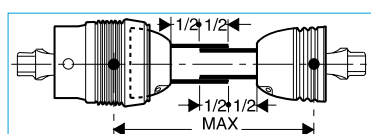

gli elementi telescopici della trasmissione siano sempre sovrapposti per 1/3 nelle trasmissioni STD, ed 1/2 nelle trasmissioni con giunto omocinetico

1/3 of the transmission's telescopic elements are always overlapping in the STD transmission and 1/2 in the PTO driveshaft transmissions



gli abiti di lavoro indossati non presentino cinghie, lembi o parti che possano costituire aggancio. L'eventuale contatto con parti in rotazione può provocare gravi incidenti

work clothes do not have belts, edges or parts that may get tangled. Any contact with rotating parts may cause serious accidents

Norme generali / General rules

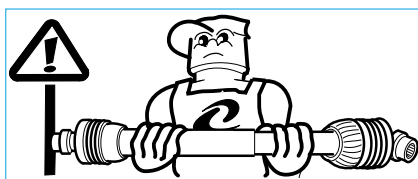

La trasmissione deve essere trasportata orizzontalmente per evitare (causa lo sfilamento) incidenti o rottura delle protezioni. In funzione del peso utilizzare adeguati mezzi di trasporto.

The transmission must be transported horizontally to prevent accidents (since it may slip out) or to avoid damage to safety guards. Depending on the weight, use a suitable means of transport.

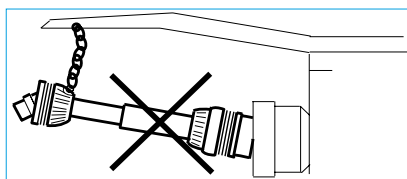

Non utilizzare le catene per trasportare o sostenere la trasmissione cardanica al termine dell'utilizzo. Usare un apposito supporto

Do not use chains to transport or support the driveshaft after use. Use a special support



Non usare la trasmissione come appoggio o come predellino

Do not use the transmission as a support or as a footboard

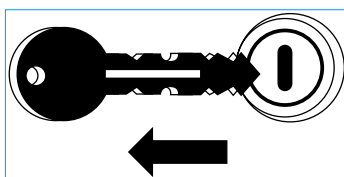

Spegnere il motore, togliere le chiavi del trattore e verificare che tutte le parti in rotazione si siano arrestate prima di avvicinarsi alla macchina operatrice o compiere operazioni di manutenzione

Turn off the engine, remove the key from the tractor and ensure that all rotating parts have stopped before getting close to the machinery or carrying out maintenance

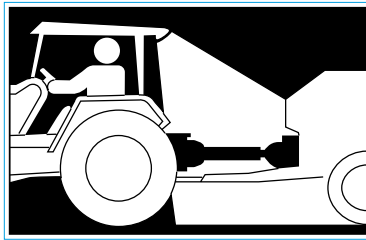

La zona di lavoro della trasmissione deve essere illuminata nelle fasi di installazione e di utilizzo nel caso di scarsa visibilità o utilizzo notturno

The transmission work area must be illuminated during installation and use in case of poor visibility or nighttime operation

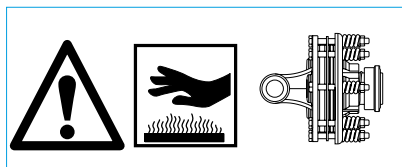

Le frizioni possono raggiungere temperature elevate.

NON TOCCARE!

Mantenere la zona adiacente pulita per evitare rischi d'incendio

Clutches may become very hot.

DO NOT TOUCH!

Keep the adjacent area clean to reduce the risk of fire

Norme generali di sicurezza per controcffie / General Safety Rule for Shrouds

La Direttiva Macchine (98/37/CEE) stabilisce che la presa di moto sulla macchina operatrice sia dotata di una protezione fissata alla stessa che permetta il montaggio e l'articolazione della trasmissione cardanica e che garantisca (secondo la norma EN 1553) una sovrapposizione di almeno 50mm con la protezione della trasmissione cardanica allineata.

The Machine Directive (98/37/CEE) states that the power take-off on operating machinery must be equipped with a safety shroud attached to it that allows the driveshaft to be assembled and to articulate and that guarantees (according to EN 1553) overlapping of at least 50 mm with the aligned driveshaft safety guard.

Le controcffie Comer Industries S.p.A. sono state realizzate rispettando i requisiti e le norme internazionali e vengono fornite corredate del foglio d'istruzione CE contenente la Dichiarazione di conformità

The Comer Industries S.p.A. shrouds are built in compliance with international requirements and standards and are supplied with a CE instruction sheet containing the declaration of conformity.

Data la notevole varietà di macchine operatrici e di applicazione, è responsabilità del costruttore della macchina selezionare la controcffia in base alle condizioni di impiego, alle dimensioni e all'articolazione della trasmissione cardanica.

Considering the wide variety of operating machinery and applications, the machine manufacturer is responsible for selecting the shroud based on the use conditions, dimensions and articulation of the driveshaft.

Comer Industries S.p.A. raccomanda di verificare in campo le reali condizioni di impiego ed idoneità della controcffia

Comer Industries S.p.A. recommends checking the real use conditions in the field as well as the suitability of the shroud

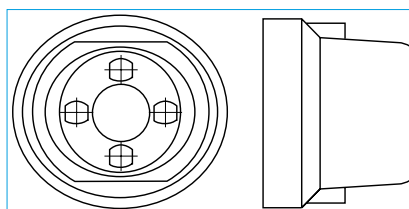

Le viti e rondelle di fissaggio della controcffia devono essere contenute nella superficie piana e non devono risultare allentate

Shroud connecting screws and washers must remain within the flat surface and should not be loose.

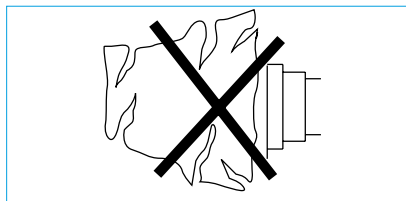

Le controcuffie non devono essere danneggiate, se tali devono essere sostituiti con Ricambi Originali

Shrouds must not be damaged. If so, they must be replaced with original spare parts

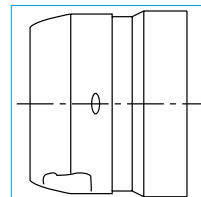

Non usare la controcuffia come appoggio o predellino. Assicurarsi che l'eventuale sportello sia chiuso

Do not use the shroud as a support or footboard. Any opening must be closed

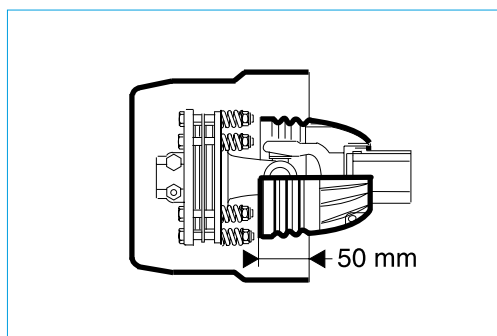

La controcuffia deve sormontare la protezione dell'albero cardanico di almeno 50mm

The shroud must overlap the driveshaft safety guard by at least 50 mm

DIMENSIONI PROFILI
SPLINED DIMENSIONS

1 1/8" Z6

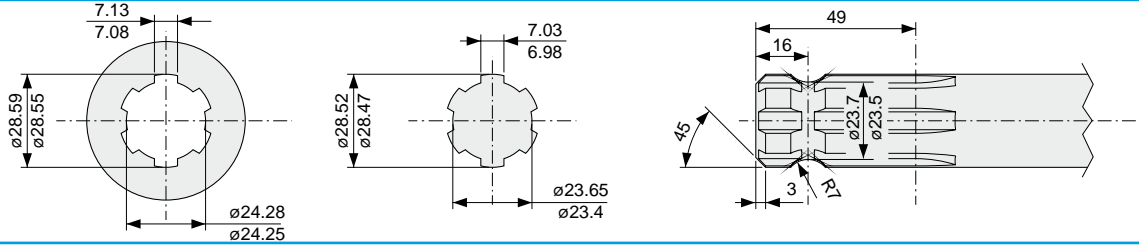

1 3/8" Z6

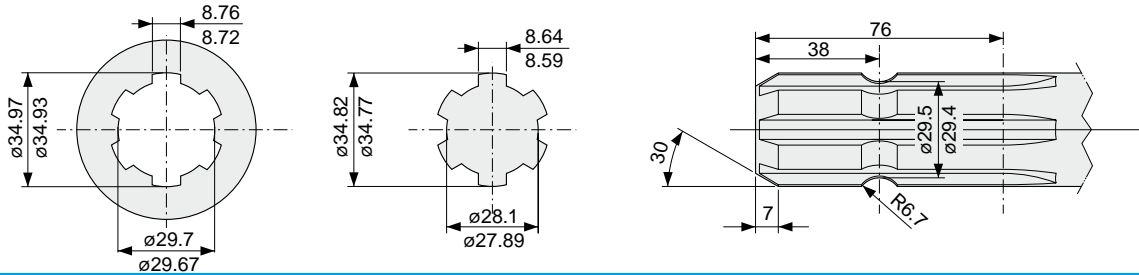

1 3/8" Z21

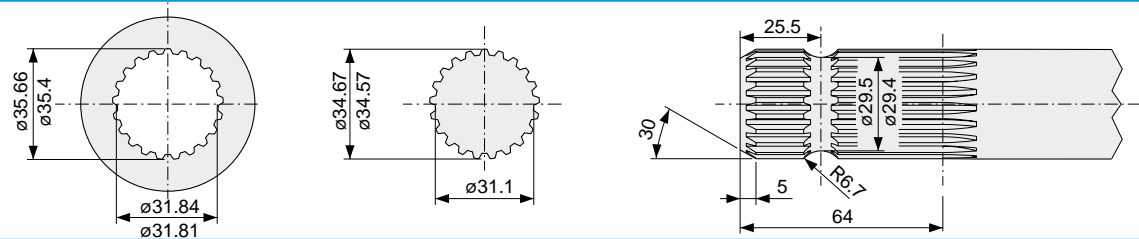

1 3/4" Z20

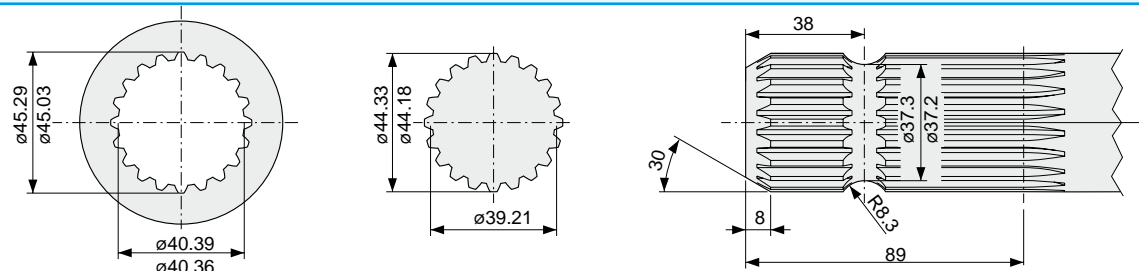

1 3/4" Z6

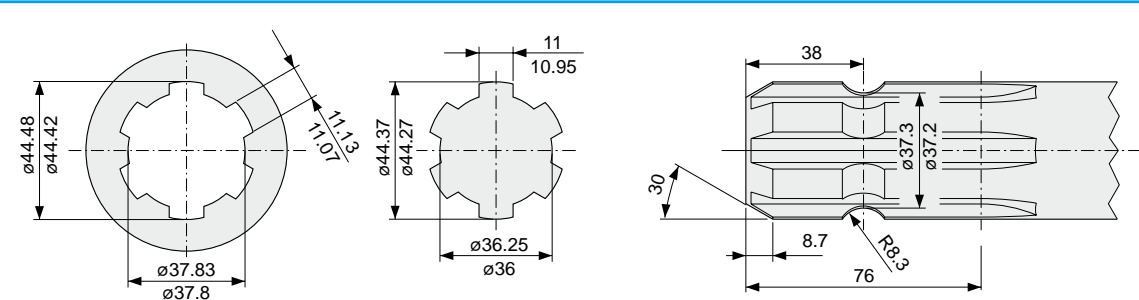

8 x 32 x 38

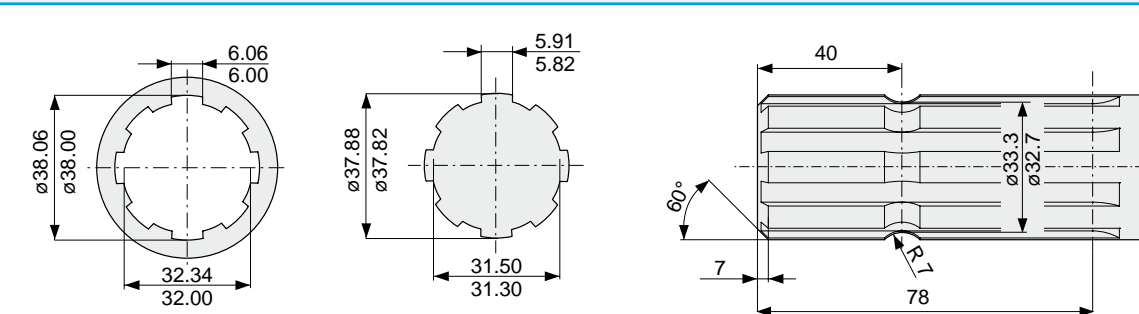

CONVERSIONI UNITÀ DI MISURA

MEASURE UNITS CONVERSIONS

		Lenght					
		[mm]	[cm]	[m]	[in]	[ft]	[yd]
1	[mm]	1	10 ⁻¹	10 ⁻³	39.37 10 ⁻³	3.2808 10 ⁻³	1.0936 10 ⁻³
1	[cm]	10	1	10 ⁻²	39.37 10 ⁻²	3.2808 10 ⁻²	1.0936 10 ⁻²
1	[m]	1000	100	1	39.37	3.28	1.09
1	[in]	25.4	2.54	2.54 10 ⁻²	1	0.08333	0.02778
1	[ft]	304.8	30.48	3.048 10 ⁻¹	12	1	0.33333
1	[yd]	914.4	91.44	0.9144	36	3	1

		Weight			
		[Kg]	[t]	[lb]	[oz]
1	[kg]	1	10 ⁻³	2.20462	35.274
1	[t]	1000	1	2204.62	35274
1	[lbf]	0.453592	0.4536 10 ⁻³	1	16
1	[oz]	2.8349 10 ⁻²	2.8349 10 ⁻⁵	6.25 10 ⁻²	1

		Force			
		[Kgp]	[N]	[lbf]	[pdl]
1	[kgp]	1	9.80665	2.205	73.76
1	[N]	0.10197	1	0.22481	7.233
1	[lbf]	0.4536	4.44822	1	32.18
1	[pdl]	13.56 10 ⁻³	0.138255	31.08 10 ⁻³	1

		Torque			
		[Kgp-m]	[N-m]	[lbf-in]	[lbf-ft]
1	[Kgp-m]	1	9.80665	86.7961	7.2329
1	[N-m]	0.10197	1	8.85079	0.73756
1	[lbf-in]	0.01152	0.11298	1	0.08333
1	[lbf-ft]	0.13826	1.35582	12	1

		Power			
		[W]	[kW]	[CV]	[HP]
1	[W]	1	10 ⁻³	1.360 10 ⁻³	1.341 10 ⁻³
1	[kW]	1000	1	1.360	1.341022
1	[CV]	735.50	0.7355	1	0.98632
1	[HP]	745.70	0.7457	1.01387	1

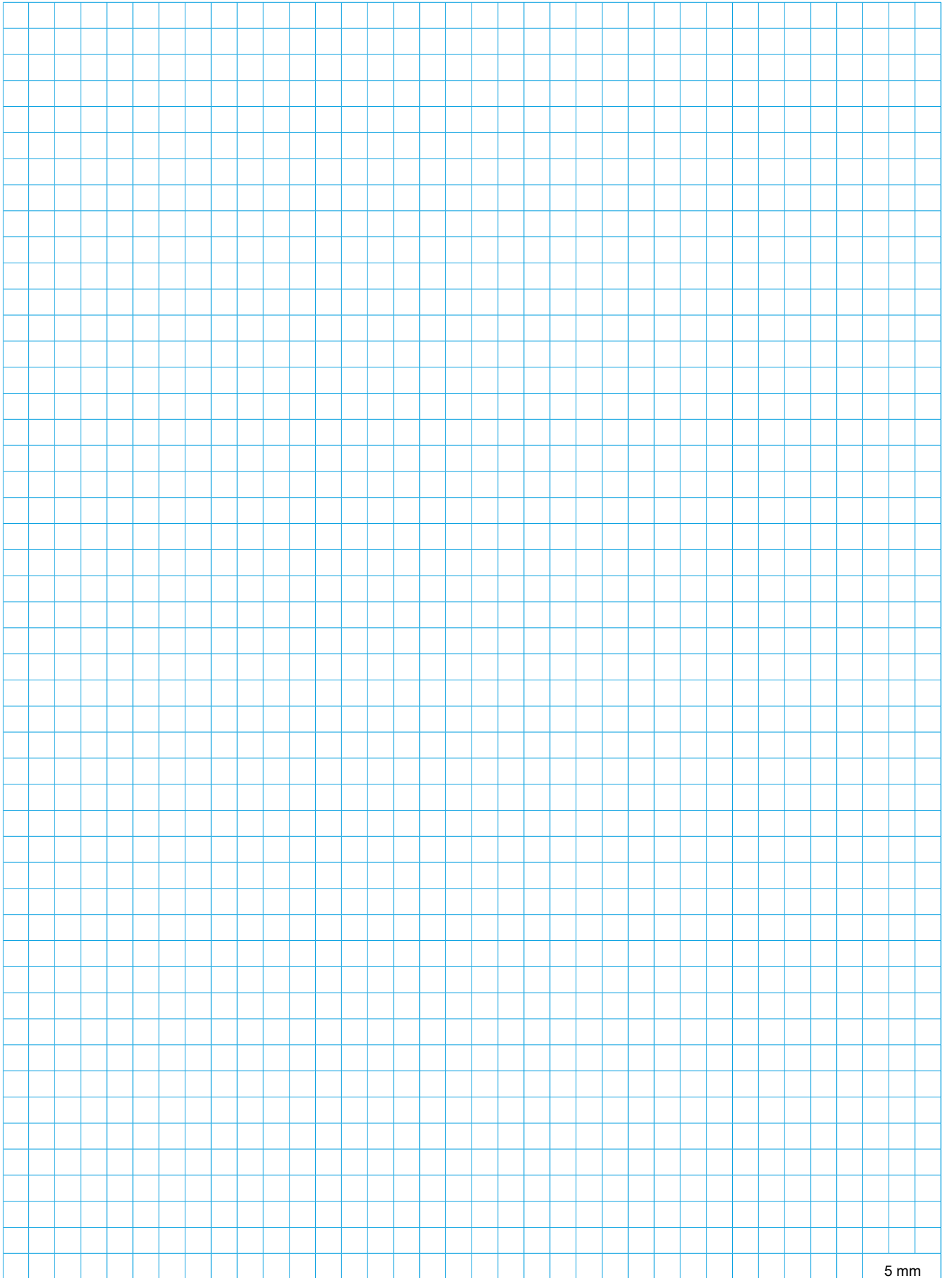

5 mm

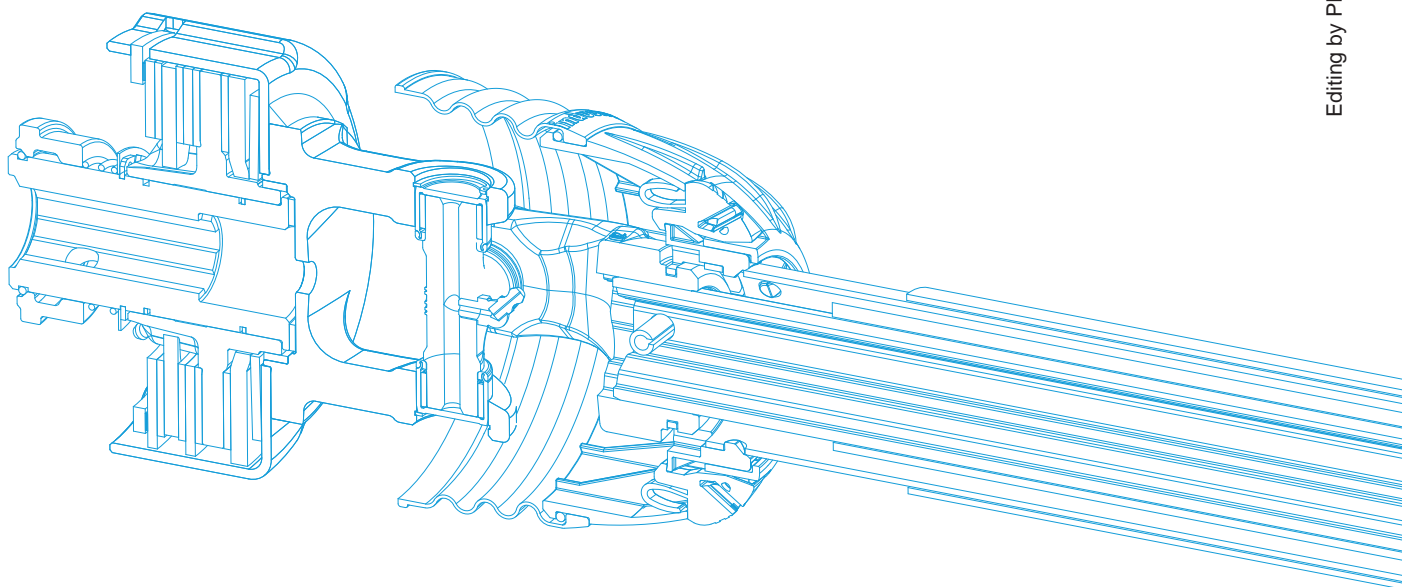

to partner with



comer industries

Comer Industries SpA

42046 Reggiolo (RE) - Italy - Via Magellano, 27 - Tel. +39 0522 974111 - Fax +39 0522 973249
www.comerindustries.com - info@comerindustries.com

Updated information about our sales network and product ranges is available at: www.comerindustries.com
Comer Industries shall have no liability for the completeness and accuracy of the information and cannot be held liable for any third-party claims or losses of any damages. The information represented in this catalogue can be revised at any time without notice.